

**2024 Illinois Statewide Technical  
Reference Manual for Energy Efficiency  
Version 12.0**

**Volume 2: Commercial and Industrial  
Measures**

**FINAL  
September 22, 2023**

**Effective:  
January 1, 2024**

[INTENTIONALLY LEFT BLANK]

**VOLUME 1: OVERVIEW AND USER GUIDE**

**4 VOLUME 2: COMMERCIAL AND INDUSTRIAL MEASURES ..... 10**

**4.1. Agricultural End Use..... 10**

4.1.1 ENGINE BLOCK TIMER FOR AGRICULTURAL EQUIPMENT ..... 10

4.1.2 HIGH VOLUME LOW SPEED FANS..... 13

4.1.3 HIGH SPEED FANS..... 17

4.1.4 LIVESTOCK WATERER ..... 21

4.1.5 FAN THERMOSTAT CONTROLLER..... 24

4.1.6 LOW PRESSURE SPRINKLER NOZZLES ..... 27

4.1.7 MILK PRE-COOLER..... 29

4.1.8 VSD MILK PUMP WITH PLATE COOLER HEAT EXCHANGER..... 32

4.1.9 SCROLL COMPRESSOR FOR DAIRY REFRIGERATION..... 35

4.1.10 DAIRY REFRIGERATION HEAT RECOVERY..... 38

4.1.11 COMMERCIAL LED GROW LIGHTS..... 42

4.1.12 SWINE HEAT PADS..... 47

4.1.13 IRRIGATION PUMP VFD..... 51

4.1.14 HIGH EFFICIENCY GRAIN DRYER..... 55

4.1.15 GRAIN DRYER TUNE-UP..... 62

4.1.16 GREENHOUSE BOILER TUNE-UP ..... 67

4.1.17 GREENHOUSE THERMAL CURTAINS ..... 70

4.1.18 INFRARED FILM FOR GREENHOUSE ..... 74

4.1.19 ENERGY STAR DAIRY WATER HEATER..... 78

4.1.20 COMMERCIAL ELECTRIC LAWN MOWER ..... 83

**4.2. Food Service Equipment End Use..... 87**

4.2.1 COMBINATION OVEN ..... 87

4.2.2 COMMERCIAL SOLID AND GLASS DOOR REFRIGERATORS & FREEZERS ..... 98

4.2.3 COMMERCIAL STEAM COOKER ..... 102

4.2.4 CONVEYOR OVEN ..... 112

4.2.5 ENERGY STAR CONVECTION OVEN..... 116

4.2.6 ENERGY STAR DISHWASHER ..... 125

4.2.7 ENERGY STAR FRYER..... 137

4.2.8 ENERGY STAR GRIDDLE ..... 145

4.2.9 ENERGY STAR HOT FOOD HOLDING CABINETS ..... 152

4.2.10 ICE MAKER ..... 155

4.2.11	HIGH EFFICIENCY PRE-RINSE SPRAY VALVE .....	159
4.2.12	INFRARED CHARBROILER .....	164
4.2.13	ROTISSERIE OVEN .....	166
4.2.14	INFRARED SALAMANDER BROILER .....	168
4.2.15	INFRARED UPRIGHT BROILER.....	170
4.2.16	KITCHEN DEMAND VENTILATION CONTROLS .....	172
4.2.17	PASTA COOKER .....	175
4.2.18	RACK OVEN - DOUBLE OVEN .....	177
4.2.19	ENERGY STAR ELECTRIC CONVECTION OVEN – REMOVED IN V11, CONSOLIDATED WITH 4.2.5 ENERGY STAR CONVECTION OVEN.....	180
4.2.20	EFFICIENT DIPPER WELLS .....	181
4.2.21	ON-DEMAND PACKAGE SEALERS – PROVISIONAL MEASURE .....	185
4.2.22	AUTOMATIC CONVEYOR BROILER.....	188
4.2.23	ELECTRIC DECK OVEN .....	192
4.2.24	GAS AND ELECTRIC PRESSURE FRYERS.....	196
4.2.25	EFFICIENT COOKTOPS .....	202
<b>4.3.</b>	<b>Hot Water .....</b>	<b>208</b>
4.3.1	WATER HEATER .....	208
4.3.2	LOW FLOW FAUCET AERATORS .....	222
4.3.3	LOW FLOW SHOWERHEADS .....	230
4.3.4	COMMERCIAL POOL COVERS.....	236
4.3.5	TANKLESS WATER HEATER – MEASURE COMBINED WITH 4.3.1 WATER HEATER IN VERSION 8 .....	240
4.3.6	OZONE LAUNDRY.....	241
4.3.7	MULTIFAMILY CENTRAL DOMESTIC HOT WATER PLANTS .....	249
4.3.8	CONTROLS FOR CENTRAL DOMESTIC HOT WATER.....	253
4.3.9	HEAT RECOVERY GREASE TRAP FILTER .....	258
4.3.10	DHW BOILER TUNE-UP .....	262
4.3.11	TUNNEL WASHERS.....	266
4.3.12	TANK INSULATION .....	270
4.3.13	TANKLESS WATER HEATER ARRAY .....	275
<b>4.4.</b>	<b>HVAC End Use .....</b>	<b>283</b>
4.4.1	AIR CONDITIONER TUNE-UP .....	288
4.4.2	SPACE HEATING BOILER TUNE-UP.....	291
4.4.3	PROCESS BOILER TUNE-UP .....	294



4.4.4	BOILER LOCKOUT/RESET CONTROLS.....	297
4.4.5	CONDENSING UNIT HEATERS .....	299
4.4.6	ELECTRIC CHILLER .....	301
4.4.7	ENERGY STAR AND CEE TIER 2 ROOM AIR CONDITIONER .....	310
4.4.8	GUEST ROOM ENERGY MANAGEMENT (PTAC & PTHP) .....	313
4.4.9	AIR AND WATER SOURCE HEAT PUMP SYSTEMS.....	320
4.4.10	HIGH EFFICIENCY BOILER.....	336
4.4.11	HIGH EFFICIENCY FURNACE.....	340
4.4.12	INFRARED HEATERS.....	347
4.4.13	PACKAGE TERMINAL AIR CONDITIONER (PTAC) AND PACKAGE TERMINAL HEAT PUMP (PTHP).....	350
4.4.14	PIPE INSULATION .....	358
4.4.15	SINGLE-PACKAGE AND SPLIT SYSTEM UNITARY AIR CONDITIONERS .....	376
4.4.16	STEAM TRAP REPLACEMENT OR REPAIR .....	389
4.4.17	VARIABLE SPEED DRIVES FOR HVAC PUMPS AND COOLING TOWER FANS .....	396
4.4.18	SMALL COMMERCIAL PROGRAMMABLE THERMOSTATS – RETIRED 12/31/2019. REPLACED WITH 4.4.48 SMALL COMMERCIAL THERMOSTATS.....	400
4.4.19	DEMAND CONTROLLED VENTILATION .....	401
4.4.20	HIGH TURNDOWN BURNER FOR SPACE HEATING BOILERS .....	406
4.4.21	LINKAGELESS BOILER CONTROLS FOR SPACE HEATING.....	409
4.4.22	OXYGEN TRIM CONTROLS FOR SPACE HEATING BOILERS .....	411
4.4.23	SHUT OFF DAMPER FOR SPACE HEATING BOILERS OR FURNACES .....	413
4.4.24	SMALL PIPE INSULATION .....	415
4.4.25	SMALL COMMERCIAL PROGRAMMABLE THERMOSTAT ADJUSTMENTS – RETIRED 12/31/2019.....	421
4.4.26	VARIABLE SPEED DRIVES FOR HVAC SUPPLY AND RETURN FANS .....	422
4.4.27	ENERGY RECOVERY VENTILATOR.....	428
4.4.28	STACK ECONOMIZER FOR BOILERS SERVING HVAC LOADS.....	433
4.4.29	STACK ECONOMIZER FOR BOILERS SERVING PROCESS LOADS.....	436
4.4.30	NOTCHED V BELTS FOR HVAC SYSTEMS .....	439
4.4.31	SMALL BUSINESS FURNACE AND ROOFTOP UNIT TUNE-UP .....	447
4.4.32	COMBINED HEAT AND POWER .....	450
4.4.33	INDUSTRIAL AIR CURTAIN .....	458
4.4.34	DESTRATIFICATION FAN .....	469
4.4.35	ECONOMIZER REPAIR AND OPTIMIZATION .....	476
4.4.36	MULTI-FAMILY SPACE HEATING STEAM BOILER AVERAGING CONTROLS.....	485

4.4.37	UNITARY HVAC CONDENSING FURNACE.....	487
4.4.38	COVERS AND GAP SEALERS FOR ROOM AIR CONDITIONERS.....	495
4.4.39	HIGH TEMPERATURE HEATING AND VENTILATION (HTHV) DIRECT FIRED HEATER .....	501
4.4.40	GAS HIGH EFFICIENCY SINGLE PACKAGE VERTICAL AIR CONDITIONER .....	507
4.4.41	ADVANCED ROOFTOP CONTROLS (ARC) .....	511
4.4.42	ADVANCED THERMOSTATS FOR SMALL COMMERCIAL – RETIRED 12/31/2019. REPLACED WITH 4.4.48 SMALL COMMERCIAL THERMOSTATS .....	520
4.4.43	PACKAGED RTU SEALING.....	521
4.4.44	COMMERCIAL GROUND SOURCE AND GROUND WATER SOURCE HEAT PUMP .....	526
4.4.45	ADSORBENT AIR CLEANING .....	556
4.4.46	SERVER ROOM TEMPERATURE SET BACK .....	561
4.4.47	AIR DEFLECTORS FOR UNIT VENTILATORS – PROVISIONAL MEASURE –REMOVED IN V12. ....	564
4.4.48	SMALL COMMERCIAL THERMOSTATS .....	565
4.4.49	BOILER CHEMICAL DESCALING.....	570
4.4.50	ELECTRIC CHILLERS WITH INTEGRATED VARIABLE SPEED DRIVES – REMOVED v12 .....	573
4.4.51	ADVANCED ROOFTOP CONTROLS WITH HIGH ROTOR POLE SWITCH RELUCTANCE MOTORS .....	574
4.4.52	HYDRONIC HEATING RADIATOR REPLACEMENT.....	585
4.4.53	HVAC SUPPLY, RETURN AND EXHAUST FANS – FAN ENERGY INDEX .....	590
4.4.54	PROCESS HEATING BOILER.....	596
4.4.55	COMMERCIAL GAS HEAT PUMP.....	600
4.4.56	COMMERCIAL DUCT SEALING.....	624
4.4.57	CONDENSATE RECOVERY SYSTEM .....	632
4.4.58	STEAM TRAP MONITORING SYSTEM .....	639
4.4.59	DUCTLESS HEAT PUMPS.....	646
4.4.60	VARIABLE REFRIGERANT FLOW HVAC SYSTEM.....	658
4.4.61	CHILLER CONDENSER WATER TEMPERATURE RESET .....	668
4.4.62	COOLING TOWER WATER SIDE ECONOMIZER .....	671
4.4.63	BOILER BLOWDOWN HEAT RECOVERY .....	673
4.4.64	STEAM VENT CONDENSERS.....	678
<b>4.5.</b>	<b>Lighting End Use.....</b>	<b>682</b>
4.5.1	COMMERCIAL ENERGY STAR COMPACT FLUORESCENT LAMP (CFL) – RETIRED 12/31/2018, REMOVED IN v8 .....	687
4.5.2	FLUORESCENT DELAMPING .....	688
4.5.3	HIGH PERFORMANCE AND REDUCED WATTAGE T8 FIXTURES AND LAMPS .....	692
4.5.4	LED BULBS AND FIXTURES.....	705

4.5.5	COMMERCIAL LED EXIT SIGNS .....	722
4.5.6	LED TRAFFIC AND PEDESTRIAN SIGNALS .....	726
4.5.7	LIGHTING POWER DENSITY .....	729
4.5.8	MISCELLANEOUS COMMERCIAL/INDUSTRIAL LIGHTING .....	747
4.5.9	MULTI-LEVEL LIGHTING SWITCH.....	751
4.5.10	LIGHTING CONTROLS .....	754
4.5.11	SOLAR LIGHT TUBES .....	761
4.5.12	T5 FIXTURES AND LAMPS .....	764
4.5.13	OCCUPANCY CONTROLLED BI-LEVEL LIGHTING FIXTURES.....	773
4.5.14	COMMERCIAL ENERGY STAR SPECIALTY COMPACT FLUORESCENT LAMP (CFL) – RETIRED 12/31/2018, REMOVED IN v8 777	
4.5.15	LED OPEN SIGN .....	778
4.5.16	LED STREETLIGHTING .....	782
4.5.17	EXTERIOR PHOTOCCELL REPAIR .....	786
4.5.18	ULTRA-EFFICIENT LED LIGHTING .....	788
<b>4.6.</b>	<b>Refrigeration End Use.....</b>	<b>794</b>
4.6.1	AUTOMATIC DOOR CLOSER FOR WALK-IN COOLERS AND FREEZERS.....	794
4.6.2	BEVERAGE AND SNACK MACHINE CONTROLS .....	796
4.6.3	DOOR HEATER CONTROLS FOR COOLER OR FREEZER.....	800
4.6.4	ELECTRONICALLY COMMUTATED MOTORS (ECM) FOR WALK-IN AND REACH-IN COOLERS / FREEZERS .....	803
4.6.5	ENERGY STAR REFRIGERATED BEVERAGE VENDING MACHINE .....	806
4.6.6	EVAPORATOR FAN CONTROL FOR ELECTRICALLY COMMUTATED MOTORS.....	809
4.6.7	STRIP CURTAIN FOR WALK-IN COOLERS AND FREEZERS .....	812
4.6.8	REFRIGERATION ECONOMIZERS .....	815
4.6.9	NIGHT COVERS FOR OPEN REFRIGERATED DISPLAY CASES .....	818
4.6.10	HIGH SPEED ROLLUP DOORS.....	821
4.6.11	Q-SYNC MOTORS FOR WALK-IN AND REACH-IN COOLERS/FREEZERS.....	826
4.6.12	VARIABLE SPEED DRIVE FOR CONDENSER FANS .....	833
4.6.13	ADD DOORS TO OPEN REFRIGERATED DISPLAY CASES.....	835
4.6.14	FLOATING HEAD PRESSURE CONTROL .....	840
<b>4.7.</b>	<b>Compressed Air.....</b>	<b>844</b>
4.7.1	VSD AIR COMPRESSOR.....	844
4.7.2	COMPRESSED AIR LOW PRESSURE DROP FILTERS .....	848
4.7.3	COMPRESSED AIR NO-LOSS CONDENSATE DRAINS .....	851

4.7.4	EFFICIENT COMPRESSED AIR NOZZLES .....	854
4.7.5	EFFICIENT REFRIGERATED COMPRESSED AIR DRYER.....	857
4.7.6	VORTEX TUBE THERMOSTAT - PROVISIONAL MEASURE – RETIRED 12/31/2023, REMOVED IN V12 .....	860
4.7.7	EFFICIENT DESICCANT COMPRESSED AIR DRYER.....	861
4.7.8	DESICCANT DRYER DEW POINT DEMAND CONTROLS.....	865
4.7.9	COMPRESSED AIR HEAT RECOVERY .....	869
4.7.10	COMPRESSED AIR STORAGE RECEIVER TANK .....	872
4.7.11	REDUCE COMPRESSED AIR SETPOINT.....	876
4.7.12	AODD PUMP CONTROLS.....	879
4.7.13	COMPRESSED AIR LEAK REPAIR .....	882
<b>4.8.</b>	<b>Miscellaneous End Use.....</b>	<b>885</b>
4.8.1	PUMP OPTIMIZATION .....	885
4.8.2	ROOF INSULATION FOR C&I FACILITIES .....	887
4.8.3	COMPUTER POWER MANAGEMENT SOFTWARE.....	893
4.8.4	MODULATING COMMERCIAL GAS CLOTHES DRYER.....	897
4.8.5	HIGH SPEED CLOTHES WASHER.....	899
4.8.6	ENERGY STAR COMPUTERS .....	903
4.8.7	ADVANCED POWER STRIP – TIER 1 COMMERCIAL .....	907
4.8.8	HIGH EFFICIENCY TRANSFORMER .....	910
4.8.9	HIGH FREQUENCY BATTERY CHARGERS .....	914
4.8.10	COMMERCIAL CLOTHES DRYER MOISTURE SENSOR .....	917
4.8.11	EFFICIENT THERMAL OXIDIZERS .....	921
4.8.12	SPRING-LOADED GARAGE DOOR HINGE.....	926
4.8.13	VARIABLE SPEED DRIVES FOR PROCESS FANS .....	931
4.8.14	LOW FLOW TOILETS AND URINALS .....	936
4.8.15	SMART IRRIGATION CONTROLS.....	939
4.8.16	COMMERCIAL WEATHER STRIPPING .....	943
4.8.17	SWITCH PERIPHERAL EQUIPMENT CONSOLIDATION .....	946
4.8.18	ENERGY STAR UNINTERRUPTIBLE POWER SUPPLY.....	950
4.8.19	ENERGY EFFICIENT RECTIFIER .....	954
4.8.20	ENERGY EFFICIENT HYDRAULIC OILS - PROVISIONAL MEASURE .....	957
4.8.21	ENERGY EFFICIENT GEAR LUBRICANTS - PROVISIONAL MEASURE.....	960
4.8.22	SMART SOCKETS.....	963
4.8.23	LITHIUM ION FORK TRUCK BATTERIES.....	967

4.8.24	BUILDING OPERATOR CERTIFICATION.....	972
4.8.25	WARM-MIX ASPHALT CHEMICAL ADDITIVES.....	976
4.8.26	ENERGY EFFICIENT HAND DRYERS.....	979
4.8.27	C&I AIR SEALING .....	983
4.8.28	HIGH SPEED OVERHEAD DOORS .....	990
4.8.29	DOCK DOOR SEALS AND SHELTER .....	1000
4.8.30	COMMERCIAL WALL INSULATION.....	1008

**VOLUME 3: RESIDENTIAL MEASURES**

**VOLUME 4: CROSS CUTTING MEASURES AND ATTACHMENTS**

## 4 Volume 2: Commercial and Industrial Measures

### 4.1. Agricultural End Use

#### 4.1.1 Engine Block Timer for Agricultural Equipment

##### DESCRIPTION

The measure is a plug-in timer that is activated below a specific outdoor temperature to control an engine block heater in agricultural equipment. Engine block heaters are typically used during cold weather to pre-warm an engine prior to start, for convenience, heaters are typically plugged in considerably longer than necessary to improve startup performance. A timer allows a user to preset the heater to come on for only the amount of time necessary to pre-warm the engine block, reducing unnecessary run time even if the baseline equipment has an engine block temperature sensor.

This measure was developed to be applicable to the following program types: RF. If applied to other program types, the measure savings should be verified.

##### DEFINITION OF EFFICIENT EQUIPMENT

The efficient measure is an engine block heater operated by an outdoor plug-in timer (15 amp or greater) that turns on the heater only when the outdoor temperature is below 25 °F.

##### DEFINITION OF BASELINE EQUIPMENT

The baseline scenario is an engine block heater that is manually plugged in by the farmer to facilitate equipment startup at a later time.

##### DEEMED LIFETIME OF EFFICIENT EQUIPMENT

The expected measure life is assumed to be 3 years.<sup>1</sup>

##### DEEMED MEASURE COST

The incremental cost per installed plug-in timer is \$10.19.<sup>2</sup>

##### COINCIDENCE FACTOR

Engine block timers only operate in the winter, so the summer peak demand savings is zero.

---

#### Algorithm

---

##### CALCULATION OF SAVINGS

##### ELECTRIC ENERGY SAVINGS

$$\Delta\text{kWh} = \text{ISR} * \text{Use Season} * \% \text{Days} * \text{HrSave/Day} * \text{kW}_{\text{heater}} - \text{ParaLd}$$

Where:

$$\begin{aligned} \text{ISR} &= \text{In Service Rate} \\ &= 78.39\%^3 \end{aligned}$$

---

<sup>1</sup> Equipment life is expected to be longer, but measure life is more conservative to account for possible attrition in use over time.

<sup>2</sup> Based on bulk pricing reported by EnSave, which administers the rebate in Vermont

<sup>3</sup> Efficiency Vermont (EVT) Technical Reference Manual (TRM), Measure Savings Algorithms and Cost Assumptions, March 16, 2015. Based on field study conducted by Efficiency Vermont on 352 sites in Vermont and Minnesota.

Use Season = The number of days in the use season in which the temperature drops below 25°F in the state of Illinois<sup>4</sup>

Climate Zone (City based upon)	Use Season
1 (Rockford)	79
2 (Chicago)	68
3 (Springfield)	53
4 (Belleville)	45
5 (Marion/Murphysboro)	27
<b>State-Wide Average</b>	<b>54</b>

%Days = Proportion of days timer is used with the Use Season  
= 84.23%<sup>5</sup>

HrSave/Day = Hours of savings per day when timer is used  
= 7.765 hours per day<sup>6</sup>

kW<sub>heater</sub> = Connected load of the engine block heater  
= 1.5 kW<sup>7</sup>

ParaLd = Parasitic load  
= 5.46 kWh<sup>8</sup>

**For example**, using the default assumptions on the installation of a timer on an engine block with a 1.5 kW heater:

$$\Delta\text{kWh} = 78.39\% * 54 \text{ days} * 84.23\% * 7.765 \text{ Hr/Day} * 1.5 \text{ kW} - 5.46 \text{ kWh}$$

$$= 409.8 \text{ kWh}$$

**SUMMER COINCIDENT PEAK DEMAND SAVINGS**

N/A

**FOSSIL FUEL SAVINGS**

N/A

**WATER IMPACT DESCRIPTIONS AND CALCULATION**

N/A

<sup>4</sup> The number of days in the use season in which the temperature drops below 25°F in the state of Illinois. The data is sourced as an average from TMYx weather data for five different weather zones within the state, see 'Ag Op Hours\_2023 – IL- Final.xlsx

<sup>5</sup> EVT TRM, March 16, 2015. Based on field study conducted by EVT on 352 sites in Vermont and Minnesota.

<sup>6</sup> Ibid. The hours per day saved is sourced as the difference between the baseline run hours per day without the timer, 10.66 hours, and the efficient run hours per day with the timer, 2.90 hours.

<sup>7</sup> Ibid. Based on an average sized engine block heater, which typically ranges in connected load from 0.20 kW and 2 kW, as sourced from Efficiency Vermont program data.

<sup>8</sup> Ibid.

**DEEMED O&M COST ADJUSTMENT CALCULATION**

N/A

**MEASURE CODE: CI-AGE-EBLT-V03-240101**

**REVIEW DEADLINE: 1/1/2029**



## 4.1.2 High Volume Low Speed Fans

### DESCRIPTION

The measure applies to horizontally mounted ceiling high volume low speed (HVLS) fans that are replacing multiple non HVLS fans that have reached the end of useful life in agricultural applications.

This measure was developed to be applicable to the following program types: TOS, RF. If applied to other program types, the measure savings should be verified.

### DEFINITION OF EFFICIENT EQUIPMENT

In order for this characterization to apply, the efficient equipment must be a fan with a diameter above 16 feet that meets program minimum efficiency requirements.

### DEFINITION OF BASELINE EQUIPMENT

As a retrofit measure, the actual existing conditions are taken as baseline. The number and wattage of the existing fans shall be used to define baseline energy consumption. As a time of sale measure, baseline is taken as the total operating wattage of conventional fans required to match the flow rate (CFM) rating of the efficient equipment.

### DEEMED LIFETIME OF EFFICIENT EQUIPMENT

The expected measure life is assumed to be 10 years.<sup>9</sup>

### DEEMED MEASURE COST

As a retrofit measure, the actual installation cost should be used for screening and reporting purposes.

For a time of sale measure, actual full installed costs may be used along with the following baseline cost assumptions:<sup>10</sup>

Diameter of Fan (feet)	Baseline Cost
16-17.9	\$1210
18-19.9	\$1460
20-23.9	\$1840
24 +	\$2090

If actual costs are unavailable for time of sale, the incremental measure costs are as follows:<sup>11</sup>

Diameter of Fan (feet)	Incremental Cost
16-17.9	\$4100
18-19.9	\$4130
20-23.9	\$4190
24 +	\$4230

<sup>9</sup> Average motor life is calculated by dividing the estimated motor life (35,000 hours) divided by the annual run hours, taken to be the unknown/other farm commodity type of 3,259 hours (see description of default run hours on following page); and rounded down to nearest whole year. Motor life source, U.S. Department of Energy Advanced Manufacturing Office, Motor Systems Tip Sheet #3.

<sup>10</sup> Baseline full installed costs linearly extrapolated using cost data from the Illinois ActOnEnergy TRM No. 2010-4. Midpoints were used to establish a single cost for each fan diameter category. Costs rounded up to the nearest \$10.

<sup>11</sup> Incremental costs linearly extrapolated using cost data from the Illinois ActOnEnergy TRM No. 2010-4. Midpoints were used to establish a single cost for each fan diameter category. Costs rounded up to the nearest \$10.

**LOADSHAPE**

Loadshape C34 - Industrial Motor

**COINCIDENCE FACTOR**

The measure has deemed kW savings therefore, a coincidence factor is not applied.

---



---

**Algorithm**

---



---

**CALCULATION OF SAVINGS**

**ELECTRIC ENERGY SAVINGS**

$$\Delta kWh = \frac{\sum(N_{base} * Watts_{base}) - \sum(N_{ee} * Watts_{ee})}{1000} * Hours$$

Where:

$N_{base}$  = Number of baseline (conventional) fans being replaced (of equivalent wattage)

= Actual (for Retrofit projects). For time of sale projects, the number of baseline fans should be set equivalent to the number of HVLS fans being installed.

$Watts_{base}$  = Operating demand (W) of baseline fan

= Actual (Retrofit). For time of sale projects refer to the time of sale HVLS connected load savings table below.

$N_{ee}$  = Number of efficient fans installed (of equivalent wattage)

= Actual

$Watts_{ee}$  = Operating demand (W) of efficient fan

= Actual (Retrofit). For time of sale projects refer to the Time of Sale HVLS connected load savings table below.

**Time of Sale HVLS Connected Load Savings<sup>12</sup>**

Diameter of Fan (feet)	Watts_base	Watts_ee
16-17.9	4497	761
18-19.9	5026	850
20-23.9	5555	940
24 +	6613	1119

Hours = Actual hours of operation. If unknown use the assumptions from the table below<sup>13</sup>

<sup>12</sup> KEMA 2009 Evaluation of IPL Energy Efficiency Programs, Appendix F, Group 1 Programs, Volume 2 (Table 17). Typically, the number of baseline conventional circulation fans the HVLS fan is off-setting is not a one for one replacement scenario. Due to their more efficient design, a single HVLS fan can move and displace as much air as multiple conventional circulation fans. The baseline wattage represents the equivalent quantity of baseline fans and their wattages to match that of a single HVLS fan.

<sup>13</sup> Based on NCEI/NCDC US Hourly Climate Normals data for Weather Stations in each Climate Zone, and weighted by 2010 US Census Data. The unknown/other commodity type is a weighted average of hog, poultry, and dairy facilities based on farm count as sourced from the U.S. 2017 Agriculture Census for Iowa. Dairy Farm Energy Management Guide, Southern California Edison February, 2004. The guide recommends controlling fans in order to provide maximum ventilation as necessary at 72°F and above due to heat stress concerns on cows at and above that temperature. The 67°F balance point was developed assuming a 5°F temperature band, assuming the interior temperature of the barn will be greater than that outside due to internal heat gains.

Facility Type	Annual Hours of Operation
Hog	3,458
Poultry	2,790
Dairy	2,455
Unknown/Other	3,133

Based on default assumptions above, deemed savings for replacing one fan would be:

Facility Type	Diameter of Fan (feet)	ΔkWh
Hog	16-17.9	12,919.1
	18-19.9	14,440.6
	20-23.9	15,958.7
	24 +	18,998.3
Poultry	16-17.9	10,423.4
	18-19.9	11,651.0
	20-23.9	12,875.9
	24 +	15,328.3
Dairy	16-17.9	9,171.9
	18-19.9	10,252.1
	20-23.9	11,329.8
	24 +	13,487.8
Unknown/Other	16-17.9	11,704.9
	18-19.9	13,083.4
	20-23.9	14,458.8
	24 +	17,212.7

**SUMMER COINCIDENT PEAK DEMAND SAVINGS**

$$\Delta kW = \frac{\sum(-N_{base} * Watts_{base}) - \sum(N_{ee} * Watts_{ee})}{1000} * CF$$

Where:

- CF = Summer Peak Coincidence Factor
- = 100%<sup>14</sup>

Based on default assumptions above, deemed savings would be:

Facility Type	Diameter of Fan (feet)	ΔkW
Hog	16-17.9	3.74
	18-19.9	4.18
	20-23.9	4.62
	24 +	5.49
Poultry	16-17.9	3.74
	18-19.9	4.18
	20-23.9	4.62
	24 +	5.49

<sup>14</sup> Industrial Ventilation CF from eQuest.

Facility Type	Diameter of Fan (feet)	$\Delta kW$
Dairy	16-17.9	3.74
	18-19.9	4.18
	20-23.9	4.62
	24 +	5.49
Unknown/Other	16-17.9	3.74
	18-19.9	4.18
	20-23.9	4.62
	24 +	5.49

**FOSSIL FUEL SAVINGS**

N/A

**WATER IMPACT DESCRIPTIONS AND CALCULATION**

N/A

**DEEMED O&M COST ADJUSTMENT CALCULATION**

N/A

**MEASURE CODE: CI-AGE-HVSF-V03-240101**

**REVIEW DEADLINE: 1/1/2028**

### 4.1.3 High Speed Fans

#### DESCRIPTION

The measure applies to high speed exhaust, ventilation and circulation fans that are replacing an existing unit that reached the end of its useful life in agricultural applications.

Agricultural circulation fans are fans located in barns to provide air movement that helps to keep animals cool. Circulation fan efficiency is expressed as CFM<sup>15</sup>/watt and is derived from the thrust efficiency ratio (TER) in pounds force per watt (lbf/W).

Agricultural ventilation fans provide ventilation air to keep animals cool. Fan efficiency is expressed as CFM/watt and is derived from the thrust efficiency ratio (TER) in pounds force per watt (lbf/kW).

This measure was developed to be applicable to the following program types: TOS. If applied to other program types, the measure savings should be verified.

#### DEFINITION OF EFFICIENT EQUIPMENT

In order for this characterization to apply, the efficient equipment must be certified by BESS Labs<sup>16</sup> with fan diameters above 12 inches that meet program minimum efficiency requirements.

Diameter of Fan (inches)	Circulation Fans IPL Minimum Efficiency (CFM/Watt)	Ventilation Fans IPL Minimum Efficiency (CFM/Watt) at (0.05 SP <sup>17</sup> )
12-23	10.7	10.1
24-35	11.5	13.5
36-47	19.0	17.4
48+	21.5	20.3

Efficient fans are assumed to be governed by thermostatic on/off controls.

#### DEFINITION OF BASELINE EQUIPMENT

In order for this characterization to apply, the baseline condition is assumed to be an existing fan that reached the end of its useful life.

#### DEEMED LIFETIME OF EFFICIENT EQUIPMENT

The expected measure life is assumed to be 10 years for Circulation Fans<sup>18</sup> and 7 years for Ventilation Fans<sup>19</sup>.

#### DEEMED MEASURE COST

Actual full installed costs may be used along with the following baseline cost assumptions:<sup>20</sup>

<sup>15</sup> Cubic Feet per Minute

<sup>16</sup> University of Illinois, Department of Agricultural and Biological Engineering. <http://bess.illinois.edu/>

<sup>17</sup> Static Pressure in units of inches of water

<sup>18</sup> Average motor life is calculated by dividing the estimated motor life (35,000 hours) divided by the annual run hours, taken to be the unknown/other farm commodity type of 3,259 hours (see description of default run hours on following page); and rounded down to nearest whole year. Motor life source, U.S. Department of Energy Advanced Manufacturing Office, Motor Systems Tip Sheet #3.

<sup>19</sup> Average motor life is calculated by dividing the estimated motor life (35,000 hours) divided by the annual run hours, taken to be the unknown/other farm commodity type of 4,800 hours (see description of default run hours on following page); and rounded down to nearest whole year. Motor life source, U.S. Department of Energy Advanced Manufacturing Office, Motor Systems Tip Sheet #3.

<sup>20</sup> Baseline full installed costs from Act on Energy Commercial Technical Reference Manual No. 2010-4. Cost for 12-23" diameter fans determined through extrapolation of costs for other fan sizes.

Diameter of Fan (inches)	Baseline Cost
12-23	\$375
24-35	\$450
36-47	\$525
48+	\$600

If actual cost not available, assume an incremental total installed cost of \$150.<sup>21</sup>

**LOADSHAPE**

Loadshape C34 - Industrial Motor

**COINCIDENCE FACTOR**

The measure has deemed kW savings therefore, a coincidence factor is not applied.

---

**Algorithm**

---

**CALCULATION OF SAVINGS**

**ELECTRIC ENERGY SAVINGS**

$$\Delta kWh = \frac{Watts\_base - Watts\_ee}{1000} * Hours * Nfans$$

Where:

Watts\_base<sup>22</sup> = Demand (W) of baseline fan

Diameter of Fan (inches)	Circulation Fan Watts_base	Ventilation Fan Watts_base
12-23	366	382
24-35	615	550
36-47	810	879
48+	1358	1353

Watts\_ee<sup>23</sup> = Demand (W) of efficient fan

Diameter of Fan (inches)	Circulation Fan Watts_ee	Ventilation Fan Watts_ee (0.05 SP)
12-23	298	304
24-35	440	383
36-47	529	565
48+	993	1041

Hours<sup>24</sup> = Actual hours of operation. TBD with new climate data

Facility Type	Circulation Fan Annual Hours of Operation	Ventilation Fan Annual EFLH
Hog	3,458	4,773

<sup>21</sup> Act on Energy Commercial Technical Reference Manual No. 2010-4.

<sup>22</sup> BESS fan database downloaded on 7/1/2015. Average watts from models below standard. AgCirculation Fans.xls

<sup>23</sup> BESS fan database downloaded on 7/1/2015. Average watts from models above standard. AgCirculation Fans.xls

<sup>24</sup> See "Ag Op Hours\_2023.xlsx" workbook for a complete description and derivation of default operating hours. EFLH based on US Hourly Climate Normals data for weighted statewide average. The unknown/other commodity type is a weighted average of hog, poultry, and dairy facilities based on farm count as sourced from the U.S. 2017 Agriculture Census for Iowa.

Facility Type	Circulation Fan Annual Hours of Operation	Ventilation Fan Annual EFLH
Poultry	2,790	5,298
Dairy	2,455	4,033
Unknown/Other	3,133	4,854

Nfans = Number of circulation fans  
 = Actual

Based on default assumptions above, deemed savings would be:

Facility Type	Diameter of Fan (feet)	Circulation Fan ΔkWh	Ventilation Fan ΔkWh
Hog	12-23	235.1	372.3
	24-35	605.2	797.1
	36-47	971.7	1,498.7
	48+	1,261.2	1,489.2
Poultry	12-23	189.7	413.2
	24-35	488.3	884.8
	36-47	784.0	1,663.6
	48+	1,018.4	1,653.0
Dairy	12-23	166.9	314.6
	24-35	429.6	673.5
	36-47	689.9	1,266.4
	48+	896.1	1,258.3
Unknown/Other	12-23	213.0	378.6
	24-35	548.3	810.6
	36-47	880.4	1,524.2
	48+	1143.6	1514.5

**SUMMER COINCIDENT PEAK DEMAND SAVINGS**

$$\Delta kW = \frac{Watts\_base - Watts\_ee}{1000} * CF * Nfans$$

Where:

CF = Summer Peak Coincidence Factor  
 = 100%<sup>25</sup>

Based on default assumptions above, deemed savings would be:

Facility Type	Diameter of Fan (feet)	Circulation Fan ΔkW	Ventilation Fan ΔkW
Hog	12-23	0.068	0.078
	24-35	0.175	0.167
	36-47	0.281	0.314
	48+	0.365	0.312
Poultry	12-23	0.068	0.078

<sup>25</sup> Industrial Ventilation CF from eQuest.

Facility Type	Diameter of Fan (feet)	Circulation Fan $\Delta kW$	Ventilation Fan $\Delta kW$
	24-35	0.175	0.167
	36-47	0.281	0.314
	48+	0.365	0.312
Dairy	12-23	0.068	0.078
	24-35	0.175	0.167
	36-47	0.281	0.314
	48+	0.365	0.312
Unknown/Other	12-23	0.068	0.078
	24-35	0.175	0.167
	36-47	0.281	0.314
	48+	0.365	0.312

**FOSSIL FUEL SAVINGS**

N/A

**WATER IMPACT DESCRIPTIONS AND CALCULATION**

N/A

**DEEMED O&M COST ADJUSTMENT CALCULATION**

N/A

**MEASURE CODE: CI-AGE-HSF-V03-240101**

**REVIEW DEADLINE: 1/1/2028**



#### 4.1.4 Livestock Waterer

##### DESCRIPTION

This measure applies to the replacement of electric open waterers with sinking or floating water heaters with equivalent herd size watering capacity of the old unit. Livestock waterers utilize electric heating elements and are used in cold climate locations in order to prevent water from freezing. Energy efficient livestock waterers, also called no or low energy livestock waterers, are closed and insulated watering containers that use lower wattage heating elements, thermostatically controlled, and water agitation (either in the form of air bubbles or floating balls), to prevent water from freezing, using less energy.

This measure was developed to be applicable to the following program types: RF, TOS. If applied to other program types, the measure savings should be verified.

##### DEFINITION OF EFFICIENT EQUIPMENT

In order for this characterization to apply, the efficient equipment is assumed to an electrically heated thermally insulated waterer with minimum 2 inches of insulation. A thermostat is required on unit with heating element greater than or equal to 250 watts.<sup>26</sup>

##### DEFINITION OF BASELINE EQUIPMENT

In order for this characterization to apply, the baseline equipment is assumed to be an electric open waterer with sinking or floating water heaters that have reached the end of useful life.

##### DEEMED LIFETIME OF EFFICIENT EQUIPMENT

The expected measure life is assumed to be 10 years.<sup>27</sup>

##### DEEMED MEASURE COST

For time of sale, the incremental cost is \$575<sup>28</sup>. For retrofit, use actual costs.

##### LOADSHAPE

Loadshape C04 - Non-Residential Electric Heating

##### COINCIDENCE FACTOR

Heated livestock waterers only operate in the winter in order to keep water from freezing so the summer peak coincident demand savings is zero.

---



---

#### Algorithm

---

##### CALCULATION OF SAVINGS

##### ELECTRIC ENERGY SAVINGS

$$\Delta kWh = \frac{(WattsBASE - WattsEE)}{1,000} * Hours$$

Where:

WattsBASE = Power consumption of baseline equipment. Actual, if known

---

<sup>26</sup> Act on Energy Commercial Technical Reference Manual No. 2010-4

<sup>27</sup> PA Consulting Group Inc. "State of Wisconsin Public Service Commission of Wisconsin Focus on Energy Evaluation Business Programs: Measure Life Study Final Report." August 25, 2009

<sup>28</sup> Internet research of leading distributors

- = If unknown, use 1,100 for RF, 500 for TOS<sup>29</sup>
- WattsEE = Power consumption of efficient equipment. Actual, if known
- = If unknown, use 250 for energy-efficient, 0 for energy free
- 1,000 = Kilowatt conversion factor
- Hours = Average annual run hours of heater. Actual if known.
- = If unknown, use the table below<sup>30</sup>

Climate Zone (City based upon)	Hours
1 (Rockford)	2,321
2 (Chicago)	2,103
3 (Springfield)	1,731
4 (Belleville)	1,362
5 (Marion/Murphysboro)	1,016
<b>State-Wide Average</b>	<b>1,707</b>

Based on default assumptions above, deemed savings would be:

Measure Type	Efficient Option	ΔkWh
Retrofit	Energy Efficient	1,451.0
	Energy Free	1,877.7
Time of Sale	Energy Efficient	426.8
	Energy Free	853.5

**SUMMER COINCIDENT PEAK DEMAND SAVINGS**

N/A

**FOSSIL FUEL SAVINGS**

N/A

**WATER IMPACT DESCRIPTIONS AND CALCULATION**

N/A

**DEEMED O&M COST ADJUSTMENT CALCULATION**

N/A

<sup>29</sup> EnSave, Energy Efficient Stock Waterers

<sup>30</sup> The number of days in the use season in which the temperature drops below 35°F in the state of Illinois. The data is sourced as an average from TMYx weather data for five different weather zones within the state, see 'Ag Op Hours\_2023 – IL- Final.xlsx

**MEASURE CODE: CI-AGE-LSW1-V04-240101**

**REVIEW DEADLINE: 1/1/2029**

### 4.1.5 Fan Thermostat Controller

#### DESCRIPTION

Incorporating a ventilation fan thermostat controller can reduce energy consumed where livestock is housed. Livestock ventilation fans reduce heat stress during the warmer months of the year.

For the purposes of this measure characterization, the installed ventilation fan thermostat controllers are temperature based on/off controls. While the complexity and intelligence of available controls can vary widely, where integrated controls can automate multiple modes and stages of ventilation, this measure assumes the control functionality is turning off the fan once the temperature falls to a certain point. It is recommended that other intelligent control technologies and strategies be handled through a custom approach, as these control installations require commissioning to optimize the functionality based on unique site and design considerations.

This measure was developed to be applicable to the following program types: TOS. If applied to other program types, the measure savings should be verified.

#### DEFINITION OF EFFICIENT EQUIPMENT

This measure applies to the incorporation of thermostatic controller for ventilation fans used in the livestock industry. To qualify, the ventilation fan must be used to modulate the temperature to reduce heat stress in a livestock facility.

#### DEFINITION OF BASELINE EQUIPMENT

The baseline for this measure is a non-thermostatically controlled livestock ventilation fan that operates constantly in their maximum capacity.

#### DEEMED LIFETIME OF EFFICIENT EQUIPMENT

The life expectancy of this measure is 15 years.<sup>31</sup>

#### DEEMED MEASURE COST

The incremental cost is estimated at \$50 per fan.<sup>32</sup>

#### LOADSHAPE

Loadshape C34 – Industrial Motor

#### COINCIDENCE FACTOR

The savings come from a reduction in nighttime operation, so a coincidence factor is not applicable for this measure.

---

#### Algorithm

---

#### CALCULATION OF ENERGY SAVINGS

The annual energy savings are generated by the fan being disabled at temperatures below 70°F. Typically the evening hours are cooler, and the ventilation fans are not required at these lower temperatures. It is assumed, prior to retrofit, that baseline ventilation fans are operating continuously from May 1st through October 31st, encapsulating the entire portion of the year in which hot temperatures exist and the need for livestock housing ventilation is prevalent. The efficient fan operation is derived from regional TMY3 data for the state of Illinois and represent, over

---

<sup>31</sup> Focus on Energy Evaluation Business Programs Measure Life Study: Final Report August 25, 2009, Public Service Commission of Wisconsin.

<sup>32</sup> The measure incremental cost is sourced from the 2023 Michigan Energy Measures Database (MEMD).

the same timeline that was used for the baseline, the number of hours in which the temperature is above 70°F. Electric Energy Savings

$$\Delta kWh = HP_{Fan} \times LF \times C_{ME} \times \Delta Hours \div Eff_{motor}$$

Where:

- HP<sub>Fan</sub> = Motor horsepower of the controlled fan  
= Actual; if unknown, default to 1 horsepower<sup>33</sup>
- LF = Fan load factor  
= 0.75
- CME = 0.746 kW to HP conversion factor
- ΔHours = Reduction in fan run hours as a result of the thermostat controller, dependent on location<sup>34</sup>

Zone	Hours <sub>Base</sub>	Hours <sub>Eff</sub>	ΔHours
Hog	6,307	4,773	1,534
Poultry	5,670	5,298	372
Dairy	4,829	4,033	795
Unknown/Other	5,937	4,854	1,083

- Eff<sub>motor</sub> = 82.5%<sup>35</sup>, motor efficiency

**For example**, using the default assumptions on a 1 horsepower fan thermostat controller for a single fan on a poultry farm:

$$\begin{aligned} \Delta kWh &= 1 \text{ HP} \times 0.75 \times 0.746 \times 372 \text{ hours} / 82.5\% \text{ efficiency} \\ &= 252.3 \text{ kWh} \end{aligned}$$

**SUMMER COINCIDENT PEAK DEMAND SAVINGS**

N/A – Assume fans will be in operation at maximum capacity during the coincident peak demand periods, resulting in zero potential demand savings during the hottest periods of the summer.

**FOSSIL FUEL SAVINGS**

N/A

**WATER AND OTHER NON-ENERGY IMPACT DESCRIPTIONS AND CALCULATION**

N/A

<sup>33</sup> The default fan horsepower is based on a review of single- and three-phase fans listed on BESS Labs performance tested exhaust fans between 36” and 47”. The Bioenvironmental and Structural Systems (BESS) Laboratory is a research and agriculture fan product-testing lab at the University of Illinois. For more detail on the derivation of fan horsepower from BESS Lab’s fan performance archive, please see “BESS Bin Data.xlsx”.

<sup>34</sup> National Centers for Environmental Information (NCEI) Annual Normals, from 2006 - 2020, calculated with a base temp of varying degrees for different livestock, see 'Ag Op Hours\_2023 - IL.xlsx for further details on fan staging temperatures.

<sup>35</sup> Table 1 with efficiency classes 60034-30 (2008), 4 Pole High Efficiency Motor, Technical note, IEC 600034-30 standard on efficiency classes for low voltage AC motors, TM)25 EN RevC 01-2-12, ABB.

**DEEMED O&M COST ADJUSTMENT CALCULATION**

N/A

**MEASURE CODE: CI-AGE-FNTC-V03-240101**

**REVIEW DEADLINE: 1/1/2029**

## 4.1.6 Low Pressure Sprinkler Nozzles

### DESCRIPTION

Incorporating low pressure sprinkler nozzles can decrease the energy and water consumed by reducing required water supply pressure to irrigate crop fields. Low pressure sprinkler nozzles can provide uniform water application by using various orifice applications and configurations while operating at a lower pressure compared to standard, impact driven sprinkler heads. Energy savings are achieved by the irrigation system operating at a lower water pressure while maintaining the same water distribution.

This measure was developed to be applicable to the following program types: TOS. If applied to other program types, the measure savings should be verified.

### DEFINITION OF EFFICIENT EQUIPMENT

Low Pressure Irrigation Nozzles operate at 35 psi or lower at rated/required flow. Annual Electric Savings obtained will be based on the number of nozzles replaced. To qualify the nozzles must operate for more than 500 hours per year and provide the equivalent flow at the reduced pressure. The maximum pump pressure must also be reduced accordingly.

### DEFINITION OF BASELINE EQUIPMENT

This measure applies to the replacement of high pressure irrigation nozzles that operate at 50 psi or greater at rated/required flow.

### DEEMED LIFETIME OF EFFICIENT EQUIPMENT

The life expectancy of this measure is 5 years.<sup>36</sup>

### DEEMED MEASURE COST

The incremental cost, including labor, is \$1.74 per nozzle.<sup>37</sup>

### LOADSHAPE

Loadshape C59 – Agriculture and Well Pumping

### COINCIDENCE FACTOR

Coincidence Factor = 0.793<sup>38</sup>

---

---

### Algorithm

---

---

### CALCULATION OF ENERGY SAVINGS

The annual energy savings and coincidental electric demand savings is based on PG&E research on irrigation well pumping systems and corrected based upon the type of crop, irrigated acres, and average acre-feet of water applied per acre.<sup>39</sup>

---

<sup>36</sup> Measure life is sourced from DEER 2008 for permanent, solid-set low pressure sprinkler nozzles.

<sup>37</sup> The incremental cost is sourced from SCE Workpaper, SCE13WP007, Low pressure Sprinkler Nozzles, January 2013.

<sup>38</sup> Iowa Energy Efficiency Statewide TRM, Version 3.0, effective January 1, 2019

<sup>39</sup> For additional detail on the derivation of Illinois-specific savings values and how the original source material was modified and normalized into single deemed values, please see the Illinois Workpaper for this measure, "Illinois\_Statewide\_TRM\_Workpaper\_Low Pressure Sprinkler Nozzles\_2019 4.1.7.docx".

**ELECTRIC ENERGY SAVINGS**

Annual kWh Savings = 4.06 kWh/yr/nozzle

**SUMMER COINCIDENT PEAK DEMAND SAVINGS**

Annual kW Savings = 0.0017 kW/yr/nozzle

**FOSSIL FUEL SAVINGS**

N/A

**WATER AND OTHER NON-ENERGY IMPACT DESCRIPTIONS AND CALCULATION**

N/A

**DEEMED O&M COST ADJUSTMENT CALCULATION**

N/A

**MEASURE CODE: CI-AGE-LPSN-V02-240101**

**REVIEW DEADLINE: 1/1/2029**



## 4.1.7 Milk Pre-Cooler

### DESCRIPTION

There is energy savings for adding a plate heat exchanger (pre-cooler) ahead of the milk storage tank. This addresses the electrical energy savings associated with the decreased milk cooling load. Installing a pre-cooler reduces milk temperature from 100°F to 55-70°F before it enters the bulk tank.

It is important to determine if the site has an adequate supply of water, as milk plate coolers require 1 to 2 times the amount of water as compared to processed milk, to be effective. However, sites leveraging plate coolers will repurpose the warm, discharged water, either for watering cows, wash-down, or other purposes on the farm. As there are indirect benefits associated with the warmer water,<sup>40</sup> and because it is typically repurposed, it is assumed that there are no negative water impacts for this measure. There are also no interactive domestic hot water savings attributable to the installation of a pre-cooler as the discharged water is typically not re-directed to the existing hot water heater.

This measure was developed to be applicable to the following program types: TOS. If applied to other program types, the measure savings should be verified.

### DEFINITION OF EFFICIENT EQUIPMENT

The installation of the heat exchanger to decrease the cooling requirement of the primary milk bulk tank refrigeration system. The heat exchanger fluid medium used for heat rejection is well or ground water as this produces the largest temperature differential for energy savings. For water requirements, the water supply system must have capacity to keep up with the existing farm water demands and additional demands of the pre-cooler. To minimize the volume of water used for pre-cooling, a solenoid valve should be installed on the water supply line to the pre-cooler and be actuated only when the milk pump is in operation. A bypass line around the solenoid valve or a time delay relay can also be used to provide additional cooling of the residual milk in the pre-cooler between pumping cycles. A storage tank will be necessary for used cooling water storage until it is re-used for watering cows, cleanup or another purpose on the farm.

### DEFINITION OF BASELINE EQUIPMENT

The baseline conditions assume that no previous pre-cooler heat exchanger was installed and the entire milk cooling load is on the milk bulk tank.

### DEEMED LIFETIME OF EFFICIENT EQUIPMENT

The life expectancy of this measure is 15 years.<sup>41</sup>

### DEEMED MEASURE COST

The average equipment cost of a plate cooler is \$2,950 with an installation cost of \$494, for a total incremental measure of \$3,444.<sup>42</sup>

### LOADSHAPE

Loadshape C58 – Farm Plate Cooler / Heat Recovery Unit

---

<sup>40</sup> It is less stressful (metabolically) for cows to drink warmed water, and research has shown that cows will drink more water if it is warmer, leading to increased milk production. “Massachusetts Farm Energy Best Management Practices for Dairy Farms”, United States Department of Agriculture (USDA), Natural Resource Conservation Service (NRCS), 2012.

<sup>41</sup> PA Consulting Group for the State of Wisconsin Public Service Commission, Focus on Energy Evaluation. Business Programs: Measure Life Study. Page 45 of pdf file. August 25, 2009.

<sup>42</sup> The equipment and labor costs are sourced from the PG&E Workpaper – Milk Pre Cooler (PGE3PAGR114), February 2013.

**COINCIDENCE FACTOR**

Coincidence factor of 0.16<sup>43</sup>

**Algorithm**

**CALCULATION OF ENERGY SAVINGS**

**ELECTRIC ENERGY SAVINGS**

Milk Pre-Cooler Heat Exchanger – Chiller Savings

$$\Delta kWh = \frac{\Delta T \times Lbs \text{ of Milk} \times Cows \times C_{p,m} \times Days}{EER \times 1,000}$$

Where:

- $\Delta T$  = Change in milk temperature attributable to the pre-cooler  
= 30°F<sup>44</sup>
- Lbs of Milk = The pounds of milk produced per day that needs to be cooled  
= 68 lbs of milk per cow<sup>45</sup>
- Cows = Number of milking cows per farm  
= Actual; if unknown use 101<sup>46</sup>
- $C_{p,m}$  = Specific heat of milk  
= 0.93 Btu/lb °F<sup>47</sup>
- Days = 365 days/yr
- EER = Efficiency of the existing compressor  
= 8.0 Btuh/watt<sup>48</sup>
- 1,000 = 1,000 Watts to kW conversion factor

**SUMMER COINCIDENT PEAK DEMAND SAVINGS**

$$\Delta kW = \frac{\Delta kWh}{Hours} \times CF$$

<sup>43</sup> Efficiency Vermont (EVT) Technical Reference Manual (TRM), Measure Savings Algorithms and Cost Assumptions, March 16, 2015

<sup>44</sup> The efficacy of a milk plate cooler is sourced from Sanford, Scott (University of Wisconsin–Madison). “Energy Efficiency for Dairy Enterprises.” Presentation to Agricultural and Life Sciences Program staff. December 2014. It was assumed that there is a 25°F of milk temperature difference for a single pass plate cooler and a 35°F of temperature difference for a double/multi-pass plate cooler. For the purposes of this measure, a straight average of 30°F between the two types was used. A plate cooler reduces the overall load on the refrigeration compressors and the revised  $\Delta T$  when accounting for a milk pre-cooler is 30°F less

<sup>45</sup> “Ag Heat Recovery Tank Supplemental Data.” WI Dairy Statistics tab shows USDA reported annual data from: U.S. Department of Agriculture. “Milk Production per Cow, Wisconsin.”

<sup>46</sup> The default value for the average number of milking cows per farm is sourced from the 2017 U.S. Census of Agriculture, Illinois State Summary Highlights, Full Report, Volume 1, Chapter 2, U.S. State Level. Average number of cows per farm = 93,341 cows / 924 farms.

<sup>47</sup> Specific heat of whole milk, Table 3: Unfrozen Composition Data, Initial Freezing Point, and Specific Heat of Foods, 2014 ASHRAE Handbook - Refrigeration. Page 19.5.

<sup>48</sup> Average efficiency of an existing compressor on a dairy farm, as sourced from, Massachusetts Farm Energy: Best Management Practices for Dairy Farms, USDA NRCS, 2012 (page 19).

Where:

Hours = 2920 hours<sup>49</sup>

CF = 0.16

**WATER AND OTHER NON-ENERGY IMPACT DESCRIPTIONS AND CALCULATION**

N/A

**DEEMED O&M COST ADJUSTMENT CALCULATION**

N/A

**MEASURE CODE: CI-AGE-MLKP-V02-240101**

**REVIEW DEADLINE: 1/1/2029**

---

<sup>49</sup> Raw milk for pasturing must be cooled with 4 hours. Assuming 2 milking per day. Dairy Farm Energy Management Guide: California, Ludington, Johnson, Kowalski, & Mage, Southern California Edison, 2004.

#### 4.1.8 VSD Milk Pump with Plate Cooler Heat Exchanger

##### **DESCRIPTION**

This technology incorporates adding a variable speed drive to a milk transfer pump. The VSD drive reduces the heat transferred to milk during pumping operation as well increases the amount of time the milk is in the free cooling heat exchanger. The VFD regulates the milk pump in order to increase the efficacy of the plate cooler heat exchanger by slowing the flow of milk. This results in a maximum heat transfer between the warm milk and the cold water used in the plate cooler.

Energy savings are realized by the reduced load on the primary milk cooling system. A milk transfer pump VSD is only effective if paired with a plate cooler.

This measure was developed to be applicable to the following program types: TOS. If applied to other program types, the measure savings should be verified.

##### **DEFINITION OF EFFICIENT EQUIPMENT**

Installation of a new variable speed drive (VSD) on a new or existing milk transfer process pump.

##### **DEFINITION OF BASELINE EQUIPMENT**

Must have a constant speed milk transfer process pump with no existing VSD controls. A plate cooling heat exchanger can already be a part of the system, or one installed in concert with the VSD.

##### **DEEMED LIFETIME OF EFFICIENT EQUIPMENT**

The life expectancy of this measure is 15 years.<sup>50</sup>

##### **DEEMED MEASURE COST**

The average equipment cost of a milk vacuum pump variable speed drive is \$3,871 with an installation cost of \$1,177, for a total incremental measure of \$5,048.<sup>51</sup>

##### **LOADSHAPE**

Loadshape C57 – Milk Pump

##### **COINCIDENCE FACTOR**

There are no summer coincident peak savings for VFD dairy milk pumps. Through research of refrigeration compressor power demands, no substantial evidence has arisen that any notable kW demand reduction is possible in relation to using a VFD with a milk pre-cooler to pre-cool milk that would otherwise need to be chilled through mechanical refrigeration means.

---

<sup>50</sup> Focus on Energy Evaluation Business Programs Measure Life Study: Final Report August 25, 2009, Public Service Commission of Wisconsin.

<sup>51</sup> The equipment and labor costs are sourced from the PG&E Workpaper – Milk Vacuum Pump VSD, Dairy Farm Equipment (PGE3PAGR116), February 2013.

**Algorithm**

**CALCULATION OF ENERGY SAVINGS**

**ELECTRIC ENERGY SAVINGS**

$$\Delta kWh = \frac{1}{EER} \times C_{p,m} \times \Delta T \times \text{Lbs of Milk} \times \text{Cows} \times \text{Days} / 1,000$$

Where:

- EER = Efficiency of the existing compressor  
= 8.0 Btu/watt<sup>52</sup>
- C<sub>p,m</sub> = Specific heat of milk  
= 0.93 Btu/lb °F<sup>53</sup>
- ΔT = Change in milk temperature as a result of the milk transfer pump VSD. This value is the additional benefits of a VSD on the milk pump over a standard plate cooler  
= 11.7 °F<sup>54</sup>
- Lbs of Milk = The pounds of milk produced per day that needs to be cooled  
= 68 lbs of milk per cow<sup>55</sup>
- Cows = Number of milking cows per farm  
= Actual, if unknown use 101<sup>56</sup>
- Days = 365.25 days of milking per year
- 1,000 = Watts to kW conversion factor

**For example**, using the default assumptions, the average kWh savings resulting from the installation of a milk transfer pump VSD is:

$$\Delta kWh = \frac{1}{8.0 \text{ Btu/Watt}} \times 0.93 \times 11.7^\circ F \times 68 \frac{\text{lbs}}{\text{milk/cow}} \times 101 \text{ cows} \times 365 \frac{\text{days}}{\text{yr}} / 1,000$$

$$= 3,410 \text{ kWh}$$

**SUMMER COINCIDENT PEAK DEMAND SAVINGS**

N/A

<sup>52</sup> Average efficiency of an existing compressor on a dairy farm, as sourced from, Massachusetts Farm Energy: Best Management Practices for Dairy Farms, USDA NRCS, 2012 (page 19)

<sup>53</sup> Specific heat of whole milk, Table 3: Unfrozen Composition Data, Initial Freezing Point, and Specific Heat of Foods, 2014 ASHRAE Handbook - Refrigeration. Page 19.5.

<sup>54</sup> Sanford, Scott (University of Wisconsin–Madison). “Well Water Precoolers.” Publication A37843. October 2003. It was determined that a plate cooler alone can reduce milk temperature to 68 °F and a plate cooler paired with a milk transfer pump VSD can reduce milk temperature to 56.3 °F. The additional benefits of the milk transfer pump VSD over the plate cooler is 11.7 °F.

<sup>55</sup> “Ag Heat Recovery Tank Supplemental Data.” WI Dairy Statistics tab shows USDA reported annual data from: U.S. Department of Agriculture. “Milk Production per Cow, Wisconsin.”

<sup>56</sup> The default value for the average number of milking cows per farm is sourced from the 2017 U.S. Census of Agriculture, Illinois State Summary Highlights, Full Report, Volume 1, Chapter 2, U.S. State Level. Average number of cows per farm = 93,341 cows / 924 farms.

**FOSSIL FUEL SAVINGS**

N/A

**WATER AND OTHER NON-ENERGY IMPACT DESCRIPTIONS AND CALCULATION**

N/A

**DEEMED O&M COST ADJUSTMENT CALCULATION**

N/A

**MEASURE CODE: CI-AGE-VSDM-V02-240101**

**REVIEW DEADLINE: 1/1/2029**

## 4.1.9 Scroll Compressor for Dairy Refrigeration

### DESCRIPTION

Incorporating a more efficient compressor for process milk refrigeration can decrease the energy consumed at dairy farms. This measure is for the installation of a scroll compressor to replace an existing reciprocating compressor on a milk refrigeration bulk tank. The milk refrigeration system is used to cool milk for preservation and packaging. Milk is extracted from the cow at 98°F and cooled to 38°F, resulting in a substantial load on the milk cooling equipment, which is typically the largest energy use on a dairy farm. Scroll compressors can provide increased refrigeration efficiencies with improved EERs over baseline reciprocating compressors.

The energy savings for this measure is dependent on if the site is utilizing pre-cooling equipment such as a milk plate cooler. Plate coolers can reduce the incoming temperature of the milk into the refrigeration bulk tank, reducing the overall load on the compressor and the potential savings benefits.

This measure was developed to be applicable to the following program types: TOS. If applied to other program types, the measure savings should be verified.

### DEFINITION OF EFFICIENT EQUIPMENT

For an efficient scroll compressor with or without a plate cooler heat exchanger, the proposed compressor must be rated at 10.6 EER or greater on a process milk refrigeration system. The calculation assumes the cooling capacity of the compressor remains the same.

### DEFINITION OF BASELINE EQUIPMENT

The baseline condition is assumed to be a reciprocating compressor.

### DEEMED LIFETIME OF EFFICIENT EQUIPMENT

The expected life of this measure is 15 years.<sup>57</sup>

### DEEMED MEASURE COST

The incremental cost is \$400 per compressor.<sup>58</sup>

### LOADSHAPE

Loadshape C56 – Dairy Farm Combined End Use

### COINCIDENCE FACTOR

Coincidence factor of 0.34<sup>59</sup>

---

<sup>57</sup> Focus on Energy Evaluation Business Programs Measure Life Study: Final Report August 25, 2009, Public Service Commission of Wisconsin.

<sup>58</sup> The incremental cost is sourced from Sanford, Scott (University of Wisconsin-Madison). "Energy Efficiency for Dairy Enterprises." Presentation to Agricultural and Life Sciences Program Staff. December 2014.

<sup>59</sup> Efficiency Vermont (EVT) Technical Reference Manual (TRM), Measure Savings Algorithms and Cost Assumptions, March 16, 2015

**Algorithm**

**CALCULATION OF ENERGY SAVINGS**

**ELECTRIC ENERGY SAVINGS**

$$\Delta kWh = \frac{\left( \frac{1}{EER_{base}} - \frac{1}{EER_{eff}} \right) \times Process\ Load}{1,000}$$

Where:

- $EER_{base}$  = Efficiency of the existing compressor  
= 8.4 Btu/watt<sup>60</sup>
- $EER_{eff}$  = Efficiency of the installed, scroll compressor  
= 10.6 Btu/watt<sup>61</sup>
- Process Load =  $C_{p,Milk} \times \Delta T \times Lbs\ of\ Milk \times Cows \times Days$

Where:

- $C_{p,Milk}$  = Specific heat of milk  
= 0.93 Btu/lb °F<sup>62</sup>
- $\Delta T$  = Change in milk temperature as result of the primary cooling system  
= 60°F without a milk plate cooler<sup>63</sup>  
= 30°F with a milk plate cooler<sup>64</sup>
- Lbs of Milk = The pounds of milk produced per day that needs to be cooled  
= 68 lbs of milk per cow<sup>65</sup>
- Cows = Number of milking cows per farm  
= Actual; if unknown use 101<sup>66</sup>
- Days = 365 days per year

<sup>60</sup> Average efficiency of a reciprocating compressor, as sourced from Wisconsin Focus on Energy TRM – Plate Heat Exchanger and Well Water Pre-Cooler, 2017

<sup>61</sup> Average efficiency of a scroll compressor, as sourced from Massachusetts Farm Energy: Best Management Practices for Dairy Farms, USDA NRCS, 2012 (page 33)

<sup>62</sup> Specific heat of whole milk, Table 3: Unfrozen Composition Data, Initial Freezing Point, and Specific Heat of Foods, 2014 ASHRAE Handbook - Refrigeration. Page 19.5.

<sup>63</sup> Safe Handling of Milk & Dairy Products. March 8th, 2017 and Sanford, Scott (University of Wisconsin–Madison). “Well Water Precoolers.” Publication A37843. October 2003. The temperature of the milk exiting the cow is considered to be 98°F and the final, cooled temperature of the milk is assumed to be 38°F.

<sup>64</sup> The efficacy of a milk plate cooler is sourced from Sanford, Scott (University of Wisconsin–Madison). “Energy Efficiency for Dairy Enterprises.” Presentation to Agricultural and Life Sciences Program staff. December 2014. It was assumed that there is a 25°F of milk temperature difference for a single pass plate cooler and a 35°F of temperature difference for a double/multi-pass plate cooler. For the purposes of this measure, a straight average of 30°F between the two types was used. A plate cooler reduces the overall load on the refrigeration compressors and the revised  $\Delta T$  when accounting for a milk pre-cooler is 30°F less.

<sup>65</sup> “Ag Heat Recovery Tank Supplemental Data.” WI Dairy Statistics tab shows USDA reported annual data from: U.S. Department of Agriculture. “Milk Production per Cow, Wisconsin.”

<sup>66</sup> The default value for the average number of milking cows per farm is sourced from the 2017 U.S. Census of Agriculture, Illinois State Summary Highlights, Full Report, Volume 1, Chapter 2, U.S. State Level. Average number of cows per farm = 93,341 cows / 924 farms.



1,000 = 1000 watts to kW conversion factor

**For example**, using the default assumptions, average kWh savings of an installed scroll compressor on the milk refrigeration bulk tank with a dairy using an existing plate cooler is:

$$\Delta kWh = \frac{\left(\frac{1}{8.4 \text{ EER}} - \frac{1}{10.6 \text{ EER}}\right) \times \frac{0.93 \text{ Btu}}{\text{lb of Milk}} \times (98^\circ\text{F} - 30^\circ\text{F} - 38^\circ\text{F}) \times 68 \frac{\text{lbs milk}}{\text{cow}} \times 101 \text{ cows} \times 365 \text{ Days}}{1000 \text{ Watts/kW}}$$

$\Delta kWh = 1,728 \text{ kWh}$

**SUMMER COINCIDENT PEAK DEMAND SAVINGS**

$$\Delta kW = \frac{\Delta kWh}{\text{Hours}} \times CF$$

Where:

Hours = 2,920 hours<sup>67</sup>

CF = 0.34

**For example**, using the default assumptions, average coincident peak demand savings of an installed scroll compressor on the milk refrigeration bulk tank with a dairy using an existing plate cooler is:

$$\Delta kW = \frac{1,728 \text{ kWh}}{2,920 \text{ Hours}} \times 0.34$$

$\Delta kW = 0.201 \text{ kW}$

**FOSSIL FUEL SAVINGS**

N/A

**WATER AND OTHER NON-ENERGY IMPACT DESCRIPTIONS AND CALCULATION**

N/A

**DEEMED O&M COST ADJUSTMENT CALCULATION**

**MEASURE CODE: CI-AGE-SCRC-V02-240101**

**REVIEW DEADLINE: 1/1/2029**

<sup>67</sup> Raw milk for pasturing must be cooled with 4 hours. Assuming 2 milking per day. Dairy Farm Energy Management Guide: California, Ludington, Johnson, Kowalski, & Mage, Southern California Edison, 2004.

## 4.1.10 Dairy Refrigeration Heat Recovery

### DESCRIPTION

A refrigeration heat recovery (RHR) unit captures waste heat from the refrigeration system and uses a heat exchange to transfer some of that heat into incoming well water. That captured waste heat is used to pre-heat ground water before it enters the primary water heater and brought to the desired final temperature needed for cleaning farm equipment. The hot compressed refrigerant is diverted and flows through the heat exchanger, attached to a secondary water tank, on its way to the condenser unit. The heat from the refrigerant is transferred through the tank into the water. Thermal buoyancy causes the warmest water to rise to the top of the tank. When hot water is used, water flows from the RHR tank into the water heater, and well water flows into the heat recovery tank. These units can assist in reducing water heating energy use by approximately 50%.<sup>68</sup>

It is important to note that if a dairy farm installs an RHR unit and a milk plate cooler, (with or without the use of milk pump VFD control), the plate cooler will impact the savings potential of the RHR unit. The use of a plate cooler will reduce the total milk mechanical refrigeration load. Due to this refrigeration load reduction, the amount of heat rejection possible to the RHR system is diminished.

This measure was developed to be applicable to the following program types: TOS. If applied to other program types, the measure savings should be verified.

### DEFINITION OF EFFICIENT EQUIPMENT

The efficient condition is farm refrigeration equipment where an RHR tank is installed and captures waste refrigerant heat from the refrigeration system compressor and transfers that waste into an RHR tank, supplied with cool ground water, through a heat exchanger before continuing through the refrigeration system condensing unit. The newly preheated water in the RHR tank is supplied into the farm's main water heater unit, which will have a smaller temperature differential to overcome, compared to a direct ground water heater feed.

### DEFINITION OF BASELINE EQUIPMENT

The baseline condition is an existing dairy farm with refrigeration equipment and a water heater unit without the use of an RHR unit to feed preheated water to the water heater. Water heater is fed directly with ground water.

### DEEMED LIFETIME OF EFFICIENT EQUIPMENT

The expected useful life is 15 years.<sup>69</sup>

### DEEMED MEASURE COST

The incremental cost is \$4,353.<sup>70</sup>

### LOADSHAPE

Loadshape C58 – Farm Plate Cooler / Heat Recovery Unit

### COINCIDENCE FACTOR

There are no summer coincident peak savings for RHR units. It is assumed that electric water heaters have a single element and will still be used to heat water up to full temperature, and that the kW rating is unchanged when an RHR unit is added in the water heating loop (resulting in no demand reduction).

---

<sup>68</sup> U.S. Department of Agriculture, Natural Resources Conservation Service. "Energy Self-Assessment: Refrigeration Heat Recovery." Accessed April 27<sup>th</sup>, 2023.

<sup>69</sup> PA Consulting Group Inc. "State of Wisconsin Public Service Commission of Wisconsin Focus on Energy Evaluation Business Programs: Measure Life Study Final Report." August 25, 2009.

<sup>70</sup> The incremental cost is sourced from Efficiency Vermont custom project data based on actual equipment installs between 2010 and 2017.

**Algorithm**

**CALCULATION OF ENERGY SAVINGS**

**ELECTRIC ENERGY SAVINGS**

$$\Delta kWh = Btu_{Recovered} * Days * \left( \frac{1}{EF_{elec}} \right) / 3,412$$

Where:

$$Btu_{Recovered} = Btu_{Milk\ Potential} \text{ or } Btu_{RHR\ Storage} \text{ (lesser of the two)}$$

Where:

$$Btu_{Milk\ Potential} = Lbs\ of\ Milk * Cows * C_{P,Milk} * \Delta T_{Milk} * SF$$

and

$$Btu_{Storage} = Hot\ Water * C_{P,Water} * P_{Water} * \Delta T_{Water}$$

- Days = Number of milking days per year  
= 365.25 days<sup>71</sup>
- 3,412 = Btu to kWh electric conversion factor
- EF<sub>elec</sub> = Energy factor for a standard electric water heater  
= 90%<sup>72</sup>
- Lbs of Milk = The pounds of milk produced per day per cow that needs to be cooled  
= 68 lbs of milk per cow<sup>73</sup>
- Cows = Number of milking cows per farm  
= Actual, if unknown use 101<sup>74</sup>
- C<sub>P,Milk</sub> = Specific heat of milk  
= 0.93 Btu/(lb-°F)<sup>75</sup>
- ΔT<sub>Milk</sub> = Change in milk temperature  
= °F<sub>IN</sub> - °F<sub>FINAL</sub>  
°F<sub>IN</sub> = Temperature of milk being supplied that needs to be cooled

<sup>71</sup> Wisconsin Milk Marketing Board. "Did You Know? Website: Milking Every Day." Accessed December 21, 2015

<sup>72</sup> Talbot, Jacob (American Council for an Energy-Efficient Economy). ACEEE Report A121: Market Transformation Efforts for Water Heating Efficiency. January 2012.

<sup>73</sup> "Ag Heat Recovery Tank Supplemental Data." WI Dairy Statistics tab shows USDA reported annual data from: U.S. Department of Agriculture. "Milk Production per Cow, Wisconsin."

<sup>74</sup> The default value for the average number of milking cows per farm is sourced from the 2017 U.S. Census of Agriculture, Illinois State Summary Highlights, Full Report, Volume 1, Chapter 2, U.S. State Level. Average number of cows per farm = 93,341 cows / 924 farms.

<sup>75</sup> Specific heat of whole milk, Table 3: Unfrozen Composition Data, Initial Freezing Point, and Specific Heat of Foods, 2014 ASHRAE Handbook - Refrigeration. Page 19.5.

= 98°F if no pre-cooler is used in operation; 68°F if a milk pre-cooler is used;<sup>76</sup>  
 56.3°F if a milk pre-cooler and VFD milk transfer pump are used.<sup>77</sup>

$^{\circ}\text{F}_{\text{FINAL}}$  = Final stored temperature of cooled milk  
 = 38°F

SF = Savings factor for the percentage of energy able to be captured from the milk cooling process  
 = 55%<sup>78</sup>

Hot Water = Amount of hot water per day in gallons that the site uses for washing and cleaning purposes  
 = 131.7 gallons<sup>79</sup>

$C_{p,\text{Water}}$  = Specific heat of water  
 = 1 Btu/lb-°F

$P_{\text{Water}}$  = Density of water  
 = 8.34 lbs/gallon

$\Delta T_{\text{Water}}$  = Temperature difference =  $\text{Temp}_{\text{warm water}} - \text{Temp}_{\text{cold water}}$

$\text{Temp}_{\text{warm water}}$  = 120°F, expected temperature a refrigeration heat recovery unit can pre-heat well water up to.

$\text{Temp}_{\text{cold water}}$  = 52.3°F, average well water temperature

**SUMMER COINCIDENT PEAK DEMAND SAVINGS**

None

**FOSSIL FUEL SAVINGS**

$$\Delta Therms = Btu_{\text{Recovered}} * Days * \left( \frac{1}{EF_{\text{gas}}} \right) / 100,000$$

Where:

<sup>76</sup> The efficacy of a milk plate cooler is sourced from Sanford, Scott (University of Wisconsin–Madison). “Energy Efficiency for Dairy Enterprises.” Presentation to Agricultural and Life Sciences Program staff. December 2014. It was assumed that there is a 25°F of milk temperature difference for a single pass plate cooler and a 35°F of temperature difference for a double/multi-pass plate cooler. For the purposes of this measure, a straight average of 30°F between the two types was used. A plate cooler reduces the overall load on the refrigeration compressors and the revised  $\Delta T$  when accounting for a milk pre-cooler is 30°F less.

<sup>77</sup> Sanford, Scott (University of Wisconsin–Madison). “Well Water Precoolers.” Publication A37843. October 2003

<sup>78</sup> DeLaval. “Dairy Farm Energy Efficiency.” April 20, 2011. DeLaval estimates the heat recovery potential to be between 20 and 60%. Based on engineering judgement and further corroboration from the Wisconsin Focus on Energy TRM, opted to default to a 55% savings factor.

<sup>79</sup> The hot water use per day is based on the average hot water requirements per wash cycle multiplied by the number of wash cycles per day. The average amount of hot water used per wash cycle, 47.9 gallons, is sourced from the National Resource Conservation Service for Wash Water Requirements for Milking Systems, a calculator developed by University of Wisconsin, August 2005, Milking Center Waste Volume, v12,05, The number of wash cycles per day account for the hot water rinse cycles that are used to flush and clean the milk lines before and after milking. As sourced from the Regional Technical Forum (RTF) as part of the Northwest Power & Conservation Council, Deemed Measures List; Agricultural: Variable Frequency Drives-Dairy, FY2012, v1.2. Pre- and post-power meter data for five sites were used to establish RTF energy savings and the raw data used to generate load profiles showed, on average, two milkings per day. As there will be one more wash cycle than milking, the default average wash cycles per day is three.

100,000 =Btu to therms natural gas conversion factor  
EF<sub>gas</sub> = Energy factor for a standard natural gas water heater  
= 59%

Other variables remain consistent with 'Electric Energy Savings' calculation method.

**WATER AND OTHER NON-ENERGY IMPACT DESCRIPTIONS AND CALCULATION**

N/A

**DEEMED O&M COST ADJUSTMENT CALCULATION**

N/A

**MEASURE CODE: CI-AGE-DRHR-V02-240101**

**REVIEW DEADLINE: 1/1/2029**

#### 4.1.11 Commercial LED Grow Lights

##### **DESCRIPTION**

LED lamp technology offers reduced energy and maintenance costs when compared with conventional light sources. LED technology has a significantly longer useful life lasting 30,000 hours or more and significantly reduces maintenance costs. The savings and costs for this measure are evaluated with the replacement of HID grow lights with LED fixtures. LED lamps offer a more robust lighting source, longer lifetime, and greater electrical efficiency than conventional supplemental grow lights.

This measure is designed for other interior horticultural applications that use artificial light stimulation in an indoor conditioned space.

This measure was developed to be applicable to the following program types: TOS. If applied to other program types, the measure savings should be verified.

##### **DEFINITION OF EFFICIENT EQUIPMENT**

LED fixtures must have a reduced wattage, be listed on the Design Lights Consortium (DLC) qualified products list,<sup>80</sup> be UL Listed, have a power factor (PF)  $\geq 0.90$ , a photosynthetic photon efficacy (PPE) of no less than 1.9 micromoles per joule, a minimum rated lifetime of 50,000 hours, and a minimum warranty of 5 years. If DLC PPE requirements for LED grow lighting exceeds the current requirements, the new PPE will become the efficient equipment standard.

##### **DEFINITION OF BASELINE EQUIPMENT**

The baseline equipment is the industry established grow light based on the horticultural application, as detailed in the table below. HID fixtures are assumed for flowering and vegetative crops. T5 high-output fixtures are assumed for seedling and microgreen crops.

---

<sup>80</sup> Design Light Consortium – Horticultural Lighting, Testing and Reporting Requirements for LED-Based Horticultural Lighting, version 2.1, effective September 1, 2021. To date, all horticultural lamps certified by the DLC specification are LEDs.

Crop Type	Baseline Technology Type	Baseline PPE ( $\mu\text{mol}/\text{J}$ ) <sup>81</sup>	Baseline Fixture Wattage <sup>82</sup>
Flowering Crops (Tomatoes and Peppers)	High Pressure Sodium	1.7	1,100 W
Vegetative Growth	Metal Halide	1.25 <sup>83</sup>	640 W
Microgreens <sup>84</sup>	T5 HO Fixture	1.0 <sup>85</sup>	358 W
Propagation <sup>86</sup>	T5 HO Fixture	1.0 <sup>87</sup>	234 W
Medical Cannabis – Flowering Stage	High Pressure Sodium	1.7	1,100 W
Medical Cannabis – Vegetative Stage	Metal Halide	1.25 <sup>88</sup>	640 W
Medical Cannabis – Cloning, Seeding, and Propagation	T5 HO Fixture	1.0 <sup>89</sup>	234W
Recreational Cannabis – Flowering Stage	HID/LED/Other	2.2 <sup>90</sup>	850 W <sup>91</sup>
Recreational Cannabis – Vegetative Stage	HID/LED/Other	2.2 <sup>90</sup>	640 W
Recreational Cannabis – Cloning, Seeding, and Propagation	T5/LED/Other	2.2 <sup>90</sup>	234 W

Recreational cannabis cultivation facilities have a separate equipment definition due to Illinois legislation.<sup>92</sup> See cannabis cultivation code from “Cannabis Regulation and Tax Act,” Illinois HB 1438:

*“The Lighting Power Densities (LPD) for cultivation space commits to not exceed an average of 36 watts per gross square foot of active and growing space canopy, or all installed lighting technology shall meet a photosynthetic photon efficacy (PPE) of no less than 2.2 micromoles per joule fixture and shall be featured on the Design Lights Consortium (DLC) Horticultural Specification Qualified Products List (QPL).”*

<sup>81</sup> Erik Runkle and Bruce Bugbee “Plant Lighting Efficiency and Efficacy:  $\mu\text{mol}$  per joule”. Accessed 4/21/2020.

<sup>82</sup> Jesse Remillard and Nick Collins, “Trends and Observations of Energy Use in the Cannabis Industry,” ACEEE, accessed April 17, 2020. Baseline watts per square foot were taken by using typical fixture technology by crop type and dividing by 16 sqft per fixture (a 4’x4’ area is a typical coverage amount for one grow light fixture).

<sup>83</sup> Jacob A. Nelson, Bruce Bugbee, “Economic Analysis of Greenhouse Lighting: Light Emitting Diodes vs. High Intensity Discharge Fixtures.” Utah State University. Accessed 5/6/2020.

<sup>84</sup> Microgreens T5 fixture is based on a 6-lamp high output fixture, based on program experience.

<sup>85</sup> D.S. de Villiers, L.D. Albright, and R. Tuck, “Next Generation, Energy Efficient, Uniform Supplemental Lighting for Closed-System Plant Production.” International Society for Horticultural Science. Accessed 4/8/2022.

<sup>86</sup> Propagation T5 fixture is based on a 4-lamp high output fixture, based on program experience.

<sup>87</sup> D.S. de Villiers, L.D. Albright, and R. Tuck, “Next Generation, Energy Efficient, Uniform Supplemental Lighting for Closed-System Plant Production.” International Society for Horticultural Science. Accessed 4/8/2022.

<sup>88</sup> Jacob A. Nelson, Bruce Bugbee, “Economic Analysis of Greenhouse Lighting: Light Emitting Diodes vs. High Intensity Discharge Fixtures.” Utah State University. Accessed 5/6/2020.

<sup>89</sup> D.S. de Villiers, L.D. Albright, and R. Tuck, “Next Generation, Energy Efficient, Uniform Supplemental Lighting for Closed-System Plant Production.” International Society for Horticultural Science. Accessed 4/8/2022.

<sup>90</sup> Recreational cannabis baseline PPE requirement is either 36 W/sqft or 2.2  $\mu\text{mol}/\text{J}$  and DLC listed. Per HB 1438.

<sup>91</sup> Recreational cannabis baseline wattage was back calculated using the medical cannabis – flowering stage wattage of 1,100 W and adjusted by the IL HB 1438 minimum fixture efficiency of 2.2  $\mu\text{mol}/\text{J}$  compared to the typical baseline of 1.7  $\mu\text{mol}/\text{J}$ .

<sup>92</sup> Illinois legislation Public Act 101-0027 the Cannabis Regulation and Tax Act, Article 20: Adult Use Cultivation Centers, (Section 20-15 (a) (23) a commitment to a technology standard for resource efficiency of the cultivation center facility (B) Lighting)

**DEEMED LIFETIME OF EFFICIENT EQUIPMENT**

The expected measure life is 9.5 years (average rated life of 50,000 hours).<sup>93</sup>

**DEEMED MEASURE COST**

LED Fixture Costs:<sup>94</sup>

≤ 250 Watts = \$ 325.87 per fixture

> 250 Watts = \$ 535.04 per fixture

**LOADSHAPE**

Loadshape C65 – Non-Residential Indoor Agriculture Vegetative Room

Loadshape C66 – Non-Residential Indoor Agriculture Flowering Room

**COINCIDENCE FACTOR**

Summer coincidence factor for vegetative rooms = 0.95

Summer coincidence factor for flowering rooms = 0.76

---



---

**Algorithm**

---



---

**CALCULATION OF ENERGY SAVINGS**

**ELECTRIC ENERGY SAVINGS**

PPF Equivalence Method:

$$\Delta kWh = \left[ \left( \frac{PPF_{Total,i}}{PPE_{BL,i} \times 1000} \right) - kW_{ee,i} \right] \times Hours \times WHF_e$$

$$PPF_{Total,i} = PPF_{Fixture,i} \times Qty_i$$

Where:

$PPF_{Total,i}$  = Total Photosynthetically-active Photon Flux output of the installed efficient fixtures for a specific growth phase, i in units of  $\mu\text{mol/s}$ . Equal to the number of fixtures installed multiplied by the PPF output per fixture.

$PPE_{BL,i}$  = Photosynthetically-active Photon Flux Efficiency of the assumed baseline fixture for a specific growth phase, i in units of  $\mu\text{mol/J}$ . Can be found in the table above.

$PPF_{Fixture,i}$  = The Photosynthetically-active Photon Flux output of an individual fixture installed for a specific growth phase, i in units of  $\mu\text{mol/s}$ .<sup>95</sup>

<sup>93</sup> Based on 50,000 hours lifetime and 5,250 hours per year of use (average hours of use per year using flowering and vegetative rooms).

<sup>94</sup> Focus on Energy Evaluation Business Programs: Measure Life Study Final Report: August 25, 2009

<sup>95</sup> Individual fixture PPF can be sourced directly from the DLC horticulture qualified products list, Design Light Consortium – Horticultural Lighting, Testing and Reporting Requirements for LED-Based Horticultural Lighting, version 2.1, effective September 1, 2021.



- Qty<sub>i</sub> = The installed quantity of efficient fixtures.
- i = An indicator used to separate growth phases of products or different plants. “i” can be used to separate “Flowering” and “Vegetative”, or different crop types, such as “Flowering Crops (tomatoes and peppers)” and “Microgreens”.
- 1000 = Watts to kilowatts conversion factor
- kW<sub>ee,i</sub> = Total power of the installed fixtures for a specific growth phase, i.
- Hours = Annual operating hours. See table below for typical hours of operation breakdown by crop type.

Crop Types	Hours of Operation per Day <sup>96</sup>	Annual Hours of Operation <sup>97</sup>
Flowering Crops (Tomatoes/Peppers)	12	4,200
Vegetative/Propagation Growth	18	6,300
Microgreens	18	6,300
Medical Cannabis – Flower Stage	12	4,200
Recreational Cannabis – Flowering Stage	12	4,200

- WHFe = 1.21<sup>98</sup> if cooling or unknown or 1.00 if none; waste heat factor for energy to account for cooling savings from efficient lighting in cooled buildings.

**For example**, a recreational cannabis growth facility is installing 100 efficient LED fixtures in their flowering spaces. Using the manufacturer and model number, the DLC Qualified Products List for horticulture lighting lists these fixtures as consuming 529W and having a Photosynthetic Photon Efficiency (PPE) of 3.3 μmol/J and producing 1,722 μmol/s. One hundred (100) fixtures at 529W each is a total lighting power of 52.9 kW. The baseline PPE is 2.2 μmol/J, as dictated by IL HB 1438. The total flux output and annual energy savings calculations are shown below.

$$PPF_{Total,i} = (1,722 \mu\text{mol/s}) \times 100 \text{ fixtures} = 172,200 \mu\text{mol/s}$$

$$\Delta kWh = \left[ \left( \frac{172,200 \frac{\mu\text{mol}}{\text{s}}}{2.2 \frac{\mu\text{mol}}{\text{J}} \times 1000} \right) - (52.9 \text{ kW}) \right] \times 4,200 \text{ hours} \times 1.21$$

$$= 128,944 \text{ kWh}$$

**SUMMER COINCIDENT PEAK DEMAND SAVINGS**

$$\Delta kW = \left[ \left( \frac{PPF_{Total,i}}{PPE_{BL,i} \times 1000} \right) - kW_{ee,i} \right] \times CF \times WHF_d$$

<sup>96</sup> Sole-Source Lighting of Plants. Technically Speaking by Erik Runkle. Michigan State University Extension. September 2017. Accessed: 7/29/2019.

<sup>97</sup> Annual hours of operation were found by multiplying hours per day by 350 operating days per year. Assuming 5 crop cycles with 3 days of downtime between each cycle

<sup>98</sup> Waste heat factor for cooling savings calculation can be found in the Indoor Agriculture Loadshapes excel file.

Where:

WHF<sub>d</sub> = 1.22 if cooling or 1.00 if none; waste heat factor for demand to account for cooling savings from efficient lighting in cooled buildings.

CF = 0.95 for vegetative crops or 0.76 for flowering crops

**For example**, a recreational cannabis growth facility is installing 100 efficient LED fixtures in their flowering spaces. Using the manufacturer and model number, the DLC Qualified Products List for horticulture lighting lists these fixtures as consuming 529W and having a Photosynthetic Photon Efficiency (PPE) of 3.3 μmol/J and producing 1,722 μmol/s. One hundred (100) fixtures at 529W each is a total lighting power of 52.9 kW. The baseline PPE is 2.2 μmol/J, as dictated by IL HB 1438. The total flux output and peak demand savings calculations are shown below.

$$PPF_{Total,i} = (1,722 \mu\text{mol/s}) \times 100 \text{ fixtures} = 172,200 \mu\text{mol/s}$$

$$\Delta kWh = \left[ \left( \frac{172,200 \frac{\mu\text{mol}}{\text{s}}}{2.2 \frac{\mu\text{mol}}{\text{J}} \times 1000} \right) - (52.9 \text{ kW}) \right] \times 0.76 \times 1.22$$

$$= 23.526 \text{ kW}$$

**FOSSIL FUEL SAVINGS**

N/A

**WATER AND OTHER NON-ENERGY IMPACT DESCRIPTIONS AND CALCULATION**

N/A

**DEEMED O&M COST ADJUSTMENT CALCULATION**

Any costs associated with moving the LED lighting fixture to different heights throughout the different growing phases should also be included as an O&M consideration.

**MEASURE CODE: CI-AGE-GROW-V05-230101**

**REVIEW DEADLINE: 1/1/2024**

## 4.1.12 Swine Heat Pads

### DESCRIPTION

This measure applies to the large Commercial and Industrial sector, specifically for the agriculture industry. Swine farmers will typically keep their newborn piglets alongside their mothers (sows) for up to three to four weeks until they gain sufficient weight and can be moved to a nursery barn. During this farrowing stage, the piglets must be kept at temperatures ranging from 32 to 35°C (90 to 95°F). A sow and her piglets are kept in private farrowing crates, where the sow is kept in a separate and railed cage. This allows the piglets to still suckle from their mother and keeps the sow from crushing her piglets. These farrowing crates can be arranged in single or double systems. Typically, farmers will utilize a heat lamp as the primary heating source for these piglets, which can range from 125 W to 250 W and have an average measure life of 5,000 hours. More energy efficient technology has emerged in the form of heated mats. These mats require significantly less energy than a traditional heat lamp and have no known negative impacts on piglet health. Heating mats come in two options, single (typically rated at  $\leq 100\text{W}$ ) or double (typically rated at  $\leq 200\text{W}$ ) mats. Single mats serve one litter, and double mats serve two litters.

### DEFINITION OF EFFICIENT EQUIPMENT

The use of heat mats in swine farrowing will result in electrical savings for the customer. Research has also shown that newborn piglets do not prefer mat heating over lamp heating, but as they grow, they tend to prefer mat heating. Applied research in large industrial settings found no significant differences between lamp and mat heating on the behavior and well-being of piglets. Therefore, the only difference to note between the two methods is the energy saved in using heating mats.

### DEFINITION OF BASELINE EQUIPMENT

The baseline measure for swine farrowing heating is heat lamps, typically ranging from 125 to 250 Watts. Most studies conducted on swine farrowing heat lamps have used 125 watt or 175 watt lamps per litter.<sup>99,100</sup>

### DEEMED LIFETIME OF EFFICIENT EQUIPMENT

The measure life of a farrowing heat mat is 5 years.<sup>101</sup>

### DEEMED MEASURE COST

Heat mat prices will vary somewhat with size but a typical single mat costs \$155 and double mat costs \$280.<sup>102</sup> Additional costs can be incurred if a thermostat controller is included, these start at \$240 but vary widely depending on controller complexity.

### LOADSHAPE

Loadshape C04 - Non-Residential Electric Heating

### COINCIDENCE FACTOR

The coincidence factor is assumed to be 0.018.<sup>103</sup>

---

<sup>99</sup>Zhang, Q. and H. Xin, "Responses of Piglets to Creep heat Type and Location in Farrowing Crate," Applied Engineering in Agriculture (2001): Vol. 17(4) 515-519

<sup>100</sup> "Research at Puratone Confirms Effectiveness and Extensive Energy Savings of Heat Pads," Manitoba Hydro Power Smart

<sup>101</sup> Professional judgement based on Iowa Energy Efficiency Statewide Technical Reference Manual 2018 Volume 3: Nonresidential Measures, Agriculture Equipment: 3.1.9 Heat Mat, Posted July 12<sup>th</sup>, 2017

<sup>102</sup> Hog Slat. (2023). Heat Pad. Online pricing catalogue for agriculture and livestock equipment.

<sup>103</sup> Coincidence factor is taken from the IL TRM loadshape C04 – Non-residential Electric Loadshape.

---



---

**Algorithm**

---

**CALCULATION OF ENERGY SAVINGS**

**ELECTRIC ENERGY SAVINGS**

$$kWh_{saved} = kWh_{base} - kWh_{EE} - kWh_{controller}$$

$$kWh_{base} = \frac{Crates_{total} \times Hours \times Fixture_{crate} \times Lamp_{fixture} \times Wattage_{lamp}}{1000 \frac{Watts}{kW}}$$

$$kWh_{EE} = \frac{Hours \times (Mats_{single} \times Wattage_{single} + Mats_{double} \times Wattage_{double})}{1000 \frac{Watts}{kW}}$$

$$kWh_{controller} = \frac{Hours \times Rooms \times (MSU_{room} \times MSU_{wattage})}{1000 \frac{Watts}{kW}}$$

Where:

$$Crates_{total} = (Crates_{single-row} + Crates_{double-row}) \times Rows \times Rooms$$

$$Mats_{single} = Crates_{single-row} \times Rows \times Rooms$$

$$Mats_{double} = Crates_{double-row} \times Rows \times Rooms$$

- Crates<sub>total</sub> = Number of Farrowing Crates
- Crates<sub>single-row</sub> = Number of single crates in a row
- Crates<sub>double-row</sub> = Number of double crates in a row
- Rows = Number of rows in a room
- Rooms = Number of rooms in a farrowing barn
- Mats<sub>single</sub> = Number of single mats
- Mats<sub>double</sub> = Number of double mats
- Wattage<sub>single</sub> = Default 90W with no MSU, 61W with MSU\*; Wattage of a single heat mat
- Wattage<sub>double</sub> = Default 180W with no MSU, 122W with MSU\*; Wattage of a double heat mat
- Hours = Default 5,105 hours;<sup>104</sup> Annual hours of operation
- Fixture<sub>crate</sub> = Number of heat lamp fixtures per farrowing crate
- Lamp<sub>fixture</sub> = Number of heat lamps per fixture
- Wattage<sub>lamp</sub> = Default 125W or 175W; Heat lamp wattage

---

<sup>104</sup> While heat mat hours do vary from heat lamps slightly, the savings assumptions match heat lamp hours for consistency. Calculation method from Iowa State University farm manager (Ben Drescher): "At minimum I'd say they are on 24-7 from Oct-March and March-May, and 12 hours a day June-September 8 hours a day. You'd also take off for power washing etc. so if you had a 24 day turn in a farrowing room you'd run them for 21 days and turn the room subtract 3 days from x 15 turns a year - resulting in 5120 hours." Cadmus did not round data and estimated 5,105 hours. Email sent 10/23/15. "FW: Heat lamp bulbs". Itron benchmarked the HOU with their own analysis which resulted in 5,109 hours: 30.42 days/month; 3 months (summer) run 33% of time; 6 months run 50% of time; 3 months (winter) run full time.

MSU<sub>room</sub> = Default 1; Number of master sensor units (MSU) per room

MSU<sub>wattage</sub> = Default 75W; Wattage of master sensor unit

**DEFAULT SAVINGS FOR SINGLE UNIT REPLACEMENT**

Replacement Type	Baseline Heat Lamp	Annual kWh Savings
Single Mat replacing one Heat Lamp w/o MSU	125W	178.7
Single Mat replacing one Heat Lamp w/ MSU		326.7
Double Mat replacing two Heat Lamps w/o MSU		357.4
Double Mat replacing two Heat Lamps w/ MSU		653.4
Single Mat replacing one Heat Lamp w/o MSU	175W	433.9
Single Mat replacing one Heat Lamp w/ MSU		582.0
Double Mat replacing two Heat Lamps w/o MSU		867.9
Double Mat replacing two Heat Lamps w/ MSU		1163.9

**SUMMER COINCIDENT PEAK DEMAND SAVINGS**

$$kW_{Saved} = (kWh_{Saved}/Hours) \times CF$$

Where:

kWh<sub>Saved</sub> = kWh savings, see above equation and table.

Hours = Operating hours, 5,105.

CF = Coincidence Factor, 0.018.<sup>105</sup>

**DEFAULT SAVINGS FOR SINGLE UNIT REPLACEMENT**

Replacement Type	Baseline Heat Lamp	Peak kW Savings
Single Mat replacing one Heat Lamp w/o MSU	125W	0.0006
Single Mat replacing one Heat Lamp w/ MSU		0.0012
Double Mat replacing two Heat Lamps w/o MSU		0.0013
Double Mat replacing two Heat Lamps w/ MSU		0.0023
Single Mat replacing one Heat Lamp w/o MSU	175W	0.0015

<sup>105</sup> Coincidence factor is taken from the IL TRM loadshape C04 – Non-residential Electric Loadshape.

Replacement Type	Baseline Heat Lamp	Peak kW Savings
Single Mat replacing one Heat Lamp w/ MSU		0.0021
Double Mat replacing two Heat Lamps w/o MSU		0.0027
Double Mat replacing two Heat Lamps w/ MSU		0.0041

**FOSSIL FUEL SAVINGS**

N/A

**WATER AND OTHER NON-ENERGY IMPACT DESCRIPTIONS AND CALCULATION**

N/A

**DEEMED O&M COST ADJUSTMENT CALCULATION**

Approximately 1% of mats are likely to be damaged by swine each year and require full replacement.

Additionally, depending on the flooring, some mats may become loose on steel slated floors. This can be prevented by buying mats that have a channel or groove where it sits in the partition. Another option is to buy tie down clips that cost approximately \$24 per double mat.<sup>106</sup>

The NPV for replacement heat lamps and annual levelized replacement costs using the societal real discount rate of 0.42% are presented below. The O&M cost adjustments are based on a 1-year measure life for heat lamps and a 5-year analysis period for heat pads. The measure life assumptions indicate an annual lamp replacement cost for the baseline equipment. The heat lamp replacement cost is assumed to be \$5.50.<sup>107</sup>

Replacement Type	NPV of replacement costs for period	Levelized annual replacement cost savings
Single Mat replacing one Heat Lamp	\$20.58	\$4.94
Double Mat replacing two Heat Lamps	\$41.16	\$8.98

**MEASURE CODE: CI-AGE-HPAD-V02-240101**

**REVIEW DEADLINE: 1/1/2029**

<sup>106</sup> Franklin Energy field experience

<sup>107</sup> The cost of a replacement heat lamp bulb is sourced from an average of available products via online pricing for agriculture equipment and heat lamps. For more information on the cost of a heat lamp and the derivation of O&M cost savings, please see: "Swine Heat Pads\_OM.xlsx".

### 4.1.13 Irrigation Pump VFD

#### DESCRIPTION

This measure applies to variable speed drives (VSD) installed on irrigation pump motors for the agriculture industry. This characterization does not apply to positive displacement pumps. The VFD will modulate the speed of the motor when it does not need to run at full load. Since the power of the motor is proportional to the cube of the speed for these types of applications, significant energy savings will result.

This measure was developed to be applicable to the following program types: TOS, RF. If applied to other program types, the measure savings should be verified.

#### DEFINITION OF EFFICIENT EQUIPMENT

The VFD is applied to a motor that does not yet have one. The irrigation system must have a variable load, and installation is to include the necessary controls as determined by a qualified engineer. Savings are based on application of VFDs to a range of baseline load conditions.

#### DEFINITION OF BASELINE EQUIPMENT

The time of sale baseline is a new motor installed without a VFD or other methods of control. The retrofit baseline is an existing motor operating as is. Retrofit baselines may or may not include guide vanes, throttling valves, or other methods of control. This information shall be collected from the customer.

Installations of new equipment with VFDs that are required by IECC 2018 as adopted by the State of Illinois are not eligible to claim savings<sup>108</sup>.

#### DEEMED LIFETIME OF EFFICIENT EQUIPMENT

The expected measure life is 15 years.<sup>109</sup>

#### DEEMED MEASURE COST

Customer provided costs will be used when available. Default measure costs<sup>110</sup> are noted below for up to 75 hp motors. Custom costs must be gathered from the customer for motor sizes not listed below.

HP	Cost
1-9 HP	\$1,874
10-19 HP	\$2,967
20-29 HP	\$4,060
30-39 HP	\$5,154
40-49 HP	\$6,247
50-59 HP	\$7,340
60-69 HP	\$8,433
70-75 HP	\$9,526

#### LOADSHAPE

Loadshape C59 – Agriculture and Water Pumping

<sup>108</sup> Utah State University Extension. *Variable Frequency Drives for Irrigation Pumps* Variable. Frequency Drives for Irrigation Pumps. Published March 2020

<sup>109</sup> DEER 2008.

<sup>110</sup> Average from IPL and MidAmerican VFD reported costs from rebate forms. IPL & MIa VFD Costs.xls

**COINCIDENCE FACTOR**

The installation of a VFD on an irrigation pump should not cause any energy reduction during peak runtimes.

**Algorithm**

**CALCULATION OF ENERGY SAVINGS**

**ELECTRIC ENERGY SAVINGS**

$$\Delta kWh = kWh_{Base} - kWh_{VFD}$$

$$kWh_{Base} = \sum_1^{\eta} HP_{\eta} * 0.746 \frac{kW}{HP} * Hours_{year} * \%Hours_{\eta}$$

$$kWh_{VFD} = \sum_1^{\eta} HP_{VFD,\eta} * 0.746 \frac{kW}{HP} * Hours_{year} * \%Hours_{\eta}$$

$$HP_{\eta} = \frac{Flow_{\eta} * Head_{\eta}}{3960 * (Eff_{pump} * Eff_{motor})}$$

$$HP_{VFD,\eta} = \frac{Flow_{\eta} * Head_{VFD,\eta}}{3960 * (Eff_{pump} * Eff_{VFD} * Eff_{motor})}$$

$$Hours_{year} = \frac{Acres * Irrigation}{12 \frac{in}{ft} * 60 \frac{min}{hr} * GPM_{system} / \left( 7.481 \frac{gal}{ft^3} * 43,560 \frac{ft^2}{acre} \right)}$$

Where:

- kWh<sub>Base</sub> = Annual energy required for the baseline pump condition
- kWh<sub>VFD</sub> = Annual energy required with a VFD pump installed
- HP<sub>η</sub> = Baseline horsepower required for a given flow rate
- HP<sub>VFD,η</sub> = Horsepower required for a given flow rate with the VFD installed
- Hours<sub>year</sub> = Annual Hours of irrigation
- %Hours<sub>η</sub> = Percent of time irrigation pump will be operating at a given flow rate
- η = Number of data points needed or collected
- Flow<sub>η</sub> = Flow rate at a given data point in gallons per minute, use actual values
- Head<sub>η</sub> = Pressure head at a given data point in feet, use actual values
- Head<sub>VFD,η</sub> = Pressure head at a given data point in feet with a VFD
- Eff<sub>pump</sub> = Percent efficiency of the pump, taken from manufacturers pump curve
- Eff<sub>motor</sub> = Percent efficiency of the pump motor

**NEMA Premium Efficiency Motors Default Efficiencies<sup>111</sup>**

<sup>111</sup> Douglass, J. (2005). Induction Motor Efficiency Standards. Washington State University and the Northwest Energy Efficiency Alliance, Extension Energy Program, Olympia, WA, October 2005.



Size HP	Open Drip Proof (ODP)			Totally Enclosed Fan-Cooled (TEFC)		
	# of Poles			# of Poles		
	6	4	2	6	4	2
	Speed (RPM)			Speed (RPM)		
	1200	1800 Default	3600	1200	1800	3600
1	0.825	0.855	0.770	0.825	0.855	0.770
1.5	0.865	0.865	0.840	0.875	0.865	0.840
2	0.875	0.865	0.855	0.885	0.865	0.855
3	0.885	0.895	0.855	0.895	0.895	0.865
5	0.895	0.895	0.865	0.895	0.895	0.885
7.5	0.902	0.910	0.885	0.910	0.917	0.895
10	0.917	0.917	0.895	0.910	0.917	0.902
15	0.917	0.930	0.902	0.917	0.924	0.910
20	0.924	0.930	0.910	0.917	0.930	0.910
25	0.930	0.936	0.917	0.930	0.936	0.917
30	0.936	0.941	0.917	0.930	0.936	0.917
40	0.941	0.941	0.924	0.941	0.941	0.924
50	0.941	0.945	0.930	0.941	0.945	0.930
60	0.945	0.950	0.936	0.945	0.950	0.936
75	0.945	0.950	0.936	0.945	0.954	0.936
100	0.950	0.954	0.936	0.950	0.954	0.941
125	0.950	0.954	0.941	0.950	0.954	0.950
150	0.954	0.958	0.941	0.958	0.958	0.950
200	0.954	0.958	0.950	0.958	0.962	0.954
250	0.954	0.958	0.950	0.958	0.962	0.958
300	0.954	0.958	0.954	0.958	0.962	0.958
350	0.954	0.958	0.954	0.958	0.962	0.958
400	0.958	0.958	0.958	0.958	0.962	0.958
450	0.962	0.962	0.958	0.958	0.962	0.958
500	0.962	0.962	0.958	0.958	0.962	0.958

- Eff<sub>VFD</sub> = Percent efficiency of the VFD  
= 97%<sup>112</sup>
- Acres = Size of the field that is being irrigated in acres
- Irrigation = Gross irrigation required in inches per year
- GPM<sub>System</sub> = Required system flow rate in gallons per minute

<sup>112</sup> Estimated typical VFD efficiency, as sourced from; “Chapter 18: Variable Frequency Drive Evaluation Protocol”, The Uniform Methods Project: Methods for Determining Energy Efficiency Savings for Specific Measures, NREL, December 2014 (pg. 2)

**SUMMER COINCIDENT PEAK DEMAND SAVINGS**

There are no expected peak demand impacts for this measure.

**FOSSIL FUEL SAVINGS**

There are no expected fossil fuel impacts for this measure.

**WATER AND OTHER NON-ENERGY IMPACT DESCRIPTIONS AND CALCULATION**

While there may be water savings from the installation of a VFD on an irrigation pump, they are not being included at this time. Any water savings calculations should be handled in a custom manner.

**DEEMED O&M COST ADJUSTMENT CALCULATION**

N/A

**MEASURE CODE: CI-AGE-PUMP-V01-220101**

**REVIEW DEADLINE: 1/1/2025**

### 4.1.14 High Efficiency Grain Dryer

#### DESCRIPTION

This measure characterizes the energy savings from the replacement of an existing inefficient grain dryer with a new efficient grain dryer (Early Replacement incentive program). Alternatively, this measure is for the purchase of a new high efficiency grain dryer instead of a new standard efficiency grain dryer for an existing facility (Time of Sale program) or a new facility (New Construction incentive program). Energy savings are achieved by drying grain more efficiently through: improved dryer air flow design, improved dryer controls, warm air heat recovery, and burner efficiency improvements. Efficient dryers also have the benefits of increased throughput capacity and reduced annual hours of operation.

This measure was developed to be applicable to the following program types: TOS, EREP, and NC. If applied to other program types, the measure savings should be verified.

#### DEFINITION OF EFFICIENT EQUIPMENT

The efficient equipment is assumed to be a new, high efficiency grain dryer. Bushels per hour must be provided by the manufacturer, as rated at 5% moisture removal rate per bushel processed.

#### DEFINITION OF BASELINE EQUIPMENT

The baseline for this measure is a standard efficiency grain dryer currently on the market. Bushels per hour must be provided by the manufacturer, as rated at 5% moisture removal rate per bushel processed.

#### DEEMED LIFETIME OF EFFICIENT EQUIPMENT

The measure life for the energy-efficient grain dryer is deemed to be 20 years<sup>113</sup>.

#### DEEMED MEASURE COST

If known, the actual material and labor cost of installation should be used. If unknown, the cost of the measure is assumed to be the values summarized in the table below:

Tier (bushels per hour)	Tier (annual bushels)	High-Efficiency Dryer Total Installation Cost (for Early Replacement only)	Average Incremental Cost of High-Efficiency Dryer vs Standard Dryer	Average Incremental Cost of Variable Speed Drive added to Cost of High-Efficiency Dryer
<500	< 170,000	\$83,000 (Based on baseline price of \$50,000 + (\$50/Bu/hr * 250 Rated Bu/hr) + Incremental Cost of High Efficiency)	\$20,000	\$4,000 (Based on baseline price of \$2,500 + 0.046kW/Bu/hr * 250 Rated Bu/hr) *\$100/kW)
≥ 500 and < 1000	≥ 170,000 and < 330,000	\$118,000 (Based on 750 Rated Bu/hr)	\$30,000	\$6,000 (Based on 750 Rated Bu/hr)

<sup>113</sup> Iowa State University Ag Extension, “Computing a Grain Storage Rental Rate”, October 2013. The useful life of grain storage bins was estimated to be between 15 and 25 years and the drying equipment useful life was estimated to be between 10 and 12 years. Combined with engineering judgement, the estimated measure life for a high efficiency grain dryer is estimated to be 20 years, which is corroborated by the Wisconsin Focus on Energy 2021 Technical Reference Manual, Cadmus, Public Service Commission of Wisconsin – Energy Efficient Grain Dryer.

Tier (bushels per hour)	Tier (annual bushels)	High-Efficiency Dryer Total Installation Cost (for Early Replacement only)	Average Incremental Cost of High-Efficiency Dryer vs Standard Dryer	Average Incremental Cost of Variable Speed Drive added to Cost of High-Efficiency Dryer
≥ 1000 and < 2000	≥ 330,000 and < 670,000	\$165,000 (Based on 1,500 Rated Bu/hr)	\$40,000	\$9,000 (Based on 1,500 Rated Bu/hr)
≥ 2000 and < 3500	≥ 670,000 and < 1,200,000	\$258,000 (Based on 2,750 Rated Bu/hr)	\$70,000	\$15,000 (Based on 2,750 Rated Bu/hr)
≥ 3500 and ≤ 5000	≥ 1,200,000 and ≤ 1,700,000	\$363,000 (Based on 4,250 Rated Bu/hr)	\$100,000	\$22,000 (Based on 4,250 Rated Bu/hr)
> 5000	> 1,700,000	\$488,000 (Based on 6,250 Rated Bu/hr)	\$125,000	\$31,000 (Based on 6,250 Rated Bu/hr)

Early Replacement: The full installation cost is provided in the table above. The assumed deferred cost (after 6.5 years [one third of useful life]) of replacing existing equipment with a new baseline unit is assumed to be the installation cost discounted to present value using the nominal discount rate.

**LOADSHAPE**

Loadshape NRE11 – Non-Residential Agriculture

**COINCIDENCE FACTOR**

There are no summer peak savings associated with this measure as it is assumed grain dryers do not operate during peak summer months.

---

**Algorithm**

---

**CALCULATION OF ENERGY SAVINGS**

**ELECTRIC ENERGY SAVINGS**

If grain dryer is heated exclusively with electricity:

$$\Delta kWh = \text{Bushels/Hr}_{\text{Capacity}} * \text{Annual\_Hr\_Use}_{\text{Rated\_Capacity}} * (\text{Moisture\_}\%_{\text{In}} - \text{Moisture\_}\%_{\text{Out}}) * \text{Grain\_Lb\_Moisture\_}\%_{\text{Bushel}} * \text{Btu/Lb}_{\text{Evap}} * (1 / \text{Dryer\_Effcy}_{\text{Std}} - 1 / \text{Dryer\_Effcy}_{\text{Eff}}) / 3,412 + (\text{Dryer\_Fan\_Power}_{\text{Standard}} - \text{Dryer\_Fan\_Power}_{\text{Efficient}}) * \text{Bushels/Hr}_{\text{Capacity}} * \text{Annual\_Hr\_Use}_{\text{Rated\_Capacity}}$$

Where:

$\text{Bushels/Hr}_{\text{Capacity}}$  = Capacity of Grain Dryer in Bushels/Hr when reducing grain moisture content by 5%

Annual\_Hr\_Use<sub>@Rated\_Capacity</sub> = Average annual hours of use of typical grain dryer  
 = Deemed value of 336.3 hr/year<sup>114</sup>

Annual hours of use were calculated based on following table. Deemed value is arithmetic average of Average Use per Year

Savings Tier (Bushels/hr) from manufacturer	Savings Tier (Bushels/yr)	Average Hours/yr @ Rated Capacity
>= 0 Bu/Hr	170,000	340
>= 500 Bu/Hr	330,000	330
>= 1,000 Bu/Hr	670,000	335
>= 2,000 Bu/Hr	1,200,000	343
>= 3,500 Bu/Hr	1,700,000	340
>= 5,000 Bu/Hr	2,475,000	330

Moisture\_%<sub>in</sub> = 23%<sup>115</sup>, a deemed value representing average % moisture in grain arriving at grain dryer facility<sup>116</sup>

Moisture\_%<sub>out</sub> = 15%<sup>117</sup>, a deemed value representing average % moisture in grain after being dried at grain dryer facility

Grain\_Lb\_Moisture\_/\_Bushel = Lookup value from following table, Lb Moisture per Bushel per 1% of moisture content reduction. <sup>118</sup>

<sup>114</sup> Alliant Energy Custom Rebate project data from 2012-2014; original Alliant table was modified, adding a new column of hours per year use and renaming labels. Annual tier production quantities (bushels/yr) were divided by the maximum nominal tier capacities (bushels/hr @ rated capacity) to obtain Hours per Year @ Rated Capacity. Arithmetic average hours of use was 336.3 per year.

<sup>115</sup> Wisconsin Focus on Energy project data; 13 recent grain dryer projects in Wisconsin were used as the source of average pre- and post- moisture content (23% and 15%, respectively) and baseline and proposed dryer efficiency.

<sup>116</sup> The National Corn Handbook. “Energy Conservation and Alternative Sources for Corn Drying.” NCH-14, page 3, Table 4. <http://corn.agronomy.wisc.edu/Management/NCH.aspx>

<sup>117</sup> Wisconsin Focus on Energy project data; 13 recent grain dryer projects in Wisconsin were used as the source of average pre- and post- moisture content (23% and 15%, respectively) and baseline and proposed dryer efficiency.

<sup>118</sup> “Tables for Weights and Measurement: Crops”. Murhpy, William J., **Error! Hyperlink reference not valid.**, Accessed August 19, 2020. Table shown was modified from the original by eliminating some redundant rows for similar crops, and by adding a new column that calculates pounds of moisture evaporated per Standard Bushel per 1% moisture reduction by the dryer.

Grain Type	Weight of "Standard Bushel"	Lb Moisture/Bu/1% Evap
Alfalfa	60.0 Lb/Std Bu	0.60 Lb Evap/Std Bu/Delta%
Barley	48.0 Lb/Std Bu	0.48 Lb Evap/Std Bu/Delta%
Clover	60.0 Lb/Std Bu	0.60 Lb Evap/Std Bu/Delta%
Corn, Shelled (15.5%)	56.0 Lb/Std Bu	0.56 Lb Evap/Std Bu/Delta%
Corn, Ear (15.5%)	68.4 Lb/Std Bu	0.68 Lb Evap/Std Bu/Delta%
Cotton	32.0 Lb/Std Bu	0.32 Lb Evap/Std Bu/Delta%
Cowpeas	60.0 Lb/Std Bu	0.60 Lb Evap/Std Bu/Delta%
Flax	60.0 Lb/Std Bu	0.60 Lb Evap/Std Bu/Delta%
Grass, Exc Timothy	14.0 Lb/Std Bu	0.14 Lb Evap/Std Bu/Delta%
Grass, Timothy	45.0 Lb/Std Bu	0.45 Lb Evap/Std Bu/Delta%
Lespedeza	45.0 Lb/Std Bu	0.45 Lb Evap/Std Bu/Delta%
Millet	80.0 Lb/Std Bu	0.80 Lb Evap/Std Bu/Delta%
Oats	32.0 Lb/Std Bu	0.32 Lb Evap/Std Bu/Delta%
Rape	60.0 Lb/Std Bu	0.60 Lb Evap/Std Bu/Delta%
Tye	56.0 Lb/Std Bu	0.56 Lb Evap/Std Bu/Delta%
Sorghum, Forage	50.0 Lb/Std Bu	0.50 Lb Evap/Std Bu/Delta%
Sorghum, grain (13.0%)	56.0 Lb/Std Bu	0.56 Lb Evap/Std Bu/Delta%
Soybeans	60.0 Lb/Std Bu	0.60 Lb Evap/Std Bu/Delta%
Sudan grass	28.0 Lb/Std Bu	0.28 Lb Evap/Std Bu/Delta%
Sunflower, oil type	28.0 Lb/Std Bu	0.28 Lb Evap/Std Bu/Delta%
Trefoil, Birdsfoot	60.0 Lb/Std Bu	0.60 Lb Evap/Std Bu/Delta%
Vetch	60.0 Lb/Std Bu	0.60 Lb Evap/Std Bu/Delta%
Wheat (13.5%)	60.0 Lb/Std Bu	0.60 Lb Evap/Std Bu/Delta%

Btu/Lb<sub>Evap</sub> = 990 Btu per Lb of Water Evaporated; an engineering constant

Dryer\_Effcy<sub>Std</sub> = Electric grain dryer efficiency of a standard-efficiency electric bin dryer, expressed as a %, defined as Btu of moisture evaporated in the dryer divided by the heating Btu input into the dryer

=71%<sup>119</sup>, a deemed value, based on the following table, which represents BTU/Lb evaporated and equivalent Overall Efficiency for the dryers and heating sources used in this TRM:

<sup>119</sup> "Reducing Grain Drying Costs". Sanford, Scott., University of Wisconsin Rural Energy Program, 2013. Notes 20-30% savings in bin dryers through the use of stirrers and ambient air low temperature drying. Based on this, 71% is used as a conservative value, but Actual values can be used if available. Accessed August 19, 2020.

Grain Dryer Description	Dryer Efficiency (Dryer_Effcy)		Dryer Fan Power (Dryer_Fan_Power)
	Dryer_Effcy	Btu/lb Water Evaporated (Btu/lb Water)	kW / Bushel
Baseline Gas Grain Dryer w/ Constant Speed Fan Operation	44%	2,241	0.044
Efficient Gas Grain Dryer w/ Constant Speed Fan Operation	61%	1,625	0.044
Efficient Gas Grain Dryer w/ Damper Fan Operation	61%	1,625	0.035
Efficient Gas Grain Dryer w/ Fan VFD	61%	1,625	0.002
Baseline Electric Bin Grain Dryer w/ Constant Speed Fan Operation	71%	1,400	0.44
Efficient Electric Bin Grain Dryer w/ Constant Speed Fan Operation	88%	1,120	0.044
Efficient Electric Bin Grain Dryer w/ Damper Fan Operation	88%	1,120	0.035
Efficient Electric Bin Grain Dryer w/ Fan VFD	88%	1,120	0.002

Dryer\_Effcy<sub>eff</sub> = 88%<sup>120</sup>, a deemed value; or Actual. See prior footnote for derivation of this value.

3,412 = Conversion factor of kWh to Btu; engineering constant.

Dryer\_Fan\_Power<sub>Standard</sub> = 0.044 kW/Bu<sup>121</sup>, from above table, a deemed value, based on the following average standard bin dryer operational parameters, and the engineering equation:

$$\text{kW/Bu}_{Std} = \text{CFM/Bu}_{Std} * \text{in.}_{wc}_{Std} / 6,354 / \text{Fan\_Efficiency}_{Std} * 0.746 / \text{Motor\_Effcy}_{Std}.$$

In the above equation, the following deemed constants are typical for standard-efficiency Grain Dryers:

Where:

CFM/Bu<sub>Std</sub> = 61 CFM/Bu

in.<sub>wc</sub><sub>Std</sub> = 3.0" wc

6,354 = Units conversion from cfm \* in. wc. / Fan\_Efficiency to BHP

Fan\_Efficiency<sub>Std</sub> = 60%

0.746 = Units conversion from BHP to kW

Motor\_Effcy<sub>Std</sub> = 80%.

$$\text{kW/Bu} = 61 * 3.0 / 6,354 / 60\% * 0.746 / 80\% \\ = 0.044 \text{ kW/Bu}$$

<sup>120</sup> Alliant Energy Custom Rebate project data from 2012-2014; same comments apply as in prior footnote.

<sup>121</sup> The Standard Dryer Fan Power using the fan brakehorsepower equation.

Dryer\_Fan\_Power<sub>Efficient</sub> = 0.035 kW/Bu<sup>122</sup>, if fan volume is controlled using outlet damper, or  
 = 0.002 kW/Bu, if fan volume is controlled using VFD.

Above values are deemed constants, based on the following average high-efficiency bin dryer operational parameters, and the engineering equation:

$$\text{kW/Bu}_{\text{Eff}} = \text{CFM/Bu}_{\text{Eff}} * \text{in.}_{\text{wc}_{\text{Eff}}} / 6,354 / \text{Fan\_Efficiency}_{\text{Eff}} * 0.746 / \text{Motor\_Effcy}_{\text{Eff}} / \text{Drive\_Effcy}_{\text{Eff}}$$

In the above equation, the following deemed constants are assumed to apply to high-efficiency Grain Dryers:

Where:

- CFM/Bu<sub>Eff</sub> = 22
- in.\_wc<sub>Eff</sub> = 4.4" if Outlet Damper control; 0.4" if VFD control
- 6,354 = Units conversion from cfm \* in. wc. / Fan\_Efficiency to BHP
- Fan\_Efficiency<sub>Eff</sub> = 60%
- 0.746 = Units conversion from BHP to kW
- Motor\_Effcy<sub>Eff</sub> = 80%
- Drive\_Effcy<sub>Eff</sub> = 100% if Outlet Damper control; 95% if VFD control.

For high-efficiency dryer with VFD control:

$$\begin{aligned} \text{kW/Bu} &= 22 * 0.4 / 6,354 / 60\% * 0.746 / 80\% / 95\% \\ &= 0.002 \text{ kW/Bu} \end{aligned}$$

**SUMMER COINCIDENT PEAK DEMAND SAVINGS**

N/A

**FOSSIL FUEL SAVINGS**

If grain dryer is heated exclusively with natural gas:

$$\Delta\text{Therms} = \text{Bushels/Hr}_{\text{Capacity}} * \text{Annual\_Hr\_Use}_{\text{@Rated\_Capacity}} * (\text{Moisture}_{\%_{\text{In}}} - \text{Moisture}_{\%_{\text{Out}}}) * \text{Grain\_Lb\_Moisture\_}\_ \text{Bushel} * \text{Btu/Lb}_{\text{Evap}} * (1 / \text{Dryer\_Effcy}_{\text{Std}} - 1 / \text{Dryer\_Effcy}_{\text{Eff}}) / 100,000$$

Where:

100,000 = Conversion factor of Therms to Btu; engineering constant.

All variables are as defined and derived in the preceding electric savings calculations, but using values in the dryer efficiency table above for Baseline or Efficient "Gas or Propane Grain Dryer".

Note: When a variable frequency drive (VFD) is incorporated on the drying fan, electrical savings may be claimed by the fan power derivation in the electric savings algorithm for additive electrical savings for a gas heated grain dryer.

<sup>122</sup> The same Dryer Fan Power formula as in the above footnote.



**WATER AND OTHER NON-ENERGY IMPACT DESCRIPTIONS AND CALCULATION**

N/A

**DEEMED O&M COST ADJUSTMENT CALCULATION**

N/A

**MEASURE CODE: CI-AGE-GDRY-V01-220101**

**REVIEW DEADLINE: 1/1/2025**

## 4.1.15 Grain Dryer Tune-Up

### DESCRIPTION

This measure is for commercial grain dryers for agricultural operations. Tune-ups improve grain drying efficiency by maintaining dryer components that have become clogged, dirty, or uncalibrated. This measure involves cleaning and/or inspecting burners, fans, and screens and cleaning and recalibrating all temperature and moisture sensors, if applicable.

Crops such as grain, soybeans, and corn need to be dried after harvest to prevent rot, mold, and animals from destroying the crop. After harvest, these wet crops are loaded into a grain dryer where they are dried. Grain drying processes vary but consist of warm (or high temperature) air forced through the crop. The air may be heated electrically or by fossil fuels. Once the grain is dried, it is stored in grain bins or silos until transport. At the time of harvest, moisture content inside grain varies between 17% and 40%. After drying, moisture levels are kept between 13% and 14% to improve shelf life. Maintaining peak efficiency of grain dryers through tune-ups is important for equipment efficiency and grain drying performance. Tune-ups save energy by removing impediments to airflow and calibrating sensors so that equipment capacity is maximized and drying time is minimized.

### DEFINITION OF EFFICIENT EQUIPMENT

To qualify for this measure, the facility must, as applicable, complete the tune-up requirements by an approved technician as specified below:

- Inspect and clean screens
- Inspect and clean fans
- Clean and calibrate all temperature sensors
- Clean and calibrate all moisture sensors\*
- Inspect and adjust grain dryer controls including temperature setpoint, as needed
- Lubricate bearings

Task marks with an asterisk (\*) are only required if the existing grain dryer contains this equipment.

### DEFINITION OF BASELINE EQUIPMENT

The baseline condition of this measure is a commercial-grade grain dryer that has not been tuned-up within the past 12 months.

### DEEMED LIFETIME OF EFFICIENT EQUIPMENT

The life of this measure is 1 year.<sup>123</sup>

### DEEMED MEASURE COST

The cost of this measure is \$500.00, which includes service and labor.<sup>124</sup>

### LOADSHAPE

N/A

---

<sup>123</sup> University of Wisconsin-Madison Extension. "Low Cost Energy Conservation: Grain Drying (A3784-10)." Tune-Ups are recommended annually because of the dusty environment components are subject to during the grain drying process. Although farms often defer grain dryer maintenance, the energy savings will not persist over multiple seasons.

<sup>124</sup> From Wisconsin Focus on Energy 2020 Technical Reference Manual, Grain Dryer Tune-Up (pg. 44). Incremental costs are based on trade ally survey.

**COINCIDENCE FACTOR**

N/A

---

**Algorithm**

---

**CALCULATION OF ENERGY SAVINGS**

**ELECTRIC ENERGY SAVINGS**

$$\Delta kWh = Bushels_{ANNUAL} * kWh\ Saved\ per\ Bushel$$

Where:

$Bushels_{ANNUAL}$  = Number of bushels of grain to be dried per year (bushels/yr)  
 = Custom

Where:

$$kWh\ Saved\ per\ Bushel = \left( GD_{EFF} * Lbs_{H2O\ REMOVED} * \frac{kWh\%}{3,412} \right) * SF$$

Where:

$kWh\ Saved\ per\ Bushel$  = Amount of energy saved per bushel of grain dried. Use actual if known. If unknown, default to calculated values in table below based on grain dryer type and efficiency.

$GD_{EFF}$  = Existing grain dryer efficiency (Btu/Lbs\_H2O)  
 = Custom, or default value in table below based on type of grain dryer

Grain Dryer Type	GD_EFF (Btu/Lbs_H2O) <sup>125</sup>	kWh% <sup>126</sup>	kWh Saved per Bushel	Therm Saved per Bushel
Low Temperature Bin Dryer	1,600	100%	0.11723	0
Continuous Mixed Flow Bin Dryer	2,000	2%	0.00293	0.00490
Mixed Flow Dryer	2,000	2%	0.00293	0.00490
High Temperature Batch Bin Dryer	2,400	2%	0.00352	0.00588
Continuous Cross-Flow (Tower) Dryer	2,400	2%	0.00352	0.00588
Cross-Flow Batch Dryer	2,500	2%	0.00366	0.00613

$$Lbs_{H2O\ REMOVED} = Grain_{LBS\ MOISTURE} * (\% Moisture_{IN} - \% Moisture_{OUT})$$

Where:

$Lbs_{H2O\ REMOVED}$  = Pounds of water removed per bushel

---

<sup>125</sup> U.S. Department of Agriculture. “Energy Self-Assessment, Step 2: Informational Section.” Grain Drying Energy Efficiency and Energy Cost graph. Accessed May 2019. See Grain Dryer Tune Up Supporting Document for referenced graph. And University of Wisconsin–Madison, Extension. Wisconsin Energy Efficiency and Renewable Energy “Improving Energy Efficiency in Grain Drying: Fact Sheet.” December 2012. **Error! Hyperlink reference not valid.**

<sup>126</sup> The National Corn Handbook. “Energy Conservation and Alternative Sources for Corn Drying.” NCH-14, page 3, Table 4.

= Default value in table or Custom calculation as detailed below

Crop Type	Moisture Removal Assumption	LBS_H2O Removed per Bushels <sub>annual</sub>
Corn	7% reduction (from 22% initial moisture content (MC) to 15% final MC) <sup>127</sup>	5.00
Soybean	7% reduction (from 20% initial MC to 13% final MC) <sup>128</sup>	5.04 <sup>129</sup>

$Grain_{LBS\ MOISTURE}$  = Lbs of moisture per bushel per 1% of moisture content reduction. Value is specific to grain type and is based on the following table: <sup>130</sup>

Grain Type	Lb Moisture/Bushel/1% Evaporation
Alfalfa	0.60 Lb Evap/Std Bu/Delta%
Barley	0.48 Lb Evap/Std Bu/Delta%
Clover	0.60 Lb Evap/Std Bu/Delta%
Corn, Shelled (15.5%)	0.56 Lb Evap/Std Bu/Delta%
Corn, Ear (15.5%)	0.68 Lb Evap/Std Bu/Delta%
Cotton	0.32 Lb Evap/Std Bu/Delta%
Cowpeas	0.60 Lb Evap/Std Bu/Delta%
Flax	0.60 Lb Evap/Std Bu/Delta%
Grass, Exc Timothy	0.14 Lb Evap/Std Bu/Delta%
Grass, Timothy	0.45 Lb Evap/Std Bu/Delta%
Lespedeza	0.45 Lb Evap/Std Bu/Delta%
Millet	0.80 Lb Evap/Std Bu/Delta%
Oats	0.32 Lb Evap/Std Bu/Delta%
Rape	0.60 Lb Evap/Std Bu/Delta%
Tye	0.56 Lb Evap/Std Bu/Delta%
Sorghum, Forage	0.50 Lb Evap/Std Bu/Delta%
Sorghum, grain (13.0%)	0.56 Lb Evap/Std Bu/Delta%
Soybeans	0.60 Lb Evap/Std Bu/Delta%
Sudan grass	0.28 Lb Evap/Std Bu/Delta%
Sunflower, oil type	0.28 Lb Evap/Std Bu/Delta%
Trefoil, Birdsfoot	0.60 Lb Evap/Std Bu/Delta%
Vetch	0.60 Lb Evap/Std Bu/Delta%
Wheat (13.5%)	0.60 Lb Evap/Std Bu/Delta%

$\% Moisture_{IN}$  = Average % moisture of grain as it arrives at the grain dryer

<sup>127</sup> The National Corn Handbook. “Energy Conservation and Alternative Sources for Corn Drying.” NCH-14, page 3, Table 4.

<sup>128</sup> University of Nebraska-Lincoln, Institute of Agriculture and Natural Resources. “Harvest Soybeans at 13% Moisture”.

<sup>129</sup> University of Minnesota Extension. “Storing, drying, and handling wet soybeans”. **Error! Hyperlink reference not valid.**

<sup>130</sup> “Tables for Weights and Measurement: Crops”. Murhpy, William J. Table shown was modified from the original by eliminating some redundant rows for similar crops, and by adding a new column that calculates pounds of moisture evaporated per standard bushel per 1% moisture reduction by the dryer.

- = Actual
- $\% Moisture_{OUT}$  = Average % moisture of grain as it exits the grain dryer after being dried
- = Actual
- $kWh\%$  = Percentage of overall dryer energy consumption that is electricity
- = Default value in table above based on type of grain dryer
- 3,412 = Conversion from Btu to kWh
- $SF$  = Savings factor
- = 5%<sup>131</sup>

**For example**, for a Mixed Flow Dryer that produces 100,000 bushels of corn per year.

$$\Delta Therms = 100,000 \frac{Bu}{yr} \times \left( 2,000 \frac{Btu}{lb H2O} \times 5.00 \frac{lbsH2O}{bu} \times \frac{98 \% Therm}{100,000 \frac{Btu}{Therm}} \right) \times 5\%$$

$$\Delta Therms = 490$$

**SUMMER COINCIDENT PEAK DEMAND SAVINGS**

N/A

**FOSSIL FUEL SAVINGS**

$$\Delta Therms = Bushels_{ANNUAL} * Therms Saved per Bushel$$

$$Therms Saved per Bushel = \left( GD_{EFF} * Lbs_{H2O REMOVED} * \frac{Therms\%}{100,000} \right) * SF$$

Where:

Therms Saved per Bushel = Amount of energy saved per bushel of grain dried. Use actual if known. If unknown, default to calculated values in table above based on grain dryer type and efficiency.

- Therms% = Percentage of overall dryer energy consumption that is natural gas
- = (1 – kWh%)
- 100,000 = Conversion factor
- $Lbs_{H2O REMOVED}$  =  $Grain_{LBS MOISTURE} * (\%Moisture_{IN} - \%Moisture_{OUT})$

**WATER AND OTHER NON-ENERGY IMPACT DESCRIPTIONS AND CALCULATION**

N/A

<sup>131</sup> Conservative estimate – assumptions outlined in the Wisconsin Focus on Energy 2020 Technical Reference Manual, Grain Dryer Tune-Up (pg. 44).

**DEEMED O&M COST ADJUSTMENT CALCULATION**

N/A

**MEASURE CODE: CI-AGE-DTUNE-V01-220101**

**REVIEW DEADLINE: 1/1/2025**

## 4.1.16 Greenhouse Boiler Tune-Up

### DESCRIPTION

This measure is for a non-residential greenhouse boiler. For space heating other than greenhouses, see measure 4.4.2 Space Heating Boiler Tune-Up. For process heating other than greenhouses, see measure 4.4.3 Process Boiler Tune-Up. The tune-up will improve boiler efficiency by cleaning and/or inspecting burners, combustion chamber, and burner nozzles. Adjust air flow and reduce excessive stack temperatures, adjust burner and gas input. Check venting, safety controls, and adequacy of combustion air intake. Combustion efficiency should be measured before and after tune-up using an electronic flue gas analyzer.

### DEFINITION OF EFFICIENT EQUIPMENT

To qualify for this measure the facility must, as applicable, complete the tune-up requirements by approved technician<sup>132</sup> as specified below:

- Measure combustion efficiency using an electronic flue gas analyzer
- Adjust airflow and reduce excessive stack temperatures
- Adjust burner and gas input, manual or motorized draft control
- Check for proper venting
- Complete visual inspection of system piping and insulation
- Check safety controls
- Check adequacy of combustion air intake
- Clean fireside surfaces
- Inspect all refractory. Patch and wash coat as required.\*
- Inspect gaskets on front and rear doors and replace as necessary.\*
- Seal and close front and rear doors properly.\*
- Clean low and auxiliary low water cut-off controls, then re-install using new gaskets.\*
- Clean plugs in control piping.\*
- Remove all hand hole and man hole plates. Flush boiler with water to remove loose scale and sediment.\*
- Replace all hand hole and man hole plates with new gaskets.\*
- Open feedwater tank manway, inspect and clean as required. Replace manway plate with new gasket.\*
- Clean burner and burner pilot.
- Check pilot electrode and adjust or replace.
- Clean air damper and blower assembly.
- Clean motor starter contacts and check operation.\*
- Make necessary adjustments to burner for proper combustion.
- Perform all flame safeguard and safety trip checks.
- Check all hand hole plates and man hole plates for leaks at normal operating temperatures and pressures.
- Troubleshoot any boiler system problems as requested by on-site personnel

Note: Tune-up activities marked with an asterisk (\*) are eligible to be performed by internal maintenance staff at periods of boiler shutdown.

### DEFINITION OF BASELINE EQUIPMENT

The baseline condition of this measure is a boiler that has not had a tune-up within the past 36 months.

### DEEMED LIFETIME OF EFFICIENT EQUIPMENT

The life of this measure is 3 years.<sup>133</sup>

---

<sup>132</sup> Act on Energy Commercial Technical Reference Manual No. 2010-4, 9.2.2 Gas Boiler Tune-up

<sup>133</sup> Act on Energy Commercial Technical Reference Manual No. 2010-4, 9.2.2 Gas Boiler Tune-up

**DEEMED MEASURE COST**

The cost of this measure is \$0.83/MBtu/hr per tune-up.<sup>134</sup>

**DEEMED O&M COST ADJUSTMENTS**

N/A

**LOADSHAPE**

N/A

**COINCIDENCE FACTOR**

N/A

---



---

**Algorithm**

---



---

**CALCULATION OF ENERGY SAVINGS**

**ELECTRIC ENERGY SAVINGS**

N/A

**SUMMER COINCIDENT PEAK DEMAND SAVINGS**

N/A

**FOSSIL FUEL SAVINGS**

$$\Delta\text{Therms} = ((\text{Capacity} * 8766 * \text{UF}) / 100) * (1 - (\text{Eff}_{\text{pre}} / \text{Eff}_{\text{measured}}))$$

Where:

Capacity = Boiler gas input size (kBtu/hr)  
 = Custom

UF = Utilization Factor  
 = Default Utilization Factor for heating in a greenhouse for agricultural end use are listed in the table below, or use a custom value based on modeling.<sup>135,136</sup>

Building Type	Heating UF Existing Buildings					Model Source
	Zone 1 (Rockford)	Zone 2 (Chicago)	Zone 3 (Springfield)	Zone 4 (Belleville)	Zone 5 (Marion)	
Greenhouses with curtains	0.473	0.445	0.383	0.328	0.321	Virtual Grower 3.1, with ASHRAE HDD
Greenhouses without curtains	0.476	0.447	0.385	0.330	0.323	Virtual Grower 3.1, with ASHRAE HDD

<sup>134</sup> Work Paper – Tune up for Boilers serving Space Heating and Process Load by Resource Solutions Group, January 2012

<sup>135</sup> Custom site-specific utilization factors for greenhouses can be modeled using the greenhouse configuration and boiler capacity with USDA Virtual Grower software. <https://www.ars.usda.gov/midwest-area/wooster-oh/application-technology-research/docs/virtual-grower/>

<sup>136</sup> ASHRAE Fundamentals 2017 Chapter 14 Appendix HDD at 65 °F was used to smooth the Virtual Grower software outputs.



Eff<sub>pre</sub> = Boiler Combustion Efficiency Before Tune-Up  
 = Actual. Default value is 80.3%<sup>137</sup>

*Note: Contractors should select a firing rate that appropriately represents the average operating condition and take readings at a consistent firing rate for pre and post tune-up.*

Eff<sub>measured</sub> = Boiler Combustion Efficiency after Tune-Up  
 = Actual. Default value is 82.6%<sup>138</sup>

100 = Conversion from kBtu to therms

8766 = Hours per year

**For example**, a greenhouse 80.3% efficient, 1050 kBtu boiler is tuned-up resulting in final efficiency of 82.6%:

$$\Delta \text{therms} = ((1050 * 8766 * 0.419) / 100) * (1 - (0.803 / 0.826))$$

$$= 1074 \text{ therms}$$

**WATER AND OTHER NON-ENERGY IMPACT DESCRIPTIONS AND CALCULATION**

N/A

**DEEMED O&M COST ADJUSTMENT CALCULATION**

N/A

**MEASURE CODE: CI-AGE-GTUNE-V01-220101**

**REVIEW DEADLINE: 1/1/2025**

---

<sup>137</sup> Guidehouse evaluation results from tune-up efficiency improvement research for Peoples Gas and North Shore Gas through their C&I and Public Sector Prescriptive Rebate Program, their Small Business Program, and their Multi-Family Programs. The evaluation included project and population data from program year’s 2018 and 2019.

<sup>138</sup> Guidehouse evaluation results from tune-up efficiency improvement research for Peoples Gas and North Shore Gas through their C&I and Public Sector Prescriptive Rebate Program, their Small Business Program, and their Multi-Family Programs. The evaluation included project and population data from program year’s 2018 and 2019.

#### 4.1.17 Greenhouse Thermal Curtains

##### DESCRIPTION

Existing greenhouse construction with polyethylene (PE) roofs allows for significant heat loss overnight. The existing PE roofs cause radiant heat to enter the space during daytime, but also lead to heat loss to outside the structure during the night. This can be addressed using thermal curtains which decrease conduction, convection, and radiation heat losses in greenhouses. Thermal curtains are installed inside the greenhouse and are designed to be placed horizontally above the growing zone within a greenhouse. In addition to retaining heat, thermal curtains are commonly used for shading. Thermal insulating curtains are sheets of fabric that extend above the plant growing zone and span the length of the greenhouse. These curtain barriers can reduce nighttime heat loss by more than 20%.<sup>139</sup> Operation of thermal curtains can be manual or motorized, but must be installed to ensure a tight seal at all connection points.

This measure case is defined as the installation of a single-layer heat curtain with infrared film in a greenhouse area in which a heat curtain was not present. It is assumed that the thermal curtains are deployed during nighttime hours, and open during daytime hours. This measure was developed to be applicable to the following program types: NC, RF. If applied to other program types, the measure savings should be verified.

##### DEFINITION OF EFFICIENT EQUIPMENT

This measure case is defined as the installation of a single-layer heat curtain with infrared film in a greenhouse area in which a heat curtain was not present. It is assumed that the thermal curtains are deployed during nighttime hours, and open during daytime hours. They can either be manual or motorized thermal curtains installed in greenhouse constructed of PE glazing.

##### DEFINITION OF BASELINE EQUIPMENT

The baseline equipment is a greenhouse constructed of PE glazing and no thermal curtain.

##### DEEMED LIFETIME OF EFFICIENT EQUIPMENT

The measure lifetime for greenhouse thermal curtains is 5 years.<sup>140</sup>

##### DEEMED MEASURE COST

Measure cost for greenhouse thermal curtains is \$1.50 per square foot.<sup>141</sup>

##### LOADSHAPE

NA

##### COINCIDENCE FACTOR

NA

---



---

#### Algorithm

---



---

##### CALCULATION OF ENERGY SAVINGS

Energy savings are estimated using EnergyPlus version 9.4 whole-building energy simulation. The greenhouse geometry used in the EnergyPlus model consists of 4 connected bays, each bay with a gable type roof construction, measuring 36 feet wide by 100 feet long. The total conditioned floor area of the modeled greenhouse is 14,210

---

<sup>139</sup> Sanford, Scott, College of Agricultural and Life Science, University of Wisconsin Cooperative Extension. *Using Greenhouse Curtains to Reduce Greenhouse Heating and Cooling Costs*.

<sup>140</sup> DEER 2008, <http://www.deeresources.com/>

<sup>141</sup> 'Greenhouse Thermal Curtains', Pacific Gas & Electric Company, PGECOAGR101, 2008

square feet, and savings are normalized per square foot floor area. The greenhouse is conditioned by gas-fired unit heaters and no cooling system. Greenhouse thermal curtain U values vary depending on the material type like spunbonded polyester, double-knit cloth, aluminized vinyl, aluminum strips, etc. They can have U values as low as 0.26 up to as high as 0.77. However, an average case of 0.483 U value has been simulated here which is assumed to represent a majority of thermal curtains.<sup>142</sup> The area of the thermal curtain equals the conditioned floor area of the greenhouse.

Baseline and efficient models were developed for each Illinois climate zone using inputs for key greenhouse construction characteristics and sources as listed in the following table:

Retrofit:

Input Parameter	Baseline Value	Efficient Value
Roof Glazing	Double PE film, U-value 0.7 (Btu/h · ft <sup>2</sup> · °F) <sup>143</sup>	Same as baseline.
Thermal Curtain	None.	Sunset - Sunrise, U-value 0.483 (Btu/h · ft <sup>2</sup> · °F) <sup>144</sup>
Wall Glazing	Single PE film, U-value 1.1 (Btu/h · ft <sup>2</sup> · °F) <sup>145</sup>	Same as baseline.
Infiltration	1.5 Air Change per Hour (ACH) <sup>146</sup>	Same as baseline.
Ventilation	10 cubic feet per minute (CFM) per area (ft <sup>2</sup> ) <sup>147</sup>	Same as baseline.
Heating System	Gas-fired unit heater, 0.8 efficiency	Same as baseline.
Thermostat Setpoint	Heating setpoint 70°F	Same as baseline.
Cooling System	Natural Ventilation	Same as baseline.
Occupancy Schedule	8am – 4pm	Same as baseline.
Lighting Power Density	1.83 watts per square foot <sup>148</sup>	Same as baseline.
Lighting Schedule	Varies monthly based on available daylight hours, supplemental lighting operates between 5 – 11 hours per day to target 20 total light hours. <sup>149</sup>	Same as baseline.

New Construction:<sup>150</sup>

<sup>142</sup> Bartok, John, Department of Natural Resources Management and Engineering, University of Connecticut, Natural Resource, Agriculture, and Engineering Service (NRAES) Cooperative Extension, Energy Conservation for Commercial Greenhouses, 2001 Revision, Table 4-1 Heat loss through blanket and roof, average of all material types.

<sup>143</sup> Bartok, Table 1-2 Heat flow u-value for double layer polyethylene film.

<sup>144</sup> Bartok, Table 4-1 Heat loss through blanket and roof, average of all material types.

<sup>145</sup> Bartok, Table 1-2 Heat flow u-value for single layer polyethylene film.

<sup>146</sup> ASHRAE HVAC Applications, Design for Greenhouses, ch. 25.2.1 Table 4, Suggested Design Air Changes for old construction with good maintenance.

<sup>147</sup> Bartok, Chapter 6, page 42.

<sup>148</sup> ASHRAE ch. 25.2.2 Table 10, Suggested Radiant Energy, Duration, and Time of Day for Supplemental Lighting in Greenhouses, average of all W/ft<sup>2</sup>.

<sup>149</sup> ASHRAE ch. 25.2.2 Table 10, Suggested Radiant Energy, Duration, and Time of Day for Supplemental Lighting in Greenhouses, average of all hours.

<sup>150</sup> New construction greenhouses are compliant with IECC 2021 thermal envelope requirements. As code requirements and adoption can differ from municipality to municipality, the user should verify which version of code is applicable given these constraints.

Input Parameter	Baseline Value	Efficient Value
Roof Glazing	Double PE film, U-value 0.5 (Btu/h · ft <sup>2</sup> · °F)	Same as baseline.
Thermal Curtain	None.	Sunset - Sunrise, U-value 0.483 (Btu/h · ft <sup>2</sup> · °F)
Wall Glazing	Double PE film, U-value 0.7(Btu/h · ft <sup>2</sup> · °F)	Same as baseline.
Infiltration	1.5 Air Changes per Hour (ACH)	Same as baseline.
Ventilation	10 cubic feet per minute (CFM) per area (ft <sup>2</sup> )	Same as baseline.
Heating System	Gas-fired unit heater, 0.8 efficiency	Same as baseline.
Thermostat Setpoint	Heating setpoint 70°F	Same as baseline.
Cooling System	Natural Ventilation	Same as baseline.
Occupancy Schedule	8am – 4pm	Same as baseline.
Lighting Power Density	1.83 watts per square foot	Same as baseline.
Lighting Schedule	Varies monthly based on available daylight hours, supplemental lighting operates between 5 – 11 hours per day to target 20 total light hours.	Same as baseline.

**ELECTRIC ENERGY SAVINGS**

NA

**SUMMER COINCIDENT PEAK DEMAND SAVINGS**

NA

**FOSSIL FUEL SAVINGS**

Natural gas savings are presented for each climate zone per square foot of greenhouse floor area, which constitutes all floor space under the thermal curtains, including pathways and growing canopy.

Zone	Retrofit Therm Savings per Square Foot	NC Therm Savings per Square Foot
Rockford	0.394	0.275
Chicago	0.361	0.250
Springfield	0.325	0.226
Belleville	0.317	0.222
Marion	0.265	0.191

**Example:**

An existing 15,000 sq.ft greenhouse located in Chicago is retrofitting a thermal curtain with an IR film above the growing zone. The annual savings for the installation will be computed as:

Savings = 15,000 \* 0.361 = 5,415 therms.

**WATER AND OTHER NON-ENERGY IMPACT DESCRIPTIONS AND CALCULATION**

NA

**DEEMED O&M COST ADJUSTMENT CALCULATION**

NA

**MEASURE CODE: CI-AGE-GHEAT-V02-230101**

**REVIEW DEADLINE: 1/1/2025**

## 4.1.18 Infrared Film for Greenhouse

### DESCRIPTION

Existing greenhouse construction with polyethylene (PE) roofs allows for heat transmission loss up to 50%<sup>151</sup>. The existing PE roofs cause radiant heat to enter the space during daytime, but also lead to heat loss to the outside during the night. This issue can be addressed using Infrared-treated (IR) films. They can be applied on the interior side of the PE roof, reducing heat loss through the roof overnight by absorbing and re-emitting infrared radiation and can reduce heat loss by up to 20%.<sup>152</sup> Reduction in heat loss through the roof overnight reduces the heating load on the greenhouse heating system. This measure applies to greenhouses with polyethylene roof construction.

This measure case is defined as a greenhouse roof with infrared (IR) inhibiting film additive on the inflated double polyethylene roof. This measure was developed to be applicable to the following program types: NC, RF. If applied to other program types, the measure savings should be verified.

### DEFINITION OF EFFICIENT EQUIPMENT

The efficient equipment is infrared film installed on the interior of a PE roof glazing in a gas-heated greenhouse. The recommendation is to use one layer of IR film placed as the inner layer of the roof glazing. Doing this allows the wetting agent that is also included in most films to conduct the condensed moisture away.

### DEFINITION OF BASELINE EQUIPMENT

The baseline equipment is a gas-heated greenhouse with PE roof glazing construction and no infrared film.

### DEEMED LIFETIME OF EFFICIENT EQUIPMENT

The measure lifetime for infrared film is 5 years.<sup>153</sup>

### DEEMED MEASURE COST

Incremental cost for IR films installed in new/retrofit applications is \$0.02 per square foot of IR film.<sup>154</sup>

### LOADSHAPE

NA

### COINCIDENCE FACTOR

NA

---



---

### Algorithm

---



---

### CALCULATION OF ENERGY SAVINGS

Energy savings are estimated using EnergyPlus version 9.4 whole-building energy simulation. The greenhouse geometry used in the EnergyPlus model consists of 4 connected bays, each bay with a gable type roof construction, measuring 36 feet wide by 100 feet long. The total conditioned floor area of the modeled greenhouse is 14,210 square feet, and savings are normalized per square foot of conditioned floor area. The greenhouse is conditioned by

---

<sup>151</sup> Bartok, John, Department of Natural Resources Management and Engineering, University of Connecticut, Natural Resource, Agriculture, and Engineering Service (NRAES) Cooperative Extension, *Energy Conservation for Commercial Greenhouses*, 2001 Revision, Chapter 1, page 4.

<sup>152</sup> Bartok, Chapter 1, page 5.

<sup>153</sup> Itron, Inc. 2005. *2004-2005 Database for Energy Efficiency Resources (DEER) Update Study – Final Report*. Prepared for Southern California Edison.

<sup>154</sup> Itron, Inc. 2014. *2010-2012 W0017 Ex Ante Measure Cost Study Final Report*. Prepared for the California Public Utilities Commission.

gas-fired unit heaters and has no dedicated cooling system. Cooling is typically achieved by natural ventilation and exhaust/ventilations fans in the greenhouse space.

Baseline and efficient models were developed for each Illinois climate zone using inputs for key greenhouse construction characteristics and sources as listed in the following table:

Retrofit:

Input Parameter	Baseline Value	Efficient Value
Roof Glazing	Double PE film, U-value 0.7 (Btu/h · ft <sup>2</sup> · °F) <sup>155</sup>	IR-treated double PE film, U-value 0.5 (Btu/h · ft <sup>2</sup> · °F) <sup>156</sup>
Wall Glazing	Single PE film, U-value 1.1 (Btu/h · ft <sup>2</sup> · °F) <sup>157</sup>	Same as baseline.
Infiltration	1.5 Air Change per Hour (ACH) <sup>158</sup>	Same as baseline.
Ventilation	10 cubic feet per minute (CFM) per area (ft <sup>2</sup> ) <sup>159</sup>	Same as baseline.
Heating System	Gas-fired unit heater, 0.8 efficiency	Same as baseline.
Thermostat Setpoint	Heating setpoint 70°F	Same as baseline.
Cooling System	Natural Ventilation	Same as baseline.
Occupancy Schedule	8am – 4pm	Same as baseline.
Lighting Power Density	1.83 watts per square foot <sup>160</sup>	Same as baseline.
Lighting Schedule	Varies monthly based on available daylight hours, supplemental lighting operates between 5 – 11 hours per day to target 20 total light hours. <sup>161</sup>	Same as baseline.

New Construction:<sup>162</sup>

Input Parameter	Baseline Value	Efficient Value
Roof Glazing	Double PE film, U-value 0.5 (Btu/h · ft <sup>2</sup> · °F)	IR-treated double PE film, U-value 0.3 (Btu/h · ft <sup>2</sup> · °F)
Wall Glazing	Double PE film, U-value 0.7 (Btu/h · ft <sup>2</sup> · °F)	Same as baseline.
Infiltration	1.5 Air Change per Hour (ACH)	Same as baseline.

<sup>155</sup> Bartok, Table 1-2 Heat flow u-value for double layer polyethylene film.

<sup>156</sup> Bartok, Table 1-2 Heat flow u-value for IR-inhibited double layer polyethylene film.

<sup>157</sup> Bartok, Table 1-2 Heat flow u-value for single layer polyethylene film.

<sup>158</sup> ASHRAE HVAC Applications, Design for Greenhouses, ch. 25.2.1 Table 4, Suggested Design Air Changes for old construction with good maintenance.

<sup>159</sup> Bartok, Chapter 6, page 42.

<sup>160</sup> ASHRAE ch. 25.2.2 Table 10, Suggested Radiant Energy, Duration, and Time of Day for Supplemental Lighting in Greenhouses, average of all W/ft<sup>2</sup>.

<sup>161</sup> ASHRAE ch. 25.2.2 Table 10, Suggested Radiant Energy, Duration, and Time of Day for Supplemental Lighting in Greenhouses, average of all hours.

<sup>162</sup> New construction greenhouses are compliant with IECC 2021 thermal envelope requirements. As code requirements and adoption can differ from municipality to municipality, the user should verify which version of code is applicable given these constraints.

Input Parameter	Baseline Value	Efficient Value
Ventilation	10 cubic feet per minute (CFM) per area (ft <sup>2</sup> )	Same as baseline.
Heating System	Gas-fired unit heater, 0.8 efficiency	Same as baseline.
Thermostat Setpoint	Heating setpoint 70°F	Same as baseline.
Cooling System	Natural Ventilation	Same as baseline.
Occupancy Schedule	8am – 4pm	Same as baseline.
Lighting Power Density	1.83 watts per square foot	Same as baseline.
Lighting Schedule	Varies monthly based on available daylight hours, supplemental lighting operates between 5 – 11 hours per day to target 20 total light hours.	Same as baseline.

**ELECTRIC ENERGY SAVINGS**

NA

**SUMMER COINCIDENT PEAK DEMAND SAVINGS**

NA

**FOSSIL FUEL SAVINGS**

Natural gas savings are presented for each climate zone per square foot of greenhouse floor area, which constitutes all floor space under the thermal curtains, including pathways and growing canopy.

Zone	Retrofit Therm Savings per Square Foot of Floor Area	NC Therms Savings per Square Foot of Floor Area
Rockford	0.256	0.314
Chicago	0.232	0.285
Springfield	0.206	0.253
Belleville	0.198	0.245
Marion	0.163	0.212

For example:

A 15,000 sq.ft greenhouse located in Chicago is retrofitting its roof glazing material with an infrared film. The annual savings for the installation will be computed as:

$$\text{Savings} = 15,000 * 0.232 = 3,480 \text{ therms.}$$

**WATER AND OTHER NON-ENERGY IMPACT DESCRIPTIONS AND CALCULATION**

NA

**DEEMED O&M COST ADJUSTMENT CALCULATION**

NA



**MEASURE CODE: CI-AGE-GFILM-V02-230101**

**REVIEW DEADLINE: 1/1/2025**

### 4.1.19 ENERGY STAR Dairy Water Heater

#### DESCRIPTION

This measure is for upgrading from federal minimum code efficiency to an ENERGY STAR commercial or residential high efficiency water heater on a dairy farm. Water heaters may have a tank for water storage or may be instantaneous. For electric water heaters to be certified by ENERGY STAR, heat pump technology is required. Energy performance of residential water heaters is typically measured by Uniform Energy Factor (UEF) [large sizes are measured by Energy Factor (EF)], gas commercial water heaters are rated by Thermal Efficiency ( $E_t$ ), and electric commercial water heaters are rated by Coefficient of Performance (COP).

#### DEFINITION OF EFFICIENT EQUIPMENT

The high efficiency equipment must meet ENERGY STAR specifications.<sup>163</sup>

#### DEFINITION OF BASELINE EQUIPMENT

Time of sale: The baseline condition is assumed to be a new standard water heater of the same type and service (residential, commercial) as the existing unit being replaced. The new equipment must exceed federal standard efficiency based on equipment type, size category, and subcategory/rating condition.

New Construction: The baseline condition is a new standard water heater of the same type as the efficient, meeting the IECC code level in place at the time the building permit was issued. As code requirements and adoption can differ from municipality to municipality, the user should verify which version of code is applicable given these constraints. Note, IECC 2021 is expected to become effective statewide on in the fall of 2023. IECC 2018 is the requisite code for any projects with permitting dates spanning July 1, 2019 to October 1, 2022. Prior to July 1, 2019, IECC 2015 is the applicable code

For dairies, efficiency requirements assume a high draw pattern.

Service Type	Equipment Type	Size Category	Federal Minimum Efficiency Requirements <sup>164</sup>
Residential	Gas-Fired Storage Water Heater ≤75,000 Btu/h	≥20 gal and ≤55 gal	$UEF = 0.6920 - 0.0013 \times V_r$
		>55 gal and ≤100 gal	$UEF = 0.8072 - 0.0003 \times V_r$
		> 100 gal	$EF = 0.6200 - 0.0019 \times V_r$
	Gas Fired Instantaneous Water Heater	< 2 gal and > 50,000 Btu/h	$UEF = 0.81$
	Electric Storage Water Heater	≥20 gal and ≤55 gal	$UEF = 0.9349 - 0.0001 \times V_r$
		>55 gal and ≤120 gal	$UEF = 2.2418 - 0.0011 \times V_r$
> 120 gal		$EF = 0.9300 - 0.00132 \times V_r$	
Residential-duty Commercial	High Capacity Storage Gas-Fired Storage Water Heaters > 75,000 Btu/h	≤120 gallon tanks	$UEF = 0.6597 - (0.0009 * V_r$
Commercial	Gas Storage	Any	80% $E_t$
	Gas Instantaneous	Any	80% $E_t$
	Electric Storage	Any	2.18 COP

<sup>163</sup> ENERGY STAR Program Requirements for Product Specification for Residential Water Heaters, v4.0, effective January 5, 2022. ENERGY STAR Program Requirements Product Specification for Commercial Water Heaters, v2.0, effective October 1, 2018.

<sup>164</sup> Minimum performance rating assumes a high usage draw pattern of 84 gallons per day. A typical dairy in Illinois is estimated to use 131.7 gallons of hot water per day. Please see '4.1.10 Dairy Refrigeration Heat Recovery' for the derivation of the hot water heated on an average dairy farm. Note that minimum performance requirements for residential water heaters toggle

**DEEMED LIFETIME OF EFFICIENT EQUIPMENT**

The expected measure life is assumed to be 15 years for storage units, 20 years for tankless water heaters.<sup>165</sup>

**DEEMED MEASURE COST**

The full install cost and incremental cost assumptions are provided below.<sup>166</sup> Actual costs should be used where available:

Equipment Type	Category	Installed Cost	Incremental Cost
Gas Storage Water Heaters ≥ 75,000 Btu/hr, ≤55 gallons	Baseline	\$616	N/A
	Efficient	\$1,055	\$440
Gas Storage Water Heaters > 75,000 Btuh/h	80% E <sub>t</sub>	\$4,886	N/A
	83% E <sub>t</sub>	\$5,106	\$220
	84% E <sub>t</sub>	\$5,299	\$413
	85% E <sub>t</sub>	\$5,415	\$529
	86% E <sub>t</sub>	\$5,532	\$646
	87% E <sub>t</sub>	\$5,648	\$762
	88% E <sub>t</sub>	\$5,765	\$879
	89% E <sub>t</sub>	\$5,882	\$996
Electric Storage Water Heaters	90% E <sub>t</sub>	\$6,021	\$1,135
	50 gallons		\$1,050
	80 gallons		\$1,050
	100 gallons		\$1,950

**LOADSHAPE**

For electric hot water heaters, use Loadshape C02 – Commercial Electric DHW.

**COINCIDENCE FACTOR**

The coincidence factor is assumed to be 0.925.<sup>167</sup>

---

**Algorithm**

---

between EF and UEF depending on size category based on ‘Code of Federal Regulations, federal standards for residential water heaters, 10 CFR 432.32(d)’. Commercial water heaters must meet a minimum Thermal Efficiency (TE) and are subject to maximum standby loss requirements of  $Q/800 + 110 \times \sqrt{V_r}$ , where Q is the input rating in Btu/hr per ‘2019 Building Energy Efficiency Standards; 5.3 Mandatory Requirements for Water Heating’, California Energy Commission.

<sup>165</sup> Additional reference stating >20 years from the US DOE Energy Savers for Tankless or Demand-Type Water Heaters, and 15 years from the ‘New York Standard Approach for Estimating Energy Savings from Energy Efficiency Programs’, v8.0, effective January 1, 2021.

<sup>166</sup> From the 2010-2012 WO017 Ex Ante Measure Cost Study Final Report from the California Public Utilities Commission Table 3-12.

<sup>167</sup> Coincidence factor based on the average wattage in peak period divided by the maximum wattage from Itron eShape data for Missouri, calibrated to Illinois loads.

## CALCULATION OF ENERGY SAVINGS

### ELECTRIC ENERGY SAVINGS

Electric energy savings are calculated for electric water heaters per the equations given below.

$$\Delta kWh = \frac{(T_{OUT} - T_{IN}) * HotWaterUse_{Gallon} * \gamma_{Water} * 1 * \left( \frac{1}{UEF_{elecbase}} - \frac{1}{UEF_{Eff}} \right)}{3412}$$

Where:

$T_{OUT}$	= Tank Temperature = 170°F <sup>168</sup>
$T_{IN}$	= Incoming water temperature from well or municipal system or other <sup>169</sup> = Take measurement if possible, otherwise use the following assumptions. = 52.3°F, average well water temperature if no Dairy Refrigeration Heat Recovery system installed = 120°F, if Dairy Refrigeration Heat Recovery system is operational = 86°F, if unknown <sup>170</sup>
HotWaterUse <sub>Gallon</sub>	= Estimated annual hot water consumption (gallons) = Actual if possible to provide reasonable custom estimate. If not, use the following formula: = GPD * 365  GPD = average gallons of hot water usage per day (=1.30 gallons per cow per day <sup>171</sup> ) * Number of Milking Cows being served by the water heater
$\gamma_{Water}$	= Density of Water (lb/gal) = 8.33 lbs/gal
1	= Specific Heat of Water (Btu/lb°F)
UEF <sub>elecbase</sub>	= Rated efficiency of baseline water heater expressed as Uniform Energy Factor (UEF)
UEF <sub>eff</sub>	= Rated efficiency of the efficient water heater expressed as Uniform Energy Factor (UEF) = Actual per ENERGY STAR certified equipment product list
3412	= Converts Btu to kWh

<sup>168</sup> Water heating temperature for dairy farms: The cycle for cleaning needs 170 °F to start and cannot drop below 120°F by the end of the wash cycle. ‘Hot Water for Dairy Farms’, PHCP Pros, Harvey Ramer, May 11, 2017

<sup>169</sup> Expected temperature a refrigeration heat recovery unit can pre-heat well water up to. For more detail, please see: ‘4.1.10 Dairy Refrigeration Heat Recovery.’

<sup>170</sup> Average value assuming 50% of farms have Dairy Refrigeration Heat Recovery system

<sup>171</sup> ‘4.1.10 Dairy Refrigeration Heat Recovery’ details average default values for hot water use and number of milking cows if unknown. The 1.30 gallons of hot water per day is calculated from (131.7 GPD/101 cows). This value is corroborated by milking system washing hot water consumption of 5L per cow (1.32 gallons per cow) per Shortall J. et al. and supported by data from NYSERDA Dairy Farm Audit Summary, in which 10 dairy farms averaged of 1.40 gallons of hot water per cow per day based on measured electric water heater energy consumption and assumed 98% efficiency.

**SUMMER COINCIDENT PEAK DEMAND SAVINGS**

$$\Delta kW = \frac{\Delta kWh}{Hours} * CF$$

Where:

- Hours = Full load hours of water heater<sup>172</sup>  
= 6,461
- CF = Summer Peak Coincidence Factor for measure  
= 0.925<sup>173</sup>

**For example**, a residential ENERGY STAR water heater of 100 gallons rated capacity and UEF of 3.5 will be serving hot water to 101 cows milked daily. The farm does not currently have any dairy refrigeration heat recovery system so they are directly getting the water from a well and heating it to 170°F to clean the milking equipment.

$$\Delta kWh = \frac{(T_{OUT} - T_{IN}) * HotWaterUse_{Gallon} * \gamma_{Water} * 1 * \left( \frac{1}{UEF_{elecbase}} - \frac{1}{UEF_{Eff}} \right)}{3,412}$$

$$\Delta kWh = \frac{(170 \text{ }^\circ\text{F} - 52.3 \text{ }^\circ\text{F}) * 101 \text{ cows} * \frac{1.30 \text{ gal}}{\text{cow day}} * 8.33 \frac{\text{lb}}{\text{gal}} * 1 \frac{\text{Btu}}{\text{lb}^\circ\text{F}} * \left( \frac{1}{(2.2418 - 0.0011 \times 100)} - \frac{1}{3.5} \right)}{3,412 \frac{\text{Btu}}{\text{kWh}}}$$

$$* 365 \frac{\text{days}}{\text{yr}}$$

$$= 2,527 \text{ kWh}$$

For Demand Saving:

$$\Delta kW = \frac{\Delta kWh}{Hours} * CF$$

$$\Delta kW = \frac{2,527}{6,461} * 0.925 = 0.36 \text{ kW}$$

**FOSSIL FUEL SAVINGS**

Natural gas energy savings are calculated for natural gas storage water heaters per the quations given below.

$$\Delta Therms = \frac{(T_{out} - T_{in}) * HotWaterUse_{Gallon} * \gamma_{Water} * 1 * \left( \frac{1}{UEF_{gasbase}} - \frac{1}{UEF_{Eff}} \right)}{100,000}$$

Where:

- 100,000 = Converts Btu to Therms

<sup>172</sup> Full load hours assumption based on Wh/Max W Ratio from Itron eShape data for Missouri, calibrated to Illinois loads.

<sup>173</sup> Coincidence factor based on Average W in peak period/Max W from Itron eShape data for Missouri, calibrated to Illinois loads.

$UEF_{gasbase}$  = Rated efficiency of baseline water heater (Expressed as Uniform Energy Factor (UEF)).

**For example**, a 150,000 Btu/h gas storage water heater of 100 gallons rated volume and UEF of 0.9 delivers hot water for 101 cows milked daily. The farm has a dairy refrigeration heat recovery system that supplies 120 °F water to the heater. The farm uses 170°F hot water for milking equipment cleaning.

$$\Delta Therms = \frac{(T_{OUT} - T_{IN}) \times HotWaterUse_{Gallon} \times \gamma_{Water}}{100,000 \frac{Btu}{therm}} \times 1 \times \left( \frac{1}{UEF_{gasbase}} - \frac{1}{UEF_{Eff}} \right)$$

$$\Delta Therms = \frac{(170 - 120)^{\circ}F \times 101 \text{ cows} \times \frac{1.30 \text{ gal}}{\text{day}} \times 365 \frac{\text{days}}{\text{yr}} \times 8.33 \frac{\text{lb}}{\text{gal}}}{100,000 \frac{Btu}{Therm}} \times 1 \frac{Btu}{\text{lb}^{\circ}F} \times \left( \frac{1}{0.8072 - 0.0003 \times 100} - \frac{1}{0.9} \right) \times 365 \frac{\text{Days}}{\text{yr}}$$

$$\Delta Therms = 35 \text{ Therms}$$

**WATER AND OTHER NON-ENERGY IMPACT DESCRIPTIONS AND CALCULATION**

N/A

**DEEMED O&M COST ADJUSTMENT CALCULATION**

N/A

**MEASURE CODE: CI-AGE-ESWH-V03-240101**

**REVIEW DEADLINE: 1/1/2025**

## 4.1.20 Commercial Electric Lawn Mower

### DESCRIPTION

This measure identifies the claimed savings associated with commercial lawn mower electrification. This measure was developed to be applicable to the following program types: TOS.

Time of Sale (TOS):

- The use of all-electric equipment in place of a device with a spark-ignition gasoline-powered engine.
- Note that the baseline in this case is an equivalent replacement system to that which exists currently in the business.

If applied to other program types, the measure savings should be verified.

### DEFINITION OF EFFICIENT EQUIPMENT

The efficient condition is an all-electric lawn mower sized to be equivalent to the baseline gasoline-powered mower.

### DEFINITION OF BASELINE EQUIPMENT

The baseline condition is a new gasoline-powered lawn mower.

### DEEMED LIFETIME OF EFFICIENT EQUIPMENT

The expected measure life varies based on the equipment type (displayed in the table below).

Equipment Type	Measure Life (years) <sup>174</sup>
Riding Lawn Mower	10
Push Lawn Mower	10

### DEEMED MEASURE COST

For Time of Sale (TOS) the incremental cost should be used. Actual costs can also be used although care should be taken as costs can vary significantly. Defaults are provided below.

Equipment Type	Incremental Cost <sup>175</sup>
Riding Lawn Mower	\$21,373
Push Lawn Mower	\$500

### LOADSHAPE

Loadshape C03 – Commercial Cooling<sup>176</sup>

<sup>174</sup> Conservative estimate given lack of definitive source. Useful life for commercial gasoline-powered mowers is 5 years, per CARB (2022). CCI Emission Factor Database, “Fuel-Specific GHG” worksheet, available at [cci\\_emissionfactordatabase\\_2022-11-30.xlsx \(live.com\)](#). Electric mowers may last significantly longer. Manufacturers estimate 3,000-5,000 hours for electric mowers, according to [The Electric Advantage - MEAN GREEN MOWERS \(meangreenproducts.com\)](#), which equates to more than 10 years at 246 hours per year.

<sup>175</sup> Vermont Act 56 Tier III Technical Advisory Group 2021 ANNUAL REPORT

<sup>176</sup> Commercial cooling loadshape is used as an estimate of likely usage pattern for electric lawn equipment. This methodology is used in other jurisdictions offering electric lawn care equipment savings.

**COINCIDENCE FACTOR**

The summer Peak Coincidence Factor is assumed to be 91.3%.<sup>177</sup>

**Algorithm**

**CALCULATION OF ENERGY SAVINGS**

**ELECTRIC ENERGY AND FOSSIL FUEL SAVINGS**

Fuel switch measure (baseline is gas equipment):

Fuel switch / electrification measures must produce positive total energy savings (i.e., reduction in Btus at the premises) in order to qualify. This is determined as follows:

$$\begin{aligned} \Delta \text{SiteEnergySavings (MMBtu)} &= [\text{GasConsumptionReplaced}] - [\text{ElectricConsumptionAdded}] \\ &= [\text{Fuel}_{\text{baseline}} * 120,238/1,000,000] - [\text{Fuel}_{\text{baseline}} * \text{ED}_{\text{gasoline}} / (\text{ED}_{\text{electricity}} * \text{EER}_{\text{G} \rightarrow \text{E}}) * 3,412/1,000,000] \\ \text{Fuel}_{\text{baseline}} &= (\text{BSFC}_{\text{baseline}} * \text{hp}_{\text{baseline}} * \text{LF}_{\text{baseline}} * \text{Hours}) / (\text{Fuel Density}_{\text{gasoline}}) \end{aligned}$$

If SiteEnergySavings calculated above is positive, the measure is eligible.

The appropriate savings claim is dependent on which utilities are supporting the measure as provided in a table below:

Measure supported by:	Electric Utility claims (kWh):	Gas Utility claims (therms):
Electric utility only	SiteEnergySavings * 1,000,000/3,412	N/A
Electric and gas utility (Note utilities may make alternative agreements to how savings are allocated as long as total MMBtu savings remains the same).	%IncentiveElectric * SiteEnergySavings * 1,000,000/3,412	%IncentiveGas * SiteEnergySavings * 10
Gas utility only	N/A	SiteEnergySavings * 10

Where:

BSFC<sub>baseline</sub> = Brake Specific Fuel (Gasoline) Consumption Factor (lbs/hp-hr)  
= If unknown, use default values in the table below

hp<sub>baseline</sub> = Horsepower of the lawn mower  
= If unknown, use default values in the table below

LF<sub>baseline</sub> = The load factor is the average operational level of an engine as a fraction or percentage of the engine manufacturer’s maximum rated horsepower. Load factor is difficult to characterize since it is a strong function of the equipment use and operation. Load factors for various equipment types are presented in the table below.

<sup>177</sup> Based on analysis of Itron eShape data for Missouri, calibrated to Illinois loads, supplied by Ameren. The AC load during the utility’s peak hour is divided by the maximum AC load during the year.



- Hours = Annual operating hours of the lawn mower.  
= Values for various equipment types are presented in the table below.
- Fuel Density<sub>gasoline</sub> = Gasoline fuel density (assume 6.15 lbs/gal)<sup>178</sup>
- ED<sub>gasoline</sub> = Energy density of gasoline (assume 115.83 MJ/gal)<sup>178</sup>
- ED<sub>electricity</sub> = Energy density of electricity = 3.6 MJ/kWh
- EER<sub>G→E</sub> = Energy Economy Ratio = 3.4 (for switching from gasoline to electricity)<sup>179</sup>
- 120,238 = Btu content in one gallon of finished gasoline<sup>180</sup>
- 1,000,000 = Btu to MMBtu conversion

Equipment Type	BSFC <sub>baseline</sub> (lbs/hp-hr) <sup>186</sup>	hp <sub>baseline</sub> <sup>186</sup>	LF <sub>baseline</sub> <sup>181</sup>	Hours (hrs/year)	ΔkWh	ΔMMBtu	Site Energy Savings (MMBtu)
Riding Lawn Mower	0.775	21.4	38%	246	-2386	30.3	22.2
Push Lawn Mower	0.789	3.9	33%	161.6	-253	3.2	2.3

**SUMMER COINCIDENT PEAK DEMAND SAVINGS**

$$\Delta kW = -1 \times kW_{\text{battery draw}} \times CF$$

Where:

kW<sub>battery draw</sub> = The electric draw by the battery during charging. This varies based on the battery and charger specifications. If unknown use values in the table below.

Equipment Type	kW <sub>battery draw</sub>
Riding Lawn Mower	1.12 <sup>182</sup>
Push Lawn Mower	0.42 <sup>183</sup>

CF = Summer Peak Coincidence Factor = 91.3%<sup>184</sup>

<sup>178</sup> CARB (2022). CCI Emission Factor Database, “Fuel-Specific GHG” worksheet, available at [cci\\_emissionfactordatabase\\_2022-11-30.xlsx \(live.com\)](#).

<sup>179</sup> Energy Economy Ratio (EER) dimensionless value that represents the efficiency of a fuel as used in a powertrain as compared to a reference fuel used in the same powertrain. Source: CARB (2018), Low Carbon Fuel Standard Regulations: Table 5. EER Values for Fuels Used in Light- and Medium- Duty, and Heavy-Duty Applications. [RESO 18-34 LCFS Attachment A Final Reg Order \(ca.gov\)](#)

<sup>180</sup> [Energy conversion calculators - U.S. Energy Information Administration \(EIA\)](#)

<sup>181</sup> Conservative estimate given lack of definitive source. Useful life for commercial gasoline-powered mowers is 5 years, per CARB (2022). CCI Emission Factor Database, “Fuel-Specific GHG” worksheet, available at [cci\\_emissionfactordatabase\\_2022-11-30.xlsx \(live.com\)](#). Electric mowers may last significantly longer. Manufacturers estimate 3,000-5,000 hours for electric mowers, according to [The Electric Advantage - MEAN GREEN MOWERS \(meangreenproducts.com\)](#), which equates to more than 10 years at 246 hours per year.

<sup>182</sup> Vermont Act 56 Tier III Technical Advisory Group 2021 ANNUAL REPORT

<sup>183</sup> Massachusetts Residential Baseline Study, Guidehouse, 2020

<sup>184</sup> Based on analysis of Itron eShape data for Missouri, calibrated to Illinois loads, supplied by Ameren. The AC load during the utility’s peak hour is divided by the maximum AC load during the year.

**WATER AND OTHER NON-ENERGY IMPACT DESCRIPTIONS AND CALCULATION**

N/A

**DEEMED O&M COST ADJUSTMENT CALCULATION**

Replacement battery costs should be accounted for if likely to be required within the 10 year measure life.

**MEASURE CODE: CI-AGE-CELM-V01-240101**

**REVIEW DEADLINE: 1/1/2028**

## 4.2.Food Service Equipment End Use

### 4.2.1 Combination Oven

#### DESCRIPTION

This measure applies to both natural gas fired and electric high efficiency combination convection and steam ovens installed in a commercial kitchen.

This measure was developed to be applicable to the following program types: TOS, RF. If applied to other program types, the measure savings should be verified.

#### DEFINITION OF EFFICIENT EQUIPMENT

To qualify for this measure, the installed equipment must be a new natural gas or electric combination oven meeting the ENERGY STAR idle rate and cooking efficiency requirements as specified below.<sup>185</sup>

#### ENERGY STAR Requirements (Version 3.0, Effective January 12, 2023)

Fuel Type	Operation	Idle Rate (Btu/h for Gas, kW for Electric)	Cooking-Energy Efficiency, (%)
Natural Gas (5-40 Pan Capacity)	Steam Mode	$\leq 200P+6,511$	$\geq 41$
	Convection Mode	$\leq 140P+3,800$	$\geq 57$
Electric (5-40 Pan Capacity)	Steam Mode	$\leq 0.133P+0.6400$	$\geq 55$
	Convection Mode	$\leq 0.083P+0.35$	$\geq 78$
Electric (3-4 Pan Capacity)	Steam Mode	$\leq 0.60P$	$\geq 51$
	Convection Mode	$\leq 0.05P+0.55$	$\geq 70$

Note: P = Pan capacity as defined in Section 1.Y, of the Commercial Ovens Program Requirements Version 3.0<sup>186</sup>

#### DEFINITION OF BASELINE EQUIPMENT

The baseline equipment is a natural gas or electric combination oven that is not ENERGY STAR certified.

#### DEEMED LIFETIME OF EFFICIENT EQUIPMENT

The expected measure life is assumed to be 12 years.<sup>187</sup>

#### DEEMED MEASURE COST

The costs vary based on the efficiency and make of the equipment. Actual costs should be used. Otherwise<sup>188</sup>:

Oven Type & Capacity	Baseline Cost	Efficient Cost	Incremental Measure Cost
Electric < 15 Pan Capacity	\$13,919	\$16,189	\$2,269
Electric 15 – 30 Pan Capacity	\$18,966	\$21,247	\$2,281
Electric > 30 Pan Capacity	\$30,827	\$34,625	\$3,798
Gas < 15 Pan Capacity	\$15,406	\$19,338	\$3,932
Gas 15 – 30 Pan Capacity	\$20,292	\$24,509	\$4,217
Gas > 30 Pan Capacity	\$32,508	\$38,337	\$5,829

<sup>185</sup> ENERGY STAR Commercial Ovens Key Product Criteria, version 3.0, effective January 12, 2023

<sup>186</sup> Ibid. Pan capacity is defined as the number of steam table pans the combination oven is able to accommodate as per the ASTM F-1495-05 standard specification.

<sup>187</sup> The measure life is sourced from the Food Service Technology Center’s energy savings calculator for combination ovens.

<sup>188</sup> Costs are sourced from Food Service Technology Center 2016 ‘Combi\_2016\_Prices\_Updated’ which is also used in the ENERGY STAR Commercial Foodservice Savings Calculator, published March, 2021.

**LOADSHAPE**

Loadshape C01 - Commercial Electric Cooking

**COINCIDENCE FACTOR**

Summer Peak Coincidence Factor for measure is provided below for different building type:<sup>189</sup>

Location	CF
Fast Food Limited Menu	0.32
Fast Food Expanded Menu	0.41
Pizza	0.46
Full Service Limited Menu	0.51
Full Service Expanded Menu	0.36
Cafeteria	0.39

---



---

**Algorithm**

---



---

**CALCULATION OF SAVINGS**

**ELECTRIC ENERGY AND FOSSIL FUEL SAVINGS<sup>190</sup>**

Non Fuel Switch Measures

The algorithm below applies to electric combination ovens only.

$$\Delta kWh = (\Delta CookingEnergy_{ConvElec} + \Delta CookingEnergy_{SteamElec} + \Delta IdleEnergy_{ConvElec} + \Delta IdleEnergy_{SteamElec} + \Delta PreHeatEnergy_{Elec}) * Days / 1,000$$

The algorithm below applies to natural gas combination ovens only.

$$\Delta Therms = (\Delta CookingEnergy_{ConvGas} + \Delta CookingEnergy_{SteamGas} + \Delta IdleEnergy_{ConvGas} + \Delta IdleEnergy_{SteamGas} + \Delta PreHeatEnergy_{Gas}) * Days / 100,000$$

Fuel Switch/Electrification Measures

Fuel switch / electrification measures must produce positive total energy savings (i.e., reduction in Btus at the premises) in order to qualify. This is determined as follows:

$$\begin{aligned} \text{SiteEnergySavings (MMBTUs)} &= [\text{GasConsumptionReplaced}] - [\text{ElectricConsumptionAdded}] \\ &= [(\text{CookingEnergy}_{ConvGasBase} + \text{CookingEnergy}_{SteamGasBase} + \text{IdleEnergy}_{ConvGasBase} + \text{IdleEnergy}_{SteamGasBase} + \text{PreHeatEnergy}_{BaseGas}) * \text{Days} / 1,000,000] - \\ & \quad [(\text{CookingEnergy}_{ConvElecEE} + \text{CookingEnergy}_{SteamElecEE} + \text{IdleEnergy}_{ConvElecEE} + \text{IdleEnergy}_{SteamElecEE} + \text{PreHeatEnergy}_{EEElec}) * \text{Days} * 3.412 / 1,000,000] \end{aligned}$$

---

<sup>189</sup> Values taken from Minnesota Technical Reference Manual (Version 2.2, effective May 2, 2018), ‘Electric Oven and Range’ measure and are based upon “Project on Restaurant Energy Performance-End-Use Monitoring and Analysis”, Appendixes I and II, Claar, et. al., May 1985

<sup>190</sup> Algorithms and assumptions derived from ENERGY STAR Commercial Kitchen Equipment Savings Calculator, updated March 2021.

If SiteEnergySavings calculated above is positive, the measure is eligible.

The appropriate savings claim is dependent on which utilities are supporting the measure as provided in a table below:

Measure supported by:	Electric Utility claims (kWh):	Gas Utility claims (therms):
Electric utility only	SiteEnergySavings * 1,000,000/3,412	N/A
Electric and gas utility (Note utilities may make alternative agreements to how savings are allocated as long as total MMBtu savings remains the same).	%IncentiveElectric * SiteEnergySavings * 1,000,000/3,412	%IncentiveGas * SiteEnergySavings * 10
Gas utility only	N/A	SiteEnergySavings * 10

Where:

$\Delta\text{CookingEnergy}_{\text{ConvElec}}$  = Change in total daily cooking energy consumed by electric oven in convection mode

$$= \text{LB}_{\text{Elec}} * (\text{EFOOD}_{\text{ConvElec}} / \text{ElecEFF}_{\text{ConvBase}} - \text{EFOOD}_{\text{ConvElec}} / \text{ElecEFF}_{\text{ConvEE}}) * \%_{\text{Conv}}$$

$\Delta\text{CookingEnergy}_{\text{SteamElec}}$  = Change in total daily cooking energy consumed by electric oven in steam mode

$$= \text{LB}_{\text{Elec}} * (\text{EFOOD}_{\text{SteamElec}} / \text{ElecEFF}_{\text{SteamBase}} - \text{EFOOD}_{\text{SteamElec}} / \text{ElecEFF}_{\text{SteamEE}}) * \%_{\text{Steam}}$$

$\Delta\text{IdleEnergy}_{\text{ConvElec}}$  = Change in total daily idle energy consumed by electric oven in convection mode

$$= [(\text{ElecIDLE}_{\text{ConvBase}} * ((\text{HOURS} - \text{LB}_{\text{Elec}} / \text{ElecPC}_{\text{ConvBase}}) * \%_{\text{Conv}})) - (\text{ElecIDLE}_{\text{ConvEE}} * ((\text{HOURS} - \text{LB}_{\text{Elec}} / \text{ElecPC}_{\text{ConvEE}}) * \%_{\text{Conv}}))]$$

$\Delta\text{IdleEnergy}_{\text{SteamElec}}$  = Change in total daily idle energy consumed by electric oven in convection mode

$$= [(\text{ElecIDLE}_{\text{SteamBase}} * ((\text{HOURS} - \text{LB}_{\text{Elec}} / \text{ElecPC}_{\text{SteamBase}}) * \%_{\text{Steam}})) - (\text{ElecIDLE}_{\text{SteamEE}} * ((\text{HOURS} - \text{LB}_{\text{Elec}} / \text{ElecPC}_{\text{SteamEE}}) * \%_{\text{Steam}}))]$$

$\Delta\text{PreHeatEnergy}_{\text{Elec}}$  = Change in total daily energy consumed by electric oven to preheat

$$= \text{Preheat}_{\text{BaseElec}} - \text{Preheat}_{\text{EEElec}}$$

$\Delta\text{CookingEnergy}_{\text{ConvGas}}$  = Change in total daily cooking energy consumed by gas oven in convection mode

$$= \text{LB}_{\text{Gas}} * (\text{EFOOD}_{\text{ConvGas}} / \text{GasEFF}_{\text{ConvBase}} - \text{EFOOD}_{\text{ConvGas}} / \text{GasEFF}_{\text{ConvEE}}) * \%_{\text{Conv}}$$

$\Delta\text{CookingEnergy}_{\text{SteamGas}}$  = Change in total daily cooking energy consumed by gas oven in steam mode

$$= \text{LB}_{\text{Gas}} * (\text{EFOOD}_{\text{SteamGas}} / \text{GasEFF}_{\text{SteamBase}} - \text{EFOOD}_{\text{SteamGas}} / \text{GasEFF}_{\text{SteamEE}}) * \%_{\text{Steam}}$$

$\Delta\text{IdleEnergy}_{\text{ConvGas}}$  = Change in total daily idle energy consumed by gas oven in convection mode

$$= [(\text{GasIDLE}_{\text{ConvBase}} * ((\text{HOURS} - \text{LB}_{\text{Gas}} / \text{GasPC}_{\text{ConvBase}}) * \%_{\text{Conv}})) - (\text{GasIDLE}_{\text{ConvEE}} * ((\text{HOURS} - \text{LB}_{\text{Gas}} / \text{GasPC}_{\text{ConvEE}}) * \%_{\text{Conv}}))]$$

$\Delta IdleEnergy_{SteamGas}$	<p>= Change in total daily idle energy consumed by gas oven in convection mode</p> <p>= <math>[(GasIDLE_{SteamBase} * ((HOURS - LB_{Gas}/GasPC_{SteamBase}) * \%_{Steam})) - (GasIDLE_{SteamEE} * ((HOURS - LB_{Gas}/GasPC_{SteamEE}) * \%_{Steam}))]</math></p>
$\Delta PreHeatEnergy_{Gas}$	<p>= Change in total daily energy consumed by gas oven to preheat</p> <p>= <math>Preheat_{BaseGas} - Preheat_{EEGas}</math></p>
$CookingEnergy_{ConvElecEE}$	<p>= Total daily cooking energy consumed by new ENERGY STAR electric oven in convection mode (for fuel switch measure)</p> <p>= <math>LB_{Elec} * (EFOOD_{ConvElec} / ElecEFF_{ConvEE}) * \%_{Conv}</math></p>
$CookingEnergy_{SteamElecEE}$	<p>= Total daily cooking energy consumed by new ENERGY STAR electric oven in steam mode (for fuel switch measure)</p> <p>= <math>LB_{Elec} * (EFOOD_{SteamElec} / ElecEFF_{SteamEE}) * \%_{Steam}</math></p>
$IdleEnergy_{ConvElecEE}$	<p>= Total daily idle energy consumed by new ENERGY STAR electric oven in convection mode (for fuel switch measure)</p> <p>= <math>(ElecIDLE_{ConvEE} * ((HOURS - LB_{Elec}/ElecPC_{ConvEE}) * \%_{Conv}))</math></p>
$IdleEnergy_{SteamElecEE}$	<p>= Total daily idle energy consumed by new ENERGY STAR electric oven in convection mode (for fuel switch measure)</p> <p>= <math>(ElecIDLE_{SteamEE} * ((HOURS - LB_{Elec}/ElecPC_{SteamEE}) * \%_{Steam}))</math></p>
$CookingEnergy_{ConvGasBase}$	<p>= Total daily cooking energy consumed by baseline gas oven in convection mode (for fuel switch measure)</p> <p>= <math>LB_{Gas} * (EFOOD_{ConvGas} / GasEFF_{ConvBase}) * \%_{Conv}</math></p>
$CookingEnergy_{SteamGasBase}$	<p>= Total daily cooking energy consumed by baseline gas oven in steam mode (for fuel switch measure)</p> <p>= <math>LB_{Gas} * (EFOOD_{SteamGas} / GasEFF_{SteamBase}) * \%_{Steam}</math></p>
$IdleEnergy_{ConvGasBase}$	<p>= Total daily idle energy consumed by baseline gas oven in convection mode (for fuel switch measure)</p> <p>= <math>(GasIDLE_{ConvBase} * ((HOURS - LB_{Gas}/GasPC_{ConvBase}) * \%_{Conv}))</math></p>
$IdleEnergy_{SteamGasBase}$	<p>= Total daily idle energy consumed by baseline gas oven in convection mode (for fuel switch measure)</p> <p>= <math>[(GasIDLE_{SteamBase} * ((HOURS - LB_{Gas}/GasPC_{SteamBase}) * \%_{Steam}))]</math></p>

Where:

$LB_{Elec}$	<p>= Estimated mass of food cooked per day for electric oven (lbs/day)</p> <p>= Custom, or if unknown, use 200 lbs (If P &lt;15) or 250 lbs (If P &gt;= 15)</p>
$EFOOD_{ConvElec}$	<p>= Energy absorbed by food product for electric oven in convection mode</p> <p>= Custom or if unknown, use 73.2 Wh/lb</p>
$ElecEFF$	<p>= Cooking energy efficiency of electric oven</p> <p>= Custom or if unknown, use values from table below</p>

	Base	EE
ElecEFF <sub>Conv</sub>	72%	78%
ElecEFF <sub>Steam</sub>	52%	55%

%<sub>Conv</sub> = Percentage of time in convection mode

= Custom or if unknown, use 50%

EFOOD<sub>SteamElec</sub> = Energy absorbed by food product for electric oven in steam mode

= Custom or if unknown, use 30.8 Wh/lb

%<sub>steam</sub> = Percentage of time in steam mode

= 1 - %<sub>conv</sub>

ElecIDLE<sub>Base</sub> = Idle energy rate (W) of baseline electric oven

= Custom or if unknown, use values from table below

Pan Capacity	Convection Mode (ElecIDLE <sub>ConvBase</sub> )	Steam Mode (ElecIDLE <sub>SteamBase</sub> )
< 15	1,754	5,260
> = 15 to <30	2,966	8,866
>= 30	4,418	11,875

HOURS = Average daily hours of operation

= Custom or if unknown, use 12 hours

ElecPC<sub>Base</sub> = Production capacity (lbs/hr) of baseline electric oven

= Custom of if unknown, use values from table below

Pan Capacity	Convection Mode (ElecPC <sub>ConvBase</sub> )	Steam Mode (ElecPC <sub>SteamBase</sub> )
< 15	79	126
> = 15	166	295

ElecIDLE<sub>ConvEE</sub> = Idle energy rate of ENERGY STAR electric oven in convection mode

= Custom or if unknown, use default below:

= (0.083\*P +0.350) \* 1000 for 5-40 Pan Capacity

= (0.05\*P +0.55) \* 1000 for 3-4 Pan Capacity

ElecPC<sub>EE</sub> = Production capacity (lbs/hr) of ENERGY STAR electric oven

= Custom of if unknown, use values from table below

Pan Capacity	Convection Mode (ElecPC <sub>ConvEE</sub> )	Steam Mode (ElecPC <sub>SteamEE</sub> )
< 15	119	177
> = 15	201	349

ElecIDLE<sub>SteamEE</sub> = Idle energy rate of ENERGY STAR electric oven in steam mode

= Custom or if unknown, use default below:

=  $(0.133 * P + 0.64) * 1000$  for 5-40 Pan Capacity

=  $(0.60 * P) * 1000$  for 3-4 Pan Capacity

**Preheat<sub>BaseElec</sub>** = Total preheat energy consumption per day of baseline electric unit (Wh)  
 = Custom or if unknown, use default below:

Pan Capacity	Preheat <sub>BaseElec</sub>
< 15	1,635
> = 15	3,146

**Preheat<sub>EEElec</sub>** = Total preheat energy consumption per day of ENERGY STAR electric unit (Wh)

Pan Capacity	Preheat <sub>EEElec</sub>
< 15	997
> = 15	1,633

**Days** = Days of operation per year  
 = Custom or if unknown, use 365 days per year

**1,000** = Wh to kWh conversion factor

**LB<sub>Gas</sub>** = Estimated mass of food cooked per day for gas oven (lbs/day)  
 = Custom, or if unknown, use 200 lbs (If P <15), 250 lbs (If 15 <= P <= 30), or 400 lbs (If P = >30)

**E<sub>FOODConvGas</sub>** = Energy absorbed by food product for gas oven in convection mode  
 = Custom or if unknown, use 250 Btu/lb

**GasEFF** = Cooking energy efficiency of gas oven  
 = Custom or if unknown, use values from table below

	Base	EE
GasEFF <sub>Conv</sub>	49%	57%
GasEFF <sub>Steam</sub>	37%	41%

**E<sub>FOODSteamGas</sub>** = Energy absorbed by food product for gas oven in steam mode  
 = Custom or if unknown, use 105 Btu/lb

**GasIDLE<sub>Base</sub>** = Idle energy rate (Btu/hr) of baseline gas oven  
 = Custom or if unknown, use values from table below

Pan Capacity	Convection Mode (GasIDLE <sub>ConvBase</sub> )	Steam Mode (GasIDLE <sub>SteamBase</sub> )
< 15	9,840	24,003
15-30	11,734	27,795
>30	15,376	27,957

**GasPC<sub>Base</sub>** = Production capacity (lbs/hr) of baseline gas oven  
 = Custom of if unknown, use values from table below



Pan Capacity	Convection Mode (GasPC <sub>ConvBase</sub> )	Steam Mode (GasPC <sub>SteamBase</sub> )
< 15	125	195
15-30	176	211
>30	392	579

GasIDLE<sub>ConvEE</sub> = Idle energy rate of ENERGY STAR gas oven in convection mode  
 = Custom or if unknown, use default below:  
 = 140\*P + 3,800

GasPC<sub>EE</sub> = Production capacity (lbs/hr) of ENERGY STAR gas oven  
 = Custom of if unknown, use values from table below

Pan Capacity	Convection Mode (GasPC <sub>ConvEE</sub> )	Steam Mode (GasPC <sub>SteamEE</sub> )
< 15	124	172
15-30	210	277
>30	394	640

GasIDLE<sub>SteamEE</sub> = Idle energy rate of ENERGY STAR gas oven in steam mode  
 = Custom or if unknown, use default below:  
 = 200 \* P +6511

Preheat<sub>BaseGas</sub> = Total preheat energy consumption per day of baseline gas unit (BTU)  
 = Custom or if unknown, use default below:

Pan Capacity	Preheat <sub>BaseGas</sub>
< 15	10,964
> = 15	15,844

Preheat<sub>EEGas</sub> = Total preheat energy consumption per day of ENERGY STAR gas unit (BTU)  
 = Custom or if unknown, use default below:

Pan Capacity	Preheat <sub>EEGas</sub>
< 15	4,467
> = 15	10,638

100,000 = Conversion factor from Btu to therms

3.412 = Conversion factor from Wh to Btu

1,000,000 = Conversion factor from Btu to MMBtu

**For example**, a 10-pan capacity ENERGY STAR electric combination oven in place of a baseline electric oven would save:

$$\begin{aligned} \Delta kWh &= (\Delta CookingEnergy_{ConvElec} + \Delta CookingEnergy_{SteamElec} + \Delta IdleEnergy_{ConvElec} + \Delta IdleEnergy_{SteamElec} + \\ &\quad \Delta PreHeatEnergy_{Elec}) * Days / 1,000 \\ \Delta CookingEnergy_{ConvElec} &= 200 * (73.2 / 0.72 - 73.2 / 0.78) * 0.50 \\ &= 782 \text{ Wh} \\ \Delta CookingEnergy_{SteamElec} &= 200 * (30.8 / 0.52 - 30.8 / 0.55) * (1 - 0.50) \\ &= 323 \text{ Wh} \\ \Delta IdleEnergy_{ConvElec} &= [(1,754 * ((12 - 200/79) * 0.50)) - (1,180 * ((12 - 200/119) * 0.50))] \\ &= 2215 \text{ Wh} \\ \Delta IdleEnergy_{SteamElec} &= [(5,260 * ((12 - 200/126) * (1 - 0.50))) - (1,970 * ((12 - 200/177) * (1 - \\ &\quad 0.50)))] \\ &= 16,678 \text{ Wh} \\ \Delta PreHeatEnergy_{Elec} &= 1,635 - 997 \\ &= 638 \text{ Wh} \\ \Delta kWh &= (782 + 323 + 2215 + 16,678 + 638) * 365 / 1,000 \\ &= 7,532 \text{ kWh} \end{aligned}$$

**For example**, an ENERGY STAR 10-pan capacity electric combination oven in place of a baseline gas combination oven would save:

$$\begin{aligned} \text{SiteEnergySavings (MMBTUs)} &= [\text{GasConsumptionReplaced}] - [\text{ElectricConsumptionAdded}] \\ &= [(\text{CookingEnergy}_{\text{ConvGasBase}} + \text{CookingEnergy}_{\text{SteamGasBase}} + \text{IdleEnergy}_{\text{ConvGasBase}} + \text{IdleEnergy}_{\text{SteamGasBase}} + \text{PreHeatEnergy}_{\text{BaseGas}}) \\ &\quad * \text{Days} / 1,000,000] - \\ &\quad [(\text{CookingEnergy}_{\text{ConvElecEE}} + \text{CookingEnergy}_{\text{SteamElecEE}} + \text{IdleEnergy}_{\text{ConvElecEE}} + \text{IdleEnergy}_{\text{SteamElecEE}} + \text{PreHeatEnergy}_{\text{EEElec}}) * \\ &\quad \text{Days} * 3.412 / 1,000,000] \end{aligned}$$

$$\begin{aligned} \text{CookingEnergy}_{\text{ConvGasBase}} &= 200 * (250 / 0.49) * 0.50 \\ &= 51,020 \text{ Btu} \end{aligned}$$

$$\begin{aligned} \text{CookingEnergy}_{\text{SteamGasBase}} &= 200 * (105 / 0.37) * (1 - 0.50) \\ &= 28,378 \text{ Btu} \end{aligned}$$

$$\begin{aligned} \text{IdleEnergy}_{\text{ConvGasBase}} &= 9,840 * ((12 - 200/125) * 0.50)) \\ &= 51,168 \text{ Btu} \end{aligned}$$

$$\begin{aligned} \text{IdleEnergy}_{\text{SteamGasBase}} &= 24,003 * ((12 - 200/195) * (1 - 0.50)) \\ &= 131,709 \text{ Btu} \end{aligned}$$

$$\text{PreHeatEnergy}_{\text{BaseGas}} = 10,964 \text{ Btu}$$

$$\begin{aligned} \text{CookingEnergy}_{\text{ConvElecEE}} &= 200 * (73.2 / 0.78) * 0.50 \\ &= 9,385 \text{ Wh} \end{aligned}$$

$$\begin{aligned} \text{CookingEnergy}_{\text{SteamElecEE}} &= 200 * (30.8 / 0.55) * (1 - 0.50) \\ &= 5,600 \text{ Wh} \end{aligned}$$

$$\begin{aligned} \text{IdleEnergy}_{\text{ConvElecEE}} &= 1,180 * ((12 - 200/119) * 0.50) \\ &= 6,088 \text{ Wh} \end{aligned}$$

$$\begin{aligned} \text{IdleEnergy}_{\text{SteamElecEE}} &= 1,970 * ((12 - 200/177) * (1 - 0.50))) \\ &= 10,707 \text{ Wh} \end{aligned}$$

$$\text{PreHeatEnergy}_{\text{EEElec}} = 997 \text{ Wh}$$

$$\begin{aligned} \text{SiteEnergySavings (MMBTUs)} &= [(51,020 + 28,378 + 51,168 + 131,709 + 10,964) * 365 / 1,000,000] \\ &\quad - [(9,385 + 5,600 + 6,088 + 10,707 + 997) * 365 * 3.412 / 1,000,000] \\ &= 58.9 \text{ MMBtu} \end{aligned}$$

$$\begin{aligned} \text{If supported by an electric utility;} \quad \Delta \text{kWh} &= \Delta \text{SiteEnergySavings} * 1,000,000 / 3,412 \\ &= 58.9 * 1,000,000 / 3,412 \\ &= 17,263 \text{ kWh} \end{aligned}$$

### SUMMER COINCIDENT PEAK DEMAND SAVINGS

For non-fuel switch measures:

$$\begin{aligned} \Delta \text{kW} &= ((\Delta \text{CookingEnergy}_{\text{ConvElec}} + \Delta \text{CookingEnergy}_{\text{SteamElec}} + \Delta \text{IdleEnergy}_{\text{ConvElec}} + \\ &\quad \Delta \text{IdleEnergy}_{\text{SteamElec}} + \Delta \text{PreHeatEnergy}_{\text{Elec}}) / (1,000 * \text{HOURS}) * \text{CF} \end{aligned}$$

For fuel switch measures:

$$\Delta kW = - ((CookingEnergy_{ConvElecEE} + CookingEnergy_{SteamElecEE} + IdleEnergy_{ConvElecEE} + IdleEnergy_{SteamElecEE} + PreHeatEnergy_{EEElec}) / (1,000 * HOURS) * CF$$

Where:

CF = Summer peak coincidence factor is dependent on building type:<sup>191</sup>

Location	CF
Fast Food Limited Menu	0.32
Fast Food Expanded Menu	0.41
Pizza	0.46
Full Service Limited Menu	0.51
Full Service Expanded Menu	0.36
Cafeteria	0.39

All other variables as defined above.

**For example**, a 10-pan capacity electric combination oven in a Full Service Limited Menu restaurant would save:

$$\begin{aligned} \Delta kW &= \Delta kWh / (HOURS * DAYS) * CF \\ &= (782 + 323 + 2215 + 16,678 + 638) / (1000 * 12) * 0.51 \\ &= 0.88 kW \end{aligned}$$

**FOSSIL FUEL SAVINGS**

Calculation provided together with Electric Energy Savings above.

**WATER IMPACT DESCRIPTIONS AND CALCULATION**

N/A

**DEEMED O&M COST ADJUSTMENT CALCULATION**

N/A

**COST EFFECTIVENESS SCREENING AND LOAD REDUCTION FORECASTING WHEN FUEL SWITCHING**

This measure can involve fuel switching from fossil fuel to electric.

For the purposes of forecasting load reductions due to fuel switch projects per Section 16-111.5B, changes in site energy use at the customer’s meter (using ΔkWh algorithm below), customer switching estimates, NTG, and any other adjustment factors deemed appropriate, should be used.

The inputs to cost effectiveness screening should reflect the actual impacts on the electric and fuel consumption at the customer meter and, for fuel switching measures, should therefore reflect the decrease in one fuel and increase in another, as opposed to the single savings value calculated in the “Electric and Fossil Fuel Energy Savings” section

<sup>191</sup>Values taken from Minnesota Technical Reference Manual (Version 2.2, effective May 2, 2018), ‘Electric Oven and Range’ measure and are based upon “Project on Restaurant Energy Performance-End-Use Monitoring and Analysis”, Appendixes I and II, Claar, et. al., May 1985

above. Therefore in addition to the calculation of savings claimed, the following values should be used to assess the cost effectiveness of the measure.

$$\begin{aligned} \Delta\text{Therms} &= [\text{Gas Cooking Consumption Replaced}] \\ &= [(\text{CookingEnergy}_{\text{ConvGasBase}} + \text{CookingEnergy}_{\text{SteamGasBase}} + \text{IdleEnergy}_{\text{ConvGasBase}} + \\ &\quad \text{IdleEnergy}_{\text{SteamGasBase}} + \text{PreHeatEnergy}_{\text{BaseGas}}) * \text{Days} / 100,000] \\ \Delta\text{kWh} &= [\text{Electric Cooking Consumption Added}] \\ &= - [(\text{CookingEnergy}_{\text{ConvElecEE}} + \text{CookingEnergy}_{\text{SteamElecEE}} + \text{IdleEnergy}_{\text{ConvElecEE}} + \\ &\quad \text{IdleEnergy}_{\text{SteamElecEE}} + \text{PreHeatEnergy}_{\text{EEElec}}) * \text{Days}/1,000] \end{aligned}$$

**MEASURE CODE: CI-FSE-CBOV-V05-240101**

**REVIEW DEADLINE: 1/1/2028**

## 4.2.2 Commercial Solid and Glass Door Refrigerators & Freezers

### DESCRIPTION

This measure relates to the installation of a new reach-in commercial refrigerator or freezer meeting ENERGY STAR efficiency standards. ENERGY STAR labeled commercial refrigerators and freezers are more energy efficient because they are designed with components such as ECM evaporator and condenser fan motors, hot gas anti-sweat heaters, or high-efficiency compressors, which will significantly reduce energy consumption.

This measure was developed to be applicable to the following program types: TOS and NC. If applied to other program types, the measure savings should be verified.

### DEFINITION OF EFFICIENT EQUIPMENT

In order for this characterization to apply, the efficient equipment is assumed to be a new ENERGY STAR certified vertical closed solid or glass door refrigerator or freezer meeting energy consumptions requirements as determined by door type (solid or glass) and refrigerated volume (V).

#### ENERGY STAR Requirements (Version 5.0, Effective December 22, 2022)

Volume (ft <sup>3</sup> )	Maximum Daily Energy Consumption (kWh/day)	
	Refrigerator	Freezer
<b>Vertical Closed</b>		
<b>Solid Door</b>		
0 < V < 15	≤ 0.0267V + 0.8	≤ 0.21V + 0.9
15 ≤ V < 30	≤ 0.05V + 0.45	≤ 0.12V + 2.248
30 ≤ V < 50	≤ 0.05V + 0.45	≤ 0.2578V - 1.8864
V ≥ 50	≤ 0.025V + 1.6991	≤ 0.14V + 4.0
<b>Glass Door</b>		
0 < V < 15	≤ 0.095V + 0.445	≤ 0.232V + 2.36
15 ≤ V < 30	≤ 0.05V + 1.12	
30 ≤ V < 50	≤ 0.076V + 0.34	
V ≥ 50	≤ 0.105V - 1.111	

### DEFINITION OF BASELINE EQUIPMENT

In order for this characterization to apply, the baseline equipment is assumed to be a new vertical closed solid or glass door refrigerator or freezer that is not ENERGY STAR certified.

### DEEMED LIFETIME OF EFFICIENT EQUIPMENT

The expected measure life is assumed to be 12 years.<sup>192</sup>

### DEEMED MEASURE COST

The incremental capital cost for this measure is provided in the table below.<sup>193</sup>

<sup>192</sup>2008 Database for Energy-Efficiency Resources (DEER), Version 2008.2.05, "Effective/Remaining Useful Life Values", California Public Utilities Commission, December 16, 2008.

<sup>193</sup>Energy Star, 2021. ENERGY STAR Version 5.0 Commercial Refrigerators and Freezers Data Pack.xlsx. From Incremental Cost and Payback tab, an average \$/sq ft value was calculated and applied to the average volumes for each refrigerator and freezer category – rounded to the nearest dollar (from product data tabs, and 2023 Energy Star QPL)

Door Type	Volume	Refrigerator	Freezer
Solid Door	$0 < V < 15$	\$53	\$27
	$15 \leq V < 30$	\$121	\$57
	$30 \leq V < 50$	\$247	\$119
	$50 \leq V$	\$401	\$196
Glass Door	$0 < V < 15$	\$51	\$19
	$15 \leq V < 30$	\$125	\$56
	$30 \leq V < 50$	\$252	\$114
	$50 \leq V$	\$420	\$201

**LOADSHAPE**

Loadshape C23 - Commercial Refrigeration

**COINCIDENCE FACTOR**

The summer peak coincidence factor for this measure is assumed to be 0.937.<sup>194</sup>

---

**Algorithm**

---

**CALCULATION OF SAVINGS**

**ELECTRIC ENERGY SAVINGS**

$$\Delta kWh = (kWh_{base} - kWh_{ee}) * 365.25$$

Where:

$kWh_{base}$  = baseline maximum daily energy consumption in kWh

= calculated using actual chilled or frozen compartment volume (V) of the efficient unit as shown in the table below.

Type	$kWh_{base}^{195}$
Solid Door Refrigerator	$0.05 * V + 1.36$
Glass Door Refrigerator	$0.1 * V + 0.86$
Solid Door Freezer	$0.22 * V + 1.38$
Glass Door Freezer	$0.29 * V + 2.95$

$kWh_{ee}^{196}$  = efficient maximum daily energy consumption in kWh

= actual if known. If unknown can be calculated using actual chilled or frozen compartment volume (V) of the efficient unit as shown in the table below.

Volume (ft <sup>3</sup> )	kWh <sub>ee</sub>	
	Refrigerator	Freezer
<b>Vertical Closed</b>		
<b>Solid Door</b>		

<sup>194</sup> The CF for Commercial Refrigeration was calculated based upon the Ameren provided eShapes

<sup>195</sup> Federal standards for equipment manufactured on or after March 27, 2017: 10 CFR §431.66 - Energy Conservation Standards for Commercial Refrigerators, Freezers and Refrigerator-Freezers.

<sup>196</sup> ENERGY STAR Program Requirements for Commercial Refrigerators and Freezers Partner Commitments Version 5.0, effective December 22, 2022

Volume (ft <sup>3</sup> )	kW <sub>h</sub>	
	Refrigerator	Freezer
0 < V < 15	≤ 0.0267V + 0.8	≤ 0.21V + 0.9
15 ≤ V < 30	≤ 0.05V + 0.45	≤ 0.12V + 2.248
30 ≤ V < 50	≤ 0.05V + 0.45	≤ 0.2578V -1.8864
V ≥ 50	≤ 0.025V + 1.6991	≤ 0.14V + 4.0
<b>Glass Door</b>		
0 < V < 15	≤ 0.095V + 0.445	≤ 0.232V + 2.36
15 ≤ V < 30	≤ 0.05V + 1.12	
30 ≤ V < 50	≤ 0.076V + 0.34	
V ≥ 50	≤ 0.105V - 1.111	

V = the chilled or frozen compartment volume (ft<sup>3</sup>) (as defined in the Association of Home Appliance Manufacturers Standard HRF1–1979)

= Actual installed

365.25 = days per year

For example, a solid door refrigerator with a volume of 15 would save

$$\Delta \text{kWh} = (2.11 - 1.20) * 365.25$$

$$= 332 \text{ kWh}$$

**SUMMER COINCIDENT PEAK DEMAND SAVINGS**

$$\Delta \text{kW} = \Delta \text{kWh} / \text{HOURS} * \text{CF}$$

Where:

HOURS = equipment is assumed to operate continuously, 24 hours per day, 365.25 days per year.  
= 8766

CF = Summer Peak Coincidence Factor for measure  
= 0.937

**For example**, a solid door refrigerator with a volume of 15 would save

$$\Delta \text{kW} = 332 / 8766 * .937$$

$$= 0.0355 \text{ kW}$$

**FOSSIL FUEL SAVINGS**

N/A

**WATER IMPACT DESCRIPTIONS AND CALCULATION**

N/A

**DEEMED O&M COST ADJUSTMENT CALCULATION**

N/A



**MEASURE CODE: CI-FSE-CSDO-V03-240101**

**REVIEW DEADLINE: 1/1/2028**

### 4.2.3 Commercial Steam Cooker

#### DESCRIPTION

To qualify for this measure the installed equipment must be an ENERGY STAR® steamer in place of a standard steamer in a commercial kitchen. Savings are presented dependent on the pan capacity and corresponding idle rate at heavy load cooking capacity and if the steamer is gas or electric.

This measure was developed to be applicable to the following program types: TOS. If applied to other program types, the measure savings should be verified.

#### DEFINITION OF EFFICIENT EQUIPMENT

To qualify for this measure the installed equipment must be as follows:

Gas	Electric
ENERGY STAR® qualified with 38% minimum cooking energy efficiency at heavy load (potato) cooking capacity for gas steam cookers.	ENERGY STAR® qualified with 50% minimum cooking energy efficiency at heavy load (potato) cooking capacity for electric steam cookers.

#### DEFINITION OF BASELINE EQUIPMENT

The baseline condition is assumed to be a non-ENERGY STAR® commercial steamer at end of life. It is assumed that the efficient equipment and baseline equipment have the same number of pans.

#### DEEMED LIFETIME OF EFFICIENT EQUIPMENT

The expected measure life is assumed to be 12 years.<sup>197</sup>

#### DEEMED MEASURE COST

The incremental capital cost for this measure uses actual costs, otherwise use costs outlined below.<sup>198</sup>

Equipment Type	Baseline Equipment Cost	Efficient Equipment Cost	Incremental Cost
Electric	\$5,444	\$8,201	\$2,758
Gas	\$10,265	\$12,324	\$2,059

#### LOADSHAPE

Loadshape C01 - Commercial Electric Cooking

#### COINCIDENCE FACTOR

Summer Peak Coincidence Factor for measure is provided below for different building type:<sup>199</sup>

Location	CF
Fast Food Limited Menu	0.32
Fast Food Expanded Menu	0.41
Pizza	0.46
Full Service Limited Menu	0.51

<sup>197</sup>California DEER 2008 which is also used by both the Food Service Technology Center and ENERGY STAR®.

<sup>198</sup> Costs taken from California "SWFS005-03\_Steamers\_2022\_Price\_Updated"

<sup>199</sup> Values taken from Minnesota Technical Reference Manual (Version 2.2, effective May 2, 2018), 'Electric Oven and Range' measure and are based upon "Project on Restaurant Energy Performance-End-Use Monitoring and Analysis", Appendixes I and II, Claar, et. al., May 1985. Unknown is an average of other location types

Location	CF
Full Service Expanded Menu	0.36
Cafeteria	0.39
Unknown	0.408

**Algorithm**

**CALCULATION OF SAVINGS**

Formulas below are applicable to both gas and electric steam cookers. Please use appropriate lookup values and identified flags.

**ENERGY SAVINGS AND FOSSIL FUEL SAVINGS**

Non Fuel Switch Measures

The algorithm below applies to ENERGY STAR electric steam cooker compared to baseline electric steam cooker:

$$\Delta kWh = (\Delta \text{Idle Energy} + \Delta \text{Preheat Energy} + \Delta \text{Cooking Energy}) * \text{Days}$$

The algorithm below applies to ENERGY STAR gas steam cooker compared to baseline gas steam cooker:

$$\Delta \text{Therms} = (\Delta \text{Idle Energy} + \Delta \text{Preheat Energy} + \Delta \text{Cooking Energy}) * 1/100,000 * \text{Days}$$

Fuel Switch/Electrification Measures

Fuel switch / electrification measures must produce positive total energy savings (i.e., reduction in Btus at the premises) in order to qualify. This is determined as follows:

$$\begin{aligned} \text{SiteEnergySavings (MMBTUs)} &= [\text{GasConsumptionReplaced}] - [\text{ElectricConsumptionAdded}] \\ &= [(\text{Idle Energy}_{\text{GasBase}} + \text{Preheat Energy}_{\text{GasBase}} + \text{Cooking Energy}_{\text{GasBase}}) * \\ &\quad 1/1,000,000 * \text{Days}] - \\ &\quad [(\text{Idle Energy}_{\text{ElecEE}} + \text{Preheat Energy}_{\text{ElecEE}} + \text{Cooking Energy}_{\text{ElecEE}}) * \\ &\quad 3412/1,000,000 * \text{Days}] \end{aligned}$$

If SiteEnergySavings calculated above is positive, the measure is eligible.

The appropriate savings claim is dependent on which utilities are supporting the measure as provided in a table below:

Measure supported by:	Electric Utility claims (kWh):	Gas Utility claims (therms):
Electric utility only	SiteEnergySavings * 1,000,000/3,412	N/A
Electric and gas utility (Note utilities may make alternative agreements to how savings are allocated as long as total MMBtu savings remains the same).	%IncentiveElectric * SiteEnergySavings * 1,000,000/3,412	%IncentiveGas * SiteEnergySavings * 10
Gas utility only	N/A	SiteEnergySavings * 10

Where:

$$\Delta \text{Idle Energy} = (((1 - \text{CSM}_{\% \text{Baseline}}) * \text{IDLE}_{\text{BASE}} + \text{CSM}_{\% \text{Baseline}} * \text{PC}_{\text{BASE}} * E_{\text{FOOD}} / \text{EFF}_{\text{BASE}}) * (\text{HOURS}_{\text{day}} - (F / \text{PC}_{\text{BASE}}) - (\text{PRE}_{\text{number}} * \text{PRE}_{\text{TimeBase}}))) - (((1 - \text{CSM}_{\% \text{ENERGYSTAR}}) * \text{IDLE}_{\text{ENERGYSTAR}} + \text{CSM}_{\% \text{ENERGYSTAR}} * \text{PC}_{\text{ENERGYSTAR}} * E_{\text{FOOD}} / \text{EFF}_{\text{ENERGYSTAR}}) * (\text{HOURS}_{\text{Day}} - (F / \text{PC}_{\text{ENERGYSTAR}}) - (\text{PRE}_{\text{number}} * \text{PRE}_{\text{TimeEE}}))))$$

$$\Delta \text{Preheat Energy} = (\text{PRE}_{\text{number}} * (\text{PRE}_{\text{heatEnergyBase}} - \text{PRE}_{\text{heatEnergyEE}}))$$

$$\Delta \text{Cooking Energy} = ((1 / \text{EFF}_{\text{BASE}}) - (1 / \text{EFF}_{\text{ENERGYSTAR}})) * F * E_{\text{FOOD}}$$

$$\text{Idle Energy}_{\text{GasBase}} = (((1 - \text{CSM}_{\% \text{Baseline}}) * \text{IDLE}_{\text{BASE}} + \text{CSM}_{\% \text{Baseline}} * \text{PC}_{\text{BASE}} * E_{\text{FOOD}} / \text{EFF}_{\text{BASE}}) * (\text{HOURS}_{\text{day}} - (F / \text{PC}_{\text{BASE}}) - (\text{PRE}_{\text{number}} * \text{PRE}_{\text{TimeGasBase}})))$$

$$\text{Preheat Energy}_{\text{GasBase}} = (\text{PRE}_{\text{number}} * \text{Pre}_{\text{heatEnergyGasBase}})$$

$$\text{Cooking Energy}_{\text{GasBase}} = (1 / \text{EFF}_{\text{BASE}}) * F * E_{\text{FOOD}}$$

$$\text{Idle Energy}_{\text{ElecEE}} = (((1 - \text{CSM}_{\% \text{ENERGYSTAR}}) * \text{IDLE}_{\text{ENERGYSTAR}} + \text{CSM}_{\% \text{ENERGYSTAR}} * \text{PC}_{\text{ENERGY}} * E_{\text{FOOD}} / \text{EFF}_{\text{ENERGYSTAR}}) * (\text{HOURS}_{\text{Day}} - (F / \text{PC}_{\text{ENERGYSTAR}}) - (\text{PRE}_{\text{number}} * \text{PRE}_{\text{TimeElecEE}})))$$

$$\text{Preheat Energy}_{\text{ElecEE}} = (\text{PRE}_{\text{number}} * \text{Pre}_{\text{heatEnergyElecEE}})$$

$$\text{Cooking Energy}_{\text{ElecEE}} = (1 / \text{EFF}_{\text{ENERGYSTAR}}) * F * E_{\text{FOOD}}$$

Where:

$\text{CSM}_{\% \text{Baseline}}$  = Baseline Steamer Time in Manual Steam Mode (% of time)  
 = 90%<sup>200</sup>

$\text{IDLE}_{\text{Base}}$  = Idle Energy Rate of Base Steamer<sup>201</sup>

Number of Pans	IDLE <sub>BASE</sub> - Gas, Btu/hr	IDLE <sub>BASE</sub> - Electric, kw
3	11,000	1.0
4	14,667	1.33
5	18,333	1.67
6	22,000	2.0
10	18,000	1.2

$\text{PC}_{\text{Base}}$  = Production Capacity of Base Steamer<sup>202</sup>

Number of Pans	PC <sub>BASE</sub> , gas (lbs/hr)	PC <sub>BASE</sub> , electric (lbs/hr)
3	65	70
4	87	93
5	108	117
6	130	140
10	233	233

<sup>200</sup>Food Service Technology Center 2011 Savings Calculator

<sup>201</sup>Food Service Technology Center 2011 Savings Calculator. Estimates for units with 10 pans taken from ENERGY STAR Commercial Food Service Savings Calculator.

<sup>202</sup>Production capacity per Food Service Technology Center 2011 Savings Calculator of 23.3333 lb/hr per pan for electric baseline steam cookers and 21.6667 lb/hr per pan for natural gas baseline steam cookers. ENERGY STAR<sup>®</sup> savings calculator uses 23.3 lb/hr per pan for both electric and natural gas baseline steamers. Estimates for units with 10 pans taken from ENERGY STAR Commercial Food Service Savings Calculator.

$E_{FOOD}$  = Amount of Energy Absorbed by the food during cooking known as ASTM Energy to Food (Btu/lb or kW/lb)

= 105 Btu/lb (gas steamers) or 0.0308 (electric steamers)<sup>203</sup>

$EFF_{BASE}$  = Heavy Load Cooking Efficiency for Base Steamer

= 15% (gas steamers) or 26% (electric steamers)<sup>204</sup>

$HOURS_{day}$  = Average Daily Operation (hours)

Type of Food Service	Hours <sub>day</sub> <sup>205</sup>
Fast Food, limited menu	4
Fast Food, expanded menu	5
Pizza	8
Full Service, limited menu	8
Full Service, expanded menu	7
Cafeteria	6
Unknown	6 <sup>206</sup>
Custom	Varies

$F$  = Food cooked per day (lbs/day)

= custom or if unknown, use 100 lbs/day<sup>207</sup>

$CSM_{\%ENERGYSTAR}$  = ENERGY STAR Steamer's Time in Manual Steam Mode (% of time)<sup>208</sup>

= 0%

$IDLE_{ENERGYSTAR}$  = Idle Energy Rate of ENERGY STAR<sup>®</sup><sup>209</sup>

= Actual, or

Number of Pans	$IDLE_{ENERGYSTAR} - \text{gas, (Btu/hr)}$	$IDLE_{ENERGYSTAR} - \text{electric, (kW)}$
3	6,250	0.40
4	8,333	0.53
5	10,417	0.67
6	12,500	0.80
10	12,500	0.80

<sup>203</sup>ENERGY STAR Commercial Kitchen Equipment Savings Calculator, Steam Cooker Calculations

<sup>204</sup>Reference Food Service Technology Center 2011 Savings Calculator values as used by Consortium for Energy Efficiency, Inc. for baseline electric and natural gas steamer heavy cooking load energy efficiencies.

<sup>205</sup> Values taken from Minnesota Technical Reference Manual (Version 2.2, effective May 2, 2018), 'Electric Oven and Range' measure and are based upon "Project on Restaurant Energy Performance-End-Use Monitoring and Analysis", Appendixes I and II, Claar, et. al., May 1985.

<sup>206</sup>Unknown is average of other locations

<sup>207</sup>Reference amount used by both Food Service Technology Center and ENERGY STAR<sup>®</sup> savings calculator

<sup>208</sup>Reference information from the Food Service Technology Center citing that ENERGY STAR<sup>®</sup> steamers are not typically operated in constant steam mode, but rather are used in timed mode. Reference ENERGY STAR Commercial Kitchen Equipment Savings Calculator, Steam Cooker Calculation. Both baseline & efficient steamer mode values should be considered for users in Illinois market.

<sup>209</sup>Food Service Technology Center 2011 Savings Calculator. Estimates for units with 10 pans taken from ENERGY STAR Commercial Food Service Savings Calculator.

$PC_{ENERGYSTAR}$  = Production Capacity of ENERGY STAR® Steamer<sup>210</sup>  
 =Actual, or

Number of Pans	$PC_{ENERGY - gas}$ (lbs/hr)	$PC_{ENERGY - electric}$ (lbs/hr)
3	55	50
4	73	67
5	92	83
6	110	100
10	200	167

$EFF_{ENERGYSTAR}$  = Heavy Load Cooking Efficiency for ENERGY STAR® Steamer(%)  
 =Actual, or 38% (gas steamer) or 50% (electric steamer) <sup>211</sup>

$PRE_{number}$  = Number of preheats per day  
 =1<sup>212</sup> (if unknown, use 1)

$PRE_{heatEnergyBase}$  = Energy per preheat of Base Steamer<sup>213</sup>

Equipment Type	Preheat Energy
Electric	1.78 kWh
Gas	18,832.7 Btu

$PRE_{heatEnergyEE}$  = Energy per preheat of ENERGY STAR Steamer<sup>214</sup>

Equipment Type	Preheat Energy
Electric	1.67 kWh
Gas	10,293.9 Btu

$PRE_{TimeBase}$  =Preheat duration of Base Steamer<sup>215</sup>

Equipment Type	Preheat Time (minutes)
Electric	11.9
Gas	10.9

$PRE_{TimeEE}$  = Preheat duration of ENERGY STAR Steamer<sup>216</sup>

Equipment Type	Preheat Time (minutes)
Electric	13.2

<sup>210</sup>Production capacity per Food Service Technology Center 2011 Savings Calculator of 18.3333 lb/hr per pan for gas ENERGY STAR® steam cookers and 16.6667 lb/hr per pan for electric ENERGY STAR® steam cookers. ENERGY STAR® savings calculator uses 16.7 lb/hr per pan for electric and 20 lb/hr for natural gas ENERGY STAR® steamers. Estimates for units with 10 pans taken from ENERGY STAR Commercial Food Service Savings Calculator.

<sup>211</sup>Reference Food Service Technology Center 2011 Savings Calculator values as used by Consortium for Energy Efficiency, Inc. for Tier 1A and Tier 1B qualified electric and natural gas steamer heavy cooking load energy efficiencies, as sourced from ENERGY STAR Program Requirements Product Specification for Commercial Steam Cookers, version 1.2, effective August 1, 2013.

<sup>212</sup>Reference ENERGY STAR Commercial Kitchen Equipment Savings Calculator, Steam Cooker Calculations

<sup>213</sup> Reference ENERGY STAR Commercial Foodservice Savings Calculator, March 2021

<sup>214</sup> Ibid

<sup>215</sup> Ibid

<sup>216</sup> Ibid

Equipment Type	Preheat Time (minutes)
Gas	13.4

- EFF<sub>BASE</sub> = Heavy Load Cooking Efficiency for Base Steamer  
= 15% (gas steamer) or 26% (electric steamer) <sup>217</sup>
- EFF<sub>ENERGYSTAR</sub> = Heavy Load Cooking Efficiency for ENERGY STAR® Steamer  
= Actual, or 38% (gas steamer) or 50% (electric steamer) <sup>218</sup>
- F = Food cooked per day (lbs/day)  
= custom or if unknown, use 100 lbs/day <sup>219</sup>
- E<sub>FOOD</sub> = Amount of Energy Absorbed by the food during cooking known as ASTM Energy to Food <sup>220</sup>

E <sub>FOOD - gas</sub> (Btu/lb)	E <sub>FOOD</sub> (kWh/lb)
105 <sup>221</sup>	0.0308 <sup>222</sup>

Days = days/yr steamer operating (use 365.25 days/yr if heavy use restaurant and exact number unknown)

<sup>217</sup> Reference Food Service Technology Center 2011 Savings Calculator values as used by Consortium for Energy Efficiency, Inc. for baseline electric and natural gas steamer heavy cooking load energy efficiencies.

<sup>218</sup> Ibid.

<sup>219</sup> Amount used by both Food Service Technology Center and ENERGY STAR® savings calculator

<sup>220</sup> Reference ENERGY STAR Commercial Kitchen Equipment Savings Calculator, Steam Cooker Calculations.

<sup>221</sup> Ibid.

<sup>222</sup> Ibid.

**For example**, for an ENERGY STAR gas steam cooker compared to baseline gas cooker: A 3 pan steamer in a full service restaurant

$$\begin{aligned} \Delta\text{Savings} &= (\Delta\text{Idle Energy} + \Delta\text{Preheat Energy} + \Delta\text{Cooking Energy}) * \text{Days} * 1/100.000 \\ \Delta\text{Idle Energy} &= (((1- 0.9)* 11000 + 0.9 * 65 * 105 /0.15 )*(7 - (100 / 65)-(1*0.25))) - (((1-0) * 6250 + \\ &0 * 55 * 105 / 0.38) * (7 - (100 / 55) - (1*0.25)))) \\ &= 188,321 \\ \Delta\text{Preheat Energy} &= (1 *(18,832.7-10,293.9) \\ &= 8,539 \\ \Delta\text{Cooking Energy} &= (((1/ 0.15) - (1/ 0.38)) * (100 lb/day * 105 btu/lb))) \\ &= 42368 \\ \Delta\text{Therms} &= (188321 + 8,539 + 42368) * 365.25 *1/100,000 \\ &= 874 \text{ therms} \end{aligned}$$

For an ENERGY STAR electric steam cooker compared to baseline electric cooker: A 3 pan steamer in a cafeteria:

$$\begin{aligned} \Delta\text{Savings} &= (\Delta\text{Idle Energy} + \Delta\text{Preheat Energy} + \Delta\text{Cooking Energy}) * \text{Days} \\ \Delta\text{Idle Energy} &= (((1- .9)* 1.0 + .9 * 70 * 0.0308 /0.26 )*(6 - (100 / 70)-(1*.25))) - (((1-0) * 0.4 + 0 * \\ &50 * 0.0308 / 0.50) * (6 - (100 / 50) - (1*0.25)))) \\ &= 31.18 \\ \Delta\text{Preheat Energy} &= (1 *(1.78 - 1.67 )) \\ &= 0.1 \\ \Delta\text{Cooking Energy} &= (((1/ 0.26) - (1/ 0.5)) * (100 * 0.0308))) \\ &= 5.69 \\ \Delta\text{kWh} &= (31.18 + 0.1 + 5.69) * 365.25 \text{ days} \\ &= 13,503 \text{ kWh} \end{aligned}$$



For an ENERGY STAR electric steam cooker compared to baseline gas cooker: A 3 pan steamer in a cafeteria:

$$\begin{aligned} \text{SiteEnergySavings (MMBTUs)} &= [\text{GasConsumptionReplaced}] - [\text{ElectricConsumptionAdded}] \\ &= [(\text{Idle Energy}_{\text{GasBase}} + \text{Preheat Energy}_{\text{GasBase}} + \text{Cooking Energy}_{\text{GasBase}}) \\ &\quad * 1/1,000,000 * \text{Days}] - \\ &\quad [(\text{Idle Energy}_{\text{ElecEE}} + \text{Preheat Energy}_{\text{ElecEE}} + \text{Cooking Energy}_{\text{ElecEE}}) * \\ &\quad 3412/1,000,000 * \text{Days}] \end{aligned}$$

$$\begin{aligned} \text{Idle Energy}_{\text{GasBase}} &= (((1- 0.9) * 11000 + 0.9 * 65 * 105 / 0.15 ) * (6 - (100 / 65) - (1 * 0.25))) \\ &= 177,095 \text{ Btu} \end{aligned}$$

$$\begin{aligned} \text{Preheat Energy}_{\text{GasBase}} &= (1 * 18,832) \\ &= 18,832 \text{ Btu} \end{aligned}$$

$$\begin{aligned} \text{Cooking Energy}_{\text{GasBase}} &= (1/ 0.15) * (100 \text{ lb/day} * 105 \text{ btu/lb}) \\ &= 70,000 \end{aligned}$$

$$\begin{aligned} \text{Idle Energy}_{\text{ElecEE}} &= (((1-0) * 0.4 + 0 * 50 * 0.0308 / 0.50) * (6 - (100 / 50) - (1 * 0.25))) \\ &= 1.5 \text{ kWh} \end{aligned}$$

$$\begin{aligned} \text{Preheat Energy}_{\text{ElecEE}} &= (1 * 1.67) \\ &= 1.67 \text{ kWh} \end{aligned}$$

$$\begin{aligned} \text{Cooking Energy}_{\text{ElecEE}} &= (1/ 0.5) * (100 * 0.0308) \\ &= 6.16 \end{aligned}$$

$$\begin{aligned} \text{SiteEnergySavings (MMBTUs)} &= [(177095 + 18,832 + 70,000) * 1/1,000,000 * 365.25] - \\ &= [(1.5 + 1.67 + 6.16) * 3412/1,000,000 * 365.25] \\ &= 86 \text{ MMBtu} \end{aligned}$$

$$\begin{aligned} \text{If supported by an electric utility: } \Delta \text{kWh} &= \Delta \text{SiteEnergySavings} * 1,000,000 / 3,412 \\ &= 86 * 1,000,000/3412 \\ &= 25,205 \text{ kWh} \end{aligned}$$

Secondary kWh Savings for Water Supply and Wastewater Treatment

The following savings should be included in the total savings for this measure, but should not be included in TRC tests to avoid double counting the economic benefit of water savings.

$$\Delta \text{kWh}_{\text{water}} = \Delta \text{Water (gallons)} / 1,000,000 * E_{\text{water supply}}$$

Where

$$\begin{aligned} E_{\text{water supply}} &= \text{IL Supply Energy Factor (kWh/Million Gallons)} \\ &= 2,571^{223} \end{aligned}$$

<sup>223</sup> This factor include 2571 kWh/MG for water supply based on Illinois energy intensity data from a 2012 ISAWWA study. For more information please review Elevate Energy’s ‘IL TRM: Energy per Gallon Factor, May 2018 paper’. Note that the Commercial Steam Cooker does not discharge its water into the wastewater system so only the water supply factor is used here.

**For example**, an electric 3 pan steamer with average efficiency in a full service – expanded menu restaurant

$$\begin{aligned} \Delta\text{Water (gallons)} &= (40 - 10) * 7 * 365.25 \\ &= 76,703 \text{ gallons} \\ \Delta\text{kWh}_{\text{water}} &= 76,703/1,000,000*2,571 \\ &= 197 \text{ kWh} \end{aligned}$$

**SUMMER COINCIDENT PEAK DEMAND SAVINGS**

This is only applicable to the electric steam cooker.

Non-fuel switch measures:

$$\Delta\text{kW} = ((\Delta\text{Idle Energy} + \Delta\text{Preheat Energy} + \Delta\text{Cooking Energy}) / \text{HOURS}_{\text{Day}}) * \text{CF}$$

$$\Delta\text{kW} = - ((\text{Idle Energy}_{\text{ElecEE}} + \text{Preheat Energy}_{\text{ElecEE}} + \text{Cooking Energy}_{\text{ElecEE}}) / \text{HOURS}_{\text{Day}}) * \text{CF}$$

Where:

CF =Summer Peak Coincidence Factor for measure is provided below for different locations:<sup>224</sup>

Location	CF
Fast Food Limited Menu	0.32
Fast Food Expanded Menu	0.41
Pizza	0.46
Full Service Limited Menu	0.51
Full Service Expanded Menu	0.36
Cafeteria	0.39

Other values as defined above

**For example**, for 3 pan electric steam cooker located in a cafeteria:

$$\begin{aligned} \Delta\text{kW} &= ((\Delta\text{Idle Energy} + \Delta\text{Preheat Energy} + \Delta\text{Cooking Energy}) / (\text{HOURS}_{\text{Day}} * \text{Days})) * \text{CF} \\ &= ((31.18 + 0.5 + 5.69)/6) * 0.39 \\ &= 2.43 \text{ kW} \end{aligned}$$

**FOSSIL FUEL SAVINGS**

Calculation provided together with Electric Energy Savings above.

**WATER IMPACT DESCRIPTIONS AND CALCULATION**

This is applicable to both gas and electric steam cookers.

$$\Delta\text{Water (gallons)} = (W_{\text{BASE}} - W_{\text{ENERGYSTAR}}) * \text{HOURS}_{\text{Day}} * \text{Days}$$

<sup>224</sup>Values taken from Minnesota Technical Reference Manual (Version 2.2, effective May 2, 2018), ‘Electric Oven and Range’ measure and are based upon “Project on Restaurant Energy Performance-End-Use Monitoring and Analysis”, Appendixes I and II, Claar, et. al., May 1985.

Where

$W_{BASE}$  = Water Consumption Rate of Base Steamer (gal/hr)  
 = 40<sup>225</sup>

$W_{ENERGYSTAR}$  = Water Consumption Rate of ENERGY STAR® Steamer look up<sup>226</sup>  
 =Actual, or

Equipment Type	gal/hr
Boilerless	1.69
Steam Generation	6.6

**For example**, a boilerless electric 3 pan steamer with in a full service restaurant

$$\Delta\text{Water (gallons)} = (40 - 1.69) * 7 * 365.25$$

$$= 97,949 \text{ gallons}$$

**DEEMED O&M COST ADJUSTMENT CALCULATION**

N/A

**COST EFFECTIVENESS SCREENING AND LOAD REDUCTION FORECASTING WHEN FUEL SWITCHING**

This measure can involve fuel switching from fossil fuel to electric.

For the purposes of forecasting load reductions due to fuel switch projects per Section 16-111.5B, changes in site energy use at the customer’s meter (using  $\Delta\text{kWh}$  algorithm below), customer switching estimates, NTG, and any other adjustment factors deemed appropriate, should be used.

The inputs to cost effectiveness screening should reflect the actual impacts on the electric and fuel consumption at the customer meter and, for fuel switching measures, should therefore reflect the decrease in one fuel and increase in another, as opposed to the single savings value calculated in the “Electric and Fossil Fuel Energy Savings” section above. Therefore in addition to the calculation of savings claimed, the following values should be used to assess the cost effectiveness of the measure.

$$\Delta\text{Therms} = [\text{Gas Cooking Consumption Replaced}]$$

$$= [(\text{Idle Energy}_{\text{GasBase}} + \text{Preheat Energy}_{\text{GasBase}} + \text{Cooking Energy}_{\text{GasBase}}) * 1/100,000 * \text{Days}]$$

$$\Delta\text{kWh} = [\text{Electric Cooking Consumption Added}]$$

$$= - [(\text{Idle Energy}_{\text{ElecEE}} + \text{Preheat Energy}_{\text{ElecEE}} + \text{Cooking Energy}_{\text{ElecEE}}) * \text{Days}]$$

**MEASURE CODE: CI-FSE-STMC-V07-240101**

**REVIEW DEADLINE: 1/1/2028**

<sup>225</sup> FSTC (2002). Commercial Cooking Appliance Technology Assessment. Chapter 8: Steamers.

<sup>226</sup> Average water consumption by equipment type calculated from the ENERGY STAR Qualified Products List, Accessed 06/02/2023.

#### 4.2.4 Conveyor Oven

**DESCRIPTION**

This measure applies to natural gas fired high efficiency conveyor ovens installed in commercial kitchens replacing existing natural gas units with conveyor width greater than 25 inches.

Conveyor ovens are available using four different heating processes: infrared, natural convection with a ceramic baking hearth, forced convection or air impingement, or a combination of infrared and forced convection. Conveyor ovens are typically used for producing a limited number of products with similar cooking requirements at high production rates. They are highly flexible and can be used to bake or roast a wide variety of products including pizza, casseroles, meats, breads, and pastries.

Some manufacturers offer an air-curtain feature at either end of the cooking chamber that helps to keep the heated air inside the conveyor oven. The air curtain operates as a virtual oven wall and helps reduce both the idle energy of the oven and the resultant heat gain to the kitchen.

This measure was developed to be applicable to the following program types: TOS. If applied to other program types, the measure savings should be verified.

**DEFINITION OF EFFICIENT EQUIPMENT**

To qualify for this measure the installed equipment must be a natural gas conveyor oven with a tested baking energy efficiency > 42% and an idle energy consumption rate < 57,000 Btu/hr utilizing ASTM standard F1817.

**DEFINITION OF BASELINE EQUIPMENT**

The baseline equipment is an existing pizza deck oven at end of life.

**DEEMED LIFETIME OF EFFICIENT EQUIPMENT**

The expected measure life is assumed to be 12 years.<sup>227</sup>

**DEEMED MEASURE COST**

The incremental capital cost for this measure is \$2230.<sup>228</sup>

**LOADSHAPE**

N/A

**COINCIDENCE FACTOR**

N/A

---

**Algorithm**

---

**CALCULATION OF SAVINGS**

**ELECTRIC ENERGY SAVINGS**

N/A

**SUMMER COINCIDENT PEAK DEMAND SAVINGS**

N/A

---

<sup>227</sup>See PG&E Workpaper PGECOFST117 Commercial Conveyor Oven – Gas Revision #6, published April 1, 2016..

<sup>228</sup> Ibid.

**FOSSIL FUEL SAVINGS<sup>229</sup>**

$$\Delta\text{Therms} = ((\Delta\text{DailyPreheatEnergy} + \Delta\text{DailyIdleEnergy} + \Delta\text{DailyCookingEnergy}) * \text{Days}) / 100,000$$

Where:

- $\Delta\text{Therms}$  = Annual therms calculated as in the equation above
- Days = Annual days of kitchen operation  
=Actual, if unknown assume 365.25

$$\Delta\text{DailyPreheatEnergy} = (\text{PreheatEnergy}_{\text{Base}} * \text{Preheats}) - (\text{PreheatEnergy}_{\text{EE}} * \text{Preheats})$$

Where:

- $\Delta\text{DailyPreheatEnergy}$  = Energy savings per day when gas conveyor oven is preheating calculated as in the equation above
- $\text{PreheatEnergy}_{\text{Base}}$  = Preheat energy of baseline gas conveyor oven  
= Actual, if unknown use 35,000 Btu
- $\text{PreheatEnergy}_{\text{EE}}$  = Preheat energy of efficient conveyor oven  
= Actual, if unknown use 18,000 Btu
- Preheats = Number of preheats per day  
= Actual, if unknown use 1

$$\Delta\text{DailyIdleEnergy} = (\text{IdleRateGas}_{\text{Base}} * (\text{Hours} - \text{FoodCooked} / \text{ProductionGas}_{\text{Base}} - (\text{Preheats} * \text{PreheatTime} / 60)) - (\text{IdleRateGas}_{\text{EE}} * (\text{Hours} - \text{FoodCooked} / \text{ProductionGas}_{\text{EE}} - (\text{Preheats} * \text{PreheatTime} / 60)))$$

Where:

- $\Delta\text{DailyIdleEnergy}$  = Energy savings per day when gas conveyor oven is idle as calculated in the equation above
- Hours = Average daily hours of operation  
=Actual, if unknown assume 12 hours
- $\text{IdleRateGas}_{\text{Base}}$  = Idle energy rate of baseline gas conveyor oven  
=Actual, if unknown use 70,000 Btu/hr
- $\text{IdleRateGas}_{\text{EE}}$  = Idle energy rate of efficient gas conveyor oven  
=Actual, if unknown use 57,000 Btu/hr
- FoodCooked = Food cooked per day  
= Actual, if unknown use 250 pizzas
- Preheats = Number of preheats per day  
= Actual, if unknown use 1

---

<sup>229</sup> All inputs are taken from PG&E Workpaper PGECOFST117 Commercial Conveyor Oven – Gas Revision #6, published April 1, 2016, unless otherwise referenced.

- PreheatTime = Length of one preheat  
= Actual, if unknown use 15 minutes
- ProductionGas<sub>Base</sub> = Production capacity of baseline gas conveyor oven  
= 150 pizzas per hour
- ProductionGas<sub>EE</sub> = Production capacity of efficient gas conveyor oven  
= Actual, if unknown use 220 pizzas per hour

$$\Delta\text{DailyCookingEnergy} = (\text{FoodCooked} * \text{EFOOD}_{\text{Gas}}/\text{EFF}_{\text{Base}}) - (\text{FoodCooked} * \text{EFOOD}_{\text{Gas}}/\text{EFF}_{\text{EE}})$$

Where:

- $\Delta\text{DailyCookingEnergy}$  = Energy savings per day when gas conveyor oven is cooking
- FoodCooked = Food cooked per day  
= Actual, if unknown use 250 pizzas
- $\text{EFOOD}_{\text{Gas}}$  = ASTM energy to food for gas conveyor oven  
= 190 Btu/pizza
- $\text{EFF}_{\text{Base}}$  = Cooking efficiency of baseline conveyor oven  
= Actual, if unknown use 20%
- $\text{EFF}_{\text{EE}}$  = Cooking efficiency of efficient conveyor oven  
= Actual, if unknown use 42%

**For example**, an efficient conveyor oven compared to baseline conveyor oven using default values from above would save.

$$\Delta\text{Therms} = ((\Delta\text{DailyPreheatEnergy} + \Delta\text{DailyIdleEnergy} + \Delta\text{DailyCookingEnergy}) * \text{Days}) / 100,000$$

Where:

$$\begin{aligned} \Delta\text{DailyPreheatEnergy} &= (35,000 * 1) - (18,000 * 1) \\ &= 17,000 \text{ btu} \\ \Delta\text{DailyIdleEnergy} &= (70,000 * (12 - 250 / 150 - (1 * 15 / 60))) - (57,000 * 12 - 250 / 220 - (1 * 15 / 60)) \\ &= 21,835 \text{ btu} \\ \Delta\text{DailyCookingEnergy} &= (250 * 190 / 0.2) - (250 * 190 / 0.42) \\ = 124,405 \text{ btu} \end{aligned}$$

$$\begin{aligned} \Delta\text{Therms} &= (17,000 + 21,835 + 124,405) * 365.25 / 100000 \\ &= 596 \text{ therms} \end{aligned}$$

#### WATER IMPACT DESCRIPTIONS AND CALCULATION

N/A

**DEEMED O&M COST ADJUSTMENT CALCULATION**

N/A

**MEASURE CODE: CI-FSE-CVOV-V03-240101**

**REVIEW DEADLINE: 1/1/2028**

#### 4.2.5 ENERGY STAR Convection Oven

##### DESCRIPTION

This measure applies to electric or natural gas fired ENERGY STAR convection ovens installed in a commercial kitchen.

Commercial convection ovens that are ENERGY STAR certified have higher heavy load cooking efficiencies, and lower idle energy rates, making them up to 20 percent more efficient than standard models. Energy savings estimates are for ovens using full size (18" x 36") sheet pans.

This measure was developed to be applicable to the following program types: TOS. If applied to other program types, the measure savings should be verified.

##### DEFINITION OF EFFICIENT EQUIPMENT

To qualify for this measure the installed equipment must meet ENERGY STAR requirements listed in ENERGY STAR Commercial Ovens Specifications Version 3.0.

##### DEFINITION OF BASELINE EQUIPMENT

The baseline equipment is a convection oven that is not ENERGY STAR certified and is at end of life.

##### DEEMED LIFETIME OF EFFICIENT EQUIPMENT

The expected measure life is assumed to be 12 years.<sup>230</sup>

##### DEEMED MEASURE COST

The incremental capital cost for this measure uses actual costs, otherwise use costs outlined below:<sup>231</sup>

Equipment Type	Baseline Equipment Cost	Efficient Equipment Cost	Incremental Cost
Electric	\$7,652	\$8,612	\$960
Gas	\$7,510	\$9,884	\$2,374

##### LOADSHAPE

Loadshape C01 - Commercial Electric Cooking

##### COINCIDENCE FACTOR

Summer Peak Coincidence Factor for measure is provided below for different building type:<sup>232</sup>

Location	CF
Fast Food Limited Menu	0.32
Fast Food Expanded Menu	0.41
Pizza	0.46
Full Service Limited Menu	0.51
Full Service Expanded Menu	0.36
Cafeteria	0.39
Unknown	0.41

<sup>230</sup> Lifetime from ENERGY STAR Commercial Kitchen Equipment Savings Calculator, Oven Calculations, which cites reference as "FSTC research on available models, 2009".

<sup>231</sup> Costs sourced from California SWFS001\_Convection\_Oven\_IMC\_Analysis\_-\_2022-07-25

<sup>232</sup> Minnesota Technical Reference Manual, (version 3.2, effective January 7, 2021), Commercial Food Service - Electric Oven and Range, page 481. Unknown is an average of other location types.



**Algorithm**

**CALCULATION OF SAVINGS**

**ELECTRIC ENERGY AND FOSSIL FUEL SAVINGS**

Non Fuel Switch Measures

The algorithm below applies to ENERGY STAR compared to baseline electric convection ovens:

$$\Delta kWh = (\Delta \text{DailyIdle Energy} + \Delta \text{DailyPreheat Energy} + \Delta \text{DailyCooking Energy}) * \text{Days}$$

The algorithm below applies to ENERGY STAR compared to baseline gas convection ovens:

$$\Delta \text{Therms} = (\Delta \text{DailyIdle Energy} + \Delta \text{DailyPreheat Energy} + \Delta \text{DailyCooking Energy}) * \text{Days} / 100,000$$

Fuel Switch/Electrification Measures

Fuel switch / electrification measures must produce positive total energy savings (i.e., reduction in Btus at the premises) in order to qualify. This is determined as follows:

$$\begin{aligned} \text{SiteEnergySavings (MMBTUs)} &= [\text{GasConsumptionReplaced}] - [\text{ElectricConsumptionAdded}] \\ &= [(\text{DailyIdle Energy}_{\text{GasBase}} + \text{DailyPreheat Energy}_{\text{GasBase}} + \text{DailyCooking Energy}_{\text{GasBase}}) * 1/1,000,000 * \text{Days}] - \\ &\quad [(\text{DailyIdle Energy}_{\text{ElecEE}} + \text{DailyPreheat Energy}_{\text{ElecEE}} + \text{DailyCooking Energy}_{\text{ElecEE}}) * 3412/1,000,000 * \text{Days}] \end{aligned}$$

If SiteEnergySavings calculated above is positive, the measure is eligible.

The appropriate savings claim is dependent on which utilities are supporting the measure as provided in a table below:

Measure supported by:	Electric Utility claims (kWh):	Gas Utility claims (therms):
Electric utility only	SiteEnergySavings * 1,000,000/3,412	N/A
Electric and gas utility (Note utilities may make alternative agreements to how savings are allocated as long as total MMBtu savings remains the same).	%IncentiveElectric * SiteEnergySavings * 1,000,000/3,412	%IncentiveGas * SiteEnergySavings * 10
Gas utility only	N/A	SiteEnergySavings * 10

$$\Delta \text{DailyIdleEnergy} = (\text{IdleBase} * \text{IdleBaseTime}) - (\text{IdleENERGYSTAR} * \text{IdleENERGYSTARTime})$$

$$\Delta \text{DailyCookingEnergy} = (\text{LB} * \text{EFOOD} / \text{Eff}_{\text{Base}}) - (\text{LB} * \text{EFOOD} / \text{Eff}_{\text{ENERGYSTAR}})$$

$$\Delta \text{DailyPreheatEnergy} = (\text{PreheatNumber} * \text{PreheatTimeBase} / 60 * \text{PreheatRateBase}) - (\text{PreheatNumber} * \text{PreheatTimeENERGYSTAR} / 60 * \text{PreheatRateENERGYSTAR})$$

$$\text{DailyIdle Energy}_{\text{GasBase}} = (\text{IdleBase}_{\text{Gas}} * \text{IdleBaseTime}_{\text{Gas}})$$

$$\text{DailyCooking Energy}_{\text{GasBase}} = (\text{LB} * \text{EFOOD} / \text{Eff}_{\text{BaseGas}})$$

$$\text{DailyIdle Energy}_{\text{ElecEE}} = (\text{IdleENERGYSTAR}_{\text{Elec}} * \text{IdleENERGYSTARTime})$$

$$\text{DailyCooking Energy}_{\text{ElecEE}} = (\text{LB} * \text{EFOOD} / \text{Eff}_{\text{ENERGYSTAR}_{\text{Elec}}})$$

Where<sup>233</sup>:

IdleENERGYSTAR = Idle energy rate  
 = Actual, if unknown assume:

Oven Type	IdleENERGYSTAR
Electric Half Size	0.8 kW/h
Electric Full-Size ≥ 5 pans	1.2 kW/h
Electric Full-Size < 5 pans	1.0 kW/h
Natural Gas	8,027 Btu/h

IdleBase = Idle energy rate

Oven Type	IdleBASE
Electric Half Size	1.51 kW/h
Electric Full-Size ≥ 5 pans	1.63 kW/h
Electric Full-Size < 5 pans	1.29 kW/h
Natural Gas	12,239 Btu/h

IdleENERGYSTARTime = ENERGY STAR Idle Time (hours)  
 =  $\text{HOURSday} - \text{LB} / \text{PC}_{\text{ENERGYSTAR}} - \text{PreHeatTime}_{\text{ENERGYSTAR}} / 60$

Using defaults:

Oven Type	Calculation	IdleENERGYSTARTime
Electric Half Size	= 12 – 61/42 – 8/60	10.4
Electric Full-Size ≥ 5 pans	= 12 – 122/98 – 9/60	10.6
Electric Full-Size < 5 pans	= 12 – 122/65 – 9/60	10.0
Natural Gas	= 12 – 100/90 – 11/60	10.7

HOURSday = Average Daily Operation  
 = custom or if unknown, use 12 hours

LB = Food cooked per day  
 = custom or if unknown, use 100 pounds for gas oven, 61 lbs for half sized electric oven or 122 lbs for full-sized electric oven<sup>234</sup>. For fuel switching scenarios, use same LB assumption for both baseline and efficient.

PC<sub>ENERGYSTAR</sub> = Production Capacity ENERGY STAR (lb/hr)  
 = Actual, if unknown use:

Oven Type	PC <sub>ENERGYSTAR</sub>
Electric Half Size	42
Electric Full-Size ≥ 5 pans	98
Electric Full-Size < 5 pans	65

<sup>233</sup> All assumptions except where noted are based upon data package provided alongside ENERGY STAR Commercial Ovens Specifications Version 3.0. See ENERGY STAR v3 Commercial Ovens Data Package.xlsx.

<sup>234</sup> Gas default is based upon the ENERGY STAR Commercial Kitchen Calculator. Electric defaults based on data from the Regional Technical Forum for the Northwest Council (Commercial Cooking Convection Oven Calculator, UES Measure Workbook), see “ComCookingConvectionOven\_v4\_0.xlsm”.

Natural Gas	90
-------------	----

PreheatTime<sub>ENERGYSTAR</sub> = preheat length of ENERGY STAR oven  
 = custom or if unknown use<sup>235</sup>:

Oven Type	PreheatTime <sub>ENERGYSTAR</sub>
Electric Half Size	8
Electric Full-Size	9
Natural Gas	11

IdleBaseTime = BASE Idle Time  
 =  $HOURS_{day} - LB / PC_{base} - PreHeatTime_{Base} / 60$

Using defaults:

Oven Type	Calculation	Idle <sub>ENERGYSTAR</sub> Time
Electric Half Size	= $12 - 61/45 - 9/60$	10.5
Electric Full-Size ≥ 5 pans	= $12 - 122/102 - 9/60$	10.7
Electric Full-Size < 5 pans	= $12 - 122/76 - 9/60$	10.2
Natural Gas	= $12 - 100/93 - 12/60$	10.7

PC<sub>Base</sub> = Production Capacity base  
 = Actual, if unknown use:

Oven Type	PC <sub>Base</sub>
Electric Half Size	45
Electric Full-Size ≥ 5 pans	102
Electric Full-Size < 5 pans	76
Natural Gas	93

PreheatTime<sub>Base</sub> = preheat length of base oven  
 = custom or if unknown use<sup>236</sup>:

Oven Type	PreheatTime <sub>Base</sub>
Electric Half Size	9
Electric Full-Size	9
Natural Gas	12

Days = Annual days of operation  
 = custom or if unknown, use 365.25 days a year

E<sub>FOOD</sub> = ASTM energy to food  
 = 0.0732 kWh/lb for electric ovens or 250 btu/pound for natural gas ovens<sup>237</sup>:

Eff<sub>ENERGYSTAR</sub> = Cooking Efficiency ENERGY STAR  
 = Actual, if unknown use:

<sup>235</sup> ENERGY STAR Commercial Kitchen Calculator, updated March 2021.

<sup>236</sup> ENERGY STAR Commercial Kitchen Calculator, updated March 2021.

<sup>237</sup> ENERGY STAR Commercial Kitchen Calculator, updated March 2021.

Oven Type	Eff <sub>ENERGYSTAR</sub>
Electric Half Size	75%
Electric Full-Size ≥ 5 pans	80%
Electric Full-Size < 5 pans	81%
Natural Gas	52%

Eff<sub>Base</sub> = Cooking Efficiency Baseline

Oven Type	Eff <sub>Base</sub>
Electric Half Size	64%
Electric Full-Size ≥ 5 pans	74%
Electric Full-Size < 5 pans	76.5%
Natural Gas	47%

PreheatRate<sub>Base</sub> =Preheat rate (kWh/day for electric units, btu/day for natural gas units) baseline.  
 =Actual, if unknown

Oven Type	PreheatRate <sub>Base</sub>
Electric Half Size	0.89
Electric Full-Size ≥ 5 pans	1.56
Electric Full-Size < 5 pans	1.56
Natural Gas	76,000

PreheatRate<sub>ENERGYSTAR</sub> =Preheat rate (kWh/day for electric units, btu/day for natural gas units) ENERGY STAR.  
 =Actual; or if unknown

Oven Type	PreheatRate <sub>ENERGYSTAR</sub>
Electric Half Size	0.70
Electric Full-Size ≥ 5 pans	1.39
Electric Full-Size < 5 pans	1.39
Natural Gas	44,000

PreheatNumber =Number of preheats per day  
 = Actual; or if unknown use 1

**For example**, an ENERGY STAR gas oven compared to baseline gas oven using default values from above would save.

$$\Delta\text{Therms} = (\Delta\text{Idle Energy} + \Delta\text{Preheat Energy} + \Delta\text{Cooking Energy}) * \text{Days} / 100000$$

Where:

$$\begin{aligned} \Delta\text{DailyIdleEnergy} &= (12,239 * 10.7) - (8,027 * 10.7) \\ &= 45,068 \text{ btu} \end{aligned}$$

$$\begin{aligned} \Delta\text{DailyPreheatEnergy} &= (1 * 12 / 60 * 76,000) - (1 * 12 / 60 * 44,000) \\ &= 6,400 \text{ btu} \end{aligned}$$

$$\begin{aligned} \Delta\text{DailyCookingEnergy} &= (100 * 250 / 0.47) - (100 * 250 / 0.52) \\ &= 5,115 \text{ btu} \end{aligned}$$

$$\begin{aligned} \Delta\text{Therms} &= (45068 + 6,400 + 5115) * 365.25 / 100000 \\ &= 207 \text{ therms} \end{aligned}$$

An ENERGY STAR half sized electric oven compared to baseline electric oven using default values from above would save.

$$\Delta\text{kWh} = (\Delta\text{Idle Energy} + \Delta\text{DailyPreheat Energy} + \Delta\text{Cooking Energy}) * \text{Days} / 100000$$

Where:

$$\begin{aligned} \Delta\text{DailyIdleEnergy} &= (1.51 * 10.5) - (0.8 * 10.4) \\ &= 7.5 \text{ kWh} \end{aligned}$$

$$\begin{aligned} \Delta\text{DailyPreheatEnergy} &= (1 * 9 / 60 * 0.89) - (1 * 9 / 60 * 0.70) \\ &= 0.03 \text{ kWh} \end{aligned}$$

$$\begin{aligned} \Delta\text{DailyCookingEnergy} &= (61 * 0.0732 / 0.64) - (61 * 0.0732 / 0.75) \\ &= 1.02 \text{ kWh} \end{aligned}$$

$$\begin{aligned} \Delta\text{kWh} &= (7.5 + 0.03 + 1.02) * 365.25 \\ &= 3,123 \text{ kWh} \end{aligned}$$

An ENERGY STAR full sized electric oven  $\geq 5$  pans compared to baseline electric oven using default values from above would save.

$$\Delta\text{kWh} = (\Delta\text{Idle Energy} + \Delta\text{DailyPreheat Energy} + \Delta\text{Cooking Energy}) * \text{Days} / 100000$$

Where:

$$\begin{aligned} \Delta\text{DailyIdleEnergy} &= (1.63 * 10.7) - (1.2 * 10.6) \\ &= 4.7 \text{ kWh} \end{aligned}$$

$$\begin{aligned} \Delta\text{DailyPreheatEnergy} &= (1 * 9 / 60 * 1.56) - (1 * 9 / 60 * 1.39) \\ &= 0.03 \text{ kWh} \end{aligned}$$

$$\begin{aligned} \Delta\text{DailyCookingEnergy} &= (122 * 0.0732 / 0.74) - (122 * 0.0732 / 0.80) \\ &= 0.9 \text{ kWh} \end{aligned}$$

$$\begin{aligned} \Delta\text{kWh} &= (4.7 + 0.03 + 0.9) * 365.25 \\ &= 2056 \text{ kWh} \end{aligned}$$

An ENERGY STAR full sized electric oven < 5 pans compared to baseline electric oven using default values from above would save.

$$\Delta kWh = (\Delta Idle Energy + \Delta Cooking Energy) * Days / 100000$$

Where:

$$\begin{aligned} \Delta DailyIdleEnergy &= (1.29 * 10.2) - (1.0 * 10.0) \\ &= 3.2 \text{ kWh} \\ \Delta DailyPreheatEnergy &= (1 * 9 / 60 * 1.56) - (1 * 9 / 60 * 1.39) \\ &= 0.03 \text{ kWh} \\ \Delta DailyCookingEnergy &= (122 * 0.0732 / 0.765) - (122 * 0.0732 / 0.81) \\ &= 0.65 \text{ kWh} \\ \Delta kWh &= (3.2 + 0.03 + 0.65) * 365.25 \\ &= 1,417 \text{ kWh} \end{aligned}$$

An ENERGY STAR full sized >5 pan electric oven compared to baseline gas oven assuming 100 lbs food cooked per day and using other default values from above would save.

$$\begin{aligned} \text{SiteEnergySavings (MMBTUs)} &= [\text{GasConsumptionReplaced}] - [\text{ElectricConsumptionAdded}] \\ &= [(\text{DailyIdle Energy}_{\text{GasBase}} + \text{DailyPreheat Energy}_{\text{GasBase}} + \text{DailyCooking Energy}_{\text{GasBase}}) * 1/1,000,000 * \text{Days}] - \\ &\quad [(\text{DailyIdle Energy}_{\text{ElecEE}} + \text{DailyPreheat Energy}_{\text{ElecEE}} + \text{DailyCooking Energy}_{\text{ElecEE}}) * 3412/1,000,000 * \text{Days}] \end{aligned}$$

$$\begin{aligned} \text{DailyIdleEnergy}_{\text{GasBase}} &= (12,239 * 10.7) \\ &= 130957 \text{ btu} \\ \text{DailyPreheatEnergy}_{\text{GasBase}} &= (1 * 12 / 60 * 76,000) \\ &= 15200 \text{ btu} \\ \text{DailyCookingEnergy}_{\text{GasBase}} &= (100 * 250 / 0.47) \\ &= 53191 \text{ btu} \\ \text{DailyIdleEnergy}_{\text{ElecEE}} &= (1.2 * 10.6) \\ &= 12.7 \text{ kWh} \\ \text{DailyPreheatEnergy}_{\text{ElecEE}} &= (1 * 9 / 60 * 1.39) \\ &= 0.21 \text{ kWh} \\ \text{DailyCookingEnergy}_{\text{ElecEE}} &= (100 * 0.0732 / 0.80) \\ &= 9.2 \text{ kWh} \end{aligned}$$

$$\begin{aligned} \text{SiteEnergySavings (MMBTUs)} &= ((130957 + 15200 + 53191) * 1/1,000,000 * 365.25) - \\ &\quad ((12.7 + 0.21 + 9.2) * 3412/1,000,000 * 365.25) \\ &= 45.3 \text{ MMBtu} \end{aligned}$$

$$\begin{aligned} \text{If supported by an electric utility: } \Delta kWh &= \Delta \text{SiteEnergySavings} * 1,000,000 / 3,412 \\ &= 45.3 * 1,000,000 / 3,412 \\ &= 13,277 \text{ kWh} \end{aligned}$$

**SUMMER COINCIDENT PEAK DEMAND SAVINGS**

Non-fuel switch measures:

$$\Delta kW = ((\Delta \text{DailyIdle Energy} + \Delta \text{DailyPreheat Energy} + \Delta \text{DailyCooking Energy}) / \text{HOURS}_{\text{Day}} * CF$$

Fuel switch measures:

$$\Delta kW = - ((\text{DailyIdle Energy}_{\text{ElecEE}} + \text{DailyPreheat Energy}_{\text{ElecEE}} + \text{DailyCooking Energy}_{\text{ElecEE}}) / \text{HOURS}_{\text{Day}} * CF$$

Where:

CF = Summer Peak Coincidence Factor for measure is provided below for different locations:<sup>238</sup>

Location	CF
Fast Food Limited Menu	0.32
Fast Food Expanded Menu	0.41
Pizza	0.46
Full Service Limited Menu	0.51
Full Service Expanded Menu	0.36
Cafeteria	0.39

Other values as defined above

**FOSSIL FUEL SAVINGS**

Calculation provided together with Electric Energy Savings above.

**WATER IMPACT DESCRIPTIONS AND CALCULATION**

N/A

**DEEMED O&M COST ADJUSTMENT CALCULATION**

N/A

**COST EFFECTIVENESS SCREENING AND LOAD REDUCTION FORECASTING WHEN FUEL SWITCHING**

This measure can involve fuel switching from fossil fuel to electric.

For the purposes of forecasting load reductions due to fuel switch projects per Section 16-111.5B, changes in site energy use at the customer’s meter (using ΔkWh algorithm below), customer switching estimates, NTG, and any other adjustment factors deemed appropriate, should be used.

The inputs to cost effectiveness screening should reflect the actual impacts on the electric and fuel consumption at the customer meter and, for fuel switching measures, should therefore reflect the decrease in one fuel and increase in another, as opposed to the single savings value calculated in the “Electric and Fossil Fuel Energy Savings” section above. Therefore in addition to the calculation of savings claimed, the following values should be used to assess the cost effectiveness of the measure.

<sup>238</sup>Values taken from Minnesota Technical Reference Manual (Version 2.2, effective May 2, 2018), ‘Electric Oven and Range’ measure and are based upon “Project on Restaurant Energy Performance-End-Use Monitoring and Analysis”, Appendixes I and II, Claar, et. al., May 1985.

$$\begin{aligned}\Delta\text{Therms} &= [\text{Gas Cooking Consumption Replaced}] \\ &= [(\text{DailyIdle Energy}_{\text{GasBase}} + \text{DailyPreheat Energy}_{\text{GasBase}} + \text{DailyCooking Energy}_{\text{GasBase}}) * \\ &\quad 1/100,000 * \text{Days}] \\ \Delta\text{kWh} &= [\text{Electric Cooking Consumption Added}] \\ &= - [(\text{DailyIdle Energy}_{\text{ElecEE}} + \text{DailyPreheat Energy}_{\text{ElecEE}} + \text{DailyCooking Energy}_{\text{ElecEE}}) * \text{Days}]\end{aligned}$$

**MEASURE CODE: CI-FSE-ESCV-V05-240101**

**REVIEW DEADLINE: 1/1/2029**



## 4.2.6 ENERGY STAR Dishwasher

### DESCRIPTION

This measure applies to ENERGY STAR high and low temp under counter, stationary single tank door type, single tank conveyor, and multiple tank conveyor dishwashers, as well as high temp pot, pan, and utensil dishwashers installed in a commercial kitchen.

This measure was developed to be applicable to the following program types: TOS. If applied to other program types, the measure savings should be verified.

### DEFINITION OF EFFICIENT EQUIPMENT

To qualify for this measure the installed equipment must be an ENERGY STAR certified dishwasher meeting idle energy rate (kW), washing energy and water consumption (gallons/rack) limits, as determined by both machine type and sanitation approach (chemical/low temp versus high temp).

#### ENERGY STAR Requirements (Version 3.0, effective July 27, 2021)

Dishwasher Type	High Temp Efficiency Requirements			Low Temp Efficiency Requirements		
	Idle Energy Rate	Washing Energy	Water Consumption	Idle Energy Rate	Washing Energy	Water Consumption
Under Counter	≤ 0.30 kW	≤ 0.35 kWh/rack	≤ 0.86 GPR	≤ 0.25 kW	≤ 0.15 kWh/rack	≤ 1.19 GPR
Stationary Single Tank Door	≤ 0.55 kW	≤ 0.35 kWh/rack	≤ 0.89 GPR	≤ 0.30 kW	≤ 0.15 kWh/rack	≤ 1.18 GPR
Pot, Pan, and Utensil	≤ 0.90 kW	≤ 0.55 + 0.05 * SF <sub>rack</sub>	≤ 0.58 GPSF	N/A		
Single Tank Conveyor	≤ 1.20 kW	≤ 0.36 kWh/rack	≤ 0.70 GPR	≤ 0.85 kW	≤ 0.16 kWh/rack	≤ 0.79 GPR
Multiple Tank Conveyor	≤ 1.85 kW	≤ 0.36 kWh/rack	≤ 0.54 GPR	≤ 1.00 kW	≤ 0.22 kWh/rack	≤ 0.54 GPR

### DEFINITION OF BASELINE EQUIPMENT

The baseline equipment is a new dishwasher that is not ENERGY STAR certified.

### DEEMED LIFETIME OF EFFICIENT EQUIPMENT

The expected measure life is assumed to be:<sup>239</sup>

Dishwasher Type		Equipment Life
Low Temp	Under Counter	10
	Stationary Single Tank Door	15
	Single Tank Conveyor	20
	Multi Tank Conveyor	20
High Temp	Under Counter	10
	Stationary Single Tank Door	15
	Single Tank Conveyor	20
	Multi Tank Conveyor	20
	Pot, Pan, and Utensil	10

### DEEMED MEASURE COST

The incremental capital cost for this measure is provided below:<sup>240</sup>

<sup>246</sup>Lifetime from ENERGY STAR Commercial Kitchen Equipment Savings Calculator 03-2021, which cites reference as “FSTC research on available models, 2009.

<sup>246</sup>Lifetime from ENERGY STAR Commercial Kitchen Equipment Savings Calculator 03-2021, which cites reference as “FSTC research on available models, 2009.

Dishwasher Type		Incremental Cost
Low Temp	Under Counter	\$234
	Stationary Single Tank Door	\$662
	Single Tank Conveyor	\$0
	Multi Tank Conveyor	\$970
High Temp	Under Counter	\$2,025
	Stationary Single Tank Door	\$995
	Single Tank Conveyor	\$2,050
	Multi Tank Conveyor	\$970
	Pot, Pan, and Utensil	\$1,710

**LOADSHAPE**

Loadshape C01 - Commercial Electric Cooking

**COINCIDENCE FACTOR**

Summer Peak Coincidence Factor for measure is provided below for different restaurant types:<sup>241</sup>

Location	CF
Fast Food Limited Menu	0.32
Fast Food Expanded Menu	0.41
Pizza	0.46
Full Service Limited Menu	0.51
Full Service Expanded Menu	0.36
Cafeteria	0.39

---

**Algorithm**

---

**CALCULATION OF SAVINGS**

ENERGY STAR dishwashers save energy in three categories: building water heating, booster water heating and idle energy. Building water heating and booster water heating could be either electric or natural gas.

**ELECTRIC ENERGY SAVINGS**

Non-fuel switch measures

Custom calculation below<sup>242</sup>, otherwise use deemed values found within the tables that follow.

$$\Delta kWh = \Delta \text{BuildingEnergy} + \Delta \text{BoosterEnergy} + \Delta \text{IdleEnergy}$$

Where:

$$\begin{aligned} \Delta \text{BuildingEnergy} &= \text{Change in annual electric energy consumption of building water heater} \\ &= [(\text{WaterUse}_{\text{Base}} * \text{RacksWashed} * \text{Days}) * (\Delta T_{\text{in}} * 1.0 * 8.2 \div \text{Eff}_{\text{Heater}} \div 3,412)] - \\ &\quad [(\text{WaterUse}_{\text{ESTAR}} * \text{RacksWashed} * \text{Days}) * (\Delta T_{\text{in}} * 1.0 * 8.2 \div \text{Eff}_{\text{Heater}} \div 3,412)] \end{aligned}$$

<sup>246</sup>Lifetime from ENERGY STAR Commercial Kitchen Equipment Savings Calculator 03-2021, which cites reference as “FSTC research on available models, 2009.

<sup>246</sup>Lifetime from ENERGY STAR Commercial Kitchen Equipment Savings Calculator 03-2021, which cites reference as “FSTC research on available models, 2009.

$$\begin{aligned} \Delta\text{BoosterEnergy} &= \text{Annual electric energy consumption of booster water heater}^{243} \\ &= [(\text{WaterUse}_{\text{Base}} * \text{RacksWashed} * \text{Days}) * (\Delta T_{\text{in}} * 1.0 * 8.2 \div \text{Eff}_{\text{Heater}} \div 3,412)] - \\ &\quad [(\text{WaterUse}_{\text{ESTAR}} * \text{RacksWashed} * \text{Days}) * (\Delta T_{\text{in}} * 1.0 * 8.2 \div \text{Eff}_{\text{Heater}} \div 3,412)] \\ \Delta\text{IdleEnergy} &= \text{Annual idle electric energy consumption of dishwasher} \\ &= [\text{IdleDraw}_{\text{Base}} * (\text{Hours} * \text{Days} - \text{Days} * \text{RacksWashed} * \text{WashTime} \div 60)] - \\ &\quad [\text{IdleDraw}_{\text{ESTAR}} * (\text{Hours} * \text{Days} - \text{Days} * \text{RacksWashed} * \text{WashTime} \div 60)] \end{aligned}$$

Fuel-Switch / Electrification Measures:

Fuel-switching / electrification is only applicable in the following scenario:

Base Case: High Temp Dishwasher with an Electric Booster Heater and a Gas Building Heater

Measure Case: High Temp Heat Recovery Dishwasher with an Electric Booster Heater and no associated Building Heater energy usage.

Fuel-switch / electrification measures must product positive total energy savings (i.e., reduction in Btus at the premises) in order to qualify. The following algorithm can be used to determine eligibility:

$$\begin{aligned} \text{SiteEnergySavings (MMBTUs)} &= [\text{GasConsumptionReplaced} + \text{kWhCosumptionReplaced}] - \\ &\quad [\text{ElectricalConsumptionAdded}] \\ &= [\text{AnnualBuildingEnergy}_{\text{GasBaseTHERMS}} / 10 + \\ &\quad (\text{AnnualBoosterEnergy}_{\text{ElectricBase}} + \text{AnnualIdleEnergy}_{\text{ElectricBase}} + \\ &\quad \text{WaterEnergy}_{\text{GasBase}}) * 3,412 / 1,000,000] - \\ &\quad [(\text{AnnualBoosterEnergy}_{\text{ElectricMeasure}} + \text{AnnualIdleEnergy}_{\text{ElectricMeasure}} + \\ &\quad \text{WaterEnergy}_{\text{ElectricMeasure}}) * 3,412 / 1,000,000] \end{aligned}$$

If SiteEnergySavings calculated above is positive, the measure is eligible.

The appropriate savings claims are dependent on which utilities are supporting the measure as provided in a table below:

Measure supported by:	Electric Utility claims (kWh):	Gas Utility claims (therms):
Electric utility only	SiteEnergySavings * 1,000,000/3,412	N/A
Electric and gas utility <small>(Note utilities may make alternative agreements to how savings are allocated as long as total MMBtu savings remain the same).</small>	%IncentiveElectric * SiteEnergySavings * 1,000,000/3,412	%IncentiveGas * SiteEnergySavings * 10
Gas utility only	N/A	SiteEnergySavings * 10

Where:

WaterUse<sub>Base</sub> = Water use per rack (gal) of baseline dishwasher  
 = Custom or if unknown, use value from table below as determined by machine type and sanitation method

<sup>246</sup>Lifetime from ENERGY STAR Commercial Kitchen Equipment Savings Calculator 03-2021, which cites reference as “FSTC research on available models, 2009.

$WaterUse_{ESTAR}$	= Water use per rack (gal) of ENERGY STAR dishwasher = Custom or if unknown, use value from table below as determined by machine type and sanitation method
RacksWashed	= Number of racks washed per day = Custom or if unknown, use value from table below as determined by machine type and sanitation method
Days	= Annual days of dishwasher operation = Custom or if unknown, use 365.25 days per year
$\Delta T_{in}$	= Inlet water temperature increase (°F) = Custom or if unknown, use 70 °F for building water heaters and 40 °F for booster water heaters  Note for Heat Recovery Dish Washers which accept cold water the temperature increase is 0 °F for building water heaters and 110 °F for booster water heaters.
1.0	= Specific heat of water (Btu/lb/°F)
8.2	= Density of water (lb/gal)
$Eff_{Heater}$	= Efficiency of water heater = Custom or if unknown, use 98% for electric building and booster water heaters
3,412	= kWh to Btu conversion factor
$IdleDraw_{Base}$	= Idle power draw (kW) of baseline dishwasher = Custom or if unknown, use value from table below as determined by machine type and sanitation method
$IdleDraw_{ESTAR}$	= Idle power draw (kW) of ENERGY STAR dishwasher = Custom or if unknown, use value from table below as determined by machine type and sanitation method
Hours	= Average daily hours of dishwasher operation = Custom or if unknown, use 18 hours per day
WashTime	= Typical wash time (min) = Custom or if unknown, use value from table below as determined by machine type and sanitation method
60	= Minutes to hours conversion factor

**For example**, an ENERGY STAR high-temperature, under counter dishwasher with electric building and electric booster water heating with defaults from the calculation above and the table below would save:

$$\Delta kWh = \Delta \text{BuildingEnergy} + \Delta \text{BoosterEnergy} + \Delta \text{IdleEnergy}$$

Where:

$$\begin{aligned} \Delta \text{BuildingEnergy} &= [(1.09 * 75 * 365.25) * (70 * 1.0 * 8.2 \div 0.98 \div 3,412)] - [(0.86 * 75 * 365.25) * (70 * 1.0 * 8.2 \div 0.98 \div 3,412)] \\ &= 1,082 \text{ kWh} \\ \Delta \text{BoosterEnergy} &= [(1.09 * 75 * 365.25) * (40 * 1.0 * 8.2 \div 0.98 \div 3,412)] - [(0.86 * 75 * 365.25) * (40 * 1.0 * 8.2 \div 0.98 \div 3,412)] \\ &= 618 \text{ kWh} \\ \Delta \text{IdleEnergy} &= [0.76 * (18 * 365.25 - 365.25 * 75 * 2.0 \div 60)] - \\ &\quad [0.30 * (18 * 365.25 - 365.25 * 75 * 2.0 \div 60)] \\ &= 2,604 \text{ kWh} \\ \Delta kWh &= 1,082 + 618 + 2,604 \\ &= 4,514 \text{ kWh} \end{aligned}$$

Default values for WaterUse, RacksWashed, kW<sub>Idle</sub>, and WashTime are presented in the table below.

Low Temperature	RacksWashed	WashTime	WaterUse		IdleDraw	
	All Dishwashers	All Dishwashers	Conventional	ENERGY STAR	Conventional	ENERGY STAR
Under Counter	75	2.0	1.73	1.19	0.50	0.25
Stationary Single Tank Door	280	1.5	2.10	1.18	0.60	0.30
Single Tank Conveyor	400	0.3	1.31	0.79	1.60	0.85
Multi Tank Conveyor	600	0.3	1.04	0.54	2.00	1.00
High Temperature	All Dishwashers	All Dishwashers	Conventional	ENERGY STAR	Conventional	ENERGY STAR
Under Counter	75	2.0	1.09	0.86	0.76	0.30
Stationary Single Tank Door	280	1.0	1.29	0.89	0.87	0.55
Single Tank Conveyor	400	0.3	0.87	0.70	1.93	1.20
Multi Tank Conveyor	600	0.2	0.97	0.54	2.59	1.85
Pot, Pan, and Utensil	280	3.0	0.70	0.58	1.20	0.90

Savings for all water heating combinations are presented in the tables below (calculated without rounding variables as provided above).

Electric building and electric booster water heating

Dishwasher type		kWh <sub>Base</sub>	kWh <sub>ESTAR</sub>	ΔkWh
Low Temp	Under Counter	10,972	7,016	3,957
	Stationary Single Tank Door	39,306	21,937	17,369
	Single Tank Conveyor	42,230	24,795	17,434
	Multi Tank Conveyor	50,112	25,809	24,303
High Temp	Under Counter	12,363	8,058	4,305
	Stationary Single Tank Door	39,852	27,250	12,602
	Single Tank Conveyor	45,593	34,621	10,971
	Multi Tank Conveyor	72,523	42,759	29,764
	Pot, Pan, and Utensil	21,079	17,328	3,751

Electric building and natural gas booster water heating

Dishwasher type		kWh <sub>Base</sub>	kWh <sub>ESTAR</sub>	ΔkWh
Low Temp	Under Counter	10,972	7,016	3,957
	Stationary Single Tank Door	39,306	21,937	17,369
	Single Tank Conveyor	42,230	24,795	17,434
	Multi Tank Conveyor	50,112	25,809	24,303
High Temp	Under Counter	9,432	5,746	3,687
	Stationary Single Tank Door	26,901	18,315	8,586
	Single Tank Conveyor	33,115	24,582	8,533
	Multi Tank Conveyor	51,655	31,141	20,513
	Pot, Pan, and Utensil	14,052	11,505	2,547

Natural gas building and electric booster water heating

Dishwasher type		kWh <sub>Base</sub>	kWh <sub>ESTAR</sub>	ΔkWh
Low Temp	Under Counter	2,831	1,415	1,415
	Stationary Single Tank Door	2,411	1,205	1,205
	Single Tank Conveyor	9,350	4,967	4,383
	Multi Tank Conveyor	10,958	5,479	5,479
High Temp	Under Counter	7,234	4,011	3,223
	Stationary Single Tank Door	17,188	11,614	5,574
	Single Tank Conveyor	23,757	17,052	6,704
	Multi Tank Conveyor	36,004	22,429	13,575
	Pot, Pan, and Utensil	8,781	7,138	1,643

Natural gas building and natural gas booster water heating

Dishwasher type		kWh <sub>Base</sub>	kWh <sub>ESTAR</sub>	ΔkWh
Low Temp	Under Counter	2,831	1,415	1,415
	Stationary Single Tank Door	2,411	1,205	1,205
	Single Tank Conveyor	9,350	4,967	4,383
	Multi Tank Conveyor	10,958	5,479	5,479
High Temp	Under Counter	4,303	1,698	2,604
	Stationary Single Tank Door	4,237	2,679	1,558
	Single Tank Conveyor	11,279	7,013	4,266
	Multi Tank Conveyor	15,136	10,811	4,325
	Pot, Pan, and Utensil	1,753	1,315	438

**For example**, the fuel switch measure of a High Temp Heat Recovery Dishwasher with an Electric Booster Heater and no associated Building Heater energy usage, in place of a High Temp Dishwasher with an Electric Booster Heater and a Gas Building Heater.

$$\begin{aligned}
 \text{SiteEnergySavings (MMBTUs)} &= [\text{GasConsumptionReplaced} + \text{kWhConsumptionReplaced}] - \\
 &[\text{ElectricalConsumptionAdded}] \\
 &= [\text{AnnualBuildingEnergy}_{\text{GasBaseTHERMS}} / 10 + \\
 &(\text{AnnualBoosterEnergy}_{\text{ElectricBase}} + \text{AnnualIdleEnergy}_{\text{ElectricBase}} + \\
 &\text{WaterEnergy}_{\text{GasBase}}) * 3,412 / 1,000,000] - \\
 &[(\text{AnnualBoosterEnergy}_{\text{ElectricMeasure}} + \text{AnnualIdleEnergy}_{\text{ElectricMeasure}} + \\
 &\text{WaterEnergy}_{\text{ElectricMeasure}}) * 3,412 / 1,000,000] \\
 \\
 \text{AnnualBuildingEnergy}_{\text{GasBaseTHERMS}} &= (\text{WaterUse}_{\text{Base}} * \text{RacksWashed} * \text{Days}) * (\Delta T_{\text{in}} * 1.0 * 8.2 \div \text{Eff}_{\text{Heater}} \\
 &\div 100,000) \\
 &= (1.09 * 75 * 365.25) * (70 * 1 * 8.2 / 0.8 / 100,000) \\
 &= 214 \text{ Therm} \\
 \\
 \text{AnnualBoosterEnergy}_{\text{ElectricBase}} &= (\text{WaterUse}_{\text{Base}} * \text{RacksWashed} * \text{Days}) * (\Delta T_{\text{in}} * 1.0 * 8.2 \div \text{Eff}_{\text{Heater}} \\
 &\div 3,412) \\
 &= (1.09 * 75 * 365.25) * (40 * 1 * 8.2 / 0.98 / 3,412) \\
 &= 2,929 \text{ kWh} \\
 \\
 \text{AnnualIdleEnergy}_{\text{ElectricBase}} &= \text{IdleDraw}_{\text{Base}} * (\text{Hours} * \text{Days} - \text{Days} * \text{RacksWashed} * \text{WashTime} \\
 &\div 60) \\
 &= 0.76 * (18 * 365.25 - 365.25 * 75 * 2 / 60) \\
 &= 4,303 \text{ kWh} \\
 \\
 \text{WaterEnergy}_{\text{ElectricBase}} &= (\text{WaterUse}_{\text{Base}} * \text{RacksWashed} * \text{Days}) / 1,000,000 * 5,010 \\
 &= (0.86 * 75 * 365.25) / 1,000,000 * 5,010 \\
 &= 150 \text{ kWh} \\
 \\
 \text{AnnualBoosterEnergy}_{\text{ElectricMeasure}} &= (\text{WaterUse}_{\text{Measure}} * \text{RacksWashed} * \text{Days}) * (\Delta T_{\text{in}} * 1.0 * 8.2 \div \\
 &\text{Eff}_{\text{Heater}} \div 3,412) \\
 &= (0.86 * 75 * 365.25) * (110 * 1 * 8.2 / 0.98 / 3,412) \\
 &= 6,355 \text{ kWh} \\
 \\
 \text{AnnualIdleEnergy}_{\text{ElectricMeasure}} &= \text{IdleDraw}_{\text{Measure}} * (\text{Hours} * \text{Days} - \text{Days} * \text{RacksWashed} * \\
 &\text{WashTime} \div 60) \\
 &= 0.3 * (18 * 365.25 - 365.25 * 75 * 2 / 60) \\
 &= 1,698 \text{ kWh} \\
 \\
 \text{WaterEnergy}_{\text{ElectricMeasure}} &= (\text{WaterUse}_{\text{Measure}} * \text{RacksWashed} * \text{Days}) / 1,000,000 * 5,010 \\
 &= (0.86 * 75 * 365.25) / 1,000,000 * 5,010 \\
 &= 118 \text{ kWh} \\
 \\
 \text{SiteEnergySavings (MMBTUs)} &= [214 / 10 + (2,929 + 4,303 + 150) * 3,412 / 1,000,000] - [(6,355 + \\
 &1,698 + 118) * 3,412 / 1,000,000] \\
 &= 18.7 \text{ MMBTU} \\
 \\
 \text{If supported by an electric utility} &= \text{SiteEnergySavings} * 1,000,000 / 3,412 \\
 &= 18.7 * 1,000,000 / 3,412 \\
 &= 5,481 \text{ kWh}
 \end{aligned}$$

Secondary kWh Savings for Water Supply and Wastewater Treatment

The following savings should be included in the total savings for this measure, but should not be included in TRC tests to avoid double counting the economic benefit of water savings.

$$\Delta kWh_{water} = \Delta Water \text{ (gallons)} / 1,000,000 * E_{water \text{ total}}$$

Where

$$E_{water \text{ total}} = \text{IL Total Water Energy Factor (kWh/Million Gallons)}$$

$$= 5,010^{244}$$

**For example**, an ENERGY STAR low-temperature, under-counter dishwasher with defaults from the calculation above and the table within the electric energy savings characterization would save:

$$\Delta Water = (WaterUse_{Base} * RacksWashed * Days) - (WaterUse_{ESTAR} * RacksWashed * Days)$$

$$\Delta Water \text{ (gallons)} = (1.73 * 75 * 365.25) - (1.19 * 75 * 365.25)$$

$$= 14,793 \text{ gallons}$$

$$\Delta kWh_{water} = 14,793 / 1,000,000 * 5,010$$

$$= 74 \text{ kWh}$$

**SUMMER COINCIDENT PEAK DEMAND SAVINGS**

$$\Delta kW = \Delta kWh / \text{AnnualHours} * CF$$

Where:

$\Delta kWh$  = Annual kWh savings from measure as calculated above. Note: do not include the secondary savings in this calculation.

$\text{AnnualHours}$  = Hours \* Days  
 = Custom, or if unknown assume (18 \* 365.25 =) 6575 annual hours

$CF$  = Summer Peak Coincidence Factor  
 = dependent on restaurant type:<sup>245</sup>

Location	CF
Fast Food Limited Menu	0.32
Fast Food Expanded Menu	0.41
Pizza	0.46
Full Service Limited Menu	0.51
Full Service Expanded Menu	0.36
Cafeteria	0.39

<sup>246</sup>Lifetime from ENERGY STAR Commercial Kitchen Equipment Savings Calculator 03-2021, which cites reference as “FSTC research on available models, 2009.

<sup>246</sup>Lifetime from ENERGY STAR Commercial Kitchen Equipment Savings Calculator 03-2021, which cites reference as “FSTC research on available models, 2009.



**For example**, a low temperature undercounter dishwasher in a Full Service Limited Menu restaurant with electric building and booster water heaters would save:

$$\begin{aligned} \Delta kW &= \Delta kWh / \text{AnnualHours} * CF \\ &= 3957 / 6575 * 0.51 \\ &= 0.307 \text{ kW} \end{aligned}$$

**FOSSIL FUEL SAVINGS**

$$\Delta \text{Therms} = \Delta \text{BuildingEnergy} + \Delta \text{BoosterEnergy}$$

Where:

$$\begin{aligned} \Delta \text{BuildingEnergy} &= \text{Change in annual natural gas consumption of building water heater} \\ &= [(\text{WaterUse}_{\text{Base}} * \text{RacksWashed} * \text{Days}) * (\Delta T_{\text{in}} * 1.0 * 8.2 \div \text{Eff}_{\text{Heater}} \div 100,000)] - \\ &\quad [(\text{WaterUse}_{\text{ESTAR}} * \text{RacksWashed} * \text{Days}) * (\Delta T_{\text{in}} * 1.0 * 8.2 \div \text{Eff}_{\text{Heater}} \div 100,000)] \end{aligned}$$

$$\begin{aligned} \Delta \text{BoosterEnergy} &= \text{Change in annual natural gas consumption of booster water heater} \\ &= [(\text{WaterUse}_{\text{Base}} * \text{RacksWashed} * \text{Days}) * (\Delta T_{\text{in}} * 1.0 * 8.2 \div \text{Eff}_{\text{Heater}} \div 100,000)] - \\ &\quad [(\text{WaterUse}_{\text{ESTAR}} * \text{RacksWashed} * \text{Days}) * (\Delta T_{\text{in}} * 1.0 * 8.2 \div \text{Eff}_{\text{Heater}} \div 100,000)] \end{aligned}$$

Where:

$\text{WaterUse}_{\text{Base}}$  = Water use per rack (gal) of baseline dishwasher  
 = Custom or if unknown, use value from table within the electric energy savings characterization as determined by machine type and sanitation method

$\text{WaterUse}_{\text{ESTAR}}$  = Water use per rack (gal) of ENERGY STAR dishwasher  
 = Custom or if unknown, use value from table within the electric energy savings characterization as determined by machine type and sanitation method

$\text{RacksWashed}$  = Number of racks washed per day  
 = Custom or if unknown, use value from table within the electric energy savings characterization as determined by machine type and sanitation method

$\text{Days}$  = Annual days of dishwasher operation  
 = Custom or if unknown, use 365 days per year

$\Delta T_{\text{in}}$  = Inlet water temperature increase (°F)  
 = Custom or if unknown, use 70 °F for building water heaters and 40 °F for booster water heaters

1.0 = Specific heat of water (Btu/lb/°F)

8.2 = Density of water (lb/gal)

$\text{Eff}_{\text{Heater}}$  = Efficiency of water heater  
 = Custom or 80% for gas building and booster water heaters

100,000 = Therms to Btu conversion factor

**For example**, an ENERGY STAR high-temperature, under counter dishwasher with gas building and gas booster water heating with defaults from the calculation above and the table within the electric energy savings characterization would save:

$$\Delta\text{Therms} = \Delta\text{BuildingEnergy} + \Delta\text{BoosterEnergy}$$

Where:

$$\begin{aligned} \Delta\text{BuildingEnergy} &= [(1.09 * 75 * 365.25) * (70 * 1.0 * 8.2 \div 0.80 \div 100,000)] - [(0.86 * 75 * 365.25) * (70 * 1.0 * 8.2 \div 0.80 \div 100,000)] \\ &= 45 \text{ therms} \\ \Delta\text{BoosterEnergy} &= [(1.09 * 75 * 365.25) * (40 * 1.0 * 8.2 \div 0.80 \div 100,000)] - [(0.86 * 75 * 365.25) * (40 * 1.0 * 8.2 \div 0.80 \div 100,000)] \\ &= 26 \text{ therms} \\ \Delta\text{Therms} &= 45 + 26 \\ &= 71 \text{ therms} \end{aligned}$$

Savings for all water heating combinations are presented in the tables below.

Electric building and natural gas booster water heating

Dishwasher type		Therms <sub>Base</sub>	Therms <sub>ESTAR</sub>	ΔTherms
Low Temp	Under Counter	NA	NA	NA
	Stationary Single Tank Door	NA	NA	NA
	Single Tank Conveyor	NA	NA	NA
	Multi Tank Conveyor	NA	NA	NA
High Temp	Under Counter	123	97	26
	Stationary Single Tank Door	541	374	168
	Single Tank Conveyor	522	420	102
	Stationary Single Tank Door	872	486	387
	Pot, Pan, and Utensil	294	243	50

Natural gas building and natural gas booster water heating

Dishwasher type		Therms <sub>Base</sub>	Therms <sub>ESTAR</sub>	ΔTherms
Low Temp	Under Counter	340	234	106
	Stationary Single Tank Door	1,543	867	676
	Single Tank Conveyor	1,375	829	546
	Multi Tank Conveyor	1,637	850	787
High Temp	Under Counter	337	266	71
	Stationary Single Tank Door	1,489	1,027	462
	Single Tank Conveyor	1,435	1,154	280
	Multi Tank Conveyor	2,399	1,336	1,064
	Pot, Pan, and Utensil	808	669	139

Natural gas building and electric booster water heating

Dishwasher type		Therms <sub>Base</sub>	Therms <sub>ESTAR</sub>	ΔTherms
Low Temp	Under Counter	340	234	106
	Stationary Single Tank Door	1,543	867	676
	Single Tank Conveyor	1,375	829	546
	Multi Tank Conveyor	1,637	850	787
High Temp	Under Counter	214	169	45

Dishwasher type		Therms <sub>Base</sub>	Therms <sub>ESTAR</sub>	ΔTherms
High Temp	Stationary Single Tank Door	948	654	294
	Single Tank Conveyor	913	735	178
	Multi Tank Conveyor	1,527	850	677
	Pot, Pan, and Utensil	514	426	88

**WATER IMPACT DESCRIPTIONS AND CALCULATION**

$$\Delta\text{Water} = (\text{WaterUse}_{\text{Base}} * \text{RacksWashed} * \text{Days}) - (\text{WaterUse}_{\text{ESTAR}} * \text{RacksWashed} * \text{Days})$$

Where:

- WaterUse<sub>Base</sub> = Water use per rack (gal) of baseline dishwasher  
= Custom or if unknown, use value from table within the electric energy savings characterization as determined by machine type and sanitation method
- WaterUse<sub>ESTAR</sub> = Water use per rack (gal) of ENERGY STAR dishwasher  
= Custom or if unknown, use value from table within the electric energy savings characterization as determined by machine type and sanitation method
- RacksWashed = Number of racks washed per day  
= Custom or if unknown, use value from table within the electric energy savings characterization as determined by machine type and sanitation method
- Days = Annual days of dishwasher operation  
= Custom or if unknown, use 365 days per year

**For example**, an ENERGY STAR low-temperature, under counter dishwasher with defaults from the calculation above and the table within the electric energy savings characterization would save:

$$\Delta\text{Water} = (\text{WaterUse}_{\text{Base}} * \text{RacksWashed} * \text{Days}) - (\text{WaterUse}_{\text{ESTAR}} * \text{RacksWashed} * \text{Days})$$

$$\Delta\text{Water (gallons)} = (1.73 * 75 * 365.25) - (1.19 * 75 * 365.25)$$

$$= 14,793 \text{ gallons}$$

Savings for all dishwasher types are presented in the table below.

	Annual Water Consumption (gallons)		
	Baseline	ENERGY STAR	Savings
<b>Low Temperature</b>			
Under Counter	47,391	32,599	14,793
Stationary Single Tank Door	214,767	120,679	94,088
Single Tank Conveyor	191,391	115,419	75,972
Multi Tank Conveyor	227,916	118,341	109,575
<b>High Temperature</b>			
Under Counter	29,859	23,559	6,301
Stationary Single Tank Door	131,928	91,020	40,908
Single Tank Conveyor	127,107	102,270	24,837
Multi Tank Conveyor	212,576	118,341	94,235
Pot, Pan, and Utensil	71,589	59,317	12,272

**DEEMED O&M COST ADJUSTMENT CALCULATION**

N/A

**COST EFFECTIVENESS SCREENING AND LOAD REDUCTION FORECASTING WHEN FUEL SWITCHING**

This measure can involve fuel switching from fossil fuel to electric.

For the purposes of forecasting load reductions due to fuel switch projects per Section 16-111.5B, changes in site energy use at the customer’s meter (using ΔkWh algorithm below), customer switching estimates, NTG, and any other adjustment factors deemed appropriate, should be used.

The inputs to cost effectiveness screening should reflect the actual impacts on the electric and fuel consumption at the customer meter and, for fuel switching measures, should therefore reflect the decrease in one fuel and increase in another, as opposed to the single savings value calculated in the “Electric and Fossil Fuel Energy Savings” section above. Therefore in addition to the calculation of savings claimed, the following values should be used to assess the cost effectiveness of the measure.

$$\begin{aligned} \Delta\text{Therms} &= [\text{Gas Consumption Replaced}] \\ &= [((\text{WaterUse}_{\text{Base}} * \text{RacksWashed} * \text{Days}) * (\Delta T_{\text{in}} * 1.0 * 8.2 / \text{Eff}_{\text{Heater}} / 100,000)) + \\ &\quad ((\text{WaterUse}_{\text{Base}} * \text{RacksWashed} * \text{Days}) * (\Delta T_{\text{in}} * 1.0 * 8.2 / \text{Eff}_{\text{Heater}} / 100,000))] \\ \Delta\text{kWh} &= [\text{Electric Consumption Added}] \\ &= - [(((\text{WaterUse}_{\text{ESTAR}} * \text{RacksWashed} * \text{Days}) * (\Delta T_{\text{in}} * 1.0 * 8.2 / \text{Eff}_{\text{Heater}} / 3,412)) + \\ &\quad (((\text{WaterUse}_{\text{ESTAR}} * \text{RacksWashed} * \text{Days}) * (\Delta T_{\text{in}} * 1.0 * 8.2 / \text{Eff}_{\text{Heater}} / 3,412))) + \\ &\quad ((\text{IdleDraw}_{\text{ESTAR}} * (\text{Hours} * \text{Days} - \text{Days} * \text{RacksWashed} * \text{WashTime} / 60))))] \end{aligned}$$

**MEASURE CODE: CI-FSE-ESDW-V07-240101**

**REVIEW DEADLINE: 1/1/2026**

## 4.2.7 ENERGY STAR Fryer

### DESCRIPTION

This measure applies to electric or natural gas fired ENERGY STAR certified fryers installed in a commercial kitchen.

This measure was developed to be applicable to the following program types: TOS. If applied to other program types, the measure savings should be verified.

### DEFINITION OF EFFICIENT EQUIPMENT

To qualify for this measure, the installed equipment must be an ENERGY STAR certified fryer meeting idle energy rate (W or Btu/hr) and cooking efficiency (%) limits, as determined by both fuel type and fryer capacity (standard versus large vat).

### ENERGY STAR Requirements (Version 3.0, Effective October 1, 2016)

Fryer Capacity	Electric Efficiency Requirements		Natural Gas Efficiency Requirements	
	Idle Energy Rate	Cooking Efficiency Consumption	Idle Energy Rate	Cooking Efficiency Consumption
Standard Open Deep-Fat Fryer	≤ 800 W	≥ 83%	≤ 9,000 Btu/hr	≥ 50%
Large Vat Open Deep-Fat Fryer	≤ 1,100 W	≥ 80%	≤ 12,000 Btu/hr	

### DEFINITION OF BASELINE EQUIPMENT

The baseline equipment is a new electric or natural gas fryer that is not ENERGY STAR certified.

### DEEMED LIFETIME OF EFFICIENT EQUIPMENT

The expected measure life is assumed to be 12 years.<sup>246</sup>

### DEEMED MEASURE COST

For the incremental capital costs, please see the table below:<sup>247</sup>

Fuel Source	Size	Incremental Cost
Electric	Standard	\$1,500
	Large Vat	\$500
Natural Gas	Standard	\$1,000
	Large Vat	\$2,000

### LOADSHAPE

Loadshape C01 - Commercial Electric Cooking

<sup>246</sup>Lifetime from ENERGY STAR Commercial Kitchen Equipment Savings Calculator 03-2021, which cites reference as “FSTC research on available models, 2009.

<sup>247</sup>Measure cost from ENERGY STAR Commercial Kitchen Equipment Savings Calculator (last updated March 2021) which cites reference as “Difference between a similar ENERGY STAR and non-qualifying model, EPA research using AutoQuotes, October 2020”.

**COINCIDENCE FACTOR**

Summer Peak Coincidence Factor for measure is provided below for different building type:<sup>248</sup>

Location	CF
Fast Food Limited Menu	0.32
Fast Food Expanded Menu	0.41
Pizza	0.46
Full Service Limited Menu	0.51
Full Service Expanded Menu	0.36
Cafeteria	0.39

---

**Algorithm**

---

**CALCULATION OF SAVINGS**

**ELECTRIC AND FOSSIL FUEL ENERGY SAVINGS**

Non Fuel Switch Measures

The algorithm below applies to ENERGY STAR compared to baseline electric fryer:

$$\Delta kWh = (\Delta DailyIdleEnergy + \Delta DailyPreheatEnergy + \Delta DailyCookingEnergy) * Days / 1,000$$

The algorithm below applies to ENERGY STAR compared to baseline gas fryer:

$$\Delta Therms = (\Delta DailyIdleEnergy + \Delta DailyPreheatEnergy + \Delta DailyCookingEnergy) * Days / 100,000$$

Fuel Switch/Electrification Measures:

Fuel switch / electrification measures must produce positive total energy savings (i.e., reduction in Btus at the premises) in order to qualify. This is determined as follows:

$$\begin{aligned} \text{SiteEnergySavings (MMBTUs)} &= [\text{GasConsumptionReplaced}] - [\text{ElectricConsumptionAdded}] \\ &= [(\text{DailyIdleEnergy}_{\text{GasBase}} + \text{DailyPreheatEnergy}_{\text{GasBase}} + \text{DailyCookingEnergy}_{\text{GasBase}}) * 1/1,000,000 * \text{Days}] - \\ &\quad [(\text{DailyIdleEnergy}_{\text{ElecEE}} + \text{DailyPreheatEnergy}_{\text{ElecEE}} + \text{DailyCookingEnergy}_{\text{ElecEE}}) * 3.412/1,000,000 * \text{Days}] \end{aligned}$$

If SiteEnergySavings calculated above is positive, the measure is eligible.

The appropriate savings claim is dependent on which utilities are supporting the measure as provided in a table below:

Measure supported by:	Electric Utility claims (kWh):	Gas Utility claims (therms):
Electric utility only	SiteEnergySavings * 1,000,000/3,412	N/A

<sup>248</sup>Values taken from Minnesota Technical Reference Manual, (Version 2.2, effective May 2, 2018), ‘Electric Oven and Range’ measure and are based upon “Project on Restaurant Energy Performance-End-Use Monitoring and Analysis”, Appendixes I and II, Claar, et. al., May 1985.

Measure supported by:	Electric Utility claims (kWh):	Gas Utility claims (therms):
Electric and gas utility (Note utilities may make alternative agreements to how savings are allocated as long as total MMBtu savings remains the same).	%IncentiveElectric * SiteEnergySavings * 1,000,000/3,412	%IncentiveGas * SiteEnergySavings * 10
Gas utility only	N/A	SiteEnergySavings * 10

$$\Delta\text{DailyIdleEnergy} = (\text{Idle}_{\text{Base}} * ((\text{HOURS} - (\text{PreheatTime}/60)) - \text{LB}/\text{PC}_{\text{Base}})) - (\text{Idle}_{\text{ESTAR}} * ((\text{HOURS} - (\text{PreheatTime}/60)) - \text{LB}/\text{PC}_{\text{ESTAR}}))$$

$$\Delta\text{DailyPreheatEnergy} = (\text{PreheatEnergy}_{\text{Base}} - \text{PreheatEnergy}_{\text{ESTAR}}) * 1,000$$

$$\Delta\text{DailyCookingEnergy} = (\text{LB} * \text{EFOOD}/\text{Eff}_{\text{Base}}) - (\text{LB} * \text{EFOOD}/\text{Eff}_{\text{ESTAR}})$$

$$\text{DailyIdle Energy}_{\text{GasBase}} = (\text{Idle}_{\text{BaseGas}} * ((\text{HOURS} - (\text{PreheatTime}/60)) - \text{LB}/\text{PC}_{\text{BaseGas}}))$$

$$\text{DailyCooking Energy}_{\text{GasBase}} = (\text{LB} * \text{EFOOD}/\text{Eff}_{\text{BaseGas}})$$

$$\text{DailyIdle Energy}_{\text{ElecEE}} = (\text{Idle}_{\text{ESTARElec}} * ((\text{HOURS} - (\text{PreheatTime}/60)) - \text{LB}/\text{PC}_{\text{ESTARElec}}))$$

$$\text{DailyCooking Energy}_{\text{ElecEE}} = (\text{LB} * \text{EFOOD}/\text{Eff}_{\text{ESTAR}})$$

Where<sup>249</sup>:

$\text{Idle}_{\text{Base}}$  = Idle energy rate of baseline fryer

Fryer Type	$\text{Idle}_{\text{Base}}$
Electric Standard	1,200 W/h
Electric Large Vat	1,350 W/h
Natural Gas Standard	14,000 Btu/h
Natural Gas Large Vat	16,000 Btu/h

$\text{Idle}_{\text{ESTAR}}$  = Idle energy rate of ENERGY STAR electric fryer

= Actual, if unknown use:

Fryer Type	$\text{Idle}_{\text{ESTAR}}$
Electric Standard	800 W/h
Electric Large Vat	1,100 W/h
Natural Gas Standard	9,000 Btu/h
Natural Gas Large Vat	12,000 Btu/h

HOURS = Average daily hours of operation

= Actual or if unknown, use 16 hours per day for a standard fryer and 12 hours per day for a large vat fryer

PreheatTime = Time required to preheat the fryer

= 15 minutes per day

<sup>249</sup> Algorithms and assumptions derived from ENERGY STAR Commercial Kitchen Equipment Savings Calculator (last updated March 2021).

- 60 = minutes to hours conversion factor
- LB = Food cooked per day
- = Actual or if unknown, use 150 pounds
- PC<sub>Base</sub> = Production capacity of baseline fryer (lb/h)

Fryer Type	PC <sub>Base</sub> (lb/h)
Electric Standard	65
Electric Large Vat	100
Natural Gas Standard	60
Natural Gas Large Vat	100

- PC<sub>ESTAR</sub> = Production capacity of ENERGY STAR fryer
- = Actual or if unknown, use

Fryer Type	PC <sub>Base</sub> (lb/h)
Electric Standard	70
Electric Large Vat	110
Natural Gas Standard	65
Natural Gas Large Vat	110

- PreheatEnergy<sub>Base</sub> = Total energy used during preheat of baseline fryer
- = 2.4 kWh for electric fryers and 18,500Btu for gas fryers
- PreheatEnergy<sub>ESTAR</sub> = Total energy used during preheat of ENERGY STAR fryer
- = Actual, or if unknown assume 1.9 kWh for electric fryers and 16,000Btu for gas fryers

- EFOOD = ASTM energy to food
- = 167 Wh/lb for electric fryers and 570 Btu/lb for gas fryers

- Eff<sub>Base</sub> = Cooking efficiency of baseline electric fryer

Fryer Type	Eff <sub>Base</sub>
Electric Standard	75%
Electric Large Vat	70%
Natural Gas Standard	35%
Natural Gas Large Vat	35%

- Eff<sub>ESTAR</sub> = Cooking efficiency of ENERGY STAR electric fryer
- = Actual or if unknown use:

Fryer Type	Eff <sub>ESTAR</sub>
Electric Standard	83%
Electric Large Vat	80%
Natural Gas Standard	50%
Natural Gas Large Vat	50%

- Days = Annual days of operation



- 1,000 = Custom, or if unknown, use 365.25 days per year
- 100,000 = Wh to kWh conversion factor
- 100,000 = Btu to therms conversion factor

**For example**, an ENERGY STAR standard-sized electric fryer, using default values from the calculation above, would save:

$$\Delta\text{kWh} = (\Delta\text{DailyIdleEnergy} + \Delta\text{DailyPreheatEnergy} + \Delta\text{DailyCookingEnergy}) * \text{Days} / 1,000$$

Where:

$$\begin{aligned} \Delta\text{DailyIdleEnergy} &= (1,200 * ((16 - 15/60) - 150 / 65)) - (800 * ((16 - 15/60) - 150 / 70)) \\ &= 5,245 \text{ Wh} \end{aligned}$$

$$\begin{aligned} \Delta\text{DailyPreheatEnergy} &= (2.4 - 1.9) * 1,000 \\ &= 500 \text{ Wh} \end{aligned}$$

$$\begin{aligned} \Delta\text{DailyCookingEnergy} &= (150 * 167 / 0.75) - (150 * 167 / 0.83) \\ &= 3,219 \text{ Wh} \end{aligned}$$

$$\begin{aligned} \Delta\text{kWh} &= (5,245 + 500 + 3,219) * 365.25 / 1,000 \\ &= 3,274.2 \text{ kWh} \end{aligned}$$

$$[\text{Electric Large Vat using defaults} = 2,697.6 \text{ kWh}]$$

**For example**, an ENERGY STAR standard-sized gas fryer, using default values from the calculation above, would save:

$$\Delta\text{Therms} = (\Delta\text{DailyIdleEnergy} + \Delta\text{DailyPreheatEnergy} + \Delta\text{DailyCookingEnergy}) * \text{Days} / 100,000$$

Where:

$$\begin{aligned} \Delta\text{DailyIdleEnergy} &= (14,000 * ((16 - 15/60) - 150 / 60)) - (9,000 * ((16 - 15/60) - 150 / 65)) \\ &= 64,519 \text{ Btu/day} \end{aligned}$$

$$\begin{aligned} \Delta\text{DailyPreheatEnergy} &= 18,500 - 16,000 \\ &= 2,500 \text{ Btu/day} \end{aligned}$$

$$\begin{aligned} \Delta\text{DailyCookingEnergy} &= (150 * 570 / 0.35) - (150 * 570 / 0.50) \\ &= 73,286 \text{ Btu/day} \end{aligned}$$

$$\begin{aligned} \Delta\text{Therms} &= (64,519 + 2,500 + 73,286) * 365.25 / 100,000 \\ &= 512.5 \text{ therms} \end{aligned}$$

$$[\text{Gas Large Vat using defaults} = 420.6 \text{ therms}]$$

An ENERGY STAR standard-sized electric fryer compared to baseline gas fryer assuming default values from above would save.

$$\begin{aligned} \text{SiteEnergySavings (MMBTUs)} &= [\text{GasConsumptionReplaced}] - [\text{ElectricConsumptionAdded}] \\ &= [(\text{DailyIdleEnergy}_{\text{GasBase}} + \text{DailyPreheatEnergy}_{\text{GasBase}} + \\ &\quad \text{DailyCookingEnergy}_{\text{GasBase}}) * 1/1,000,000 * \text{Days}] - \\ &\quad [(\text{DailyIdleEnergy}_{\text{ElecEE}} + \text{DailyPreheatEnergy}_{\text{ElecEE}} + \\ &\quad \text{DailyCookingEnergy}_{\text{ElecEE}}) * 3.412/1,000,000 * \text{Days}] \end{aligned}$$

$$\begin{aligned} \text{DailyIdleEnergy}_{\text{GasBase}} &= (14,000 * ((16 - 15/60) - 150 / 60)) \\ &= 185,500 \text{ btu} \end{aligned}$$

$$\text{DailyPreheatEnergy}_{\text{GasBase}} = 18,500$$

$$\begin{aligned} \text{DailyCookingEnergy}_{\text{GasBase}} &= (150 * 570 / 0.35) \\ &= 244,286 \text{ btu} \end{aligned}$$

$$\begin{aligned} \text{DailyIdleEnergy}_{\text{ElecEE}} &= (800 * ((16 - 15/60) - 150 / 70)) \\ &= 10,886 \text{ Wh} \end{aligned}$$

$$\begin{aligned} \text{DailyPreheatEnergy}_{\text{ElecEE}} &= 1.9 * 1,000 \\ &= 1,900 \text{ Wh} \end{aligned}$$

$$\begin{aligned} \text{DailyCookingEnergy}_{\text{ElecEE}} &= (150 * 167 / 0.83) \\ &= 30,181 \text{ Wh} \end{aligned}$$

$$\begin{aligned} \text{SiteEnergySavings (MMBTUs)} &= ((185,500 + 18,500 + 244,286) * 1/1,000,000 * 365.25) - \\ &\quad ((10,886 + 1,900 + 30,181) * 3.412/1,000,000 * 365.25) \\ &= 110 \text{ MMBtu} \end{aligned}$$

$$\begin{aligned} \text{If supported by an electric utility: } \Delta \text{kWh} &= \Delta \text{SiteEnergySavings} * 1,000,000 / 3,412 \\ &= 110 * 1,000,000/3,412 \\ &= 32,239 \text{ kWh} \end{aligned}$$

[Using Large Vat defaults = 103 MMBtu or 30,188 kWh]

### SUMMER COINCIDENT PEAK DEMAND SAVINGS

$$\Delta \text{kW} = ((\Delta \text{DailyIdleEnergy} + \Delta \text{DailyPreheatEnergy} + \Delta \text{DailyCookingEnergy}) / (1,000 * \text{HOURS}) * \text{CF}$$

$$\Delta \text{kW} = - ((\text{DailyIdleEnergy}_{\text{ElecEE}} + \text{DailyPreheatEnergy}_{\text{ElecEE}} + \text{DailyCookingEnergy}_{\text{ElecEE}}) / (1,000 * \text{HOURS}) * \text{CF}$$

Where:

CF = Summer Peak Coincidence Factor for measure is provided below for different locations:<sup>250</sup>

<sup>250</sup>Values taken from Minnesota Technical Reference Manual (Version 2.2, effective May 2, 2018), 'Electric Oven and Range' measure and are based upon "Project on Restaurant Energy Performance-End-Use Monitoring and Analysis", Appendixes I and II, Claar, et. al., May 1985.

Location	CF
Fast Food Limited Menu	0.32
Fast Food Expanded Menu	0.41
Pizza	0.46
Full Service Limited Menu	0.51
Full Service Expanded Menu	0.36
Cafeteria	0.39

Other variables as defined above.

**For example**, an ENERGY STAR standard-sized electric fryer in a cafeteria, using default values from the calculation above, would save:

$$\begin{aligned} \Delta kW &= (5,245 + 500 + 3,219) / (1000 * \text{HOURS}) * CF \\ &= 8964 / (1000 * 16) * 0.39 \\ &= 0.2185 \text{ kW} \end{aligned}$$

**FOSSIL FUEL SAVINGS**

Calculation provided together with Electric Energy Savings above.

**WATER IMPACT DESCRIPTIONS AND CALCULATION**

N/A

**DEEMED O&M COST ADJUSTMENT CALCULATION**

N/A

**COST EFFECTIVENESS SCREENING AND LOAD REDUCTION FORECASTING WHEN FUEL SWITCHING**

This measure can involve fuel switching from fossil fuel to electric.

For the purposes of forecasting load reductions due to fuel switch projects per Section 16-111.5B, changes in site energy use at the customer’s meter (using ΔkWh algorithm below), customer switching estimates, NTG, and any other adjustment factors deemed appropriate, should be used.

The inputs to cost effectiveness screening should reflect the actual impacts on the electric and fuel consumption at the customer meter and, for fuel switching measures, should therefore reflect the decrease in one fuel and increase in another, as opposed to the single savings value calculated in the “Electric and Fossil Fuel Energy Savings” section above. Therefore in addition to the calculation of savings claimed, the following values should be used to assess the cost effectiveness of the measure.

$$\begin{aligned} \Delta \text{Therms} &= [\text{Gas Cooking Consumption Replaced}] \\ &= [(\text{DailyIdleEnergy}_{\text{GasBase}} + \text{DailyPreheatEnergy}_{\text{GasBase}} + \text{DailyCookingEnergy}_{\text{GasBase}}) * 1/100,000 * \text{Days}] \\ \Delta \text{kWh} &= [\text{Electric Cooking Consumption Added}] \\ &= - [(\text{DailyIdleEnergy}_{\text{ElecEE}} + \text{DailyPreheatEnergy}_{\text{ElecEE}} + \text{DailyCookingEnergy}_{\text{ElecEE}}) * \text{Days} / 1,000] \end{aligned}$$

**MEASURE CODE: CI-FSE-ESFR-V05-240101**

**REVIEW DEADLINE: 1/1/2028**

## 4.2.8 ENERGY STAR Griddle

### DESCRIPTION

This measure applies to single or double-sided electric, natural gas fired, or dual fuel ENERGY STAR griddles installed in a commercial kitchen. For dual fuel griddles, savings should be divided between electric and gas as described in the Fossil Fuel Savings section of this measure.

This measure was developed to be applicable to the following program types: TOS. If applied to other program types, the measure savings should be verified.

### DEFINITION OF EFFICIENT EQUIPMENT

To qualify for this measure the installed equipment must be a single or double-sided natural gas, electric, or dual fuel ENERGY STAR griddle with a tested heavy load cooking energy efficiency of 70 percent (electric) 38 percent (gas) or greater and an idle energy rate of 2,650 Btu/hr per square foot of cooking surface or less, utilizing ASTM F1275. The griddle must have an Idle Energy Consumption Rate < 2,600 Btu/hr per square foot of cooking surface.

### DEFINITION OF BASELINE EQUIPMENT

The baseline equipment is an existing natural gas or electric griddle that’s not ENERGY STAR certified and is at end of use.

### DEEMED LIFETIME OF EFFICIENT EQUIPMENT

The expected measure life is assumed to be 12 years.<sup>251</sup>

### DEEMED MEASURE COST

The incremental capital cost for this measure is \$0 for and electric griddle and \$60 for a gas griddle.<sup>252</sup>

### LOADSHAPE

Loadshape C01 - Commercial Electric Cooking

### COINCIDENCE FACTOR

Summer Peak Coincidence Factor for measure is provided below for different building type:<sup>253</sup>

Location	CF
Fast Food Limited Menu	0.32
Fast Food Expanded Menu	0.41
Pizza	0.46
Full Service Limited Menu	0.51
Full Service Expanded Menu	0.36
Cafeteria	0.39

<sup>251</sup> Lifetime from ENERGY STAR Commercial Kitchen Equipment Calculator, Commercial Griddle Calculations, which cites reference as “FSTC research on available models, 2009”.

<sup>252</sup> Measure cost from ENERGY STAR Commercial Kitchen Equipment Calculator, which cites reference as “EPA research on available models using AutoQuotes, 2010”.

<sup>253</sup> Values taken from Minnesota Technical Reference Manual (Version 2.2, effective May 2, 2018), ‘Electric Oven and Range’ measure and are based upon “Project on Restaurant Energy Performance-End-Use Monitoring and Analysis”, Appendixes I and II, Claar, et. al., May 1985.

**Algorithm**

**CALCULATION OF SAVINGS <sup>254</sup>**

**ELECTRIC ENERGY AND FOSSIL FUEL SAVINGS**

**Non Fuel Switch Measures**

The algorithm below applies to ENERGY STAR compared to baseline electric griddles:

$$\Delta kWh = (\Delta IdleEnergy + \Delta PreheatEnergy + \Delta CookingEnergy) * Days / 1000$$

The algorithm below applies to ENERGY STAR compared to baseline gas griddles:

$$\Delta Therms = (\Delta IdleEnergy + \Delta PreheatEnergy + \Delta CookingEnergy) * Days / 100,000$$

**Fuel Switch/Electrification Measures:**

Fuel switch / electrification measures must produce positive total energy savings (i.e., reduction in Btus at the premises) in order to qualify. This is determined as follows:

$$\begin{aligned} \text{SiteEnergySavings (MMBTUs)} &= [\text{GasConsumptionReplaced}] - [\text{ElectricConsumptionAdded}] \\ &= [(\text{DailyIdleEnergy}_{\text{GasBase}} + \text{DailyPreheatEnergy}_{\text{GasBase}} + \text{DailyCookingEnergy}_{\text{GasBase}}) * 1/1,000,000 * \text{Days}] - \\ &\quad [(\text{DailyIdleEnergy}_{\text{ElecEE}} + \text{DailyPreheatEnergy}_{\text{ElecEE}} + \text{DailyCookingEnergy}_{\text{ElecEE}}) * 3.412/1,000,000 * \text{Days}] \end{aligned}$$

If SiteEnergySavings calculated above is positive, the measure is eligible.

The appropriate savings claim is dependent on which utilities are supporting the measure as provided in a table below:

Measure supported by:	Electric Utility claims (kWh):	Gas Utility claims (therms):
Electric utility only	SiteEnergySavings * 1,000,000/3,412	N/A
Electric and gas utility (Note utilities may make alternative agreements to how savings are allocated as long as total MMBtu savings remains the same).	%IncentiveElectric * SiteEnergySavings * 1,000,000/3,412	%IncentiveGas * SiteEnergySavings * 10
Gas utility only	N/A	SiteEnergySavings * 10

$$\begin{aligned} \Delta \text{DailyIdleEnergy} &= [(\text{Idle}_{\text{Base}} * \text{Width} * \text{Depth} * (\text{HOURSday} - (\text{LB}/(\text{PC}_{\text{Base}} * \text{Width} * \text{Depth}) - (\text{PreheatNumber}_{\text{Base}} * \text{PreheatTime}_{\text{Base}}/60)))] - [(\text{Idle}_{\text{ENERGYSTAR}} * \text{Width} * \text{Depth} * (\text{HOURSday} - (\text{LB}/(\text{PC}_{\text{ENERGYSTAR}} * \text{Width} * \text{Depth}) - (\text{PreheatNumber}_{\text{ENERGYSTAR}} * \text{PreheatTime}_{\text{ENERGYSTAR}}/60)))] \end{aligned}$$

<sup>254</sup> Algorithms and assumptions derived from ENERGY STAR Griddle Commercial Kitchen Equipment Savings Calculator.

$$\Delta \text{DailyPreheatEnergy} = (\text{PreHeatNumber}_{\text{Base}} * \text{PreheatTime}_{\text{Base}} / 60 * \text{PreheatRate}_{\text{Base}} * \text{Width} * \text{Depth}) - (\text{PreheatNumber}_{\text{ENERGYSTAR}} * \text{PreheatTime}_{\text{ENERGYSTAR}} / 60 * \text{PreheatRate}_{\text{ENERGYSTAR}} * \text{Width} * \text{Depth})$$

$$\Delta \text{DailyCookingEnergy} = (\text{LB} * \text{EFOOD} / \text{Eff}_{\text{Base}}) - (\text{LB} * \text{EFOOD} / \text{Eff}_{\text{ENERGYSTAR}})$$

$$\text{DailyIdle Energy}_{\text{GasBase}} = [(\text{Idle}_{\text{BaseGas}} * \text{Width} * \text{Depth} * (\text{HOURSday} - (\text{LB} / (\text{PC}_{\text{BaseGas}} * \text{Width} * \text{Depth}))) - (\text{PreheatNumber}_{\text{Base}} * \text{PreheatTime}_{\text{Base}} / 60)]$$

$$\text{DailyPreheat Energy}_{\text{GasBase}} = (\text{PreheatNumber}_{\text{Base}} * \text{PreheatTime}_{\text{Base}} / 60 * \text{PreheatRate}_{\text{BaseGas}} * \text{Width} * \text{Depth})$$

$$\text{DailyCooking Energy}_{\text{GasBase}} = (\text{LB} * \text{EFOOD} / \text{Eff}_{\text{BaseGas}})$$

$$\text{DailyIdle Energy}_{\text{ElecEE}} = [(\text{Idle}_{\text{ENERGYSTARElec}} * \text{Width} * \text{Depth} * (\text{HOURSday} - (\text{LB} / (\text{PC}_{\text{ENERGYSTARElec}} * \text{Width} * \text{Depth}))) - (\text{PreheatNumber}_{\text{ENERGYSTAR}} * \text{PreheatTime}_{\text{ENERGYSTAR}} / 60)]$$

$$\text{DailyPreheat Energy}_{\text{ElecEE}} = (\text{PreheatNumber}_{\text{ENERGYSTAR}} * \text{PreheatTime}_{\text{ENERGYSTAR}} / 60 * \text{PreheatRate}_{\text{ENERGYSTAR}} * \text{Width} * \text{Depth})$$

$$\text{DailyCooking Energy}_{\text{ElecEE}} = (\text{LB} * \text{EFOOD} / \text{Eff}_{\text{ENERGYSTARElec}})$$

Where:

- $\text{Idle}_{\text{Base}}$  = Idle energy rate of baseline griddle  
 = Actual or if unknown, use 400 W/h/sq ft for electric and 3,500 Btu/h/sq ft for gas
- $\text{Idle}_{\text{ENERGYSTAR}}$  = Idle energy rate of ENERGY STAR griddle  
 = Actual or if unknown, use 320 W/h/sq ft for electric and 2,650 Btu/h/sq ft for gas
- LB = Food cooked per day  
 = Actual or if unknown, use 100 pounds
- Width = Griddle Width  
 = Actual or if unknown, use 3 feet
- Depth = Griddle Depth  
 = Actual or if unknown, use 2 feet
- $\text{PC}_{\text{Base}}$  = Production Capacity base  
 = Actual or if unknown, use 35/6 = 5.83 pounds/hr/sq ft for electric and 25/6 = 4.17 pounds/hr/sq ft for gas
- $\text{PC}_{\text{ENERGYSTAR}}$  = Production Capacity ENERGY STAR  
 = Actual or if unknown, use 40/6 = 6.67 pounds/hr/sq ft for electric and 45/6 = 7.5 pounds/hr/sq ft for gas
- $\text{PreheatNumber}_{\text{Base}}$  = Number of preheats per day base  
 = Actual or if unknown, use 1
- $\text{PreheatNumber}_{\text{ENERGYSTAR}}$  = Number of preheats per day ENERGY STAR  
 = Actual or if unknown, use 1
- $\text{PreheatTime}_{\text{Base}}$  = preheat length base (mins)

	= Actual or if unknown, use 15 minutes
PreheatTime <sub>ENERGYSTAR</sub>	= preheat length ENERGY STAR (mins)
	= Actual or if unknown, use 15 minutes
PreheatRate <sub>Base</sub>	= preheat energy rate baseline
	= Actual or if unknown, use 16000/6 = 2,667 W/sq ft for electric and 84,000/6 = 14,000 btu/h/sq ft
PreheatRate <sub>ENERGYSTAR</sub>	= preheat energy rate ENERGY STAR
	= Actual or if unknown, use 8000/6 = 1,333 W/sq ft for electric and 60,000/6 = 10,000 btu/h/sq ft for gas
E <sub>FOOD</sub>	= ASTM energy to food
	= 139 w/pound for electric and 475 btu/pound for gas
Eff <sub>Base</sub>	= Cooking Efficiency Baseline
	= Actual or if unknown, use 65% for electric and 32% for gas
Eff <sub>ENERGYSTAR</sub>	= Cooking Efficiency ENERGY STAR
	= Actual or if unknown, use 70% for electric and 38% for gas
HOURS <sub>day</sub>	= Average Daily Operation
	= Actual or if unknown, use 12 hours
Days	= Annual days of operation
	= Actual or if unknown, use 365.25 days a year

For dual fuel griddles, assume that half of the therms savings calculated according to the algorithm above are gas savings and half are electric savings.<sup>255</sup> Electric savings for dual griddles should be calculated as  $\Delta kWh = (\Delta Therms * 0.50) * 29.3$ .

---

<sup>255</sup> Dual fuel griddles are usually electric top plates and gas bottom plates, often used by fast food restaurants. As per DOE workpaper "Energy Savings Potential and RD&D Opportunities for Commercial Building Appliances (2015 Update)" these models have a "second heating plate that is lowered on top of the food and used to simultaneously cook both sides." It therefore is reasonable to assume half savings are attributed to gas v electric.



**For example**, an ENERGY STAR electric griddle with a tested heavy load cooking energy efficiency of 70 percent and an idle energy rate of 320 W per square foot of cooking surface or less, compared with baseline electric griddle would save:

$$\begin{aligned} \Delta\text{DailyIdleEnergy} &= [400 * 3 * 2 * (12 - (100/(35/6 * 3 * 2)) - (1 * 15/60)) - [320 * 3 * 2 * (12 - (100/(40/6 * 3 * 2)) - (1 * 15/60))] \\ &= 3583 \text{ W} \\ \Delta\text{DailyPreheatEnergy} &= (1 * 15 / 60 * 16000/6 * 3 * 2) - (1 * 15/60 * 8000/6 * 3 * 2) \\ &= 2000\text{W} \\ \Delta\text{DailyCookingEnergy} &= (100 * 139 / 0.65) - (100 * 139 / 0.70) \\ &= 1527 \text{ W} \\ \Delta\text{kWh} &= (2000+1527+3583) * 365.25 /1000 \\ &= 2597 \text{ kWh} \end{aligned}$$

**For example**, an ENERGY STAR gas griddle with a tested heavy load cooking energy efficiency of 38 percent and an idle energy rate of 2,650 Btu/h per square foot of cooking surface, compared with baseline gas griddle would save:

$$\begin{aligned} \Delta\text{DailyIdleEnergy} &= [3500 * 3 * 2 * (12 - 100/(25/6 * 3 * 2)) - (1 * 15/60)] - [(2650 * 3 * 2 * (12 - (100/(45/6 * 3 * 2)) - (1 * 15/60)))] \\ &= 11,258 \text{ Btu} \\ \Delta\text{DailyPreheatEnergy} &= (1 * 15 / 60 * 14,000 * 3 * 2) - (1 * 15/60 * 10000 * 3 * 2) \\ &= 6,000 \text{ btu} \\ \Delta\text{DailyCookingEnergy} &= (100 * 475/ 0.32) - (100 * 475/ 0.38) \\ &=23,438 \text{ btu} \\ \Delta\text{Therms} &= (11258 + 6000 + 23438) * 365.25 /100000 \\ &=149 \text{ therms} \end{aligned}$$

An ENERGY STAR electric griddle compared to baseline gas griddle assuming default values from above would save.

$$\begin{aligned} \text{SiteEnergySavings (MMBTUs)} &= [\text{GasConsumptionReplaced}] - [\text{ElectricConsumptionAdded}] \\ &= [(\text{DailyIdleEnergy}_{\text{GasBase}} + \text{DailyPreheatEnergy}_{\text{GasBase}} + \text{DailyCookingEnergy}_{\text{GasBase}}) * 1/1,000,000 * \text{Days}] - \\ &\quad [(\text{DailyIdleEnergy}_{\text{ElecEE}} + \text{DailyPreheatEnergy}_{\text{ElecEE}} + \text{DailyCookingEnergy}_{\text{ElecEE}}) * 3.412/1,000,000 * \text{Days}] \end{aligned}$$

$$\begin{aligned} \text{DailyIdleEnergy}_{\text{GasBase}} &= [3500 * 3 * 2 * (12 - 100/(25/6 * 3 * 2)) - (1 * 15/60)] \\ &= 168,000 \text{ btu} \end{aligned}$$

$$\begin{aligned} \text{DailyPreheatEnergy}_{\text{GasBase}} &= (1 * 15 / 60 * 14,000 * 3 * 2) \\ &= 21,000 \text{ btu} \end{aligned}$$

$$\begin{aligned} \text{DailyCookingEnergy}_{\text{GasBase}} &= (100 * 475 / 0.32) \\ &= 148,438 \text{ btu} \end{aligned}$$

$$\begin{aligned} \text{DailyIdleEnergy}_{\text{ElecEE}} &= [320 * 3 * 2 * (12 - (100/(40/6 * 3 * 2)) - (1 * 15/60)] \\ &= 17,760 \text{ Wh} \end{aligned}$$

$$\begin{aligned} \text{DailyPreheatEnergy}_{\text{ElecEE}} &= (1 * 15/60 * 8000/6 * 3 * 2) \\ &= 2,000 \text{ Wh} \end{aligned}$$

$$\begin{aligned} \text{DailyCookingEnergy}_{\text{ElecEE}} &= (100 * 139 / 0.70) \\ &= 19,857 \text{ Wh} \end{aligned}$$

$$\begin{aligned} \text{SiteEnergySavings (MMBTUs)} &= ((168,000 + 21,000 + 148,438) * 1/1,000,000 * 365.25) - \\ &\quad ((17,760 + 2,000 + 19,857) * 3.412/1,000,000 * 365.25) \\ &= 73.9 \text{ MMBtu} \end{aligned}$$

$$\begin{aligned} \text{If supported by an electric utility: } \Delta\text{kWh} &= \Delta\text{SiteEnergySavings} * 1,000,000 / 3,412 \\ &= 73.9 * 1,000,000/3,412 \\ &= 21,659 \text{ kWh} \end{aligned}$$

### SUMMER COINCIDENT PEAK DEMAND SAVINGS

Non-fuel switch measures:

$$\text{kW} = (\Delta\text{IdleEnergy} + \Delta\text{PreheatEnergy} + \Delta\text{CookingEnergy}) / (1,000 * \text{HoursDay}) * \text{CF}$$

Fuel switch measures:

$$\text{kW} = - ((\text{DailyIdleEnergy}_{\text{ElecEE}} + \text{DailyPreheatEnergy}_{\text{ElecEE}} + \text{DailyCookingEnergy}_{\text{ElecEE}}) / (1,000 * \text{HoursDay}) * \text{CF}$$

**For example**, an ENERGY STAR griddle in a cafeteria with a tested heavy load cooking energy efficiency of 70 percent or greater and an idle energy rate of 320 W per square foot of cooking surface or less would save

$$= (2000+1527+3583)/(1000 * 12) * 0.39$$

$$= 0.231 \text{ kW}$$

**FOSSIL FUEL SAVINGS**

Calculation provided together with Electric Energy Savings above.

**WATER IMPACT DESCRIPTIONS AND CALCULATION**

N/A

**DEEMED O&M COST ADJUSTMENT CALCULATION**

N/A

**COST EFFECTIVENESS SCREENING AND LOAD REDUCTION FORECASTING WHEN FUEL SWITCHING**

This measure can involve fuel switching from fossil fuel to electric.

For the purposes of forecasting load reductions due to fuel switch projects per Section 16-111.5B, changes in site energy use at the customer’s meter (using ΔkWh algorithm below), customer switching estimates, NTG, and any other adjustment factors deemed appropriate, should be used.

The inputs to cost effectiveness screening should reflect the actual impacts on the electric and fuel consumption at the customer meter and, for fuel switching measures, should therefore reflect the decrease in one fuel and increase in another, as opposed to the single savings value calculated in the “Electric and Fossil Fuel Energy Savings” section above. Therefore in addition to the calculation of savings claimed, the following values should be used to assess the cost effectiveness of the measure.

$$\begin{aligned} \Delta\text{Therms} &= [\text{Gas Cooking Consumption Replaced}] \\ &= [(\text{DailyIdleEnergy}_{\text{GasBase}} + \text{DailyPreheatEnergy}_{\text{GasBase}} + \text{DailyCookingEnergy}_{\text{GasBase}}) * \\ &\quad 1/100,000 * \text{Days}] \\ \Delta\text{kWh} &= [\text{Electric Cooking Consumption Added}] \\ &= - [(\text{DailyIdleEnergy}_{\text{ElecEE}} + \text{DailyPreheatEnergy}_{\text{ElecEE}} + \text{DailyCookingEnergy}_{\text{ElecEE}}) * \text{Days} / \\ &\quad 1,000] \end{aligned}$$

**MEASURE CODE: CI-FSE-ESGR-V06-240101**

**REVIEW DEADLINE: 1/1/2028**

## 4.2.9 ENERGY STAR Hot Food Holding Cabinets

### DESCRIPTION

This measure applies to electric ENERGY STAR hot food holding cabinets (HFHC) installed in a commercial kitchen.

This measure was developed to be applicable to the following program types: TOS. If applied to other program types, the measure savings should be verified.

### DEFINITION OF EFFICIENT EQUIPMENT

To qualify for this measure the installed equipment must be an ENERGY STAR certified HFHC.

### DEFINITION OF BASELINE EQUIPMENT

The baseline equipment is an electric HFHC that’s not ENERGY STAR certified and at end of life.

### DEEMED LIFETIME OF EFFICIENT EQUIPMENT

The expected measure life is assumed to be 12 years.<sup>256</sup>

### DEEMED MEASURE COST

The incremental capital cost for this measure is \$1,000.<sup>257</sup>

### LOADSHAPE

Loadshape C01 - Commercial Electric Cooking

### COINCIDENCE FACTOR

Summer Peak Coincidence Factor for measure is provided below for different building type:<sup>258</sup>

Location	CF
Fast Food Limited Menu	0.32
Fast Food Expanded Menu	0.41
Pizza	0.46
Full Service Limited Menu	0.51
Full Service Expanded Menu	0.36
Cafeteria	0.39

<sup>256</sup> Lifetime from ENERGY STAR Commercial Kitchen Equipment Calculator, Hot Food Holding Cabinet Calculations, which cites reference as “FSTC research on available models, 2009”.

<sup>257</sup> Measure cost from ENERGY STAR Commercial Kitchen Equipment Calculator, published 2021, which cites reference as “EPA research using AutoQuotes, 2020”.

<sup>258</sup> Values taken from Minnesota Technical Reference Manual (Version 2.2, effective May 2, 2018), ‘Electric Oven and Range’ measure and are based upon “Project on Restaurant Energy Performance-End-Use Monitoring and Analysis”, Appendixes I and II, Claar, et. al., May 1985.

**Algorithm**

**CALCULATION OF SAVINGS**

**ELECTRIC ENERGY SAVINGS**

Custom calculation below, otherwise use deemed values of 545 kWh.<sup>259</sup>

$$\Delta kWh = (\text{IdleEnergyRateBase} - \text{IdleEnergyRateES}) * \text{HOURSday} * \text{Days}/1000$$

Where:

- IdleEnergyRateBase = Custom, otherwise  
= 30 \* V
- V = Volume of HFHC (cubic feet)  
= Custom, otherwise assume 15 cu ft
- HOURSday = Average Daily Operation  
= custom or if unknown, use 9 hours
- Days = Annual days of operation  
= custom or if unknown, use 365 days a year
- IdleEnergyRateES = Custom, otherwise assume maximum ENERGY STAR Idle Energy Rate presented below. If volume is unknown assume 15 cu ft, resulting in 284W:

Cabinet Volume (cu ft)	Power (W)
V < 13	21.5 * V
13 ≤ V < 28	2*V+254
28 ≤ V	3.8*V+203.5

**For example**, if a full size HFHC, with a volume of 15 cubic ft, is installed the measure would save:

$$\begin{aligned} \Delta kWh &= ((15*30)-(2*V+254))*9*365/1,000 \\ &= (450 - 284)*9*365 /1,000 \\ &= 545 kWh \end{aligned}$$

**SUMMER COINCIDENT PEAK DEMAND SAVINGS**

$$\Delta kW = \Delta kWh/\text{Hours} * CF$$

Where:

$$\text{Hours} = \text{Hoursday} * \text{Days}$$

**For example**, if a full size HFHC, with a volume of 15 cubic feet, is installed in a cafeteria the measure would save:

$$\begin{aligned} &= 545 kWh / (9*365)* .39 \\ &= 0.0647 kW \end{aligned}$$

<sup>259</sup> Algorithms and assumptions derived from ENERGY STAR Commercial Kitchen Equipment Savings Calculator, published 2021.

**FOSSIL FUEL SAVINGS**

N/A

**WATER IMPACT DESCRIPTIONS AND CALCULATION**

N/A

**DEEMED O&M COST ADJUSTMENT CALCULATION**

N/A

**MEASURE CODE: CI-FSE-ESHH-V04-230101**

**REVIEW DEADLINE: 1/1/2026**

#### 4.2.10 Ice Maker

##### DESCRIPTION

This measure relates to the installation of a new ENERGY STAR qualified commercial ice machine. The ENERGY STAR label applied to air-cooled, cube-type machines including ice-making head, self-contained, and remote-condensing units. This measure could relate to the replacing of an existing unit at the end of its useful life, or the installation of a new system in a new or existing building.

This measure was developed to be applicable to the following program types: TOS and NC. If applied to other program types, the measure savings should be verified.

##### DEFINITION OF EFFICIENT EQUIPMENT

In order for this characterization to apply, the efficient equipment is assumed to be a new commercial ice machine meeting the minimum ENERGY STAR efficiency level standards.

**ENERGY STAR Requirements (Version 3.0, Effective January 28, 2018)**

ENERGY STAR Requirements for Air-Cooled Batch-Type Ice Makers			
Equipment Type	Applicable Ice Harvest Rate Range (lbs of ice/24 hrs)	ENERGY STAR Energy Consumption Rate (kWh/100 lbs ice)	Potable Water Use (gal/100 lbs ice)
IMH	$H < 300$	$\leq 9.20 - 0.01134H$	$\leq 20.0$
	$300 \leq H < 800$	$\leq 6.49 - 0.0023H$	
	$800 \leq H < 1500$	$\leq 5.11 - 0.00058H$	
	$1500 \leq H \leq 4000$	$\leq 4.24$	
RCU	$H < 988$	$\leq 7.17 - 0.00308H$	$\leq 20.0$
	$988 \leq H \leq 4000$	$\leq 4.13$	
SCU	$H < 110$	$\leq 12.57 - 0.0399H$	$\leq 25.0$
	$110 \leq H < 200$	$\leq 10.56 - 0.0215H$	
	$200 \leq H \leq 4000$	$\leq 6.25$	
ENERGY STAR Requirements for Air-Cooled Continuous-Type Ice Makers			
Equipment Type	Applicable Ice Harvest Rate Range (lbs of ice/24 hrs)	ENERGY STAR Energy Consumption Rate (kWh/100 lbs ice)	Potable Water Use (gal/100 lbs ice)
IMH	$H < 310$	$\leq 7.90 - 0.005409H$	$\leq 15.0$
	$310 \leq H < 820$	$\leq 7.08 - 0.002752H$	
	$820 \leq H \leq 4000$	$\leq 4.82$	
RCU	$H < 800$	$\leq 7.76 - 0.00464H$	$\leq 15.0$
	$800 \leq H \leq 4000$	$\leq 4.05$	
SCU	$H < 200$	$\leq 12.37 - 0.0261H$	$\leq 15.0$
	$200 \leq H < 700$	$\leq 8.24 - 0.005429H$	
	$700 \leq H \leq 4000$	$\leq 4.44$	

##### DEFINITION OF BASELINE EQUIPMENT

In order for this characterization to apply, the baseline equipment is assumed to be a commercial ice machine meeting federal equipment standards established January 28, 2018.

### DEEMED LIFETIME OF EFFICIENT EQUIPMENT

The expected measure life is assumed to be 9 years.<sup>260</sup>

### DEEMED MEASURE COST

When available, the actual cost of the measure installation and equipment shall be used. The incremental capital cost for this measure is \$0 for Batch-Type and Continuous-Type<sup>261</sup>.

### LOADSHAPE

Loadshape C23 - Commercial Refrigeration

### COINCIDENCE FACTOR

The Summer Peak Coincidence Factor is assumed to equal 0.937.

---

### Algorithm

---

### CALCULATION OF SAVINGS

#### ELECTRIC ENERGY SAVINGS

$$\Delta\text{kWh} = [(\text{kWh}_{\text{base}} - \text{kWh}_{\text{ee}}) / 100] * (\text{DC} * \text{H}) * 365.25$$

Where:

- $\text{kWh}_{\text{base}}$  = maximum kWh consumption per 100 pounds of ice for the baseline equipment
  - = calculated as shown in the table below using the actual Harvest Rate (H) of the efficient equipment<sup>262</sup>.
- $\text{kWh}_{\text{ee}}$  = maximum kWh consumption per 100 pounds of ice for the efficient equipment
  - = actual if known. If unknown calculate as shown in the table below using the actual Harvest Rate (H) of the efficient equipment.

---

<sup>260</sup> Based on DOE Technical Support Document, 2014 as recommended in Navigant 'ComEd Effective Useful Life Research Report', May 2018.

<sup>261</sup> Incremental costs from ENERGY STAR Commercial Kitchen Equipment Savings Calculator. Calculator cites EPA research using AutoQuotes, 2016.

<sup>262</sup> Use the appropriate equipment type baseline and ice harvest rate range when calculating the savings for a CEE Tier Advanced ice maker.



Energy Consumption of Air-Cooled Batch-Type Ice Makers			
Ice Maker Type	Applicable Ice Harvest Rate Range (lbs of ice/24 hrs)	kWh <sub>Base</sub>	kWh <sub>ESTAR</sub>
IMH	H < 300	10-0.01233H	≤ 9.20 - 0.01134H
	300 ≤ H < 800	7.05-0.0025H	≤ 6.49 - 0.0023H
	800 ≤ H < 1500	5.55-0.00063H	≤ 5.11 - 0.00058H
	1500 ≤ H ≤ 4000	4.61	≤ 4.24
RCU	H < 988	7.97-0.00342H	≤ 7.17 – 0.00308H
	988 ≤ H ≤ 4000	4.59	≤ 4.13
SCU	H < 110	14.79-0.0469H	≤ 12.57 - 0.0399H
	110 ≤ H < 200	12.42-0.02533H	≤ 10.56 - 0.0215H
	200 ≤ H ≤ 4000	7.35	≤ 6.25
Energy Consumption of Air-Cooled Continuous-Type Ice Makers			
Equipment Type	Applicable Ice Harvest Rate Range (lbs of ice/24 hrs)	kWh <sub>Base</sub>	kWh <sub>ESTAR</sub>
IMH	H < 310	9.19-0.00629H	≤ 7.90 – 0.005409H
	310 ≤ H < 820	8.23-0.0032H	≤ 7.08 – 0.002752H
	820 ≤ H ≤ 4000	5.61	≤ 4.82
RCU	H < 800	9.7-0.0058H	≤ 7.76 – 0.00464H
	800 ≤ H ≤ 4000	5.06	≤ 4.05
SCU	H < 200	14.22-0.03H	≤ 12.37 – 0.0261H
	200 ≤ H < 700	9.47-0.00624H	≤ 8.24 – 0.005429H
	700 ≤ H ≤ 4000	5.1	≤ 4.44

100 = conversion factor to convert kWh<sub>base</sub> and kWh<sub>est</sub> into maximum kWh consumption per pound of ice.

DC = Duty Cycle of the ice machine

$$= 0.57^{263}$$

H = Harvest Rate (pounds of ice made per day)

= Actual installed

365.35 = days per year

**For example**, a batch ice machine with an ice making head producing 450 pounds of ice would save

$$\begin{aligned} \Delta \text{kWh} &= [(5.9 - 5.5) / 100] * (0.57 * 450) * 365.25 \\ &= 440 \text{ kWh} \end{aligned}$$

<sup>263</sup>Duty cycle varies considerably from one installation to the next. TRM assumptions from Vermont, Wisconsin, and New York vary from 40 to 57%, whereas the ENERGY STAR Commercial Ice Machine Savings Calculator assumes a value of 75%. A field study of eight ice machines in California indicated an average duty cycle of 57% (“A Field Study to Characterize Water and Energy Use of Commercial Ice-Cube Machines and Quantify Saving Potential”, Food Service Technology Center, December 2007). Furthermore, a report prepared by ACEEE assumed a value of 40% (Nadel, S., Packaged Commercial Refrigeration Equipment: A Briefing Report for Program Planners and Implementers, ACEEE, December 2002). The value of 57% was utilized since it appears to represent a high quality data source.

**SUMMER COINCIDENT PEAK DEMAND SAVINGS**

$$\Delta kW = \Delta kWh / (\text{HOURS} * DC) * CF$$

Where:

HOURS = annual operating hours

$$= 8766^{264}$$

CF = 0.937

**For example**, an ice machine with an ice making head producing 450 pounds of ice would save

$$\Delta kW = 440 / (8766 * 0.57) * .937$$

$$= 0.083 \text{ kW}$$

**FOSSIL FUEL SAVINGS**

N/A

**WATER IMPACT DESCRIPTIONS AND CALCULATION**

While the ENERGY STAR labeling criteria require that certified commercial ice machines meet certain “maximum potable water use per 100 pounds of ice made” requirements, such requirements are intended to prevent equipment manufacturers from gaining energy efficiency at the cost of water consumptions. A review of the AHRI Certification Directory<sup>265</sup> indicates that approximately 81% of air-cooled, cube-type machines meet the ENERGY STAR potable water use requirement. Therefore, there are no assumed water impacts for this measure.

**DEEMED O&M COST ADJUSTMENT CALCULATION**

N/A

**MEASURE CODE: CI-FSE-ESIM-V07-240101**

**REVIEW DEADLINE: 1/1/2027**

---

<sup>264</sup>Unit is assumed to be connected to power 24 hours per day, 365.25 days per year.

<sup>265</sup>AHRI Certification Directory, Automatic Commercial Ice Makers, Accessed on 7/7/10.

## 4.2.11 High Efficiency Pre-Rinse Spray Valve

### DESCRIPTION

Pre-rinse spray valves use a spray of water to remove food waste from dishes prior to cleaning in a dishwasher. More efficient spray valves use less water thereby reducing water consumption, water heating cost, and waste water (sewer) charges. Pre-rinse spray valves include a nozzle, squeeze lever, and dish guard bumper. Pre-rinse spray valves are manually operated, and the frequency of use depends on the volume of dirty dishes washed at a facility. The primary impacts of this measure are water savings. Reduced hot water consumption saves either natural gas or electricity, depending on the type of energy the hot water heater uses.

This measure was developed to be applicable to the following program types: TOS, EREP, KITS and DI. If applied to other program types, the measure savings should be verified.

### DEFINITION OF EFFICIENT EQUIPMENT

To qualify for this measure, the new or replacement pre-rinse spray nozzle must have a maximum flow rate that meets program requirements.

### DEFINITION OF BASELINE EQUIPMENT

The baseline equipment flow rate depends on program type. For TOS, the baseline equipment is a new pre-rinse spray valve with a maximum flow rate of 1.23 gpm or less.<sup>266</sup> For EREP and DI, the baseline equipment is an existing pre-rinse spray valve with an assumed flow rate of 2.14 gpm or less.<sup>267</sup>

### DEEMED LIFETIME OF EFFICIENT EQUIPMENT

The expected measure life is assumed to be 5 years.<sup>268</sup>

### DEEMED MEASURE COST

When available, the actual cost of the measure (including labor where applicable) should be used. If unknown, the incremental cost of this measure for TOS programs is assumed to be \$0.<sup>269</sup> For EREP, KITS and DI programs, the total installed cost is assumed to be \$54.<sup>270</sup>

### LOADSHAPE

Loadshape C01 - Commercial Electric Cooking

### COINCIDENCE FACTOR

N/A

<sup>266</sup> Baseline for TOS programs is calculated using the maximum flow rate for each product class in 10 CFR 431.266, Energy Efficiency Program for Certain Commercial and Industrial Equipment weighted by estimated 2018 shipments for each product class from Table 3.6.1: U.S. DOE, "Technical Support Document: Energy Efficiency Program for Consumer Products and Commercial and Industrial Equipment: Commercial Prerinse Spray Valves," December 2015.

<sup>267</sup> Average flow rate of spray valve replaced through direct install programs from DNV-GL, "Impact Evaluation of National Grid Rhode Island C&I Prescriptive Gas Pre-Rinse Spray Valve Measure – Final Report," September 30, 2014, page 6-6.

<sup>268</sup> Measure life from U.S. DOE, "Technical Support Document: Energy Efficiency Program for Consumer Products and Commercial and Industrial Equipment: Commercial Prerinse Spray Valves," December 2015, page 8-13."

<sup>269</sup> Incremental measure cost based on U.S. DOE, "Technical Support Document: Energy Efficiency Program for Consumer Products and Commercial and Industrial Equipment: Commercial Prerinse Spray Valves," December 2015, page 8-1.

<sup>270</sup> Total installed cost is the manufacturer selling price (\$35.40) from Table 8.2.1 multiplied by the retailer markup (1.52) from Table 8.2.2: U.S. DOE, "Technical Support Document: Energy Efficiency Program for Consumer Products and Commercial and Industrial Equipment: Commercial Prerinse Spray Valves," December 2015. It is assumed that programs typically install spray valves only when other kitchen equipment is also being installed, and therefore, there are no additional labor costs associated with spray valve installations.

**Algorithm**

**CALCULATION OF ENERGY SAVINGS**

**ELECTRIC ENERGY SAVINGS (NOTE WATER SAVINGS MUST FIRST BE CALCULATED)**

$$\Delta kWh = \Delta Water \text{ (gallons)} * 8.33 * 1 * (T_{out} - T_{in}) * (1/EFF\_Elec) / 3,412 * FLAG$$

Where:

- $\Delta Water$  (gallons) = amount of water saved as calculated below
- 8.33 = specific mass in pounds of one gallon of water (lbm/gal)
- 1 = Specific heat of water: 1 Btu/lbm/°F
- $T_{out}$  = Water Heater Outlet Water Temperature  
= custom, otherwise assume  $T_{in} + 70^\circ F$  temperature rise from  $T_{in}$ <sup>271</sup>
- $T_{in}$  = Inlet Water Temperature  
= custom, otherwise assume  $50.7^\circ F$ <sup>272</sup>
- $EFF\_Elec$  = Efficiency of electric water heater supplying hot water to pre-rinse spray valve  
= custom, otherwise assume 98%<sup>273</sup>
- Flag = 1 if electric or 0 if gas

**Time of Sale: For example**, a new spray nozzle with 0.98 gal/min flow replacing a nozzle with 1.23 gal/min flow at a large institutional establishments with a cafeteria with 70 degree temperature rise of water used by the pre-rinse spray valve that is heated by electric hot water saves annually :

$$\begin{aligned} \Delta kWh &= 14,040 * 8.33 * 1 * ((70+50.7) - 50.7) * (1/.98) / 3,412 * 1 \\ &= 2,448 kWh \end{aligned}$$

**Retrofit: For example**, a new spray nozzle with 0.98 gal/min flow replacing a nozzle with 2.14 gal/min flow at a large institutional establishments with a cafeteria with 70 degree temperature rise of water used by the pre-rinse spray valve that is heated by electric hot water equals:

$$\begin{aligned} \Delta kWh &= 65,146 * 8.33 * 1 * ((70+ 50.7) - 50.7) * (1/.98) / 3,412 * 1 \\ &= 11,360 kWh \end{aligned}$$

Secondary kWh Savings for Water Supply and Wastewater Treatment

The following savings should be included in the total savings for this measure, but should not be included in TRC tests to avoid double counting the economic benefit of water savings.

$$\Delta kWh_{water} = \Delta Water \text{ (gallons)} / 1,000,000 * E_{water \text{ total}}$$

Where:

- $E_{water \text{ total}}$  = IL Total Water Energy Factor (kWh/Million Gallons)

<sup>271</sup>If unknown, assume a 70 degree temperature rise from  $T_{in}$  per Food Service Technology Center calculator assumptions to account for variations in mixing and water heater efficiencies.

<sup>272</sup> Table 4 in Chen, et. al., "Calculating Average Hot Water Mixes of Residential Plumbing Fixtures", June 2020, reports a value of  $50.7^\circ F$  for inlet water temperature for U.S. Census Division 3.

<sup>273</sup> Electric water heaters have recovery efficiency of 98%, as sourced from available products on the AHRI Certification Directory.

$$=5,010^{274}$$

**Time of Sale: For example,** a new spray nozzle with 0.98 gal/min flow replacing a nozzle with 1.23 gal/min flow at a large institutional establishment with a cafeteria equals

$$\begin{aligned} \Delta\text{Water (gallons)} &= (1.23 - 0.98) * 60 * 3 * 312 \\ &= 14,040 \text{ gal/yr} \\ \Delta\text{kWh}_{\text{water}} &= 14,040/1,000,000 * 5,010 \\ &= 70 \text{ kWh} \end{aligned}$$

#### SUMMER COINCIDENT PEAK DEMAND SAVINGS

N/A

#### FOSSIL FUEL SAVINGS

$$\Delta\text{Therms} = \Delta\text{Water (gallons)} * 8.33 * 1 * (\text{Tout} - \text{Tin}) * (1/\text{EFF}_{\text{Gas}}) / 100,000 * (1 - \text{FLAG})$$

Where (new variables only):

$$\begin{aligned} \text{EFF}_{\text{Gas}} &= \text{Efficiency of gas water heater supplying hot water to pre-rinse spray valve} \\ &= \text{custom, otherwise assume } 80\%^{275} \end{aligned}$$

**Time of Sale: For example,** a new spray nozzle with 0.98 gal/min flow replacing a nozzle with 1.23 gal/min flow at a large institutional establishments with a cafeteria with 70 degree temperature of water used by the pre-rinse spray valve that is heated by fossil fuel hot water saves annually:

$$\begin{aligned} \Delta\text{Therms} &= 14,040 * 8.33 * 1 * ((70+50.7) - 50.7) * (1/0.80)/100,000 * (1-0) \\ &= 102 \text{ Therms} \end{aligned}$$

**Retrofit: For example,** a new spray nozzle with 0.98 gal/min flow replacing a nozzle with 2.14 gal/min flow at a busy large institutional establishments with a cafeteria with 70 degree temperature rise of water used by the pre-rinse spray valve that is heated by fossil fuel hot water saves annually:

$$\begin{aligned} \Delta\text{Therms} &= 65,146 * 8.33 * 1 * ((70+50.7) - 50.7) * (1/0.80)/100,000 * (1-0) \\ &= 475 \text{ Therms} \end{aligned}$$

#### WATER IMPACT CALCULATION<sup>276</sup>

$$\Delta\text{Water (gallons)} = (\text{FLO}_{\text{base}} - \text{FLO}_{\text{eff}}) * 60 * \text{HOURS}_{\text{day}} * \text{DAYS}_{\text{year}} * \text{ISR}$$

Where:

$$\text{FLO}_{\text{base}} = \text{Base case flow in gallons per minute, or custom (Gal/min)}$$

<sup>274</sup> This factor include 2571 kWh/MG for water supply based on Illinois energy intensity data from a 2012 ISAWWA study and 2439 kWh/MG for wastewater treatment based on national energy intensity use estimates. For more information please review Elevate Energy's 'IL TRM: Energy per Gallon Factor, May 2018 paper'.

<sup>275</sup> IECC 2015, Table C404.2, Minimum Performance of Water-Heating Equipment

<sup>276</sup> In order to calculate energy savings, water savings must first be calculated

Time of Sale	Direct Install
1.23 gal/min <sup>277</sup>	2.14 gal/min <sup>278</sup>

FLO<sub>eff</sub> = Efficient case flow in gallons per minute or custom (Gal/min)  
 = 0.98 gal/min<sup>279</sup>

60 = Minutes per hour

HOURS<sub>day</sub> = Hours per day that the pre-rinse spray valve is used at the site, custom, otherwise:<sup>280</sup>

Application	Hours/day
Small, quick- service restaurants	1
Medium-sized casual dining restaurants	1.5
Large institutional establishments with cafeteria	3

DAYS<sub>year</sub> = Days per year pre-rinse spray valve is used at the site, custom, otherwise 312 days/yr based on assumed 6 days/wk x 52 wk/yr = 312 day/yr.

ISR = in-service-rate, the percentage of units actually installed. For kits programs, if survey data is unavailable, use 0.466<sup>281</sup>. For all other programs use 1.0.

**Time of Sale:** For example, a new spray nozzle with 0.98 gal/min flow replacing a nozzle with 1.23 gal/min flow at a large institutional establishment with a cafeteria equals

$$= (1.23 - 0.98) * 60 * 3 * 312$$

$$= 14,040 \text{ gal/yr}$$

**Retrofit:** For example, a new spray nozzle with 0.98 gal/min flow replacing a nozzle with 2.14 gal/min flow at a large institutional establishments with a cafeteria equals

$$= (2.14 - 0.98) * 60 * 3 * 312$$

$$= 65,146 \text{ gal/yr}$$

**DEEMED O&M COST ADJUSTMENT CALCULATION**

N/A

<sup>277</sup>Baseline for TOS programs is calculated using the maximum flow rate for each product class in 10 CFR 431.266, Energy Efficiency Program for Certain Commercial and Industrial Equipment weighted by estimated 2018 shipments for each product class from Table 3.6.1: U.S. DOE, “Technical Support Document: Energy Efficiency Program for Consumer Products and Commercial and Industrial Equipment: Commercial Prerinse Spray Valves,” December 2015.

<sup>278</sup> Average flow rate of spray valve replaced through direct install programs from DNV-GL, “Impact Evaluation of National Grid Rhode Island C&I Prescriptive Gas Pre-Rinse Spray Valve Measure – Final Report,” September 30, 2014, page 6-6.

<sup>279</sup> A new pre-rinse spray valve is assumed to be 20% more efficient than the federal standard.

<sup>280</sup> Hours primarily based on PG& E savings estimates, algorithms, sources (2005), Food Service Pre-Rinse Spray Valves with review of 2010 Ohio Technical Reference Manual and Act on Energy Business Program Technical Resource Manual Rev05.

<sup>281</sup> Average ISR for pre-rinse spray valves distributed to ComEd Small Business Kit customers in CY2018, CY2019, and CY2020. ISR was calculated based on 262 telephone surveys from restaurant and fire station participants. Please see file “SB Kits Survey Analysis TRMv10 Support.xlsx”

**MEASURE CODE: CI-FSE-SPRY-V08-220101**

**REVIEW DEADLINE: 1/1/2026**

## 4.2.12 Infrared Charbroiler

### DESCRIPTION

This measure applies to natural gas fired charbroilers that utilize infrared burners installed in a commercial kitchen. This measure was developed to be applicable to the following program types: TOS. If applied to other program types, the measure savings should be verified.

### DEFINITION OF EFFICIENT EQUIPMENT

To qualify for this measure the installed equipment must be a new natural gas charbroiler with infrared burners.

### DEFINITION OF BASELINE EQUIPMENT

The baseline equipment is an existing natural gas charbroiler without infrared burners.

### DEEMED LIFETIME OF EFFICIENT EQUIPMENT

The expected measure life is assumed to be 12 years.<sup>282</sup>

### DEEMED MEASURE COST

The incremental capital cost for this measure is \$2173.<sup>283</sup>

### LOADSHAPE

N/A

### COINCIDENCE FACTOR

N/A

---



---

### Algorithm

---

### CALCULATION OF SAVINGS

#### ELECTRIC ENERGY SAVINGS

N/A

#### SUMMER COINCIDENT PEAK DEMAND SAVINGS

N/A

#### FOSSIL FUEL SAVINGS

Custom calculation below, otherwise use deemed value of 707 therms based on default values.<sup>284</sup>

$$\Delta Therms = \frac{(\Delta PreheatEnergy + \Delta CookingEnergy) * Days}{100,000}$$

$$\Delta PreheatEnergy = (PreheatRate_{Base} - PreheatRate_{EE}) * Preheats * \frac{PreheatTime}{60}$$

---

<sup>282</sup> Lifecycle determined from Food Service Technology Center Gas Broiler Life-Cycle Cost Calculator and from FSTC Broiler Technology Assessment.

<sup>283</sup> See 'Arkansas Deemed TRM Table for GasFoodService.xls' from v3.0 Arkansas Technical Reference Manual.

<sup>284</sup> Assumptions derived from Food Service Technology Center Gas Broiler Life-Cycle Cost Calculator and from FSTC Broiler Technology Assessment, Section 4: Broilers.



$$\Delta\text{CookingEnergy} = (\text{InputRate}_{\text{Base}} - \text{InputRate}_{\text{EE}}) * (\text{Duty} * \text{Hours})$$

Where:

- Days = Annual days of operation  
= Custom or if unknown, use 312 days per year<sup>285</sup>
- 100,000 = Btu to therms conversion factor
- PreheatRate<sub>Base</sub> = Preheat energy rate of baseline charbroiler  
= 64,000 Btu/hr
- PreheatRate<sub>EE</sub> = Preheat energy rate of infrared charbroiler  
= Custom or if unknown, use 54,000 Btu/hr
- Preheats = Number of preheats per day  
= Custom or if unknown, use 1 preheat per day
- PreheatTime = Length of one preheat  
= Custom or if unknown, use 15 minutes per preheat<sup>286</sup>
- 60 = Minutes to hours conversion factor
- InputRate<sub>Base</sub> = Input energy rate of baseline charbroiler  
= 140,000 Btu/hr
- InputRate<sub>EE</sub> = Input energy rate of infrared charbroiler  
= Custom or if unknown, use 105,000 Btu/hr
- Duty = Duty cycle of charbroiler (%)  
= Custom or if unknown, use 80%<sup>287</sup>
- Hours = Average daily hours of operation  
= Custom or if unknown, use 8 hours per day

**WATER IMPACT DESCRIPTIONS AND CALCULATION**

N/A

**DEEMED O&M COST ADJUSTMENT CALCULATION**

N/A

**MEASURE CODE: CI-FSE-IRCB-V03-240101**

**REVIEW DEADLINE: 1/1/2028**

---

<sup>285</sup>Typical annual operating time from FSTC Broiler Technology Assessment, Table 4.3.

<sup>286</sup>Typical preheat time from FSTC Broiler Technology Assessment.

<sup>287</sup> Duty cycle from FSTC Broiler Technology Assessment, Table 4.3.

### 4.2.13 Rotisserie Oven

**DESCRIPTION**

This measure applies to efficient natural gas fired high efficiency rotisserie ovens utilizing infrared burners or design approaches that combine radiative heat exchangers and convection heating and installed in a commercial kitchen.

This measure was developed to be applicable to the following program types: TOS. If applied to other program types, the measure savings should be verified.

**DEFINITION OF EFFICIENT EQUIPMENT**

To qualify for this measure the installed equipment must be a new highly efficient natural gas rotisserie oven as defined by the program.

**DEFINITION OF BASELINE EQUIPMENT**

The baseline equipment is a new standard natural gas rotisserie oven.

**DEEMED LIFETIME OF EFFICIENT EQUIPMENT**

The expected measure life is assumed to be 12 years.<sup>288</sup>

**DEEMED MEASURE COST**

The incremental capital cost for this measure is \$2665.<sup>289</sup>

**LOADSHAPE**

N/A

**COINCIDENCE FACTOR**

N/A

---



---

**Algorithm**

---



---

**CALCULATION OF SAVINGS**

**ELECTRIC ENERGY SAVINGS**

N/A

**SUMMER COINCIDENT PEAK DEMAND SAVINGS**

N/A

**FOSSIL FUEL SAVINGS**

Custom calculation below based on Food Service Technology Center calculator, otherwise use deemed value of 599 therms, based on default values.

$$\Delta Therms = \frac{(InputRate_{Base} - InputRate_{EE}) * Duty * Days * HoursDay}{100,000}$$

Where:

---

<sup>288</sup>Lifecycle determined from Food Service Technology Center Gas Oven Life-Cycle Cost Calculator.

<sup>289</sup>See ‘Arkansas Deemed TRM Table for GasFoodService.xls’ from v3.0 Arkansas Technical Reference Manual.

InputRate <sub>Base</sub>	= Energy input rate of baseline rotisserie oven (Btu/hr) = Custom of if unknown, use 90,000 Btu/hr <sup>290</sup>
InputRate <sub>EE</sub>	= Energy input rate of efficient rotisserie oven (Btu/hr) = Custom of if unknown, use 50,000 Btu/hr <sup>291</sup>
Duty	= Duty cycle of rotisserie oven (%) = Custom or if unknown, use 60% <sup>292</sup>
Days	= Days per year rotisserie oven is operating = Custom of if unknown assume 312 (6 days a week, 52 weeks per year) <sup>293</sup>
HoursDay	= Typical daily operating hours of rotisserie oven = Custom or if unknown, assume 8 hours <sup>294</sup>
100,000	= Btu to therms conversion factor

**WATER IMPACT DESCRIPTIONS AND CALCULATION**

N/A

**DEEMED O&M COST ADJUSTMENT CALCULATION**

N/A

**MEASURE CODE: CI-FSE-IROV-V04-240101**

**REVIEW DEADLINE: 1/1/2027**

---

<sup>290</sup> Median rated energy input for rotisserie ovens from FSTC Oven Technology Assessment, Section 7: Ovens, Table 7.2.

<sup>291</sup> Infrared energy input rate calculated based on efficient energy input rate of 50,000 Btu/hr, baseline cooking efficiency of 25%, and infrared cooking efficiency of 45%. Efficiencies and rates derived from FSTC Gas Rotisserie Oven Test Reports and FSTC Oven Technology Assessment.

<sup>292</sup> Duty cycle from Food Service Technology Center Oven Technical Assessment, Table 7.2.

<sup>293</sup> Typical operating hours based on oven operating schedule of 8 hours per day, 6 days per week, 52 weeks per year, provided in Food Service Technology Center Oven Technical Assessment, Table 7.2.

<sup>294</sup> Food Service Technology Center Oven Technical Assessment, Table 7.2.

#### 4.2.14 Infrared Salamander Broiler

**DESCRIPTION**

This measure applies to natural gas fired high efficiency salamander broilers utilizing infrared burners installed in a commercial kitchen.

This measure was developed to be applicable to the following program types: TOS. If applied to other program types, the measure savings should be verified.

**DEFINITION OF EFFICIENT EQUIPMENT**

To qualify for this measure the installed equipment must be a new natural gas salamander broiler with infrared burners

**DEFINITION OF BASELINE EQUIPMENT**

The baseline equipment is an existing natural gas salamander broiler without infrared burners

**DEEMED LIFETIME OF EFFICIENT EQUIPMENT**

The expected measure life is assumed to be 12 years.<sup>295</sup>

**DEEMED MEASURE COST**

The incremental capital cost for this measure is \$1,000.<sup>296</sup>

**LOADSHAPE**

N/A

**COINCIDENCE FACTOR**

N/A

---



---

**Algorithm**

---



---

**CALCULATION OF SAVINGS**

**ELECTRIC ENERGY SAVINGS**

N/A

**SUMMER COINCIDENT PEAK DEMAND SAVINGS**

N/A

**FOSSIL FUEL SAVINGS**

Custom calculation below based on Food Service Technology Center calculator, otherwise use deemed value of 240 therms, based on defaults.

$$\Delta Therms = \frac{(InputRate_{Base} - InputRate_{EE}) * Duty * Days * HoursDay}{100,000}$$

Where:

---

<sup>295</sup> Lifecycle determined from Food Service Technology Center Gas Broiler Life-Cycle Cost Calculator and from FSTC Broiler Technology Assessment.

<sup>296</sup>See ‘Arkansas Deemed TRM Table for GasFoodService.xls’ from v3.0 Arkansas Technical Reference Manual.

InputRate <sub>Base</sub>	= Rated energy input rate of baseline salamander broiler (Btu/hr) = 38,500 Btu/hr <sup>297</sup>
InputRate <sub>EE</sub>	= Rated energy input rate of infrared salamander broiler (Btu/hr) = Custom; or if unknown, use 24,750 Btu/hr <sup>298</sup>
Duty	= Duty cycle of salamander broiler (%) = Custom; or if unknown, use 70% <sup>299</sup>
Days	= Days per year salamander broiler is operating = Custom of if unknown assume 312 (6 days a week, 52 weeks per year) <sup>300</sup>
HoursDay	= Typical daily operating hours of salamander broiler = Custom; or if unknown, assume 8 hours <sup>301</sup>
100,000	= Btu to therms conversion factor

**WATER IMPACT DESCRIPTIONS AND CALCULATION**

N/A

**DEEMED O&M COST ADJUSTMENT CALCULATION**

N/A

**MEASURE CODE: CI-FSE-IRBL-V03-240101**

**REVIEW DEADLINE: 1/1/2028**

---

<sup>297</sup> Median rated energy input for salamander broilers from FSTC Broiler Technology Assessment, Section 4: Broilers, Table 4.3.

<sup>298</sup> Calculated energy input rate based on baseline energy input rate of 38,500 Btu/hr, baseline cooking efficiency of 22.5%, and infrared cooking efficiency of 35%.

<sup>299</sup> Duty cycle from Food Service Technology Center Broiler Technical Assessment, Table 4.3.

<sup>300</sup> Typical operating hours based on oven operating schedule of 8 hours per day, 6 days per week, 52 weeks per year, provided in Food Service Technology Center Oven Technical Assessment, Table 7.2.

<sup>301</sup> Food Service Technology Center Broiler Technical Assessment, Table 4.3.

## 4.2.15 Infrared Upright Broiler

### DESCRIPTION

This measure applies to natural gas fired high efficiency upright broilers utilizing infrared burners and installed in a commercial kitchen.

This measure was developed to be applicable to the following program types: TOS. If applied to other program types, the measure savings should be verified.

### DEFINITION OF EFFICIENT EQUIPMENT

To qualify for this measure the installed equipment must be a new natural gas upright broiler with infrared burners.

### DEFINITION OF BASELINE EQUIPMENT

The baseline equipment is an existing natural gas upright broiler without infrared burners.

### DEEMED LIFETIME OF EFFICIENT EQUIPMENT

The expected measure life is assumed to be 12 years.<sup>302</sup>

### DEEMED MEASURE COST

The incremental capital cost for this measure is \$4,400.<sup>303</sup>

### LOADSHAPE

N/A

### COINCIDENCE FACTOR

N/A

---



---

### Algorithm

---



---

### CALCULATION OF SAVINGS

#### ELECTRIC ENERGY SAVINGS

N/A

#### SUMMER COINCIDENT PEAK DEMAND SAVINGS

N/A

#### FOSSIL FUEL SAVINGS

Custom calculation below based on Food Service Technology Center calculator, otherwise use deemed value of 943 therms based on default values.

$$\Delta Therms = \frac{(InputRate_{Base} - InputRate_{EE}) * Duty * Days * HoursDay}{100,000}$$

Where:

---

<sup>302</sup> Lifecycle determined from Food Service Technology Center Gas Broiler Life-Cycle Cost Calculator and from FSTC Broiler Technology Assessment.

<sup>303</sup>See 'Arkansas Deemed TRM Table for GasFoodService.xls' from v3.0 Arkansas Technical Reference Manual.

InputRate <sub>Base</sub>	= Rated energy input rate of baseline upright broiler (Btu/hr) = 144,000 Btu/hr <sup>304</sup>
InputRate <sub>EE</sub>	= Rated energy input rate of infrared upright broiler (Btu/hr) = Custom; or if unknown, use 90,000 Btu/hr <sup>305</sup>
Duty	= Duty cycle of upright broiler (%) = Custom; or if unknown, use 70% <sup>306</sup>
Days	= Days per year upright broiler is operating = Custom of if unknown assume 312 (6 days a week, 52 weeks per year) <sup>307</sup>
HoursDay	= Typical daily operating hours of upright broiler = Custom; or if unknown, assume 8 hours <sup>308</sup>
100,000	= Btu to therms conversion factor

**WATER IMPACT DESCRIPTIONS AND CALCULATION**

N/A

**DEEMED O&M COST ADJUSTMENT CALCULATION**

N/A

**MEASURE CODE: CI-FSE-IRUB-V03-240101**

**REVIEW DEADLINE: 1/1/2028**

---

<sup>304</sup> Baseline energy input rate calculated based on efficient energy input rate of 90,000 Btu/hr, baseline cooking efficiency of 25%, and infrared cooking efficiency of 40%.

<sup>305</sup> Median rated energy input for upright broilers from FSTC Broiler Technology Assessment, Section 4.0: Broiler, Table 4.3.

<sup>306</sup> Duty cycle from Food Service Technology Center Broiler Technical Assessment, Table 4.3.

<sup>307</sup> Typical operating hours based on oven operating schedule of 8 hours per day, 6 days per week, 52 weeks per year, provided in Food Service Technology Center Oven Technical Assessment, Table 7.2.

<sup>308</sup> Food Service Technology Center Broiler Technical Assessment, Table 4.3.

## 4.2.16 Kitchen Demand Ventilation Controls

### DESCRIPTION

Installation of commercial kitchen demand ventilation controls that vary the ventilation based on cooking load and/or time of day.

IECC 2018 and 2021 specifies that Kitchen Demand Control Ventilation is a mandatory compliance pathway for systems over 5,000 CFM of exhaust airflow. As stated, each kitchen exhaust hood shall comply with one of the following:

- Not < 50% of all replacement air shall be transfer air that would otherwise be exhausted.
- Demand ventilation systems on not < 75% of the exhaust air that are configured to provide not less than 50% reduction in exhaust and replacement air system airflow rates including controls necessary to modulate airflow in response to appliance operation and maintain full capture and containment of smoke, effluent, and combustion products during cooking and idle.
- Listed energy recovery devices with a sensible heat recovery effectiveness not < 40% on not < 50% of the total exhaust airflow.

If one of these alternate compliance options is met, kitchen demand ventilation controls would not be required by code; however, in these situations the demand ventilation controls would be considered redundant and the energy savings would likely be reduced. As a result, this measure is only applicable to new kitchens/systems under 5,000 CFM of exhaust airflow.

This measure was developed to be applicable to the following program types: NC, RF, TOS. If applied to other program types, the measure savings should be verified.

### DEFINITION OF EFFICIENT EQUIPMENT

To qualify for this measure the installed equipment must be a control system that varies the exhaust rate of kitchen ventilation (exhaust and/or makeup air fans) based on the energy and effluent output from the cooking appliances (i.e., the more heat and smoke/vapors generated, the more ventilation needed). There are three main demand control ventilation systems available that can achieve this type of modulation:

- Temperature sensors only. These systems ramp ventilation up and down based solely on the temperature from the cooking activity as measured in the ductwork or capture tank of the hood.
- Temperature and optical sensors. These systems offer the same functionality as systems with only temperature sensors plus the ability to change the ventilation rate based on the presence of smoke or steam.
- Temperature and infrared cooking sensors. These systems offer the same functionality as systems with only temperature sensors plus the ability to measure ventilation up and down based on when cooking starts.

### DEFINITION OF BASELINE EQUIPMENT

The baseline equipment is kitchen ventilation that has constant speed ventilation motor.

### DEEMED LIFETIME OF EFFICIENT EQUIPMENT

The expected measure life is assumed to be 20 years.<sup>309</sup>

---

<sup>309</sup> “Commercial Kitchen Ventilation: An Energy Efficiency Program Administrator’s Guide to Demand Control Ventilation”, CEE, October 2010 (pg. 9). The 20-year measure life estimate is based on interviews with manufacturer and industry experts.



**DEEMED MEASURE COST**

The incremental capital cost for this measure is:<sup>310</sup>

Measure Category	Incremental Cost \$/HP of fan
DVC Control Retrofit	\$1,992
DVC Control New	\$1,180

**LOADSHAPE**

Loadshape C23 - Commercial Ventilation

**COINCIDENCE FACTOR**

The measure has deemed peak kW savings therefore a coincidence factor does not apply.

---

**Algorithm**

---

**CALCULATION OF SAVINGS**

Annual energy use was based on monitoring results from five different types of sites, as summarized in PG&E Food Service Equipment work paper.

**ELECTRIC ENERGY SAVINGS**

kWh savings are assumed to be 4423 kWh per horsepower of the fan.<sup>311</sup>

**SUMMER COINCIDENT PEAK DEMAND SAVINGS**

kW savings are assumed to be 0.551 kW per horsepower of the fan.<sup>312</sup>

**FOSSIL FUEL SAVINGS**

$$\Delta \text{Therms} = \text{CFM} * \text{HP} * \text{Annual Heating Load} / (\text{Eff}(\text{heat}) * 100,000)$$

Where:

- CFM = the average airflow reduction with ventilation controls per hood  
= 430 cfm/HP<sup>313</sup>
- HP = actual if known, otherwise assume 9.65 HP<sup>314</sup>

---

<sup>310</sup> The incremental costs were derived from Southern California Edison (SCE) program data on 72 demand control kitchen ventilation project installations between 2013 and 2017 (see; "SCE13CC008\_ Exhaust\_Hood\_DCKV\_Exhaust\_CFM\_and\_Cost\_Field\_Data.xlsx"). For reference, the baseline measure costs were factored out accordingly, being obtained from costs for five kitchen exhaust fans from RSMeans online in 2017. For more detail on the source of these cost estimates, please see the California eTRM – Exhaust Hood Demand Controlled Ventilation, Commercial measure (SWFS012-01), March 4, 2020.

<sup>311</sup> Based on data provided in Southern California Edison Workpaper "Commercial Kitchen Exhaust Hoods Demand Controlled Ventilation, June 11, 2014..

<sup>312</sup> Based on data provided in Southern California Edison Workpaper "Commercial Kitchen Exhaust Hoods Demand Controlled Ventilation, June 11, 2014. Normalized demand reduction over 11 sites was 0.612 kW/HP. Applying a 0.9 CF results in a coincident demand reduction of 0.551 kW/HP.

<sup>313</sup> Based on data provided in PGE Workpaper, Commercial Kitchen Demand Ventilation Controls, PGECOFST116, June 1, 2009. See 'Kitchen DCV.xls' for details.

<sup>314</sup> Average of 72 study sites in Southern California Edison Workpaper "Commercial Kitchen Exhaust Hoods Demand Controlled Ventilation, June 11, 2014.

Annual Heating Load = Annual heating energy required to heat fan exhaust make-up air, Btu/cfm dependent on location:<sup>315</sup>

Zone	Annual Heating Load, Btu/cfm
1 (Rockford)	154,000
2-(Chicago)	144,000
3 (Springfield)	132,000
4-(Belleville)	102,000
5-(Marion)	104,000

Eff(heat) = Heating Efficiency  
 = actual if known, otherwise assume 80%<sup>316</sup>  
 100,000 = conversion from Btu to Therm

**For example**, a kitchen hood in Rockford, IL with a 9.65 HP ventilation motor  
 $\Delta$ Therms =  $430 * 9.65 * 154,000 / (0.80 * 100,000)$   
 = 7,988 Therms

**WATER IMPACT DESCRIPTIONS AND CALCULATION**

N/A

**DEEMED O&M COST ADJUSTMENT CALCULATION**

N/A

**MEASURE CODE: CI-FSE-VENT-V06-240101**

**REVIEW DEADLINE: 1/1/2028**

<sup>315</sup> Food Service Technology Center Outside Air Load Calculator, with inputs of one cfm, and hours from Commercial Kitchen Demand Ventilation Controls (Average 17.8 hours a day 4.45 am to 10.30 pm). Savings for Rockford, Chicago, and Springfield were obtained from the calculator; values for Belleville and Marion were obtained by using the average savings per HDD from the other values.

<sup>316</sup>Work Paper WPRRSGNGRO301 CLEAResult"Boiler Tune-Up" which cites Focus on Energy Evaluation Business Programs: Deemed Savings Manual V1.0, PA Consulting, KEMA, March 22, 2010.

## 4.2.17 Pasta Cooker

### DESCRIPTION

This measure applies to natural gas fired dedicated pasta cookers as determined by the manufacturer and installed in a commercial kitchen.

This measure was developed to be applicable to the following program types: TOS. If applied to other program types, the measure savings should be verified.

### DEFINITION OF EFFICIENT EQUIPMENT

To qualify for this measure the installed equipment must be a new natural gas fired pasta cooker.

### DEFINITION OF BASELINE EQUIPMENT

The baseline equipment is an existing natural gas fired stove where pasta is cooked in a pan.

### DEEMED LIFETIME OF EFFICIENT EQUIPMENT

The expected measure life is assumed to be 12.<sup>317</sup>

### DEEMED MEASURE COST

The incremental capital cost for this measure is \$2,400.<sup>318</sup>

### LOADSHAPE

N/A

### COINCIDENCE FACTOR

N/A

---



---

### Algorithm

---



---

### CALCULATION OF SAVINGS

#### ELECTRIC ENERGY SAVINGS

N/A

#### SUMMER COINCIDENT PEAK DEMAND SAVINGS

N/A

#### FOSSIL FUEL SAVINGS

The annual natural gas energy savings from this measure is a deemed value equaling 1380 Therms.<sup>319</sup>

### WATER IMPACT DESCRIPTIONS AND CALCULATION

N/A

---

<sup>317</sup>See 'Arkansas Deemed TRM Table for GasFoodService.xls' from v3.0 Arkansas Technical Reference Manual.

<sup>318</sup>Ibid.

<sup>319</sup> See 'Arkansas Deemed TRM Table for GasFoodService.xls' from v3.0 Arkansas Technical Reference Manual.

**DEEMED O&M COST ADJUSTMENT CALCULATION**

N/A

**MEASURE CODE: CI-FSE-PCOK-V03-240101**

**REVIEW DEADLINE: 1/1/2028**

## 4.2.18 Rack Oven - Double Oven

### DESCRIPTION

This measure applies to natural gas fired high efficiency rack oven - double oven installed in a commercial kitchen.

This measure was developed to be applicable to the following program types: TOS. If applied to other program types, the measure savings should be verified.

### DEFINITION OF EFFICIENT EQUIPMENT

To qualify for this measure the installed equipment must be a new natural gas rack oven - double oven with a baking efficiency  $\geq 56\%$ .<sup>320</sup>

### DEFINITION OF BASELINE EQUIPMENT

The baseline equipment is an existing natural gas rack oven – double oven with a baking efficiency  $<51\%$ .<sup>321</sup>

### DEEMED LIFETIME OF EFFICIENT EQUIPMENT

The expected measure life is assumed to be 12 years.<sup>322</sup>

### DEEMED MEASURE COST

The incremental capital cost for this measure is \$3,000.<sup>323</sup>

### LOADSHAPE

N/A

### COINCIDENCE FACTOR

N/A

---

---

### Algorithm

---

---

### CALCULATION OF SAVINGS

#### ELECTRIC ENERGY SAVINGS

N/A

#### SUMMER COINCIDENT PEAK DEMAND SAVINGS

N/A

#### FOSSIL FUEL SAVINGS

Custom calculation below, otherwise use deemed value of 1930 therms based on default values.<sup>324</sup>

---

<sup>320</sup> Based on average test data per ASTM F2093 used in California Foodservice Rack Oven Memo 09202019 Attachment supporting the CAeTRM.

<sup>321</sup> Ibid.

<sup>322</sup> Lifecycle determined from Food Service Technology Center Gas Rack Oven Life-Cycle Cost Calculator and from FSTC Oven Technology Assessment.

<sup>323</sup> See 'Arkansas Deemed TRM Table for GasFoodService.xls' from v3.0 Arkansas Technical Reference Manual.

<sup>324</sup> Assumptions derived from Food Service Technology Center Gas Rack Oven Life-Cycle Cost Calculator, FSTC Oven Technology Assessment, Section 7: Ovens, and from FSTC Gas Double Rack Oven Test Reports.

$$\Delta Therms = \Delta DailyPreheatEnergy + \Delta DailyIdleEnergy + \Delta DailyCookingEnergy) * Days/100,000$$

$$\Delta DailyPreheatEnergy = DailyPreheats * (PreheatEnergyBase - PreheatEnergyEE)$$

$$\Delta DailyIdleEnergy = (IdleRateBase * (Hours - \frac{LB}{PCBase} - \frac{DailyPreheats * PreheatTime}{60})) - (IdleRateEE * (Hours - \frac{LB}{PCEE} - \frac{DailyPreheats * PreheatTime}{60}))$$

$$\Delta DailyCookingEnergy = \left( \frac{LB * EFOOD}{EffBase} \right) - \left( \frac{LB * EFOOD}{EffEE} \right)$$

Where<sup>325</sup>:

DailyPreheats	= Number of preheats per day = Custom; or if unknown, 1
PreheatEnergy <sub>EE</sub>	= Preheat energy of energy efficient rack oven – double oven = Custom; or if unknown 65,758 Btu
PreheatEnergy <sub>Base</sub>	= Preheat energy of baseline rack oven – double oven = Custom; or if unknown 90,009 Btu
IdleRate <sub>EE</sub>	=Idle rate of energy efficient rack oven – double oven =Custom; or if unknown, 24,600 Btu/hr
IdleRate <sub>Base</sub>	=Idle rate of baseline rack oven – double oven =Custom; or if unknown, 36,909 Btu/hr
LB	= Pounds of food cooked per day = Custom; or if unknown, 1,200 lb/day
PC <sub>EE</sub>	= Production capacity of energy efficient rack oven – double oven = Custom; or if unknown, 279 lbs/hour
PC <sub>Base</sub>	= Production capacity of baseline rack oven – double oven = Custom; or if unknown, 272 lbs/hour
PreheatTime	= Length of a single preheat = Custom; or if unknown, 20 minutes
60	= Conversion of minutes to hour
EFOOD	= ASTM energy to food ratio, the energy absorbed by food during cooking = 235 Btu/lb
Eff <sub>EE</sub>	= Cooking efficiency of energy efficient rack oven – double oven = Custom; or if unknown, use 56%
Eff <sub>Base</sub>	= Cooking efficiency of baseline rack oven – double oven = Custom; or if unknown, 51%
Hours	= Average daily hours of operation

<sup>325</sup> Unless noted otherwise, assumptions consistent with Southern California Gas Company (SCG). 2019. "Reformulated baseline efficiencies and eligibility requirements for Commercial Rack Oven workpaper SWFS014-01." Memorandum submitted to Peter Biermayer (Energy Division) and Sue Haselhorst (Ex Ante Review Team). September 18.

100,000 = Custom; or if unknown, use 12 hours<sup>326</sup>  
= Btu to therms conversion factor

**WATER IMPACT DESCRIPTIONS AND CALCULATION**

N/A

**DEEMED O&M COST ADJUSTMENT CALCULATION**

N/A

**MEASURE CODE CI-FSE-RKOV-V03-240101**

**REVIEW DEADLINE: 1/1/2028**

---

<sup>326</sup> Typical operating hours based on oven operating schedule of 12 hours per day, 6 days per week, 52 weeks per year, provided in FSTC Gas Double Rack Oven Test Reports on various double rack ovens.

4.2.19 ENERGY STAR Electric Convection Oven – Removed in v11, consolidated with 4.2.5 ENERGY STAR Convection Oven



## 4.2.20 Efficient Dipper Wells

### DESCRIPTION

Various commercial food establishments utilize dipper wells that continuously run fresh water over utensils. One example is an ice cream shop that places the ice cream scooper in the dipper well, in order to keep them clean and avoid cross-mixing of flavors. Some restaurants may utilize a dipper well to store potato slicers and butter-ball scoopers. Coffee shops often utilize a dipper well for storage of drink thermometers and mixing spoons. Bars may utilize a dipper well for storage of mixing spoons, strainers, ice tongs, and other utensils. Dipper wells may also be found in grocery stores, school cafeterias, and other institutional kitchens.

Commercial kitchen equipment vendors have developed water-efficient dipper well designs which eliminate the continuous water flow. The efficient design recirculates the water in the well rather than continuously adding fresh water. For bacteriological control some designs utilize a chemical disinfectant (i.e., bleach) and some utilize ozone.

The calculated water savings (in gallons/year) will, in turn, be used to calculate electricity savings (in kWh/year) after applying the appropriate energy factor.

Heated dipper wells are not included in this characterization as the electric penalty associated with the electric resistance heating removes all potential electric savings due to water characterization.

This measure was developed to be applicable to the following program types; EREP and TOS. If applied to other program types, the measure savings should be verified.

### DEFINITION OF EFFICIENT EQUIPMENT

The efficient equipment is assumed to be a dipper well that does not continuously run. One type of water-efficient dipper well design recirculates the water in the basin, rather than continuously adding fresh water. The efficient design will employ chemical or ozone sanitation.

Other types of water-efficient dipper well utilize a spatula or shower, where water is only applied to the surface of the utensil when a pressure switch is activated. The dimensions of water-efficient dipper wells will vary, depending on the number of utensils that need to be handled. The flow rate of the spigot is similar between the baseline equipment and the efficient equipment. However, that flow rate only occurs when the well initially fills up or the pressure switch is activated.

### DEFINITION OF BASELINE EQUIPMENT

The baseline equipment is assumed to be a dipper well providing continuously running fresh water to the utensils in the basin. As a result, there is a concurrent stream of wastewater that is continuously sent to the sewer. The dipper well typically will run during the hours of operation for the restaurant or bar. Some dipper wells will also be left on during the night when the establishment is closed.

Many dipper wells consist of two concentric tanks. Water flows into the inner tank and overflows through the perforations at the top to the outer tank, which is connected to the sewer drain. Other designs utilize just one tank, with some other means of overflow drainage to the sewer.

### DEEMED LIFETIME OF EFFICIENT EQUIPMENT

The expected measure life is assumed to be 10 years.<sup>327</sup>

---

<sup>327</sup> Alignment with existing dipper well program measure lives in California. Dipper Well Replacement Field Evaluation Report, Frontier Energy, November 2017.

[https://fishnick.com/publications/fieldstudies/Dipper\\_Well\\_Replacement\\_Field\\_Evaluation\\_ICP.pdf](https://fishnick.com/publications/fieldstudies/Dipper_Well_Replacement_Field_Evaluation_ICP.pdf)

**DEEMED MEASURE COST**

The cost for this measure is assumed to be \$450 for Early Replacement or \$300 for Time of Sale. The typical material cost for an efficient dipper well system is approximately \$150 to \$350.<sup>328</sup> The typical material cost for a baseline dipper well system is approximately \$100 to \$200.<sup>329</sup> Full installation costs, including plumbing materials, labor, and any associated controls, should be used for screening purposes.

**LOADSHAPE**

**LOADSHAPE C01 - COMMERCIAL ELECTRIC COOKING**

**COINCIDENCE FACTOR**

N/A

---



---

**Algorithm**

---



---

**CALCULATION OF SAVINGS**

Energy savings from the efficient dipper well systems are the result of reduced water consumption. There are indirect electric energy savings from reduced potable water treatment and wastewater treatment energy inputs.

**ELECTRIC ENERGY SAVINGS**

Secondary kWh Savings for Water Supply and Wastewater Treatment

The following savings should be included in the total savings for this measure, but should not be included in TRC tests to avoid double counting the economic benefit of water savings.

The electric energy savings are based indirectly on the reduced electricity usage used to provide the potable water and treat the wastewater. By applying an “Energy Factor”, the water savings (in gallons/year) can be converted to electricity savings (in kWh/year). This “Energy Factor” considers the electric energy requirements of potable water treatment plants, potable water distribution, wastewater treatment plants, and wastewater distribution.

$$\Delta kWh_{water} = \Delta Water \text{ (gallons)} / 1,000,000 * E_{water \text{ total}}$$

Where:

$$E_{water \text{ total}} = \text{IL Total Water Energy Factor (kWh/Million Gallons)}$$

$$= 5,010^{330}$$

---

<sup>328</sup> Google Shopping search for the term “water efficient dipper well”. Results include the “ConserveWell” from KaTom Restaurant Supply for \$300.

<sup>329</sup> Google Shopping search for the term “dipper well system”. Results show various baseline models that range from \$100 to \$200.

<sup>330</sup> This factor include 2571 kWh/MG for water supply based on Illinois energy intensity data from a 2012 ISAWWA study and 2439 kWh/MG for wastewater treatment based on national energy intensity use estimates. For more information please review Elevate Energy’s ‘IL TRM: Energy per Gallon Factor, May 2018 paper’.

**For example,**

$$\text{BAWU} = (\text{DWOH} * \text{AO}) / (\text{TFOG} * 1 \text{ hour}/60 \text{ min})$$

$$= [16 \text{ hours}/\text{day}] * [365 \text{ day}/\text{year}]$$

$$[0.5 \text{ gal}/\text{min}] * [1 \text{ hour}/60 \text{ min}]$$

$$= 175,200 \text{ gal}/\text{year}$$

$$\text{ECAWU} = 3,650 \text{ gal}/\text{year}$$

$$\Delta \text{Water} = \text{BAWU} - \text{ECAWU}$$

$$= 175,200 \text{ gal}/\text{year} - 3,650 \text{ gal}/\text{year}$$

$$= 171,550 \text{ gal}/\text{year}$$

$$\Delta \text{kWhwater} = \Delta \text{Water} / 1,000,000 * \text{Ewater total}$$

$$= (171,500 \text{ gal. of water}/\text{year}) / 1,000,000 * 5,010 \text{ kWh}/\text{million gallons}$$

$$= 859 \text{ kWh}/\text{year}$$

**SUMMER COINCIDENT PEAK DEMAND SAVINGS**

N/A

**FOSSIL FUEL IMPACT DESCRIPTIONS AND CALCULATION**

N/A

**WATER IMPACT DESCRIPTIONS AND CALCULATION**

The methodology for quantifying the water savings involves a direct comparison of the baseline equipment to the efficient equipment. The baseline flow rate will typically be between 0.2 gpm to 1.0 gpm.<sup>331</sup> The actual flow rate of the baseline equipment should be directly measured. This can be accomplished by recording the time required to fill a 1-gallon container (minutes per gallon); taking the inverse of that value will give the water flow rate (gallons per minute). The number of hours per day that the spigot remains flowing should be determined. This is typically coincident with the operating hours of the establishment, but the spigot could remain flowing during off hours too.

The equation for calculating the baseline annual water usage is as follows:

$$\text{BAWU} = [\text{DWOH} * \text{AO}] / [\text{TFOG} * (1 \text{ hour}/60 \text{ min})]$$

Where:

BAWU = Baseline Annual Water Usage (gal/year)

DWOH = Dipper Well Operating Hours (hours/day)

AO = Annual Operations (days/year)

TFOG = Time to Fill One Gallon (min/gal)

Estimating the efficient-case water consumption will require an understanding of how the dipper well will be used. If the efficient-case equipment utilizes a constantly circulating pool of chemically treated water, then the only water consumption is that required to fill the basin. Depending on the number of times that the basin is filled and emptied in a day, the annual water consumption for the efficient case can be calculated as follows:

$$\text{ECAWU} = \text{BV} * \text{BFPD} * \text{AO}$$

<sup>331</sup> Michael Slater and Amin Delagah, “Dipper Well Replacement Field Evaluation Report”, Frontier Energy Report #50115-R0, November 2017. Prepared for the Metropolitan Water District of Southern California. <http://www.bewaterwise.com/pdfs/ICP/2015ICP-DipperWellFrontierEnergy.pdf>

Where:

ECAWU	= Efficient Case Annual Water Usage (gal/year)
BV	= Basin Volume (gal)
BFPD	= Basin Fills Per Day (days-1)
AO	= Annual Operations (days/year)

If the efficient-case equipment utilizes a ‘shower’ that only dispenses water when the pressure switch is activated, the amount of water consumption is dependent on the number of times the ‘shower’ is actuated and the length of each ‘shower’. The Spigot Flow Rate should be similar to that of the baseline equipment (0.2 gal/min to 1.0 gal/min). However, that flow rate is only in effect for the duration that the pressure switch is pressed. This is referred to as the Time of Actuation, and it can generally be estimated as a few seconds per push. Furthermore, the number of times the shower is actuated in a day can be estimated by considering the customer sales volume of the establishment.

The annual water consumption for the efficient case can also be calculated as follows:

$$ECAWU = (SFR \times TA \times NAPD) / (60 \text{ sec/min} \times AO)$$

Where:

ECAWU	= Efficient Case Annual Water Usage (gal/year)
SFR	= Spigot Flow Rate (gal/min)
TA	= Time of Actuation (sec/push)
NAPD	= Number of Actuations per Day (push/day)
AO	= Annual Operations (days/year)

For the purposes of this measure, the Efficient Case daily water usage of 10 gal/day will be used<sup>332</sup>. At 365 days/year of usage, the ECAWU will be 3,650 gal/year.

Finally, the annual water savings per year can be calculated as follows:

$$\Delta\text{Water} = \text{BAWU} - \text{ECAWU}$$

Where:

$\Delta\text{Water}$	= Total Water Savings (gal/year)
BAWU	= Baseline Annual Water Usage (gal/year)
ECAWU	= Efficient Case Annual Water Usage (gal/year)

**DEEMED O&M COST ADJUSTMENT CALCULATION**

N/A

**MEASURE CODE CI-FSE-EDIP-V02-220101**

**REVIEW DEADLINE: 1/1/2028**

---

<sup>332</sup> Michael Slater and Amin Delagah, “Dipper Well Replacement Field Evaluation Report”, Frontier Energy Report #50115-R0, November 2017. Prepared for the Metropolitan Water District of Southern California. <http://www.bewaterwise.com/pdfs/ICP/2015ICP-DipperWellFrontierEnergy.pdf>

## 4.2.21 On-Demand Package Sealers – Provisional Measure

### DESCRIPTION

This measure consists of the replacement of standard electric package sealers with new on-demand package sealers in a retail grocery store. The sealers are used for heat-sealing plastic-wrapped packages for retail sale. The typical baseline unit uses a 550-Watt heating element and 50 Watt heat sealing bar at about 280°F or greater and maintains that temperature unless the unit is turned off when not in use.<sup>333</sup> In practice, the units are frequently left on to avoid waiting for the bar to reach operating temperature. Qualifying units use on-demand heat bars or automatic controls that turn off the unit between uses. Different configurations and brands were tested for the baseline at two grocery store chains that included a total of 199 stores.<sup>334</sup> This measure applies to grocery store, convenience store, deli, bakery, butcher, and other commercial with a demonstrated business need.

This measure was developed to be applicable to the following program types: TOS, EREP. If applied to other program types, the measure savings should be verified.

### DEFINITION OF EFFICIENT EQUIPMENT

The on-demand package sealer uses controls to turn the equipment off when it is not in use. The functionality of the baseline and on-demand system is similar. The on-demand package sealer operates similarly to the baseline but has a larger heating element. The on-demand package sealer utilizes an automatic control or pressure momentary switch control to power off the heating elements when the equipment is not in use. Controls for the on-demand unit allow the heating element to turn on only when the heating element is pushed down, or the product crosses the automatic controls. By applying pressure to the heating element or activating the automatic controls the on-demand unit engages a switch, which activates the 2,000-Watt heating element until the switch is disengaged, or for a maximum of 3 seconds. The efficient sealers use less energy overall by reducing standby electrical energy use. These machines come in stand-alone or table-top styles.

### DEFINITION OF BASELINE EQUIPMENT

The baseline package sealer consists of a heating bar and a larger heating element and is rated at approximately 550 Watts and 0.50 kW, respectively. The heating bar is used to cut the wrapping film as it contacts the heating bar. The larger heating element is used to heat up the wrapping film. When the wrapping film is heated, the film sticks to a package to seal the product. With the conventional package sealer, both heating elements are controlled to keep a constant temperature of 280°F. The units are manually turned on and off. The baseline package sealers come in two styles, a stand-alone unit and a table-top unit.

### DEEMED LIFETIME OF EFFICIENT EQUIPMENT

The expected measure life is assumed to be 10 years.<sup>335</sup>

---

<sup>333</sup> Design & Engineering Services Customer Service Organization Southern California Edison, October 2012, Vacuum-Sealing and Packaging Machines For Food Service Applications Field Test Et10sce1450, pg 1.

<sup>334</sup> The October 2012 SCE field test (mentioned above) was a study based datalogger information over six weeks of units in 199 stores.

<sup>335</sup> Based on similar equipment types, as there is not a standard for shrink wrappers listed. The Illinois TRM v9's kitchen equipment measure lives range from 5-20 years. 70% of the kitchen equipment measures have a 12 year measure life, but half of these are gas-only measures. We used Efficient Dipper Wells' measure life of 10 years as both measures save energy by replacing continuously running equipment with equipment that only runs when needed. Both On-Demand Package Sealers and Efficient Dipper Wells also may have higher regular maintenance needs than the other Kitchen equipment - to prevent clogging.

**DEEMED MEASURE COST**

The deemed measure cost for this measure varies based on unit size and type. Please see the table<sup>336</sup> below for typical costs:

Equipment Category	Tabletop Unit	Floor Unit
Baseline	\$825	\$2,349
Efficient	\$1,215	\$4,304

**LOADSHAPE**

N/A

**COINCIDENCE FACTOR**

N/A

---

**Algorithm**

---

**CALCULATION OF ENERGY SAVINGS**

**ELECTRIC ENERGY SAVINGS**

$$\Delta kWh = ((Watts_{base} * HOU)/1,000) - (((Watts_{efficient} * HOU)/1,000) * (1 - ESF))$$

Where:

Watts<sub>base</sub> = Wattage of Existing Equipment’s heating element  
 = If not known, use 600 W<sup>337</sup>

Watts<sub>efficient</sub> = Wattage of Proposed Efficient Equipment sealing element  
 = If not known, use 2,000 W<sup>338</sup>

HOU = Use known Hours of Use  
 = If hours not known, hours are selected from the fixture hours column of the Reference Table in Section 4.5 for each building type.

ESF = Energy Savings Factor  
 = If ESF not known, use 90%<sup>339</sup>

<sup>336</sup> Commercial Vacuum Sealer costs – Manual (Baseline) & Automatic. Please see pdf of <https://www.webstaurantstore.com/> data sets.

<sup>337</sup> Design & Engineering Services Customer Service Organization Southern California Edison, October 2012, Vacuum-Sealing And Packaging Machines For Food Service Applications Field Test Et10sce1450 – Note: this was a study based datalogger information over six weeks of units in 199 stores.

<sup>338</sup> Ibid

<sup>339</sup> ESF assumes On-Demand Package Sealer is actively heating 10% of the Hours of Use. The ESF source assumption is that the On-Demand sealers will be in use an average of six minutes of every hour. Currently there is no logged data that captures the total amount of time the efficient machines run, however once we get that data is available from the program, this value will be updated.

**For example**, a new on-demand package sealer replacing a baseline package sealer with unknown hours at a grocery store saves:

$$\begin{aligned} \Delta kWh &= ((600 * 5,468) / 1,000) - (((2,000 * 5,468) / 1,000) * (1 - 0.9)) \\ &= 2,187.2 \text{ kWh} \end{aligned}$$

**SUMMER COINCIDENT PEAK DEMAND SAVINGS**

$$\Delta kW = \frac{\Delta kWh}{HOU} * CF$$

Where:

CF = Coincident Factor, use 1.0.

**For example**, a new on-demand package sealer replacing a baseline package sealer with unknown hours at a grocery store saves:

$$\begin{aligned} \Delta kWh &= 2,187.2 / 5,468 * 1.0 \\ &= 0.40 \text{ kW} \end{aligned}$$

**FOSSIL FUEL SAVINGS**

N/A

**WATER AND OTHER NON-ENERGY IMPACT DESCRIPTIONS AND CALCULATION**

N/A

**DEEMED O&M COST ADJUSTMENT CALCULATION**

N/A

**MEASURE CODE: CI-FSE-ODPS-V01-220101**

**REVIEW DEADLINE: 1/1/2025**

## 4.2.22 Automatic Conveyor Broiler

### DESCRIPTION

This measure applies to natural gas fired energy efficient automatic conveyor broiler installed in a commercial kitchen. Conveyor broilers are one of the most energy intensive appliances in a commercial kitchen and energy efficient automatic conveyor broilers have potential to save energy while providing similar capacities and reducing the heat load in a kitchen<sup>340</sup>.

This measure was developed to be applicable to the following program types: TOS. If applied to other program types, the measure savings should be verified.

### DEFINITION OF EFFICIENT EQUIPMENT

To be eligible for rebates, the energy efficient natural gas fired automatic conveyor broiler must have a catalyst and an input rate less than 80 kBtu/hr or a dual stage or modulating valve with a capability of throttling the input rate below 80 kBtu/hr<sup>341</sup>.

Natural gas fired energy efficient automatic conveyor broilers equipped with electric bun grills and/or electric heating/warming elements are eligible for electric energy savings.

### DEFINITION OF BASELINE EQUIPMENT

The base case is defined as natural gas fired automatic conveyor broiler capable of maintaining a temperature above 600°F and an idle rate greater than the energy efficient replacement.

### DEEMED LIFETIME OF EFFICIENT EQUIPMENT

The expected measure life is assumed to be 12 years<sup>342</sup>.

### DEEMED MEASURE COST

The incremental capital cost varies based on the conveyor width<sup>343</sup>:

Conveyor Width (in)	IMC
18in	\$2,523
26in	\$3,146
30in	\$3,659

### LOADSHAPE

N/A

### COINCIDENCE FACTOR

Summer Peak Coincidence Factor for measure is 0.90<sup>344</sup>.

---

### Algorithm

---

<sup>340</sup> "California eTRM: Automatic Conveyor Broiler, Commercial", July 29th ,2021

<https://www.caetrm.com/measure/SWFS017/02/>

<sup>341</sup> "California eTRM: Automatic Conveyor Broiler, Commercial", July 29th ,2021 as well as "New York Standard Approach for Estimating Energy Savings from Energy Efficiency Programs: Conveyor Broiler", August 30th , 2021, Page 410.

<sup>342</sup> "California eTRM: Automatic Conveyor Broiler, Commercial", July 29th ,2021

<https://www.caetrm.com/measure/SWFS017/02/>

<sup>343</sup> Ibid.

<sup>344</sup> "California eTRM: Automatic Conveyor Broiler, Commercial", July 29th ,2021

<https://www.caetrm.com/measure/SWFS017/02/>



**CALCULATION OF ENERGY SAVINGS**

**ELECTRIC ENERGY SAVINGS**

Natural gas fired energy efficient automatic conveyor broilers equipped with electric bun grills and/or electric heating/warming elements are eligible for electric energy savings.

$$\Delta kWh = kWh_{base} - kWh_{eff}$$

$$kWh = Electrical_{IDLE}(kW) * Hours_{DAY} * Days$$

Where:

Electrical<sub>IDLE</sub>(kW) = Electrical Idle Energy Rate. See table below<sup>345</sup>. If known, use actual.

Conveyor Width (in)	Baseline Idle Energy Rate (kW)	EE Idle Energy Rate (kW)
<20in	1.84	0.20
20in -26in	1.35	0.37
>26in	4.80	1.15

Hours<sub>DAY</sub> = Daily Operating Hours. See table below. If known, use actual.

Location	Hours <sub>DAY</sub>
Smaller restaurants; 2 <sup>nd</sup> broiler in 24-hr restaurant	8 hours <sup>346</sup>
24 hour restaurant	23 hours <sup>347</sup>

Days = Days per year of operation

= Actual, default =

Location	Days
Smaller restaurants; 2 <sup>nd</sup> broiler in 24-hr restaurant	312 days <sup>348</sup>
24 hour restaurant	363 days <sup>349</sup>

**SUMMER COINCIDENT PEAK DEMAND SAVINGS**

$$\Delta kW = \Delta kWh / AnnualHours * CF$$

Where:

$\Delta kWh$  = Annual kWh savings from measure as calculated above.

$$AnnualHours = Hours_{DAY} * Days$$

= Actual. If unknown, use values listed above.

CF = Summer Peak Coincidence Factor

= 0.90

<sup>345</sup> Ibid.

<sup>346</sup> Assumptions derived from Food Service Technology Center Gas Broiler Life-Cycle Cost Calculator and from FSTC Broiler Technology Assessment, Section 4: Broilers.

<sup>347</sup> "California eTRM: Automatic Conveyor Broiler, Commercial", July 29th ,2021  
<https://www.caetrm.com/measure/SWFS017/02/>

<sup>348</sup> Typical annual operating time from FSTC Broiler Technology Assessment, Table 4.3.

<sup>349</sup> "California eTRM: Automatic Conveyor Broiler, Commercial", July 29th ,2021  
<https://www.caetrm.com/measure/SWFS017/02/>

**FOSSIL FUEL SAVINGS**

$$\Delta\text{Therms} = \Delta\text{Idle Energy} + \Delta\text{Preheat Energy} + \Delta\text{Cooking Energy}$$

$$\Delta\text{Idle Energy} = (\text{Idle Energy}_{\text{Base}} - \text{Idle Energy}_{\text{EE}})/100,000$$

$$\text{Idle Energy}_{\text{Base}} = (\text{Hour}_{\text{SDAY}} - (\text{LB}/\text{PC}_{\text{Base}}) - (\text{PRE}_{\text{TimeBase}}/60)) * \text{IDLE}_{\text{Base}}$$

$$\text{Idle Energy}_{\text{EE}} = (\text{Hour}_{\text{SDAY}} - (\text{LB}/\text{PC}_{\text{EE}}) - (\text{PRE}_{\text{TimeEE}}/60)) * \text{IDLE}_{\text{EE}}$$

Where:

LB = pounds of food cooked per day (lb/day)

PC = Production capacity (lbs/hr)

PRE<sub>TIME</sub> = Preheat time (min/day)

IDLE = Idle energy rate (Btu/hr)

*If known, use actual values, otherwise see table below:<sup>350</sup>*

Conveyor Width (in)	LB (lb/day)		PC (Lbs/hr)		PreTIME (Min)		IDLE (Btu/hr)	
	Base	EE	Base	EE	Base	EE	Base	EE
<20in	75		29	21	10	29	54,500	28,000
20in - 26in	150		48	42	8	16	78,120	47,960
>26in	110		90	86	22	12	104,000	57,000

$$\Delta\text{Preheat Energy} = (\text{PRE}_{\text{ENERGYBase}} - \text{PRE}_{\text{ENERGYEff}})$$

Where:

PRE<sub>ENERGY</sub> = Preheat energy (Btu)

$$\Delta\text{Cooking Energy} = (\text{Cooking Energy}_{\text{base}} - \text{Cooking Energy}_{\text{Eff}})/100,000$$

$$\text{Cooking Energy}_{\text{base}} = (\text{LB}/\text{PC}_{\text{Base}}) * \text{Cooking}_{\text{RateBase}}$$

$$\text{Cooking Energy}_{\text{EE}} = (\text{LB}/\text{PC}_{\text{EE}}) * \text{Cooking}_{\text{RateEE}}$$

Cooking<sub>RateBase</sub> = Baseline Cooking energy rate (Btu/hr)

Cooking<sub>RateEE</sub> = Efficient Cooking energy rate (Btu/hr)

*If known, use actual values, otherwise see table below:<sup>351</sup>*

Conveyor Width (in)	Pre <sub>ENERGY</sub> (Btu)		Cooking <sub>Rate</sub> (Btu/hr)	
	Base	EE	Base	EE
<20in	11,500	13,500	55,000	28,500
20in - 26in	14,130	14,214	78,240	50,938
>26in	42,500	13,500	111,210	67,117

<sup>350</sup> "California eTRM: Automatic Conveyor Broiler, Commercial", July 29th ,2021  
<https://www.caetrm.com/measure/SWFS017/02/>

<sup>351</sup> "California eTRM: Automatic Conveyor Broiler, Commercial", July 29th ,2021  
<https://www.caetrm.com/measure/SWFS017/02/>

**WATER AND OTHER NON-ENERGY IMPACT DESCRIPTIONS AND CALCULATION**

N/A

**DEEMED O&M COST ADJUSTMENT CALCULATION**

N/A

**MEASURE CODE: CI-FSE-ACBL-V01-230101**

**REVIEW DEADLINE: 1/1/2026**

## 4.2.23 Electric Deck Oven

### DESCRIPTION

This measure applies to new electric deck ovens installed in a commercial kitchen which have minimum heavy load cooking efficiency and maximum idle rate standards based on lab testing following ASTM F1965-99 (2010).<sup>352</sup>

This measure was developed to be applicable to the following program types: TOS. If applied to other program types, the measure savings should be verified.

### DEFINITION OF EFFICIENT EQUIPMENT

The measure case is described as a new electric deck oven which has a tested minimum heavy load cooking efficiency of 60%, and has an idle energy rate of no greater than 1.3 kW.<sup>2</sup>

Deck Oven Measure Case:

	Minimum Cooking Efficiency	Maximum Idle Energy Rate
Electric Deck Oven	60%	1.3 kW

### DEFINITION OF BASELINE EQUIPMENT

The base case electric deck oven is described as an electric deck oven with a tested average cooking efficiency which does not meet the measure case criteria.

### DEEMED LIFETIME OF EFFICIENT EQUIPMENT

The expected effective useful life of the measure electric deck oven is estimated to be 12 years.<sup>353 354</sup>

### DEEMED MEASURE COST

The incremental capital cost for this measure is \$1022 normalized per deck after considering common discounts.<sup>355</sup>

### LOADSHAPE

Loadshape C01 - Commercial Electric Cooking

### COINCIDENCE FACTOR

The summer peak coincidence factor for this measure is assumed to be 0.900<sup>356</sup>

<sup>352</sup> American Society for Testing and Materials (ASTM). 2010. *ASTM F1965-99, Standard Test Method for the Performance of Deck Ovens*. West Conshohocken (PA): ASTM International.

<sup>353</sup> Robert Mowris & Associates. 2005. *Ninth Year Retention Study of the 1995 Southern California Gas Company Commercial New Construction Program*. Prepared for Southern California Gas Company. Study ID Number 718A.

<sup>354</sup> California Public Utilities Commission (CPUC), Energy Division. 2003. *Energy Efficiency Policy Manual v 2.0*.

<sup>355</sup> Energy Solutions. 2017. "2016 IMC Analysis - For Cal TF (Energy Solutions).xls"

<sup>356</sup> Itron, Inc. 2005. *2004-2005 Database for Energy Efficiency Resources (DEER) Update Study - Final Report*. Prepared for Southern California Edison.

**Algorithm**

**CALCULATION OF ENERGY SAVINGS**

**ELECTRIC ENERGY SAVINGS<sup>357</sup>**

$$\Delta\text{Annual\_kWh} = (\Delta\text{DailyIdleEnergy} + \Delta\text{DailyPreheatEnergy} + \Delta\text{DailyCookingEnergy}) * \text{Days}$$

$$\Delta\text{DailyIdleEnergy} = (\text{IdleRate}_{\text{base}} - \text{IdleRate}_{\text{measure}}) * (\text{Hours} - \text{Food} / \text{PC} - \text{Preheats} * \text{PreheatTime} / 60)$$

$$\Delta\text{DailyPreheatEnergy} = \text{Preheats} * (\text{PreheatEnergy}_{\text{base}} - \text{PreheatEnergy}_{\text{measure}})$$

$$\Delta\text{DailyCookingEnergy} = (\text{Food} * 0.0732 / \text{CookingEff}_{\text{base}}) - (\text{Food} * 0.0732 / \text{CookingEff}_{\text{measure}})$$

Where:<sup>358 359</sup>

- Days = Annual days of operation  
= Actual, or if unknown, use 365 days per year
- Hours = Average daily hours of operation  
= Actual, or if unknown, use 12 hours
- IdleRate<sub>base</sub> = Idle energy rate of baseline electric deck oven  
= 1.90 kW
- IdleRate<sub>measure</sub> = Idle energy rate of measure electric deck oven  
= Actual, or if unknown, use 1.30 kW
- Food = Average pounds of food cooked per day  
= Actual, or if unknown, use 200 lb/day
- PC = Production Capacity of the electric deck oven  
= 60 lb/h
- Preheats = Average number of times the unit is preheated in any given day  
= Actual, or if unknown, use 1
- PreheatTime = Estimated time that the unit spends in the preheat mode  
= 30 min
- 60 = Minutes to hours conversion factor
- PreheatEnergy<sub>base</sub> = Energy use of the baseline electric deck oven during a preheat  
= Actual, or if unknown, use 6.50 kWh
- PreheatEnergy<sub>measure</sub> = Energy use of the measure electric deck oven during a preheat  
= Actual, or if unknown, use 3.00 kWh

<sup>357</sup> American Society for Testing and Materials (ASTM). 2010. *ASTM F1965-99, Standard Test Method for the Performance of Deck Ovens*. West Conshohocken (PA): ASTM International.

<sup>358</sup> Food Service Technology Center (FSTC). (n.d.) Proprietary database

<sup>359</sup> Southern California Edison (SCE). 2018. "SCE17CC012.1 A2 - Cost & Savings Calculations.xlsm."

- 0.0732 = ASTM energy to food ratio; the energy absorbed by the food during cooking in kWh/lb
- CookingEff<sub>base</sub> = Heavy load cooking energy efficiency of the baseline electric deck oven  
= Actual, or if unknown, use 40%
- CookingEff<sub>measure</sub> = Heavy load cooking energy efficiency of the measure electric deck oven  
= Actual, or if unknown, use 60%

**For example**, for a measure case electric deck oven compared to the baseline electric deck oven using the default values from above would save:

$$\Delta\text{Annual\_kWh} = (\Delta\text{DailyIdleEnergy} + \Delta\text{DailyPreheatEnergy} + \Delta\text{DailyCookingEnergy}) * \text{Days}$$

Where:

$$\begin{aligned} \Delta\text{DailyIdleEnergy} &= (1.9 - 1.3) * (12 - 200 / 60 - 1 * 30 / 60) \\ &= 4.9 \text{ kWh} \end{aligned}$$

$$\begin{aligned} \Delta\text{DailyPreheatEnergy} &= 1 * (6.5 - 3.0) \\ &= 3.5 \text{ kWh} \end{aligned}$$

$$\begin{aligned} \Delta\text{DailyCookingEnergy} &= (200 * 0.0732 / 0.40) - (200 * 0.0732 / 0.60) \\ &= 12.2 \text{ kWh} \end{aligned}$$

$$\begin{aligned} \Delta\text{Annual\_kWh} &= (4.9 + 3.5 + 12.2) * 365 \\ &= 7,519.0 \text{ kWh} \end{aligned}$$

**SUMMER COINCIDENT PEAK DEMAND SAVINGS**

$$\Delta\text{kW} = \Delta\text{kWh} / (\text{Hours} * \text{Days}) * \text{CF}$$

Where:<sup>360</sup>

- ΔkWh = Annual kWh savings from measure as calculated above
- Hours = Average daily hours of operation  
= Actual, or if unknown, use 12 hours
- Days = Annual days of operation  
= Actual, or if unknown, use 365 days per year
- CF = Summer Peak Coincidence Factor for measure  
= 0.900

<sup>360</sup> Itron, Inc. 2005. 2004-2005 Database for Energy Efficiency Resources (DEER) Update Study - Final Report. Prepared for Southern California Edison.

**For example**, for a measure case electric deck oven compared to the baseline electric deck oven using the default values from above would save:

$$\Delta kW = \Delta kWh / (\text{Hours} * \text{Days}) * CF$$

Where:

$$\Delta kWh = \text{Annual kWh savings from measure as calculated from the previous example using default values}$$

$$= 7,519.0 \text{ kWh}$$

$$\Delta kW = 7,519.0 / (12 * 365) * 0.900$$

$$= 1.545 \text{ kW}$$

**NATURAL GAS SAVINGS**

N/A

**WATER AND OTHER NON-ENERGY IMPACT DESCRIPTIONS AND CALCULATION**

N/A

**DEEMED O&M COST ADJUSTMENT CALCULATION**

N/A

**MEASURE CODE: CI-FSE-EDOV-V01-240101**

**REVIEW DEADLINE: 1/1/2028**

## 4.2.24 Gas and Electric Pressure Fryers

### DESCRIPTION

This measure applies to electric or natural gas fired pressure fryers installed in a commercial kitchen which have a minimum cooking efficiency and maximum idle rate standards based on lab testing following ASTM F1964-21 Standard Test Method for Performance of Pressure Fryers.<sup>361</sup>

This measure was developed to be applicable to the following program types: TOS and NC. If applied to other program types, the measure savings should be verified.

### DEFINITION OF EFFICIENT EQUIPMENT

The measure case is a new pressure fryer which meets the minimum cooking efficiency and maximum idle energy rate standards as tested following ASTM F1964-21.<sup>3</sup> These standards are comparable to the ENERGY STAR standards for large open deep fat fryers<sup>362</sup> and are based on the efficiency levels of the most efficient pressure fryers tested for each fuel type.

Pressure Fryer Measure Case

	Minimum Cooking Efficiency	Maximum Idle Rate
Electric Pressure Fryer	83%	0.7 kW
Gas Pressure Fryer	40%	9,000 Btu/h

### DEFINITION OF BASELINE EQUIPMENT

The base case pressure fryer is described as a pressure fryer with a tested average cooking efficiency and idle energy rate which do not meet the measure case criteria.

### DEEMED LIFETIME OF EFFICIENT EQUIPMENT

The expected lifetime of the measure equipment is assumed to be 12 years for electric pressure fryers and 11 years for gas fired pressure fryers.<sup>363 364</sup>

### DEEMED MEASURE COST

The incremental capital cost for this measure is \$6,394 for electric pressure fryers and \$4054 for gas pressure fryers.<sup>365</sup>

### LOADSHAPE

Loadshape C01 - Commercial Electric Cooking

### COINCIDENCE FACTOR

N/A

<sup>361</sup> American Society for Testing and Materials (ASTM). 2021. *ASTM F1964-21, Standard Test Method for Performance of Pressure Fryers*. West Conshohocken (PA): ASTM International.

<sup>362</sup> ENERGY STAR Commercial Fryers Program Program Requirements, version 3.0, October 2016

<sup>363</sup> California Public Utilities Commission (CPUC), Energy Division. 2020. *Energy Efficiency Policy Manual Version 6*. April. Page 35

<sup>364</sup> Guidehouse, Inc. 2020. *EMV Group A, Deliverable 16 EUL Research - Gas Fryers: Final Report*. Prepared for the California Public Utilities Commission (CPUC). June 2.

<sup>365</sup> UNPUBLISHFrontier Energy, Inc. "Pressure\_Fryer\_Workpaper\_Calculations\_Draft\_R2 2023-07-31.xlsx". May 2023.



**Algorithm**

**CALCULATION OF ENERGY SAVINGS**

**ELECTRIC ENERGY SAVINGS & FOSSIL FUEL SAVINGS**

Non Fuel-Switch Measures:

The algorithms below apply to electric fryers only.

$$\Delta\text{Annual\_kWh} = (\Delta\text{DailyIdleEnergy} + \Delta\text{DailyActiveEnergy}) * \text{Days} / 1,000$$

$$\Delta\text{DailyIdleEnergy} = (\text{IdleRate}_{\text{base}} - \text{IdleRate}_{\text{measure}}) * \text{TimeIdle}$$

$$\Delta\text{DailyActiveEnergy} = (\text{TimeActive} * \text{InputRate}_{\text{base}}) - [(\text{TimeActive} * \text{InputRate}_{\text{measure}}) * \text{CookTimeSaved}]$$

The algorithms below apply to gas fryers only.

$$\Delta\text{Annual\_Therms} = (\Delta\text{DailyIdleEnergy} + \Delta\text{DailyActiveEnergy}) * \text{Days} / 100,000$$

$$\Delta\text{DailyIdleEnergy} = (\text{IdleRate}_{\text{base}} - \text{IdleRate}_{\text{measure}}) * \text{TimeIdle}$$

$$\Delta\text{DailyActiveEnergy} = (\text{TimeActive} * \text{InputRate}_{\text{base}}) - [(\text{TimeActive} * \text{InputRate}_{\text{measure}}) * \text{CookTimeSaved}]$$

Fuel-Switch / Electrification Measures:

Fuel switch / electrification measures must product positive total energy savings (i.e., reduction in Btus at the premises) in order to qualify. The following algorithm can be used to determine eligibility:

$$\begin{aligned} \text{SiteEnergySavings (MMBTUs)} &= [\text{GasConsumptionReplaced}] - [\text{ElectricalConsumptionAdded}] \\ &= [\text{DailyIdleEnergy}_{\text{GasBase}} + \text{DailyActiveEnergy}_{\text{GasBase}}] - \\ &\quad [\text{DailyIdleEnergy}_{\text{ElectricMeasure}} + \text{DailyActiveEnergy}_{\text{ElectricMeasure}}] \end{aligned}$$

If SiteEnergySavings calculated above is positive, the measure is eligible.

The appropriate savings claims are dependent on which utilities are supporting the measure as provided in a table below:

Measure supported by:	Electric Utility claims (kWh):	Gas Utility claims (therms):
Electric utility only	SiteEnergySavings * 1,000,000/3,412	N/A
Electric and gas utility <small>(Note utilities may make alternative agreements to how savings are allocated as long as total MMBtu savings remain the same).</small>	%IncentiveElectric * SiteEnergySavings * 1,000,000/3,412	%IncentiveGas * SiteEnergySavings * 10
Gas utility only	N/A	SiteEnergySavings * 10

Where:<sup>366</sup>

- Days = Annual days of operation
- = Actual, or if unknown, use 326<sup>367</sup> days per year
- 1,000 = Wh to kWh conversion factor

<sup>366</sup> UNPUBLISHED Frontier Energy, Inc. "Pressure\_Fryer\_Workpaper\_Calculations\_Draft\_R2 2023-07-31.xlsx". May 2023.

<sup>367</sup> Fisher-Nickel, Inc. *Characterizing the Energy Efficiency Potential of Gas-Fired Commercial Foodservice Equipment*. Prepared for the California Energy Commission (CEC). CEC-500-2014-095. October 2014.

IdleRate<sub>base</sub> = Idle energy rate of baseline pressure fryer

= Actual, or if unknown, use:

Equipment Type	IdleRate
Electric	1.0 kW
Gas	10,500 Btu/h

IdleRate<sub>measure</sub> = Idle energy rate of measure pressure fryer

= Actual, or if unknown, use:

Equipment Type	IdleRate
Electric	0.7 kW
Gas	9,000 Btu/h

TimeIdle = Daily operating time that the electric pressure fryer is in idle state

= Actual, or if unknown, use 9.50 hours

TimeActive = Daily operating time the electric pressure fryer is in an active state (preheat or cook)

= Actual, or if unknown, use 2.64 hours

InputRate<sub>base</sub> = Preheat energy rate of the baseline pressure fryer

= Actual, or if unknown, use:

Equipment Type	Input Rate
Electric	16 kW
Gas	75,000 Btu/hr

InputRate<sub>measure</sub> = Preheat energy rate of the measure pressure fryer

= Actual, or if unknown, use:

Equipment Type	Input Rate
Electric	17 kW
Gas	60,000 Btu/hr

CookTimeSaved = Percentage of time saved cooking by the measure electric pressure fryer

= Can be calculated using actual values using the following algorithm:

$$\text{CookTime}_{\text{measure}} / \text{CookTime}_{\text{baseline}}$$

or

if unknown, use 0.88 for an electric pressure fryer or 0.83 for a gas pressure fryer

For fuel-switch / electrification measure use 0.88

Where:

CookTime<sub>measure</sub> = The amount of time to cook one load of the food product (min)

= Actual, or if unknown, use:

Equipment Type	CookTime (minutes)
Electric	13.5
Gas	12.7

$CookTime_{baseline}$  = The amount of time to cook on load of the food product (min)  
 = Actual, or if unknown, use:

Equipment Type	CookTime (minutes)
Electric	15.2
Gas	15.3

100,000 = Btu to therms conversion factor

**For example**, for a measure case electric pressure fryer replacing a baseline natural gas pressure fryer using the default values from the measure case in Electric Energy Savings above and the base case in Natural Gas Savings below would save:

$$\begin{aligned}
 \text{SiteEnergySavings (MMBTUs)} &= [\text{GasConsumptionReplaced}] - [\text{ElectricalConsumptionAdded}] \\
 &= [(\text{DailyIdleEnergy}_{\text{GasBase}} + \text{DailyActiveEnergy}_{\text{GasBase}}) * \text{Days} / 1,000,000] - [(\text{DailyIdleEnergy}_{\text{ElectricMeasure}} + \text{DailyActiveEnergy}_{\text{ElectricMeasure}}) * \text{Days} * 3,412 / 1,000,000] \\
 \\
 \text{DailyIdleEnergy}_{\text{GasBase}} &= \text{IdleRate}_{\text{Gasbase}} * \text{TimeIdle} \\
 &= 10,500 * 9.50 \\
 &= 99,750 \text{ btu} \\
 \\
 \text{DailyActiveEnergy}_{\text{GasBase}} &= \text{TimeActive} * \text{InputRate}_{\text{GasBase}} \\
 &= 2.64 * 75,000 \\
 &= 198,000 \text{ btu} \\
 \\
 \text{DailyIdleEnergy}_{\text{ElectricMeasure}} &= \text{IdleRate}_{\text{ElectricMeasure}} * \text{TimeIdle} \\
 &= 0.700 * 9.50 \\
 &= 6.65 \text{ kWh} \\
 \\
 \text{DailyActiveEnergy}_{\text{ElectricMeasure}} &= \text{TimeActive} * \text{InputRate}_{\text{ElectricMeasure}} * \text{CookTimeSaved} \\
 &= 2.64 * 17 * 0.88 \\
 &= 39.49 \text{ kWh} \\
 \\
 \text{SiteEnergySavings (MMBTUs)} &= [(99,750 + 198,000) * 326 / 1,000,000] - [(6.65 + 39.49) * 326 * 3,412 / 1,000,000] \\
 &= 45.9 \text{ MMBTU} \\
 \\
 \text{If supported by an electric utility} &= \text{SiteEnergySavings} * 1,000,000 / 3,412 \\
 &= 45.9 * 1,000,000 / 3,412 \\
 &= 13,440 \text{ kWh}
 \end{aligned}$$

**For example**, for a measure case electric pressures compared to the baseline gas pressure fryer using the default values from above would save:

$$\Delta\text{Annual\_Therms} = (\Delta\text{DailyIdleEnergy} + \Delta\text{DailyActiveEnergy}) * \text{Days} / 100,000$$

Where:

$$\begin{aligned} \Delta\text{DailyIdleEnergy} &= (10,500 - 9,000) * 9.50 \\ &= 14,250 \text{ Btu} \end{aligned}$$

$$\begin{aligned} \Delta\text{DailyActiveEnergy} &= (2.64 * 75,000) - ((2.64 * 60,000) * 0.83) \\ &= 66,528 \text{ Btu} \end{aligned}$$

$$\begin{aligned} \Delta\text{Annual\_Therms} &= (14,250 + 66,528) * 326 / 100,000 \\ &= 263 \text{ Therms} \end{aligned}$$

**For example**, for a measure case electric pressure fryer compared to the baseline electric pressure fryer using the default values from above would save:

$$\Delta\text{Annual\_kWh} = (\Delta\text{DailyIdleEnergy} + \Delta\text{DailyActiveEnergy}) * \text{Days}$$

Where:

$$\begin{aligned} \Delta\text{DailyIdleEnergy} &= (1.0 - 0.7) * 9.50 \\ &= 2.850 \text{ kWh} \end{aligned}$$

$$\begin{aligned} \Delta\text{DailyActiveEnergy} &= (2.64 * 16) - ((2.64 * 17) * 0.88) \\ &= 2.746 \text{ kWh} \end{aligned}$$

$$\begin{aligned} \Delta\text{Annual\_kWh} &= (2.850 + 2.746) * 326 \\ &= 1,824 \text{ kWh} \end{aligned}$$

**SUMMER COINCIDENT PEAK DEMAND SAVINGS**

N/A

**WATER AND OTHER NON-ENERGY IMPACT DESCRIPTIONS AND CALCULATION**

N/A

**DEEMED O&M COST ADJUSTMENT CALCULATION**

N/A

**COST EFFECTIVENESS SCREENING AND LOAD REDUCTION FORECASTING WHEN FUEL SWITCHING**

This measure can involve fuel switching from fossil fuel to electric.

For the purposes of forecasting load reductions due to fuel switch projects per Section 16-111.5B, changes in site energy use at the customer’s meter (using ΔkWh algorithm below), customer switching estimates, NTG, and any other adjustment factors deemed appropriate, should be used.

The inputs to cost effectiveness screening should reflect the actual impacts on the electric and fuel consumption at the customer meter and, for fuel switching measures, should therefore reflect the decrease in one fuel and increase in another, as opposed to the single savings value calculated in the “Electric and Fossil Fuel Energy Savings” section

above. Therefore in addition to the calculation of savings claimed, the following values should be used to assess the cost effectiveness of the measure.

$$\begin{aligned} \Delta\text{Therms} &= [\text{Gas Cooking Consumption Replaced}] \\ &= [((\text{IdleRate}_{\text{base}} * \text{TimeIdle}) + ((\text{TimeActive} * \text{InputRate}_{\text{base}}) * \text{CookTimeSaved})) * \text{Days} / 100,000] \end{aligned}$$

$$\begin{aligned} \Delta\text{kWh} &= [\text{Electric Cooking Consumption Added}] \\ &= - [((\text{IdleRate}_{\text{measure}} * \text{TimeIdle}) + ((\text{TimeActive} * \text{InputRate}_{\text{measure}}) * \text{CookTimeSaved})) * \text{Days} / 1,000] \end{aligned}$$

**MEASURE CODE: CI-FSE-GEPF-V01-240101**

**REVIEW DEADLINE: 1/1/2028**

## 4.2.25 Efficient Cooktops

### DESCRIPTION

This measure applies to new induction or natural gas cooktops installed in a commercial kitchen which have minimum heavy load cooking efficiency and maximum idle rate standards as defined below, based on lab testing following ASTM F1521-22 Standard Test Methods for Performance of Range Tops.<sup>368</sup>

This measure was developed to be applicable to the following program types: TOS and NC. If applied to other program types, the measure savings should be verified.

### DEFINITION OF EFFICIENT EQUIPMENT

The measure case is described as a new cooktop which has a tested minimum cooking efficiency defined below, as determined by lab testing following ASTM F1521. Where applicable, values align with ENERGY STAR program criteria.<sup>369</sup>

Induction Cooktop Measure Case:

	Minimum Cooking Efficiency
Induction Cooktop	80%
Gas Cooktop	43%

### DEFINITION OF BASELINE EQUIPMENT

The base case cooktop is described as a new natural gas or electric induction cooktop with a tested average cooking efficiency which does not meet the measure case criteria. This measure has not been designed to support electric resistance-based burner designs.

### DEEMED LIFETIME OF EFFICIENT EQUIPMENT

The expected effective useful life of the measure cooktop is estimated to be 12 years.<sup>370 371</sup>

### DEEMED MEASURE COST

The incremental capital cost for this measure is defined below, normalized per burner.<sup>372</sup>

Fuel Source	Incremental Measure Cost
Electric	\$560
Gas	\$127
Fuel-Switch	\$950

### LOADSHAPE

Loadshape C01 - Commercial Electric Cooking

<sup>368</sup> American Society for Testing and Materials (ASTM). 2018. *ASTM F1521-12, Standard Test Method for Performance of Range Tops*. West Conshohocken (PA): ASTM International.

<sup>369</sup> ENERGY STAR Commercial Electric Cooktops, version 1.0, drafted January 12, 2023

<sup>370</sup> Itron, Inc. 2005. *2004-2005 Database for Energy Efficiency Resources (DEER) Update Study - Final Report*. Prepared for Southern California Edison.

<sup>371</sup> California Public Utilities Commission (CPUC), Energy Division. 2003. *Energy Efficiency Policy Manual v 2.0*.

<sup>372</sup> Frontier Energy, Inc. 2023. "Cooktop\_Supporting\_Data\_R2 2023-07-30.xlsx".

**COINCIDENCE FACTOR**

The summer peak coincidence factor for this measure is assumed to be 0.900<sup>4</sup>

**Algorithm**

**CALCULATION OF ENERGY SAVINGS**

**ELECTRIC ENERGY SAVINGS AND FOSSIL FUEL SAVINGS<sup>373</sup>**

Non Fuel-Switch Measures:

The algorithms below apply to electric cooktops only.

$$\begin{aligned} \Delta\text{Annual\_kWh} &= (\Delta\text{DailyCookingEnergy}) * \text{Days} \\ \Delta\text{DailyCookingEnergy} &= (\text{Food} * (130 / 3,412) / \text{CookingEff}_{\text{base}}) - (\text{Food} * (130 / 3,412) / \text{CookingEff}_{\text{measure}}) \end{aligned}$$

The algorithms below apply to gas cooktops only.

$$\begin{aligned} \Delta\text{Annual\_Therms} &= (\Delta\text{DailyCookingEnergy} + \Delta\text{DailyPilotEnergy}) * \text{Days} / 100,000 \\ \Delta\text{DailyCookingEnergy} &= (\text{Food} * 130 / \text{CookingEff}_{\text{base}}) - (\text{Food} * 130 / \text{CookingEff}_{\text{measure}}) \\ \Delta\text{DailyPilotEnergy} &= (\text{PilotRate}_{\text{base}} * (24 - \text{Food} / \text{ProdCap}_{\text{base}})) - (\text{PilotRate}_{\text{measure}} * (24 - \text{Food} / \text{ProdCap}_{\text{measure}})) \end{aligned}$$

Fuel-Switch / Electrification Measures:

Fuel switch / electrification measures must product positive total energy savings (i.e., reduction in Btus at the premises) in order to qualify. The following algorithm can be used to determine eligibility:

$$\begin{aligned} \text{SiteEnergySavings (MMBTUs)} &= [\text{GasConsumptionReplaced}] - [\text{ElectricalConsumptionAdded}] \\ &= [\text{DailyCookingEnergy}_{\text{GasBase}} + \text{DailyPilotEnergy}_{\text{GasBase}}] - [\text{DailyCookingEnergy}_{\text{ElectricMeasure}}] \end{aligned}$$

It should be noted that the Food variable shall be similar from one unit to the other when fuel-switching.

If SiteEnergySavings calculated above is positive, the measure is eligible.

The appropriate savings claims are dependent on which utilities are supporting the measure as provided in a table below:

Measure supported by:	Electric Utility claims (kWh):	Gas Utility claims (therms):
Electric utility only	SiteEnergySavings * 1,000,000/3,412	N/A
Electric and gas utility <small>(Note utilities may make alternative agreements to how savings are allocated as long as total MMBtu savings remain the same).</small>	%IncentiveElectric * SiteEnergySavings * 1,000,000/3,412	%IncentiveGas * SiteEnergySavings * 10
Gas utility only	N/A	SiteEnergySavings * 10

Where:<sup>7</sup>

<sup>373</sup> Frontier Energy, Inc. 2023. "Cooktop\_Supporting\_Data\_R2 2023-07-30.xlsx"

Days = Annual days of operation  
 = Actual, or if unknown, use 326 days per year

Food = Average pounds of food cooked per day  
 = Actual, or if unknown, use 108 lb/day for an electric cooktop or 143lb/day for a gas cooktop. For fuel switching scenarios, use same Food assumption for both baseline and efficient.

130 = ASTM energy to food ratio; the energy absorbed by the food during cooking in Btu/lb

3412 = Btu to kWh conversion factor

CookingEff<sub>base</sub> = Heavy load cooking energy efficiency of the baseline cooktop  
 = Actual, or if unknown, use:

Equipment Type	Cooking Efficiency
Electric	75%
Gas	34%

CookingEff<sub>measure</sub> = Heavy load cooking energy efficiency of the measure induction cooktop  
 = Actual, or if unknown, use:

Equipment Type	Cooking Efficiency
Electric	84%
Gas	47%

100,000 = Btu to therms conversion factor

PilotRate<sub>base</sub> = Input energy rate of pilot found on baseline gas cooktop  
 = Actual, or if unknown, use 500 Btu/h

PilotRate<sub>measure</sub> = Input energy rate of pilot found on measure gas cooktop  
 = Actual, or if unknown, use 460 Btu/h

24 = Hours in a day

ProdCap<sub>base</sub> = Production Capacity of baseline gas cooktop  
 = Actual, or if unknown, use 78 lb/h

ProdCap<sub>measure</sub> = Production Capacity of measure gas cooktop



= Actual, or if unknown, use 66 lb/h

**For example**, for a measure case induction cooktop compared to the baseline induction cooktop using the default values from above would save:

$$\Delta\text{Annual\_kWh} = \Delta\text{DailyCookingEnergy} * \text{Days}$$

Where:

$$\begin{aligned} \Delta\text{DailyCookingEnergy} &= (108 * (130 / 3412) / 0.75) - (108 * (130 / 3412) / 0.84) \\ &= 0.588 \text{ kWh} \end{aligned}$$

$$\begin{aligned} \Delta\text{Annual\_kWh} &= 0.588 * 326 \\ &= 191.628 \text{ kWh} \end{aligned}$$

**For example**, for a measure case gas cooktop compared to the baseline gas cooktop using the default values from above would save:

$$\Delta\text{Annual\_Therms} = (\Delta\text{DailyCookingEnergy} + \Delta\text{DailyPilotEnergy}) * \text{Days} / 100,000$$

Where:

$$\begin{aligned} \Delta\text{DailyCookingEnergy} &= (143 * 130 / 0.34) - (143 * 130 / 0.47) \\ &= 15,123 \text{ Btu} \end{aligned}$$

$$\begin{aligned} \Delta\text{DailyPilotEnergy} &= 500 * (24 - 143 / 78) - 460 * (24 - 143 / 66) \\ &= 1040 \text{ Btu} \end{aligned}$$

$$\begin{aligned} \Delta\text{Annual\_Therms} &= (15,123 + 1040) * 326 / 100,000 \\ &= 52.69 \text{ Therms} \end{aligned}$$

**For example**, for a measure case electric induction cooktop replacing a baseline natural gas cooktop using the default values from the measure case in Electric Energy Savings above and the base case in Natural Gas Savings below would save:

$$\begin{aligned} \text{SiteEnergySavings (MMBTUs)} &= [\text{GasConsumptionReplaced}] - [\text{ElectricalConsumptionAdded}] \\ &= [(\text{DailyCookingEnergy}_{\text{GasBase}} + \text{DailyPilotEnergy}_{\text{GasBase}}) * \text{Days} / 1,000,000 - [\text{DailyCookingEnergy}_{\text{ElectricMeasure}} * \text{Days} * 3,412 / 1,000,000]] \\ \\ \text{DailyCookingEnergy}_{\text{GasBase}} &= \text{Food} * 130 / \text{CookingEff}_{\text{GasBase}} \\ &= 143 * 130 / 0.34 \\ &= 54,677 \text{ btu} \\ \\ \text{DailyPilotEnergy}_{\text{GasBase}} &= \text{PilotRate}_{\text{GasBase}} * (24 - \text{Food} / \text{ProdCap}_{\text{GasBase}}) \\ &= 500 * (24 - 143 / 78) \\ &= 11,083 \text{ btu} \\ \\ \text{DailyCookingEnergy}_{\text{ElectricMeasure}} &= \text{Food} * 130 / 3,412 / \text{CookingEff}_{\text{ElectricMeasure}} \\ &= 143 * 130 / 3,412 / 0.84 \\ &= 6.49 \text{ kWh} \\ \\ \text{SiteEnergySavings (MMBTUs)} &= [(54,677 + 11,083) * 326 / 1,000,000] - [6.49 * 326 * 3,412 / 1,000,000] \\ &= 14.2 \text{ MMBTU} \\ \\ \text{If supported by an electric utility} &= \text{SiteEnergySavings} * 1,000,000 / 3,412 \\ &= 14.2 * 1,000,000 / 3,412 \\ &= 4,169 \text{ kWh} \end{aligned}$$

**SUMMER COINCIDENT PEAK DEMAND SAVINGS**

$$\Delta kW = \Delta kWh / (\text{Hours} * \text{Days}) * CF$$

Where:<sup>374</sup>

- $\Delta kWh$  = Annual kWh savings from measure as calculated above
- Hours = Average daily hours of operation  
= Actual, or if unknown, use 6 hours
- Days = Annual days of operation  
= Actual, or if unknown, use 326 days per year
- CF = Summer Peak Coincidence Factor for measure  
= 0.900

<sup>374</sup> Itron, Inc. 2005. 2004-2005 Database for Energy Efficiency Resources (DEER) Update Study - Final Report. Prepared for Southern California Edison.

**For example**, for a measure case induction cooktop compared to the baseline induction cooktop using the default values from above would save:

$$\Delta kW = \Delta kWh / (\text{Hours} * \text{Days}) * CF$$

Where:

$$\Delta kWh = \text{Annual kWh savings from measure as calculated from the previous example using default values}$$

$$= 191.628 \text{ kWh}$$

$$\Delta kW = 191.628 / (6 * 326) * 0.900$$

$$= 0.088 \text{ kW}$$

$$\Delta \text{DailyCookingEnergy} = (93 * (130 / 3412.14) / 0.75) - (93 * (130 / 3412.14) / 0.84)$$

$$= 0.506176 \text{ kWh}$$

$$\Delta \text{Annual\_kWh} = 0.506176 * 326$$

$$= 119.458 \text{ kWh}$$

**WATER AND OTHER NON-ENERGY IMPACT DESCRIPTIONS AND CALCULATION**

N/A

**DEEMED O&M COST ADJUSTMENT CALCULATION**

N/A

**COST EFFECTIVENESS SCREENING AND LOAD REDUCTION FORECASTING WHEN FUEL SWITCHING**

This measure can involve fuel switching from fossil fuel to electric.

For the purposes of forecasting load reductions due to fuel switch projects per Section 16-111.5B, changes in site energy use at the customer’s meter (using ΔkWh algorithm below), customer switching estimates, NTG, and any other adjustment factors deemed appropriate, should be used.

The inputs to cost effectiveness screening should reflect the actual impacts on the electric and fuel consumption at the customer meter and, for fuel switching measures, should therefore reflect the decrease in one fuel and increase in another, as opposed to the single savings value calculated in the “Electric and Fossil Fuel Energy Savings” section above. Therefore in addition to the calculation of savings claimed, the following values should be used to assess the cost effectiveness of the measure.

$$\begin{aligned} \Delta \text{Therms} &= [\text{Gas Cooking Consumption Replaced}] \\ &= [((\text{PilotRate}_{\text{base}} * (24 - \text{Food} / \text{ProdCap}_{\text{base}})) + (\text{Food} * 130 / \text{CookingEff}_{\text{Gasbase}})) * \text{Days} / 100,000] \end{aligned}$$

$$\begin{aligned} \Delta \text{kWh} &= [\text{Electric Cooking Consumption Added}] \\ &= - [(\text{Food} * (130 / 3,412) / \text{CookingEff}_{\text{Elecmeasure}}) * \text{Days}] \end{aligned}$$

**MEASURE CODE: CI-FSE-INDC-V01-240101**

**REVIEW DEADLINE: 1/1/2028**

## 4.3. Hot Water

### 4.3.1 Water Heater

#### DESCRIPTION

This measure is for upgrading from minimum code to a high efficiency water heater. Storage water heaters are used to supply hot water for a variety of commercial building types. Storage capacities vary greatly depending on the application. Large consumers of hot water include (but not limited to) industries, hotels/motels and restaurants.

Tankless water heaters function similar to standard hot water heaters except they do not have a storage tank. When there is a call for hot water, the water is heated instantaneously as it passes through the heating element and then proceeds to the user or appliance calling for hot water. Tankless water heaters achieve savings by eliminating the standby losses that occur in stand-alone or tank-type water heaters and by being more efficient than the baseline storage hot water heater.

Heat pump water heaters use electricity to move heat from one place to another instead of generating heat directly and can allow for additional energy savings. Savings are presented dependent on the heating system installed in the home due to the impact of the heat pump water heater on the heating loads.

This measure was developed to be applicable to the following program types: TOS, NC. If applied to other program types, the measure savings should be verified.

#### DEFINITION OF EFFICIENT EQUIPMENT

The minimum specifications of the high efficiency equipment should be defined by the programs.

#### DEFINITION OF BASELINE EQUIPMENT

Time of Sale: The baseline condition is assumed to be a new standard water heater of same type as the existing unit being replaced, meeting the Federal Standard for  $\leq 75,000$  Btuh units and IECC 2021 for all others. If existing type is unknown, assume same water heater type as the efficient unit.

For Residential-sized  $>55$  gallon HPWH tanks, the baseline should assume the same capacity and use the appropriate standard listed below, unless it can be confirmed that the existing tank being replaced was  $<55$  gallon (and the larger tank is only being used to achieve greater efficiency of the heat pump cycle and prevent the unit from going in to resistance mode), in which case the existing unit capacity and the  $<55$  gallon algorithms should be used.

New Construction: The baseline condition is a new standard water heater of the same type as the efficient, meeting the IECC code level in place at the time the building permit was issued. As code requirements and adoption can differ from municipality to municipality, the user should verify which version of code is applicable given these constraints. Note, IECC 2021 is expected to become effective statewide in 2023. IECC 2018 is the requisite code for any projects with permitting dates spanning July 1, 2019 to the IECC 2021 effective date. Prior to July 1, 2019, IECC 2015 is the applicable code.

Note the same draw pattern (very small, low, medium and high draw) should be used for both baseline and efficient units. Definitions of draw pattern are provided below.

Equipment Type	Sub Category	Draw Pattern	Federal Standard – Uniform Energy Factor <sup>375</sup>
Residential Gas Storage Water Heaters $\leq 75,000$ Btu/h	$\leq 55$ gallon tanks	Very small	UEF = $0.3456 - (0.0020 * \text{Rated Storage Volume in Gallons})$
		Low	UEF = $0.5982 - (0.0019 * \text{Rated Storage Volume in Gallons})$
		Medium	UEF = $0.6483 - (0.0017 * \text{Rated Storage Volume in Gallons})$
		High	UEF = $0.6920 - (0.0013 * \text{Rated Storage Volume in Gallons})$

<sup>375</sup> All Residential sized Federal Standards are from DOE Standard 10 CFR 430, Residential-Duty and Commercial Federal Standard are from DOE Standard 10 CFR 431.

Equipment Type	Sub Category	Draw Pattern	Federal Standard – Uniform Energy Factor <sup>375</sup>
	>55 gallon and ≤100 gallon tanks	Very small	UEF = 0.6470 – (0.0006 * Rated Storage Volume in Gallons)
		Low	UEF = 0.7689 – (0.0005 * Rated Storage Volume in Gallons)
		Medium	UEF = 0.7897 – (0.0004 * Rated Storage Volume in Gallons)
		High	UEF = 0.8072 – (0.0003 * Rated Storage Volume in Gallons)
<u>Residential-duty Commercial</u> High Capacity Storage Gas-Fired Storage Water Heaters > 75,000 Btu/h	≤120 gallon tanks	Very small	UEF = 0.2674 – (0.0009 * Rated Storage Volume in Gallons)
		Low	UEF = 0.5362 – (0.0012 * Rated Storage Volume in Gallons)
		Medium	UEF = 0.6002 – (0.0011 * Rated Storage Volume in Gallons)
		High	UEF = 0.6597 – (0.0009 * Rated Storage Volume in Gallons)
<u>Commercial</u> Gas Storage Water Heaters >75,000 Btu/h and ≤155,000 Btu/h	>120 gallon tanks	All	80% E <sub>thermal</sub> , Standby Losses = (Q/800 + 110VRated Storage Volume in Gallons)
<u>Commercial</u> Gas Storage Water Heaters >155,000 Btu/h			
Residential Gas Instantaneous Water Heaters ≤ 200,000 Btu/h	≤2 gal	Very low	UEF = 0.80
		All other	UEF = 0.81
<u>Commercial Gas</u> Instantaneous Water Heaters > 200,000 Btu/h	<10 gal	All	80% E <sub>thermal</sub>
	≥10 gal	All	80% E <sub>thermal</sub>
Residential Electric Storage Water Heaters ≤ 75,000 Btu/h	≤55 gallon tanks	Very small	UEF = 0.8808 – (0.0008 * Rated Storage Volume in Gallons)
		Low	UEF = 0.9254 – (0.0003 * Rated Storage Volume in Gallons)
		Medium	UEF = 0.9307 – (0.0002 * Rated Storage Volume in Gallons)
		High	UEF = 0.9349 – (0.0001 * Rated Storage Volume in Gallons)
	>55 gallon and ≤120 gallon tanks <sup>376</sup>	Very small	UEF = 1.9236 – (0.0011 * Rated Storage Volume in Gallons)
		Low	UEF = 2.0440 – (0.0011 * Rated Storage Volume in Gallons)
		Medium	UEF = 2.1171 – (0.0011 * Rated Storage Volume in Gallons)
		High	UEF = 2.2418 – (0.0011 * Rated Storage Volume in Gallons)
Residential Electric Instantaneous Water Heaters	≤12kW and ≤2 gal	All other	UEF = 0.91
		High	UEF = 0.92
<u>Residential-duty Commercial</u> Electric Instantaneous Water Heaters	> 12kW and ≤58.6 kW and ≤2 gal	All	UEF = 0.80

Residential-duty Commercial Water Heaters meet the following criteria:

- Is not designed to provide outlet hot water at temperatures greater than 180 °F; and
- If electric, must use a single-phase external power supply; and
- Gas-fired Storage Water Heater with a rated input no greater than 105 kBtu/h and a DOE Rated Storage volume no greater than 120 gallons.
- Electric Instantaneous with a rated input no greater than 58.6 kW and a DOE Rated Storage volume no greater than 2 gallons.

Draw patterns are based on first hour rating (gallons) for storage tanks and maximum flow (GPM) for instantaneous as shown below:<sup>377</sup>

<sup>376</sup> It is assumed that tanks <75,000Btu/h and >55 gallons will not be eligible measures due to the high baseline.

<sup>377</sup> Definitions provided in 10 CFR 430, Subpart B, Appendix E, Section 5.4.1.

Storage Water Heater Draw Pattern	
Draw Pattern	First Hour Rating (gallons)
Very Small	≥ 0 and < 18
Low	≥ 18 and < 51
Medium	≥ 51 and < 75
High	≥ 75

Instantaneous Water Heater Draw Pattern	
Draw Pattern	Max GPM
Very Small	≥ 0 and < 1.7
Low	≥ 1.7 and < 2.8
Medium	≥ 2.8 and < 4
High	≥ 4

**DEEMED LIFETIME OF EFFICIENT EQUIPMENT**

The expected measure life is assumed to be 15 years for storage<sup>378</sup> and heat pump units<sup>379</sup>, 5 years for electric tankless,<sup>380</sup> and 20 years for gas tankless.<sup>381</sup>

**DEEMED MEASURE COST**

The full install cost and incremental cost assumptions are provided below. Actual costs should be used where available:

Gas storage water heaters:<sup>382</sup>

Equipment Type	Category	Install Cost	Incremental Cost
Gas Storage Water Heaters ≤ 75,000 Btu/h, ≤55 Gallons	Baseline	\$616	N/A
	Efficient	\$1,055	\$440
Gas Storage Water Heaters > 75,000 Btu/h	0.80 Et	\$4,886	N/A
	0.83 Et	\$5,106	\$220
	0.84 Et	\$5,299	\$413
	0.85 Et	\$5,415	\$529
	0.86 Et	\$5,532	\$646
	0.87 Et	\$5,648	\$762
	0.88 Et	\$5,765	\$879
	0.89 Et	\$5,882	\$996
	0.90 Et	\$6,021	\$1,135

For electric water heaters, the incremental capital cost for this measure is assumed to be:<sup>383</sup>

<sup>378</sup> DEER 08, EUL\_Summary\_10-1-08.xls.

<sup>379</sup> As recommended in Navigant ‘ComEd Effective Useful Life Research Report’, May 2018.

<sup>380</sup> Ohio Technical Reference Manual 8/2/2010 referencing CenterPoint Energy-Triennial CIP/DSM Plan 2010-2012 Report; Additional reference stating >20 years is sourced from the US DOE Energy Savers for Tankless or Demand-Type Water Heaters.

<sup>381</sup> Ibid.

<sup>382</sup> Cost information is based upon data from “2010-2012 WA017 Ex Ante Measure Cost Study Draft Report”, Itron, February 28, 2014. See “NR HW Heater\_WA017\_MCS Results Matrix - Volume I.xls” for more information.

<sup>383</sup> Act on Energy Commercial Technical Reference Manual, Table 9.6.1-4

Tank Size	Incremental Cost
50 gallons	\$1050
80 gallons	\$1050
100 gallons	\$1950

The incremental capital cost for an electric tankless heater this measure is assumed to be:<sup>384</sup>

Output (gpm) at delta T 70	Incremental Cost
5	\$1050
10	\$1050
15	\$1950

The incremental capital cost for a gas fired tankless heater is assumed to be<sup>385</sup>:

Output (gpm) at delta T 70	Incremental Cost
5.0	\$1,500
10.0	\$1,500
15.0	\$2,400

For a heat pump water heater, the incremental installation cost (including labor) should be used. Defaults are provided below.<sup>386</sup> Actual efficient costs can also be used although care should be taken as installation costs can vary For a heat pump water heater, the incremental installation cost (including labor) should be used. Defaults are provided below.<sup>387</sup> Actual efficient costs can also be used although care should be taken as installation costs can vary significantly due to complexities of a particular site.

Capacity	Efficiency Range	Baseline Installed Cost	Efficient Installed Cost	Incremental Installed Cost
≤55 gallons	<2.6 UEF	\$1,032	\$2,062	\$1,030
	≥2.6 UEF	\$1,032	\$2,231	\$1,199
>55 gallons	<2.6 UEF	\$1,319	\$2,432	\$1,113
	≥2.6 UEF	\$1,319	\$3,116	\$1,797

**LOADSHAPE**

For electric hot water heaters, use Loadshape C02 - Commercial Electric DHW.

<sup>384</sup> Act on Energy Technical Reference Manual, Table 9.6.2-3

<sup>385</sup> Act on Energy Commercial Technical Reference Manual, Table 9.6.3-4. Please see file ‘Ameren C and I TRM.pdf’ for further details.

<sup>386</sup> Costs for <2.6 UEF are based upon averages from the NEEP Phase 3 Incremental Cost Study. The assumption for higher efficiency tanks is based upon averaged from NEEP Phase 4 Incremental Cost Study. See ‘HPWH Cost Estimation.xls’ for more information.

<sup>387</sup> Costs for <2.6 UEF are based upon averages from the NEEP Phase 3 Incremental Cost Study. The assumption for higher efficiency tanks is based upon averaged from NEEP Phase 4 Incremental Cost Study. See ‘HPWH Cost Estimation.xls’ for more information.

**COINCIDENCE FACTOR**

The coincidence factor is assumed to be 0.925.<sup>388</sup>

---

**Algorithm**

---

**CALCULATION OF SAVINGS**

**ELECTRIC ENERGY AND FOSSIL FUEL SAVINGS**

Non Fuel Switch Measures

Electric energy savings are calculated for electric water heaters per the equations given below.

Electric units ≤12 kW:

$$\Delta kWh = \frac{(T_{out} - T_{in}) * HotWaterUse_{Gallon} * \gamma_{Water} * 1 * \left( \frac{1}{UEF_{elecbase}} - \frac{1}{UEF_{Eff}} \right)}{3412} + HPWHWasteHeat_{cool} - HPWHWasteHeat_{heat}$$

Electric units > 12kW:

$$\Delta kWh = \frac{\left( (T_{out} - T_{air}) * V * \gamma_{Water} * 1 * \left( \frac{SL_{elecbase} - SL_{eff}}{100} \right) \right) * 8766}{3412}$$

Natural gas energy savings are calculated for natural gas storage water heaters per the equations given below.

$$\Delta Therms = \frac{(T_{out} - T_{in}) * HotWaterUse_{Gallon} * \gamma_{Water} * 1 * \left( \frac{1}{UEF_{gasbase}} - \frac{1}{UEF_{Eff}} \right)}{100,000} - HPWHWasteHeat_{GasHeat}$$

**Additional Standby Loss Savings**

Gas Storage Water Heaters >75,000 Btu/h can claim additional savings due to lower standby losses.

$$\Delta Therms_{Standby} = \frac{(SL_{gasbase} - SL_{eff}) * 8766}{100,000}$$

**Fuel Switch/Electrification Measures:**

Fuel switch / electrification measures must produce positive total energy savings (i.e., reduction in Btus at the premises) in order to qualify. This is determined as follows:

Electric units ≤12 kW:

$$SiteEnergySavings \text{ (MMBTUs)} = [GasConsumptionReplaced] - [ElectricConsumptionAdded]$$

---

<sup>388</sup> Coincidence factor based on Average W in peak period/Max W from Itron eShape data for Missouri, calibrated to Illinois loads.



$$= \left[ \frac{(T_{out} - T_{in}) * HotWaterUse_{Gallon} * \gamma_{Water} * 1 * \left( \frac{1}{UEF_{gasbase}} \right)}{1,000,000} \right] - \left[ \frac{(T_{out} - T_{in}) * HotWaterUse_{Gallon} * \gamma_{Water} * 1 * \left( \frac{1}{UEF_{Eff}} \right)}{1,000,000} \right] + HPWHWasteHeat_{cool} - HPWHWasteHeat_{heat}$$

Electric units > 12kW and gas units >75,000 Btu/h:

$$SiteEnergySavings \text{ (MMBTUs)} = [GasConsumptionReplaced] - [ElectricConsumptionAdded]$$

$$= \left[ \frac{(T_{out} - T_{in}) * HotWaterUse_{Gallon} * \gamma_{Water} * 1 * \left( \frac{1}{UEF_{gasbase}} \right)}{1,000,000} + \frac{(SL_{gasbase} * 8766)}{1,000,000} \right] - \left[ \frac{\left( (T_{out} - T_{air}) * V * \gamma_{Water} * 1 * \left( \frac{SL_{elecbase} - SL_{eff}}{100} \right) \right) * 8766}{1,000,000} \right]$$

If SiteEnergySavings calculated above is positive, the measure is eligible.

The appropriate savings claim is dependent on which utilities are supporting the measure as provided in a table below:

Measure supported by:	Electric Utility claims (kWh):	Gas Utility claims (therms):
Electric utility only	SiteEnergySavings * 1,000,000/3,412	N/A
Electric and gas utility (Note utilities may make alternative agreements to how savings are allocated as long as total MMBtu savings remains the same).	%IncentiveElectric * SiteEnergySavings * 1,000,000/3,412	%IncentiveGas * SiteEnergySavings * 10
Gas utility only	N/A	SiteEnergySavings * 10

Where:

T<sub>OUT</sub> = Tank temperature  
= 125°F

T<sub>IN</sub> = Incoming water temperature from well or municipal system  
= 50.7°F<sup>389</sup>

HotWaterUse<sub>Gallon</sub> = Estimated annual hot water consumption (gallons)  
= Actual if possible to provide reasonable custom estimate. If not, two methodologies are provided to develop an estimate:

<sup>389</sup> Table 4 in Chen, et. al., "Calculating Average Hot Water Mixes of Residential Plumbing Fixtures", June 2020, reports a value of 50.7°F for inlet water temperature for U.S. Census Division 3.

1. Consumption per usable storage tank capacity

$$= \text{Capacity} * \text{Consumption/cap}$$

Where:

Capacity = Usable capacity of hot water storage tank in gallons  
 = Actual

Consumption/cap = Estimate of consumption per gallon of usable tank capacity, based on building type:<sup>390</sup>

Building Type <sup>391</sup>	Consumption/Cap
Convenience	528
Education	568
Grocery	528
Health	788
Large Office	511
Large Retail	528
Lodging	715
Other Commercial	341
Restaurant	622
Small Office	511
Small Retail	528
Warehouse	341
Nursing	672
Multi-Family	894
Unknown	555 <sup>392</sup>

2. Consumption per unit area by building type

$$= (\text{Area}/1000) * \text{Consumption}/1,000 \text{ sq.ft.}$$

Where:

Area = Area in sq.ft that is served by DHW boiler  
 = Actual

Consumption/1,000 sq.ft. = Estimate of DHW consumption per 1,000 sq.ft. based on building type:<sup>393</sup>

<sup>390</sup> Methodology based on Cadmus analysis. Annual hot water usage in gallons based on CBECS (2012) and RECS (2009) consumption data of East North Central (removed outliers of 1,000 kBtu/h or less) to calculate hot water usage. Annual hot water gallons per tank size gallons based on the tank sizing methodology found in ASHRAE 2011 HVAC Applications. Chapter 50 Service Water Heating. Demand assumptions (gallons per day) for each building type based on ASHRAE Chapter 50 and to LBNL White Paper. LBL-37398 Technology Data Characterizing Water Heating in Commercial Buildings: Application to End Use Forecasting. Assumes hot water heater efficiency of 80%.

<sup>391</sup> According to CBECS 2012 “Lodging” buildings include Dormitories, Hotels, Motel or Inns and other Lodging and “Nursing” buildings include Assisted Living and Nursing Homes.

<sup>392</sup> From a historical average of all Ameren Illinois commercial & industrial water heater applications from 2013-2022

<sup>393</sup> Methodology based on Cadmus analysis. Annual hot water usage in gallons based on CBECS (2012) and RECS (2009) consumption data of East North Central (removed outliers of 1,000 kBtu/h or less) to calculate hot water usage. Annual hot water gallons per tank size gallons based on the tank sizing methodology found in ASHRAE 2011 HVAC Applications. Chapter 50 Service Water Heating. Demand assumptions (gallons per day) for each building type based on ASHRAE Chapter 50 and to LBNL White Paper. LBL-37398 Technology Data Characterizing Water Heating in Commercial Buildings: Application to End Use Forecasting. Assumes hot water heater efficiency of 80%.

Building Type <sup>394</sup>	Consumption/1,000 sq.ft.
Convenience	4,594
Education	7,285
Grocery	697
Health	24,540
Large Office	1,818
Large Retail	1,354
Lodging	29,548
Other Commercial	3,941
Restaurant	44,439
Small Office	1,540
Small Retail	6,111
Warehouse	1,239
Nursing	30,503
Multi-Family	15,434

$\gamma_{\text{Water}}$  = Specific weight capacity of water (lb/gal)  
 = 8.33 lbs/gal

$c_p$  = Specific heat of water (Btu/lb.°F)

$UEF_{\text{elecbase}}$  = Rated efficiency of baseline water heater expressed as Uniform Energy Factor (UEF);

Note the same draw pattern (very small, low, medium and high draw) should be used for both baseline and efficient units.

Equipment Type	Sub Category	Draw Pattern	Federal Standard – Uniform Energy Factor <sup>395</sup>
Residential Electric Storage Water Heaters ≤ 75,000 Btu/h	≤55 gallon tanks	Very small	UEF = 0.8808 – (0.0008 * Rated Storage Volume in Gallons)
		Low	UEF = 0.9254 – (0.0003 * Rated Storage Volume in Gallons)
		Medium	UEF = 0.9307 – (0.0002 * Rated Storage Volume in Gallons)
		High	UEF = 0.9349 – (0.0001 * Rated Storage Volume in Gallons)
	>55 gallon and ≤120 gallon tanks <sup>396</sup>	Very small	UEF = 1.9236 – (0.0011 * Rated Storage Volume in Gallons)
		Low	UEF = 2.0440 – (0.0011 * Rated Storage Volume in Gallons)
		Medium	UEF = 2.1171 – (0.0011 * Rated Storage Volume in Gallons)
		High	UEF = 2.2418 – (0.0011 * Rated Storage Volume in Gallons)
Residential Electric Instantaneous Water Heaters	≤12kW and ≤2 gal	All other	UEF = 0.91
		High	UEF = 0.92
<u>Residential-duty Commercial Electric Instantaneous Water Heaters</u>	> 12kW and ≤58.6 kW and ≤2 gal	All	UEF = 0.80

Draw patterns are based on first hour rating (gallons) for storage tanks and maximum flow (GPM) for instantaneous as shown below:<sup>397</sup>

<sup>394</sup> According to CBECS 2012 “Lodging” buildings include Dormitories, Hotels, Motel or Inns and other Lodging and “Nursing” buildings include Assisted Living and Nursing Homes.

<sup>395</sup> All Residential sized Federal Standards are from DOE Standard 10 CFR 430, Residential-Duty and Commercial Federal Standard are from DOE Standard 10 CFR 431.

<sup>396</sup> It is assumed that tanks <75,000Btu/h and >55 gallons will not be eligible measures due to the high baseline.

<sup>397</sup> Definitions provided in 10 CFR 430, Subpart B, Appendix E, Section 5.4.1.

Storage Water Heater Draw Pattern	
Draw Pattern	First Hour Rating (gallons)
Very Small	≥ 0 and < 18
Low	≥ 18 and < 51
Medium	≥ 51 and < 75
High	≥ 75

Instantaneous Water Heater Draw Pattern	
Draw Pattern	Max GPM
Very Small	≥ 0 and < 1.7
Low	≥ 1.7 and < 2.8
Medium	≥ 2.8 and < 4
High	≥ 4

UEF<sub>eff</sub> = Rated efficiency of efficient water heater expressed as Uniform Energy Factor (UEF)  
 = Actual

3412 = Converts Btu to kWh

HPWHWasteheat<sub>cool</sub> = Heat Pump Water Heater Only - Cooling savings from conversion of heat in building to water heat<sup>398</sup>

$$= \left[ \frac{\left( (T_{OUT} - T_{IN}) * HotWaterUse_{Gallon} * \gamma_{Water} * 1 * \left( 1 - \frac{1}{UEF_{Eff}} \right) \right) * LF * 25\% * LM}{COP_{COOL} * 3412} \right] * Cool$$

Where:

- LF = Location Factor  
 = 1.0 for HPWH installation in a conditioned space  
 = 0.5 for HPWH installation in an unknown location<sup>399</sup>  
 = 0.0 for installation in an unconditioned space
- 25% = Portion of reduced waste heat that results in cooling savings<sup>400</sup>
- COP<sub>COOL</sub> = COP of Central Air Conditioner  
 = Actual - If unknown, assume 3.08 (10.5 SEER / 3.412)
- LM = Latent multiplier to account for latent cooling demand

<sup>398</sup> This algorithm calculates the heat removed from the air by subtracting the HPWH electric consumption from the total water heating energy delivered. This is then adjusted to account for location of the HP unit and the coincidence of the waste heat with cooling requirements, the efficiency of the central cooling, and latent cooling demands.

<sup>399</sup> Note unconditioned means a space that is not intentionally heated via furnace vents or boiler radiators. The presence of and/or leakage from a heating system in a space doesn't in itself imply the space is conditioned.

<sup>400</sup> This is estimated based on the percentage of lighting savings that result in reduced cooling loads (lighting is used as a proxy for hot water heating since load shapes suggest their seasonal usage patterns are similar). This is based on the WHFe for unknown non-residential buildings (1.08) and assuming an average cooling COP of 3.08 (1.08 = 1 + 0.246/3.08).

$$= 1.33^{401}$$

Cool = 1 if building has central cooling, 0 if not cooled

HPWHWasteheat<sub>Heat</sub> = Heat Pump Water Heater Only - Heating cost from conversion of heat in building to water heat (dependent on heating fuel)

$$= \left( \frac{\left( (T_{OUT} - T_{IN}) * HotWaterUse_{Gallon} * \gamma_{Water} * 1 * \left( 1 - \frac{1}{UEF_{Eff}} \right) \right) * LF * 35\%}{COP_{HEAT} * 3412} \right) * ElectricHeat$$

Where:

35% = Portion of reduced waste heat that results in increased heating load<sup>402</sup>

COP<sub>HEAT</sub> = COP of electric heating system

= Actual system efficiency including duct loss - If not available, use:<sup>403</sup>

System Type	Age of Equipment	HSPF Estimate	ηHeat (Effective COP Estimate) (HSPF/3.412)*0.85
Heat Pump	Before 2006	6.8	1.7
	2006 - 2014	7.7	1.92
	2015 on	8.2	2.04
Resistance	N/A	N/A	1

ElectricHeat = 1 if building is electrically heated, 0 if not

**For example**, for a 50 gallon, 95% UEF storage unit installed in a 1500 ft<sup>2</sup> restaurant:

$$\Delta kWh = ((125 - 50.7) * ((1,500/1,000) * 44,439) * 8.33 * 1 * (1/0.88 - 1/0.95))/3412 + 0 + 0$$

$$= 1012 kWh$$

Electric units > 12kW:

T<sub>air</sub> = Ambient Air Temperature  
= 70°F

<sup>401</sup> A sensible heat ratio (SHR) of 0.75 corresponds to a latent multiplier of 4/3 or 1.33. SHR of 0.75 for typical split system from page 10 of "Controlling Indoor Humidity Using Variable-Speed Compressors and Blowers" by M. A. Andrade and C. W. Bullard, 1999: [www.ideals.illinois.edu/bitstream/handle/2142/11894/TR151.pdf](http://www.ideals.illinois.edu/bitstream/handle/2142/11894/TR151.pdf)

<sup>402</sup> This is estimated based on the percentage of lighting savings that result in increased heating loads (lighting is used as a proxy for hot water heating since load shapes suggest their seasonal usage patterns are similar). The WHFh for unknown non-residential buildings is 35%.

<sup>403</sup> These default system efficiencies are based on the applicable minimum Federal Standards. In 2006 the Federal Standard for Heat Pumps was adjusted. While one would expect the average system efficiency to be higher than this minimum, the likely degradation of efficiencies over time means that using the minimum standard is appropriate. An 85% distribution efficiency is then applied to account for duct losses for heat pumps.

- V = Rated tank volume in gallons
- = Actual
- SL<sub>elecbase</sub> = Standby loss of electric baseline unit (%/hr)
- = 0.30 + 27/V
- SL<sub>eff</sub> = Nameplate standby loss of new water heater, in BTU/h
- 8766 = Hours per year

**For example**, >12kW, 100 gallon storage unit with rated standby loss of 0.5 %/hr:

SL<sub>base</sub> = 0.3 + (27 / 100)  
 = 0.57%/hr

ΔkWh = (((125 – 70) \* 100 \* 8.33 \* 1 \* (0.57- 0.5)/100) \* 8766)/3412  
 = 82.4 kWh

Gas units:

- 100,000 = Converts Btu to Therms
- EF<sub>gasbase</sub> = Rated efficiency of baseline water heater (expressed as Uniform Energy Factor (UEF) or Thermal Efficiency as provided below).

Note the same draw pattern (very small, low, medium and high draw) should be used for both baseline and efficient units.

Equipment Type	Sub Category	Draw Pattern	Federal Standard – Uniform Energy Factor <sup>404</sup>
Residential Gas Storage Water Heaters ≤75,000 Btu/h	≤55 gallon tanks	Very small	UEF = 0.3456 – (0.0020 * Rated Storage Volume in Gallons)
		Low	UEF = 0.5982 – (0.0019 * Rated Storage Volume in Gallons)
		Medium	UEF = 0.6483 – (0.0017 * Rated Storage Volume in Gallons)
		High	UEF = 0.6920 – (0.0013 * Rated Storage Volume in Gallons)
	>55 gallon and ≤100 gallon tanks	Very small	UEF = 0.6470 – (0.0006 * Rated Storage Volume in Gallons)
		Low	UEF = 0.7689 – (0.0005 * Rated Storage Volume in Gallons)
		Medium	UEF = 0.7897 – (0.0004 * Rated Storage Volume in Gallons)
		High	UEF = 0.8072 – (0.0003 * Rated Storage Volume in Gallons)
Residential-duty Commercial High Capacity Storage Gas-Fired Storage Water Heaters > 75,000 Btu/h	≤120 gallon tanks	Very small	UEF = 0.2674 – (0.0009 * Rated Storage Volume in Gallons)
		Low	UEF = 0.5362 – (0.0012 * Rated Storage Volume in Gallons)
		Medium	UEF = 0.6002 – (0.0011 * Rated Storage Volume in Gallons)
		High	UEF = 0.6597 – (0.0009 * Rated Storage Volume in Gallons)
Commercial Gas Storage Water Heaters >75,000 Btu/h and ≤155,000 Btu/h	>120 gallon tanks	All	80% E <sub>thermal</sub> , Standby Losses = (Q / 800 + 110V Rated Storage Volume in Gallons)
Commercial Gas Storage Water Heaters >155,000 Btu/h			
Residential Gas Instantaneous Water Heaters ≤ 200,000 Btu/h	≤2 gal	Very low	UEF = 0.80
		All other	UEF = 0.81
	<10 gal	All	80% E <sub>thermal</sub>

<sup>404</sup> All Residential sized Federal Standards are from DOE Standard 10 CFR 430, Residential-Duty and Commercial Federal Standard are from DOE Standard 10 CFR 431.

Equipment Type	Sub Category	Draw Pattern	Federal Standard – Uniform Energy Factor <sup>404</sup>
Commercial Gas Instantaneous Water Heaters > 200,000 Btu/h	≥10 gal	All	78% E <sub>thermal</sub>

Draw patterns are based on first hour rating (gallons) for storage tanks and maximum flow (GPM) for instantaneous as shown below:<sup>405</sup>

Storage Water Heater Draw Pattern	
Draw Pattern	First Hour Rating (gallons)
Very Small	≥ 0 and < 18
Low	≥ 18 and < 51
Medium	≥ 51 and < 75
High	≥ 75

Instantaneous Water Heater Draw Pattern	
Draw Pattern	Max GPM
Very Small	≥ 0 and < 1.7
Low	≥ 1.7 and < 2.8
Medium	≥ 2.8 and < 4

HPWHWasteHeat<sub>GasHeat</sub> = Heat Pump Water Heater Only - Heating cost from conversion of heat in building to water heat (dependent on heating fuel)

$$= \left( \frac{\left( (T_{OUT} - T_{IN}) * HotWaterUse_{Gallon} * \gamma_{Water} * 1 * \left( 1 - \frac{1}{UEF_{Eff}} \right) \right) * LF * 35\%}{100,000 * \eta_{Heat}} \right) * (1 - ElectricHeat)$$

$\eta_{Heat}$  = Heating system efficiency including duct loss  
= Actual

Where:

- SL<sub>gasbase</sub> = Standby loss of gas baseline unit (Btu/h)  
=  $Q/800 + 110\sqrt{V}$
- Q = Nameplate input rating in Btu/h
- V = Rated volume in gallons
- SL<sub>eff</sub> = Nameplate standby loss of new water heater, in Btu/h
- 8766 = Hours per year

<sup>405</sup> Definitions provided in 10 CFR 430, Subpart B, Appendix E, Section 5.4.1.

**For example**, for a 200,000 Btu/h, 150 gallon, 90% UEF storage unit with rated standby loss of 1029 BTU/h installed in a 1500 ft<sup>2</sup> restaurant:

$$\begin{aligned} \Delta\text{Therms} &= ((125 - 50.7) * ((1,500/1,000) * 44,439) * 8.33 * 1 * (1/0.8 - 1/0.9))/100,000 \\ &= 57.3 \text{ Therms} \\ \Delta\text{Therms}_{\text{Standby}} &= (((200000/800 + 110 * \sqrt{150}) - 1029) * 8766)/100,000 \\ &= 49.8 \text{ Therms} \\ \Delta\text{Therms}_{\text{Total}} &= 57.3 + 49.8 \\ &= 107.1 \text{ Therms} \end{aligned}$$

### SUMMER COINCIDENT PEAK DEMAND SAVINGS

$$\Delta kW = \frac{\Delta kWh}{\text{Hours}} * CF$$

Where:

$$\begin{aligned} \text{Hours} &= \text{Full load hours of water heater} \\ &= 6461^{406} \\ CF &= \text{Summer Peak Coincidence Factor for measure} \\ &= 0.925^{407} \end{aligned}$$

**For example**, >12kW, 100 gallon storage unit with rated standby loss of 0.5 %/hr:

$$\begin{aligned} \Delta kW &= 82.4 / 6,461 * 0.925 \\ &= 0.0118 \text{ kW} \end{aligned}$$

### FOSSIL FUEL SAVINGS

Calculation provided together with Electric Energy Savings above.

### DEEMED O&M COST ADJUSTMENT CALCULATION

The deemed O&M cost adjustment for a tankless heaters is \$100.<sup>408</sup>

### COST EFFECTIVENESS SCREENING AND LOAD REDUCTION FORECASTING WHEN FUEL SWITCHING

This measure can involve fuel switching from fossil fuel to electric.

<sup>406</sup> Full load hours assumption based on Wh/Max W Ratio from Itron eShape data for Missouri, calibrated to Illinois loads.

<sup>407</sup> Coincidence factor based on Average W in peak period/Max W from Itron eShape data for Missouri, calibrated to Illinois loads.

<sup>408</sup> Water heaters (WH) require annual maintenance. There are different levels of effort for annual maintenance depending if the unit is gas or electric, tanked or tankless. Electric and gas tank water heater manufacturers recommend an annual tank drain to clear sediments. Also recommended are “periodic” inspections by qualified service professionals of operating controls, heating element and wiring for electric WHs and thermostat, burner, relief valve internal flue-way and venting systems for gas WHs. Tankless WH require annual maintenance by licensed professionals to clean control compartments, burners, venting system and heat exchangers. This information is from WH manufacturer product brochures including GE, Rinnai, Rheem, Takagi and Kenmore. References for incremental O&M costs were not found. Therefore the incremental cost of the additional annual maintenance for tankless WH is estimated at \$100.



For the purposes of forecasting load reductions due to fuel switch projects per Section 16-111.5B, changes in site energy use at the customer’s meter (using ΔkWh algorithm below), customer switching estimates, NTG, and any other adjustment factors deemed appropriate, should be used.

The inputs to cost effectiveness screening should reflect the actual impacts on the electric and fuel consumption at the customer meter and, for fuel switching measures, should therefore reflect the decrease in one fuel and increase in another, as opposed to the single savings value calculated in the “Electric and Fossil Fuel Energy Savings” section above. Therefore in addition to the calculation of savings claimed, the following values should be used to assess the cost effectiveness of the measure.

Electric units ≤12 kW:

$$\begin{aligned} \Delta\text{Therms} &= [\text{GasConsumptionReplaced}] \\ &= \left[ \frac{(T_{out} - T_{in}) * \text{HotWaterUse}_{\text{Gallon}} * \gamma\text{Water} * 1 * \left(\frac{1}{UEF_{\text{gasbase}}}\right)}{100,000} \right] \\ \Delta\text{kWh} &= [\text{ElectricConsumptionAdded}] \\ &= - \left[ \frac{(T_{out} - T_{in}) * \text{HotWaterUse}_{\text{Gallon}} * \gamma\text{Water} * 1 * \left(\frac{1}{UEF_{\text{Eff}}}\right)}{3,412} + \text{HPWHWasteHeat}_{\text{cool}} \right. \\ &\quad \left. - \text{HPWHWasteHeat}_{\text{heat}} \right] \end{aligned}$$

Electric units > 12kW and gas units >75,000 Btu/h:

$$\begin{aligned} \Delta\text{Therms} &= [\text{GasConsumptionReplaced}] \\ &= \left[ \frac{(T_{out} - T_{in}) * \text{HotWaterUse}_{\text{Gallon}} * \gamma\text{Water} * 1 * \left(\frac{1}{UEF_{\text{gasbase}}}\right)}{100,000} + \frac{(SL_{\text{gasbase}} * 8766)}{100,000} \right] \\ \Delta\text{kWh} &= [\text{ElectricConsumptionAdded}] \\ &= - \left[ \frac{\left( (T_{out} - T_{air}) * V * \gamma\text{Water} * 1 * \left(\frac{SL_{\text{elecbase}} - SL_{\text{eff}}}{100}\right) \right) * 8766}{1,000,000} \right] \end{aligned}$$

**MEASURE CODE: CI-HWE-STWH-V10-240101**

**REVIEW DEADLINE: 1/1/2027**

## 4.3.2 Low Flow Faucet Aerators

### DESCRIPTION

This measure relates to the direct installation of a low flow faucet aerator in a commercial building. Expected applications include small business, office, restaurant, or motel. Health care-specific inputs are defined for Laminar Flow Restrictor (LFR) devices. For multifamily or senior housing, the residential low flow faucet aerator should be used.

This measure was developed to be applicable to the following program types, DI, KITS. If applied to other program types, the measure savings should be verified.

### DEFINITION OF EFFICIENT EQUIPMENT

To qualify for this measure the installed equipment must be an energy efficient faucet aerator, for bathrooms rated at 1.5 gallons per minute (GPM) or less, or for kitchens rated at 2.2 GPM or less. For LFR devices, the installed equipment must be a device rated at 2.2 GPM or less. Savings are calculated on an average savings per faucet fixture basis.

### DEFINITION OF BASELINE EQUIPMENT

The baseline condition is assumed to be a standard bathroom or kitchen faucet aerator. For LFR devices, the baseline condition is assumed to be no aerator at all, due to the contamination risk caused by faucet aerators in health care facilities and the baseline flow rate is assumed to be 3.74 GPM<sup>409</sup>. Note if flow rates are measured, for example through a Direct Install program, then actual baseline flow rates should be used as opposed to the deemed values.

### DEEMED LIFETIME OF EFFICIENT EQUIPMENT

The expected measure life is assumed to be 10 years.<sup>410</sup>

### DEEMED MEASURE COST

The actual full install cost (including labor) for this measure should be used. If unknown assume \$8 for faucet aerators<sup>411</sup> and \$14.27 for LFR devices.<sup>412</sup>

### LOADSHAPE

Loadshape C02 - Commercial Electric DHW

### COINCIDENCE FACTOR

The coincidence factor for this measure is dependent on building type as presented below.

---

<sup>409</sup> Workpaper WPSCGNRWH150827A, Laminar Flow Restrictors For Hospitals and Health Care Facilities.

<sup>410</sup> As recommended in Navigant 'ComEd Effective Useful Life Research Report', May 2018.

<sup>411</sup> Direct-install price per faucet assumes cost of aerator and install time. (2011, Market research average of \$3 and assess and install time of \$5 (20min @ \$15/hr).

<sup>412</sup> Direct install price per faucet assumes cost of LFR (\$7.27) and install time (\$7) (Southern California Gas Company, Workpaper WPSCGNRWH150827A Revision #0, September, 2015).

**Algorithm**

**CALCULATION OF SAVINGS**

**ELECTRIC ENERGY SAVINGS**

Note these savings are *per faucet retrofitted*.<sup>413</sup>

$$\Delta kWh = \%ElectricDHW * ((GPM\_base - GPM\_low)/GPM\_base) * Usage * EPG\_electric * ISR$$

Where:

**%ElectricDHW** = proportion of water heating supplied by electric resistance heating

DHW fuel	%Electric_DHW
Electric	100%
Fossil Fuel	0%
Unknown	27.6% <sup>414</sup>

**GPM\_base** = Average flow rate, in gallons per minute, of the baseline faucet “as-used”  
 = 1.39,<sup>415</sup> or custom based on metering studies,<sup>416</sup> or, if measured during DI:  
 = Measured full throttle flow \* 0.83 throttling factor<sup>417</sup>  
 Baseline for LFRs<sup>418</sup> = 3.74 \* 0.83 = 3.10

**GPM\_low** = Average flow rate, in gallons per minute, of the low-flow faucet aerator “as-used”  
 = 0.94,<sup>419</sup> or custom based on metering studies,<sup>420</sup> or, if measured during DI:  
 = Rated full throttle flow \* 0.95 throttling factor<sup>421</sup>

<sup>413</sup> This algorithm calculates the amount of energy saved per aerator by determining the fraction of water consumption savings for the upgraded fixture. Due to the distribution of water consumption by fixture type, as well as the different number of fixtures in a building, several variables must be incorporated.

<sup>414</sup> Based on Applied Energy Group, 2016 'Ameren Illinois Demand Side Management Market Potential Study: Volume 4 – APPENDICES'.

<sup>415</sup> DeOreo, B., and P. Mayer. Residential End Uses of Water Study Update. Forthcoming. ©2015 Water Research Foundation. Reprinted With Permission.

<sup>416</sup> Measurement should be based on actual average flow consumed over a period of time rather than a onetime spot measurement for maximum flow. Studies have shown maximum flow rates do not correspond well to average flow rate due to occupant behavior which does not always use maximum flow.

<sup>417</sup> 2008, Schultdt, Marc, and Debra Tachibana. Energy related Water Fixture Measurements: Securing the Baseline for Northwest Single Family Homes. 2008 ACEEE Summer Study on Energy Efficiency in Buildings. Page 1-265.

<sup>418</sup> Using measured flow rate assumption from Workpaper WPCGNRWH150827A, Laminar Flow Restrictors For Hospitals and Health Care Facilities.

<sup>419</sup> Average retrofit flow rate for kitchen and bathroom faucet aerators from sources 2, 4, 5, and 7. This accounts for all throttling and differences from rated flow rates. Assumes all kitchen aerators at 2.2 gpm or less and all bathroom aerators at 1.5 gpm or less. The most comprehensive available studies did not disaggregate kitchen use from bathroom use, but instead looked at total flow and length of use for all faucets. This makes it difficult to reliably separate kitchen water use from bathroom water use. It is possible that programs installing low flow aerators lower than the 2.2 gpm for kitchens and 1.5 gpm for bathrooms will see a lower overall average retrofit flow rate.

<sup>420</sup> Measurement should be based on actual average flow consumed over a period of time rather than a onetime spot measurement for maximum flow. Studies have shown maximum flow rates do not correspond well to average flow rate due to occupant behavior which does not always use maximum flow.

<sup>421</sup> 2008, Schultdt, Marc, and Debra Tachibana. Energy related Water Fixture Measurements: Securing the Baseline for Northwest Single Family Homes. 2008 ACEEE Summer Study on Energy Efficiency in Buildings. Page 1-265.

For LFRs<sup>422</sup> = 2.2 \* 0.95 = 2.09

Usage = Estimated usage of mixed water (mixture of hot water from water heater line and cold water line) per faucet (gallons per year)

= If data is available to provide a reasonable custom estimate it should be used; if not, use the following defaults (or substitute custom information in to the calculation):

Building Type	Gallons hot water per unit per day <sup>423</sup> (A)	Unit	Estimated % hot water from Faucets <sup>424</sup> (B)	Multiplier <sup>425</sup> (C)	Unit	Days per year (D)	Annual gallons mixed water per faucet (A*B*C*D)
Small Office	1	person	100%	10	employees per faucet	250	2,500
Large Office	1	person	100%	45	employees per faucet	250	11,250
Fast Food Rest	0.7	meal/day	50%	75	meals per faucet	365	9,581
Sit-Down Rest	2.4	meal/day	50%	36	meals per faucet	365	15,768
Retail	2	employee	100%	5	employees per faucet	365	3,650
Grocery	2	employee	100%	5	employees per faucet	365	3,650
Warehouse	2	employee	100%	5	employees per faucet	250	2,500
Elementary School	0.6	person	50%	50	students per faucet	200	3,000
Jr High/High School	1.8	person	50%	50	students per faucet	200	9,000
Health	90	patient	25%	2	Patients per faucet	365	16,425
Motel	20	room	25%	1	faucet per room	365	1,825
Hotel	14	room	25%	1	faucet per room	365	1,278
Other	1	employee	100%	20	employees per faucet	250	5,000

EPG<sub>electric</sub> = Energy per gallon of mixed water used by faucet (electric water heater)  
 = (8.33 \* 1.0 \* (WaterTemp - SupplyTemp)) / (RE<sub>electric</sub> \* 3412)  
 = 0.0879 kWh/gal for Bath, 0.1054 kWh/gal for Kitchen, 0.1477 kWh/gal for LFRs, 0.1004 kWh/gal for unknown

8.33 = Specific weight of water (lbs/gallon)

1.0 = Heat Capacity of water (btu/lb-°F)

WaterTemp = Assumed temperature of mixed water  
 = 86°F for Bath, 93°F for Kitchen, 91°F for Unknown,<sup>426</sup> 110°F for health care facilities<sup>427</sup>

SupplyTemp = Assumed temperature of water entering building

<sup>422</sup> Using measured flow rate assumption from Workpaper WPCSGNRWH150827A, Laminar Flow Restrictors For Hospitals and Health Care Facilities.

<sup>423</sup> Table 2-45 Chapter 49, Service Water Heating, 2007 ASHRAE Handbook, HVAC Applications.

<sup>424</sup> Estimated based on data provided in Appendix E; “Waste Not, Want Not: The Potential for Urban Water Conservation in California”, Pacific Institute, November 2003.

<sup>425</sup> Based on review of the Illinois plumbing code (Employees and students per faucet). Retail, grocery, warehouse and health are estimates. Meals per faucet estimated as 4 bathroom and 3 kitchen faucets and average meals per day of 250 (based on California study above) – 250/7 = 36. Fast food assumption estimated.

<sup>426</sup> Cadmus and Opinion Dynamics Showerhead and Faucet Aerator Meter Study Memorandum dated June 2013, directed to Michigan Evaluation Working Group. If the aerator location is unknown an average of 91% should be used which is based on the assumption that 70% of household water runs through the kitchen faucet and 30% through the bathroom (0.7\*93)+(0.3\*86)=0.91.

<sup>427</sup> Southern California Gas Company, Workpaper WPCSGNRWH150827A Revision #0, September, 2015.

- = 50.7°F <sup>428</sup>
- RE\_electric = Recovery efficiency of electric water heater  
= 98% <sup>429</sup>
- 3412 = Converts Btu to kWh (Btu/kWh)
- ISR = In service rate of faucet aerators dependant on install method as listed in table below:

Selection	ISR
Direct Install - Deemed <sup>430</sup>	0.95
Efficiency Kits - Default <sup>431</sup>	0.50
Leave-Behind Kit <sup>432</sup>	0.91

**For example**, a direct installed kitchen faucet in a large office with electric DHW:  

$$\Delta kWh = 1 * ((1.39 - 0.94)/1.39) * 11,250 * 0.1054 * 0.95$$

$$= 364.7 \text{ kWh}$$

**For example**, a direct installed bathroom faucet in an Elementary School with electric DHW:  

$$\Delta kWh = 1 * ((1.39 - 0.94)/1.39) * 3,000 * 0.0879 * 0.95$$

$$= 81.1 \text{ kWh}$$

Secondary kWh Savings for Water Supply and Wastewater Treatment

The following savings should be included in the total savings for this measure, but should not be included in TRC tests to avoid double counting the economic benefit of water savings.

$$\Delta kWh_{\text{water}} = \Delta \text{Water (gallons)} / 1,000,000 * E_{\text{water total}}$$

Where

$$E_{\text{water total}} = \text{IL Total Water Energy Factor (kWh/Million Gallons)}$$

$$= 5,010^{433}$$

<sup>428</sup> Table 4 in Chen, et. al., "Calculating Average Hot Water Mixes of Residential Plumbing Fixtures", June 2020, reports a value of 50.7°F for inlet water temperature for U.S. Census Division 3.

<sup>429</sup> Electric water heaters have recovery efficiency of 98%, as sourced from available products on the AHRI Certification Directory.

<sup>430</sup> ComEd Energy Efficiency/Demand Response Plan: Plan Year 2 (6/1/2009-5/31/2010) Evaluation Report: All Electric Single Family Home Energy Performance Tune-Up Program, December 21, 2010, Table 3-8.

<sup>431</sup> Analysis of CY2018, CY2019, and CY2020 Small Business Kit participant survey installation data. Use if annual survey data is not available or applicable. Please see file "SB Kits Survey Analysis TRMv10 Support.xlsx"

<sup>432</sup> Based on DCEO STEP Program GPY5 evaluation report for showerheads and aerators. Guidehouse, *In-Service Rates for a CY2020 Business Remote Assessment Path for Customer Installed Measures*, August 21, 2020. Please see file "Business Program Remote Assessment and Install ISR Memo 2020-08-21.docx"

<sup>433</sup> This factor include 2571 kWh/MG for water supply based on Illinois energy intensity data from a 2012 ISAWWA study and 2439 kWh/MG for wastewater treatment based on national energy intensity use estimates. For more information please review Elevate Energy's 'IL TRM: Energy per Gallon Factor, May 2018 paper'.

**For example**, a direct installed faucet in a large office:

$$\begin{aligned} \Delta\text{Water (gallons)} &= ((1.39 - 0.94)/1.39) * 11,250 * 0.95 \\ &= 3,640 \text{ gallons} \\ \Delta\text{kWh}_{\text{water}} &= 3,640/1,000,000*5,010 \\ &= 18 \text{ kWh} \end{aligned}$$

**SUMMER COINCIDENT PEAK DEMAND SAVINGS**

$$\Delta\text{kW} = (\Delta\text{kWh} / \text{Hours}) * \text{CF}$$

Where:

$\Delta\text{kWh}$  = calculated value above on a per faucet basis. Note do not include the secondary savings in this calculation.

Hours = Annual electric DHW recovery hours for faucet use

$$= (\text{Usage} * 0.44^{434}) / \text{GPH}$$

= Calculate if usage is custom, if using default usage use:

Building Type	Annual Recovery Hours
Small Office	20
Large Office	92
Fast Food Rest	78
Sit-Down Rest	129
Retail	30
Grocery	30
Warehouse	20
Elementary School	24
Jr High/High School	73
Health	134
Motel	15
Hotel	10
Other	41

Where:

GPH = Gallons per hour recovery of electric water heater calculated for 89.3F temp rise (140-50.7), 98% recovery efficiency, and typical 12kW electric resistance storage tank.

$$= 53.9$$

CF = Coincidence Factor for electric load reduction

= Dependent on building type<sup>435</sup>

<sup>434</sup> 44% is the proportion of hot 140°F water mixed with 50.7°F supply water to give 90°F mixed faucet water.

<sup>435</sup> Calculated as follows: Assumptions for percentage of usage during peak period (1-5pm) were made and then multiplied by 65/365 (65 being the number of days in peak period) and by the number of total annual recovery hours to give an estimate of the number of hours of recovery during peak periods. There are 260 hours in the peak period so the probability you will see savings during the peak period is calculated as the number of hours of recovery during peak divided by 260. See 'C&I Faucet Aerator.xls' for details.

Building Type	Coincidence Factor
Small Office	0.0064
Large Office	0.0288
Fast Food Rest	0.0084
Sit-Down Rest	0.0184
Retail	0.0043
Grocery	0.0043
Warehouse	0.0064
Elementary School	0.0096
Jr High/High School	0.0288
Health	0.0144
Motel	0.0006
Hotel	0.0004
Other	0.0128

**For example**, a direct installed kitchen faucet in a large office with electric DHW:  
 $\Delta kW = 364.7/92 * 0.0288$   
 $= 0.1142 \text{ kW}$

**For example**, a direct installed bathroom faucet in an Elementary School with electric DHW:  
 $\Delta kW = 81.1/24 * 0.0096$   
 $= 0.0324 \text{ kW}$

**FOSSIL FUEL IMPACT DESCRIPTIONS AND CALCULATION**

$$\Delta \text{Therms} = \% \text{FossilDHW} * ((\text{GPM}_{\text{base}} - \text{GPM}_{\text{low}}) / \text{GPM}_{\text{base}}) * \text{Usage} * \text{EPG}_{\text{gas}} * \text{ISR}$$

Where:

$\% \text{FossilDHW}$  = proportion of water heating supplied by fossil fuel heating

DHW fuel	$\% \text{Fossil}_{\text{DHW}}$
Electric	0%
Fossil Fuel	100%
Unknown	72.4% <sup>436</sup>

$\text{EPG}_{\text{gas}}$  = Energy per gallon of mixed water used by faucet (gas water heater)  
 $= (8.33 * 1.0 * (\text{WaterTemp} - \text{SupplyTemp})) / (\text{RE}_{\text{gas}} * 100,000)$   
 $= 0.0044 \text{ Therm/gal for Bath, } 0.0053 \text{ Therm/gal for Kitchen, } 0.0074 \text{ Therm/gal for LFRs, } 0.0050 \text{ Therm/gal for unknown}$

Where:

$\text{RE}_{\text{gas}}$  = Recovery efficiency of gas water heater

<sup>436</sup> Based on Applied Energy Group, 2016 'Ameren Illinois Demand Side Management Market Potential Study: Volume 4 – APPENDICES'.

$$= 67\%^{437}$$

$$100,000 = \text{Converts Btus to Therms (Btu/Therm)}$$

Other variables as defined above.

**For example**, a direct installed kitchen faucet in a large office with gas DHW:

$$\begin{aligned} \Delta\text{Therms} &= 1 * ((1.39 - 0.94)/1.39) * 11,250 * 0.0053 * 0.95 \\ &= 18.3 \text{ Therms} \end{aligned}$$

**For example**, a direct installed bathroom faucet in an Elementary School with gas DHW:

$$\begin{aligned} \Delta\text{Therms} &= 1 * ((1.39 - 0.94)/1.39) * 3,000 * 0.0044 * 0.95 \\ &= 4.06 \text{ Therms} \end{aligned}$$

### WATER IMPACT DESCRIPTIONS AND CALCULATION

$$\Delta\text{Water (gallons)} = ((\text{GPM}_{\text{base}} - \text{GPM}_{\text{low}})/\text{GPM}_{\text{base}}) * \text{Usage} * \text{ISR}$$

Variables as defined above.

**For example**, a direct installed faucet in a large office:

$$\begin{aligned} \Delta\text{Water (gallons)} &= ((1.39 - 0.94)/1.39) * 11,250 * 0.95 \\ &= 3,640 \text{ gallons} \end{aligned}$$

**For example**, a direct installed faucet in an Elementary School:

$$\begin{aligned} \Delta\text{Water (gallons)} &= ((1.39 - 0.94)/1.39) * 3,000 * 0.95 \\ &= 971 \text{ gallons} \end{aligned}$$

### DEEMED O&M COST ADJUSTMENT CALCULATION

N/A

### SOURCES USED FOR GPM ASSUMPTIONS

Source ID	Reference
1	2011, DeOreo, William. California Single Family Water Use Efficiency Study. April 20, 2011.
2	2000, Mayer, Peter, William DeOreo, and David Lewis. Seattle Home Water Conservation Study. December 2000.
3	1999, Mayer, Peter, William DeOreo. Residential End Uses of Water. Published by AWWA Research Foundation and American Water Works Association. 1999.
4	2003, Mayer, Peter, William DeOreo. Residential Indoor Water Conservation Study. Aquacraft, Inc. Water Engineering and Management. Prepared for East Bay Municipal Utility District and the US EPA. July 2003.
5	2011, DeOreo, William. Analysis of Water Use in New Single Family Homes. By Aquacraft. For Salt Lake City Corporation and US EPA. July 20, 2011.
6	2011, Aquacraft. Albuquerque Single Family Water Use Efficiency and Retrofit Study. For Albuquerque Bernalillo County Water Utility Authority. December 1, 2011.

<sup>437</sup> Review of AHRI Directory suggests range of recovery efficiency ratings for new Gas DHW units of 70-87%. Average of existing units is estimated at 75%. Commercial properties are more similar to MF homes than SF homes. MF hot water is often provided by a larger commercial boiler. This suggests that the average recovery efficiency is somewhere between a typical central boiler efficiency of .59 and the .75 for single family home. An average is used for this analysis by default.



Source ID	Reference
7	2008, Schultdt, Marc, and Debra Tachibana. Energy related Water Fixture Measurements: Securing the Baseline for Northwest Single Family Homes. 2008 ACEEE Summer Study on Energy Efficiency in Buildings.

**MEASURE CODE: CI-HWE-LFFA-V12-240101**

**REVIEW DEADLINE: 1/1/2026**

### 4.3.3 Low Flow Showerheads

#### DESCRIPTION

This measure relates to the direct installation of a low flow showerhead in a commercial building. Expected applications include small business, office, restaurant, or small motel. For multifamily or senior housing, the residential low flow showerhead should be used.

This measure was developed to be applicable to the following program types: DI. If applied to other program types, the measure savings should be verified

#### DEFINITION OF EFFICIENT EQUIPMENT

To qualify for this measure the installed equipment must be an energy efficient showerhead rated at 2.0 gallons per minute (GPM) or less. Savings are calculated on a per showerhead fixture basis.

#### DEFINITION OF BASELINE EQUIPMENT

The baseline condition is assumed to be a standard showerhead rated at 2.5 GPM.

#### DEEMED LIFETIME OF EFFICIENT EQUIPMENT

The expected measure life is assumed to be 10 years.<sup>438</sup>

#### DEEMED MEASURE COST

The actual full install cost (including labor) should be used. If unknown, assume \$12 per showerhead.<sup>439</sup>

#### LOADSHAPE

Loadshape C02 - Commercial Electric DHW

#### COINCIDENCE FACTOR

The coincidence factor for this measure is assumed to be 2.78%.<sup>440</sup>

---



---

#### Algorithm

---

#### CALCULATION OF SAVINGS<sup>441</sup>

##### ELECTRIC ENERGY SAVINGS

Note these savings are per showerhead fixture

$\Delta kWh =$

$\%ElectricDHW * ((GPM\_base * L\_base - GPM\_low * L\_low) * NSPD * 365.25) * EPG\_electric * ISR$

Where:

---

<sup>438</sup> Table C-6, Measure Life Report, Residential and Commercial/Industrial Lighting and HVAC Measures, GDS Associates, June 2007. Evaluations indicate that consumer dissatisfaction may lead to reductions in persistence, particularly in Multi-Family.

<sup>439</sup> Direct-install price per showerhead assumes cost of showerhead (Market research average of \$7 and assess and install time of \$5 (20min @ \$15/hr).

<sup>440</sup> Calculated as follows: Assume 11% showers take place during peak hours (as sourced from “Analysis of Water Use in New Single Family Homes, Aquacraft Water Engineering and Management, January 2011). There are 65 days in the summer peak period, so the percentage of total annual aerator use in peak period is  $0.11 * 65 / 365 = 1.96\%$ . The number of hours of recovery during peak periods is therefore assumed to be  $1.96\% * 369 = 7.23$  hours of recovery during peak period. There are 260 hours in the peak period, so the probability you will see savings during the peak period is  $7,23 / 260 = 0.0278$ .

<sup>441</sup>Based on excel spreadsheet 120911.xls ...on IL-TRM SharePoint.

%ElectricDHW = proportion of water heating supplied by electric resistance heating  
 = 1 if electric DHW; 0 if fuel DHW; if unknown, assume 27.6% <sup>442</sup>

GPM\_base = Flow rate of the baseline showerhead  
 = 2.67 for Direct-install programs<sup>443</sup>

GPM\_low = As-used flow rate of the low-flow showerhead, which may, as a result of measurements of program evaluations deviate from rated flows, see table below:

Rated Flow
2.0 GPM
1.75 GPM
1.5 GPM
Custom or Actual <sup>444</sup>

L\_base = Shower length in minutes with baseline showerhead  
 = 8.20 min<sup>445</sup>

L\_low = Shower length in minutes with low-flow showerhead  
 = 8.20 min<sup>446</sup>

365.25 = Days per year, on average.

NSPD = Estimated number of showers taken per day for one showerhead

EPG\_electric = Energy per gallon of hot water supplied by electric  
 =  $(8.33 * 1.0 * (\text{ShowerTemp} - \text{SupplyTemp})) / (\text{RE\_electric} * 3412)$   
 =  $(8.33 * 1.0 * (101 - 50.7)) / (0.98 * 3412)$   
 = 0.125 kWh/gal

8.33 = Specific weight of water (lbs/gallon)

1.0 = Heat Capacity of water (btu/lb-°F)

ShowerTemp = Assumed temperature of water  
 = 101°F <sup>447</sup>

SupplyTemp = Assumed temperature of water entering house

<sup>442</sup> Based on Applied Energy Group, 2016 'Ameren Illinois Demand Side Management Market Potential Study: Volume 4 – APPENDICES'.

<sup>443</sup> Based on measured data from Ameren IL EM&V of Direct-Install program. Program targets showers that are rated 2.5 GPM or above.

<sup>444</sup> Note that actual values may be either a) program-specific minimum flow rate, or b) program-specific evaluation-based value of actual effective flow-rate due to increased duration or temperatures. The latter increases in likelihood as the rated flow drops and may become significant at or below rated flows of 1.5 GPM. The impact can be viewed as the inverse of the throttling described in the footnote for baseline flowrate.

<sup>445</sup> Representative value from sources 1, 2, 3, 4, 5, and 6 (See Source Table at end of measure section).

<sup>446</sup> Set equal to L\_base.

<sup>447</sup> Cadmus and Opinion Dynamics Showerhead and Faucet Aerator Meter Study Memorandum dated June 2013, directed to Michigan Evaluation Working Group.

- = 50.7°F <sup>448</sup>
- RE\_electric = Recovery efficiency of electric water heater  
= 98% <sup>449</sup>
- 3412 = Converts Btu to kWh (btu/kWh)
- ISR = In service rate of showerhead  
= Dependant on program delivery method as listed in table below

Selection	ISR
Direct Install or Guided Self-Install	0.98 <sup>450</sup>
Leave-Behind Kit	0.94 <sup>451</sup>

**For example**, a direct-installed 1.5 GPM showerhead in an office with electric DHW where the number of showers is estimated at 3 per day:

$$\begin{aligned} \Delta kWh &= 1 * ((2.67*8.20)-(1.5*8.20)) * 3*365.25) * 0.125 * 0.98 \\ &= 1288 \text{ kWh} \end{aligned}$$

Secondary kWh Savings for Water Supply and Wastewater Treatment

The following savings should be included in the total savings for this measure but should not be included in TRC tests to avoid double counting the economic benefit of water savings.

$$\Delta kWh_{\text{water}} = \Delta \text{Water (gallons)} / 1,000,000 * E_{\text{water total}}$$

Where

$$\begin{aligned} E_{\text{water total}} &= \text{IL Total Water Energy Factor (kWh/Million Gallons)} \\ &= 5,010^{452} \end{aligned}$$

**For example**, a direct-installed 1.5 GPM showerhead in an office with where the number of showers is estimated at 3 per day:

$$\begin{aligned} \Delta \text{Water (gallons)} &= ((2.67 * 8.20)-(1.5 * 8.20)) * 3 * 365.25 * 0.98 \\ &= 10,302 \text{ gallons} \\ \Delta kWh_{\text{water}} &= 10,302/1,000,000*5,010 \\ &= 52 \text{ kWh} \end{aligned}$$

<sup>448</sup> Table 4 in Chen, et. al., "Calculating Average Hot Water Mixes of Residential Plumbing Fixtures", June 2020, reports a value of 50.7°F for inlet water temperature for U.S. Census Division 3.

<sup>449</sup> Electric water heaters have recovery efficiency of 98%, as sourced from available products on the AHRI Certification Directory.

<sup>450</sup> Deemed values are from ComEd Energy Efficiency/ Demand Response Plan: Plan Year 2 (6/1/2009-5/31/2010) Evaluation Report: All Electric Single Family Home Energy Performance Tune-Up Program Table 3-8. Alternative ISRs may be developed for program delivery methods based on evaluation results.

<sup>451</sup> Based on DCEO STEP Program GPY5 evaluation report for showerheads and aerators. Guidehouse, *In-Service Rates for a CY2020 Business Remote Assessment Path for Customer Installed Measures*, August 21, 2020.

<sup>452</sup> This factor include 2571 kWh/MG for water supply based on Illinois energy intensity data from a 2012 ISAWWA study and 2439 kWh/MG for wastewater treatment based on national energy intensity use estimates. For more information please review Elevate Energy’s ‘IL TRM: Energy per Gallon Factor, May 2018 paper’.

**SUMMER COINCIDENT PEAK DEMAND SAVINGS**

$$\Delta kW = \Delta kWh/Hours * CF$$

Where:

$\Delta kWh$  = calculated value above. Note do not include the secondary savings in this calculation.

Hours = Annual electric DHW recovery hours for showerhead use  
 = ((GPM\_base \* L\_base) \* NSPD \* 365.25 ) \* 0.608<sup>453</sup> / GPH

Where:

GPH = Gallons per hour recovery of electric water heater calculated for 89.3F temp rise (140-50.7), 98% recovery efficiency, and typical 12kW electric resistance storage tank.  
 = 53.9

CF = Coincidence Factor for electric load reduction  
 = 0.0278<sup>454</sup>

**For example**, a direct-installed 1.5 GPM showerhead in an office with electric DHW where the number of showers is estimated at 3 per day:

$$\begin{aligned} \Delta kW &= (1288 / 271) * 0.0278 \\ &= 0.132 \text{ kW} \end{aligned}$$

**FOSSIL FUEL IMPACT DESCRIPTIONS AND CALCULATION**

$$\Delta \text{Therms} = \% \text{FossilDHW} * ((\text{GPM\_base} * \text{L\_base} - \text{GPM\_low} * \text{L\_low}) * \text{NSPD} * 365.25) * \text{EPG\_gas} * \text{ISR}$$

Where:

$\% \text{FossilDHW}$  = proportion of water heating supplied by fossil fuel heating

DHW fuel	$\% \text{Fossil\_DHW}$
Electric	0%
Fossil Fuel	100%
Unknown	72.4% <sup>455</sup>

$$\begin{aligned} \text{EPG\_gas} &= \text{Energy per gallon of Hot water supplied by gas} \\ &= (8.33 * 1.0 * (\text{ShowerTemp} - \text{SupplyTemp})) / (\text{RE\_gas} * 100,000) \\ &= 0.0063 \text{ Therm/gal} \end{aligned}$$

<sup>453</sup> 60.8% is the proportion of hot 140°F water mixed with 50.7°F supply water to give 105°F shower water.

<sup>454</sup> Calculated as follows: Assume 11% showers take place during peak hours (as sourced from “Analysis of Water Use in New Single Family Homes, Aquacraft Water Engineering and Management, January 2011). There are 65 days in the summer peak period, so the percentage of total annual aerator use in peak period is 0.11\*65/365.25 = 1.96%. The number of hours of recovery during peak periods is therefore assumed to be 1.96% \* 369 = 7.23 hours of recovery during peak period where 369 equals the average annual electric DHW recovery hours for showerhead use including SF and MF homes with Direct Install and Retrofit/TOS measures. There are 260 hours in the peak period so the probability you will see savings during the peak period is 7.23/260 = 0.0278.

<sup>455</sup> Based on Applied Energy Group, 2016 'Ameren Illinois Demand Side Management Market Potential Study: Volume 4 – APPENDICES'.

Where:

RE\_gas = Recovery efficiency of gas water heater  
 = 67%<sup>456</sup>  
 100,000 = Converts Btus to Therms (btu/Therm)

Other variables as defined above.

**For example**, a direct-installed 1.5 GPM showerhead in an office with gas DHW where the number of showers is estimated at 3 per day:

$$\begin{aligned} \Delta\text{Therms} &= 1.0 * ((2.67 * 8.2) - (1.5 * 8.2)) * 3 * 365.25 * 0.0063 * 0.98 \\ &= 64.9 \text{ therms} \end{aligned}$$

### WATER IMPACT DESCRIPTIONS AND CALCULATION

$$\Delta\text{Water (gallons)} = ((\text{GPM}_{\text{base}} * L_{\text{base}} - \text{GPM}_{\text{low}} * L_{\text{low}}) * \text{NSPD} * 365.25 * \text{ISR})$$

Variables as defined above

**For example**, a direct-installed 1.5 GPM showerhead in an office with where the number of showers is estimated at 3 per day:

$$\begin{aligned} \Delta\text{Water (gallons)} &= ((2.67 * 8.20) - (1.5 * 8.20)) * 3 * 365.25 * 0.98 \\ &= 10,302 \text{ gallons} \end{aligned}$$

### DEEMED O&M COST ADJUSTMENT CALCULATION

N/A

### SOURCES

Source ID	Reference
1	2011, DeOreo, William. California Single Family Water Use Efficiency Study. April 20, 2011.
2	2000, Mayer, Peter, William DeOreo, and David Lewis. Seattle Home Water Conservation Study. December 2000.
3	1999, Mayer, Peter, William DeOreo. Residential End Uses of Water. Published by AWWA Research Foundation and American Water Works Association. 1999.
4	2003, Mayer, Peter, William DeOreo. Residential Indoor Water Conservation Study. Aquacraft, Inc. Water Engineering and Management. Prepared for East Bay Municipal Utility District and the US EPA. July 2003.
5	2011, DeOreo, William. Analysis of Water Use in New Single Family Homes. By Aquacraft. For Salt Lake City Corporation and US EPA. July 20, 2011.
6	2011, Aquacraft. Albuquerque Single Family Water Use Efficiency and Retrofit Study. For Albuquerque Bernalillo County Water Utility Authority. December 1, 2011.
7	2008, Schultdt, Marc, and Debra Tachibana. Energy related Water Fixture Measurements: Securing the Baseline for Northwest Single Family Homes. 2008 ACEEE Summer Study on Energy Efficiency in Buildings.

<sup>456</sup> Review of AHRI Directory suggests range of recovery efficiency ratings for new Gas DHW units of 70-87%. Average of existing units is estimated at 75%. Commercial properties are more similar to MF homes than SF homes. MF hot water is often provided by a larger commercial boiler. This suggests that the average recovery efficiency is somewhere between a typical central boiler efficiency of .59 and the .75 for single family home. An average is used for this analysis by default.

**MEASURE CODE: CI-HWE-LFSH-V09-230101**

**REVIEW DEADLINE: 1/1/2024**

#### 4.3.4 Commercial Pool Covers

##### **DESCRIPTION**

This measure refers to the installation of covers on commercial use pools that are heated with gas-fired equipment located either indoors or outdoors. By installing pool covers, the heating load on the pool boiler will be reduced by reducing the heat loss from the water to the environment and the amount of actual water lost due to evaporation (which then requires additional heated water to make up for it). An additional benefit to pool covers are the electricity savings from the reduced fresh water required to replace the evaporated water.

The main source of energy loss in pools is through evaporation. This is particularly true of outdoor pools where wind plays a larger role. The point of installing pool covers is threefold. First, it will reduce convective losses due to the wind by shielding the water surface. Second, it will insulate the water from the colder surrounding air. And third, it will reduce radiative losses to the night sky. In doing so, evaporative losses will also be minimized, and the boiler will not need to work as hard in replenishing the pool with hot water to keep the desired temperature.

This measure can be used for pools that (1) currently do not have pool covers, (2) have pool covers that are past the useful life of the existing cover, or (3) have pool covers that are past their warranty period and have failed. Please note, IECC 2021 requires pool covers in outdoor applications, making this measure ineligible for new construction projects with outdoor pools. IECC 2021 is expected to become effective statewide in 2023 and is the baseline for all New Construction permits from that date onward. As code requirements and adoption can differ from municipality to municipality, the user should verify which version of code is applicable given these constraints.

##### **DEFINITION OF EFFICIENT EQUIPMENT**

For indoor pools, the efficient case is the installation of an indoor pool cover with a 5 year warranty on an indoor pool that operates all year.

For outdoor pools, the efficient case is the installation of an outdoor pool cover with a 5 year warranty on an outdoor pool that is open through the summer season.

##### **DEFINITION OF BASELINE EQUIPMENT**

For indoor pools, the base case is an uncovered indoor pool that operates all year.

For outdoor pools, the base case is an outdoor pool that is uncovered and is open through the summer season.

##### **DEEMED LIFETIME OF EFFICIENT EQUIPMENT**

The useful life of this measure is assumed to be 6 years.<sup>457</sup>

##### **DEEMED MEASURE COST**

The table below shows the costs for the various options and cover sizes. Since this measure covers a mix of various sizes, the average cost of these options is taken to be the incremental measure cost.<sup>458</sup> Costs are per square foot.

---

<sup>457</sup> The effective useful life of a pool cover is typically one year longer than its warranty period. SolaPool Covers. Pool Covers Website, FAQ- "How long will my SolaPool cover blanket last?". Pool covers are typically offered with 3 and 5 year warranties with at least one company offering a 6 year warranty. Conversation with Trade Ally. Knorr Systems.

<sup>458</sup> Pool Cover Costs: Lincoln Commercial Pool Equipment online catalog. Accessed 8/26/11.



Cover Size	Edge Style	
	Hemmed (indoor)	Weighted (outdoor)
1000-1,999 sq. ft.	\$2.19	\$2.24
2,000-2,999 sq. ft.	\$2.01	\$2.06
3,000+ sq. ft.	\$1.80	\$1.83
Average	\$2.00	\$2.04

**LOADSHAPE**

Loadshape R15 – Residential Pool Pumps

**COINCIDENCE FACTOR**

N/A

---

**Algorithm**

---

**CALCULATION OF ENERGY SAVINGS**

**ELECTRIC ENERGY SAVINGS**

Secondary kWh Savings for Water Supply and Wastewater Treatment

The following savings should be included in the total savings for this measure but should not be included in TRC tests to avoid double counting the economic benefit of water savings.

$$\Delta kWh_{water} = \Delta Water \text{ (gallons)} / 1,000,000 * E_{water \text{ supply}}$$

Where

$$E_{water \text{ supply}} = \text{Water Supply Energy Factor (kWh/Million Gallons)}$$

$$= 2,571^{459}$$

---

<sup>459</sup> This factor include 2571 kWh/MG for water supply based on Illinois energy intensity data from a 2012 ISAWWA study. For more information please review Elevate Energy’s ‘IL TRM: Energy per Gallon Factor, May 2018 paper’. Note since the water loss associated with this measure is due to evaporation and does not discharge into the wastewater system, only the water supply factor is used here.

**For example,**

2400ft<sup>2</sup> Indoor Swimming Pool:

$$\begin{aligned} \Delta\text{Water} &= \text{WaterSavingFactor} \times \text{Size of Pool} \\ &= 15.28 \text{ gal./ft}^2/\text{year} \times 2400 \text{ ft}^2 \\ &= 36,672 \text{ gal./year} \end{aligned}$$

$$\begin{aligned} \Delta\text{kWhwater} &= \Delta\text{Water} / 1,000,000 * E_{\text{water supply}} \\ &= 36,672 \text{ gal./year} / 1,000,000 * 2,571 \text{ kWh/million gallons} \\ &= 96.3 \text{ kWh/year} \end{aligned}$$

2400ft<sup>2</sup> Outdoor Swimming Pool:

$$\begin{aligned} \Delta\text{Water} &= \text{WaterSavingFactor} \times \text{Size of Pool} \\ &= 8.94 \text{ gal./ft}^2/\text{year} \times 2400 \text{ ft}^2 \\ &= 21,456 \text{ gal./year} \end{aligned}$$

$$\begin{aligned} \Delta\text{kWhwater} &= \Delta\text{Water} / 1,000,000 * E_{\text{water supply}} \\ &= 21,456 \text{ gal./year} / 1,000,000 * 2,571 \text{ kWh/million gallons} \\ &= 55.2 \text{ kWh/year} \end{aligned}$$

**SUMMER COINCIDENT PEAK DEMAND SAVINGS**

N/A

**FOSSIL FUEL SAVINGS**

The calculations are based on modeling runs using RSPEC! Energy Smart Pools Software that was created by the U.S. Department of Energy.<sup>460</sup>

$$\Delta\text{Therms} = \text{SavingFactor} \times \text{Size of Pool}$$

Where

Savings factor = dependant on pool location and listed in table below:<sup>461</sup>

Location	Therm / sq-ft
Indoor	2.61
Outdoor	1.01

Size of Pool = custom input

**WATER IMPACT DESCRIPTIONS AND CALCULATION**

$$\Delta\text{Water (gallons)} = \text{WaterSavingFactor} \times \text{Size of Pool}$$

Where

WaterSavingFactor = Water savings for this measure dependant on pool location and listed in table below:<sup>462</sup>

<sup>460</sup> Full method and supporting information found in reference document: IL TRM - Business Pool Covers WorkPaper.docx. Note that the savings estimates are based upon Chicago weather data.

<sup>461</sup> Business Pool Covers.xlsx

<sup>462</sup> Ibid.

Location	Annual Savings Gal / sq-ft
Indoor	15.28
Outdoor	8.94

Size of Pool = Custom input

**DEEMED O&M COST ADJUSTMENT CALCULATION**

There are no O&M cost adjustments for this measure.

**MEASURE CODE: CI-HWE-PLCV-V05-240101**

**REVIEW DEADLINE: 1/1/2025**

#### 4.3.5 Tankless Water Heater – Measure combined with 4.3.1 Water Heater in Version 8

## 4.3.6 Ozone Laundry

### DESCRIPTION

A new ozone laundry system(s) is added-on to new or existing commercial washing machine(s) using hot water heated with natural gas. The system generates ozone (O<sub>3</sub>), a naturally occurring molecule, which helps clean fabrics by chemically reacting with soils in cold water. Adding an ozone laundry system(s) will reduce the amount of chemicals, detergents, and hot water needed to wash linens. Using ozone also reduces the total amount of water consumed, saving even more in energy.

Natural gas energy savings will be achieved at the hot water heater/boiler as they will be required to produce less hot water to wash each load of laundry. The decrease in hot water usage will increase cold water usage, but overall water usage at the facility will decrease.

Electric savings can be realized through reduced washer cycle length and reduced pumping load at the boiler feeding the commercial washers. The increased usage associated with operating the ozone system should also be accounted for when determining total kWh impact. Data reviewed for this measure characterization indicated that pumping savings should be accounted for, but washer savings and ozone generator consumption are comparatively so small that they can be ignored.

The reduced washer cycle length may decrease the dampness of the clothes when they move to the dryer. This can result in shorter runtimes which result in gas and electrical savings. However, at this time, there is inconclusive evidence that energy savings are achieved from reduced dryer runtimes so the resulting dryer effects are not included in this analysis. Additionally, there would be challenges verifying that dryer savings will be achieved throughout the life of the equipment.

This incentive only applies to the following facilities with on-premise laundry operations:

- Hotels/motels
- Fitness and recreational sports centers.
- Healthcare (excluding hospitals)
- Assisted living facilities
- Laundromats

Ozone laundry system(s) could create significant energy savings opportunities at other larger facility types with on-premise laundry operations (such as correctional facilities, universities, and staff laundries), however, the results included in this analysis are based heavily on past project data for the applicable facility types listed above and may not apply to facilities outside of this list due to variances in number of loads and average pound (lbs.)-capacity per project site. Projects at these facilities should continue to be evaluated through custom programs and the applicable facility types and the resulting analysis should be updated based on new information.

Laundromats are the only application where number of washing units needs to be used to calculate total site energy savings. All other applications use site assumptions to calculate total site savings.

This measure was developed to be applicable to the following program types: TOS, RF. If applied to other program types, the measure savings should be verified.

### DEFINITION OF EFFICIENT EQUIPMENT

A new ozone laundry system(s) is added-on to new or existing commercial washing machine(s) using hot water heated with natural gas. The ozone laundry system(s) must transfer ozone into the water through:

- Venturi Injection
- Bubble Diffusion
- Additional applications may be considered upon program review and approval on a case by case basis
- For laundromats, the ozone laundry system(s) must be connected to both the hot and cold water inlets of the clothes washing machine(s) so that hot water is no longer provided to the clothes washer.

**DEFINITION OF BASELINE EQUIPMENT**

The base case equipment is a conventional washing machine system with no ozone generator installed. The washing machines are provided hot water from a gas-fired boiler.

**DEEMED LIFETIME OF EFFICIENT EQUIPMENT**

The measure equipment effective useful life (EUL) is estimated at 10 years based on typical lifetime of the ozone generator’s corona discharge unit.<sup>463</sup>

**DEEMED MEASURE COST**

The actual measure costs should be used if available. If not, the following deemed values should be used:

Application	Deemed Measure Cost
Laundromat	\$25.53 / lbs capacity <sup>464</sup>
Hotel/Motel	\$79.84 / lbs capacity <sup>465</sup>
Fitness and Recreation	
Healthcare	
Assisted Living	

**LOADSHAPE**

Loadshape C53 – Flat

**COINCIDENCE FACTOR**

Past project documentation and data collection is not sufficient to determine a coincidence factor for this measure. Value should continue to be studied and monitored through additional studies due to limited data points used for this determination.

---

**Algorithm**

---

**CALCULATION OF ENERGY SAVINGS**

**ELECTRIC ENERGY SAVINGS**

Electric savings can be realized through reduced washer cycle length and reduced pumping load at the boiler feeding the commercial washers. There is also an increased usage associated with operating the ozone system. Data reviewed for this measure characterization indicated that while pumping savings is significant and should be accounted for, washer savings and ozone generator consumption are negligible, counter each other out and are well within the margin of error so these are not included to simplify the characterization.<sup>466</sup>

$$\Delta kWh_{PUMP} = HP * HP_{CONVERSION} * Hours * \%water\_savings$$

<sup>463</sup> Aligned with other national energy efficiency programs and confirmed with national vendors

<sup>464</sup> Average cost per unit of capacity for laundromats was generated using data collected from previous Peoples Gas and North Shore Gas custom projects

<sup>465</sup> Average costs per unit of capacity were generated using data collected from existing ozone laundry projects that received incentives under the Non-Residential Retrofit Demand Reduction program (NRR-DR), as well as from the Nicor Custom Incentive Program, and the Nicor Emerging Technology Program (ETP). See referenced document Table 2 and RSMMeans Mechanical Cost Data, 31st Annual Edition (2008)

<sup>466</sup> Washer savings were reviewed but were considered negligible and not included in the algorithm (0.00082 kWh / lbs-capacity, determined through site analysis through Nicor Emerging Technology Program (ETP) and confirmed with national vendors). Note that washer savings from Nicor’s site analysis are smaller than those reported in a WI Focus on Energy case study (0.23kWh/100lbs, Hampton Inn Brookfield, November 2010). Electric impact of operating ozone generator (0.0021 kWh / lbs-capacity same source as washer savings) was also considered negligible and not included in calculations. Values should continue to be studied and monitored through additional studies due to limited data points used for this determination.

Where:

- $\Delta kWh_{PUMP}$  = Electric savings from reduced pumping load
- HP = Brake horsepower of boiler feed water pump;  
= Actual, or use 5 HP if unknown<sup>467</sup>
- $HP_{CONVERSION}$  = Conversion from Horsepower to Kilowatt  
= 0.746
- Hours = Actual associated boiler feed water pump hours  
= Must be a custom calculation for laundromats, but 800 hours can be used for other applications if unknown<sup>468</sup>
- %water\_savings = water reduction factor: how much more efficient an ozone injection washing machine is compared to a typical conventional washing machine as a rate of hot and cold water reduction.

Application	%water_savings
Laundromat	10% <sup>469</sup>
Hotel/Motel	25% <sup>470</sup>
Fitness and Recreation	
Healthcare	
Assisted Living	

Using defaults above:

$$\Delta kWh_{PUMP\_LAUNDROMAT} = 5 * 0.746 * \text{Hours} * 0.10$$

$$= 0.373 \text{ kWh} * \text{Hours}$$

$$\Delta kWh_{PUMP\_ALL\ OTHER} = 5 * 0.746 * 800 * 0.25$$

$$= 746 \text{ kWh}$$

Default per pound: =  $\Delta kWh_{PUMP} / \text{Lbs-Capacity}$

Where:

Lbs-Capacity = Total washer capacity measured in pounds of laundry

Application	Lbs-Capacity
Laundromat	Actual combined capacity of ozone connected washers
Hotel/Motel	254.38 lbs per site <sup>471</sup>
Fitness and Recreation	

<sup>467</sup> Assumed average horsepower for boilers connected to applicable washer.

<sup>468</sup> Engineered estimate provided by CLEAResult review of Nicor custom projects. Machines spent approximately 7 minutes per hour filling with water and were in operation approximately 20 hours per day. Total pump time therefore estimated as  $7/60 * 20 * 365 = 852$  hours, and rounded down conservatively to 800 hours.

<sup>469</sup> Page 7, Laundries and Dry-Cleaning Operations, Watersmart Guidebook EBMUD\_WaterSmart\_Guide\_Laundries\_Dry-Cleaning\_Operations.pdf.

<sup>470</sup> Average water reduction factors were generated using data collected from existing ozone laundry projects that received incentives under the Non-Residential Retrofit Demand Reduction program (NRR-DR). Table 6 summarizes data gathered from several NRR-DR projects, Nicor Custom projects, and Nicor ETP projects. Nicor Savings Numbers are associated with ACEE\_AWE\_Ozone Laundry / From Gas Savings Calculations.

<sup>471</sup> Average lbs-capacity per project site was generated using data collected from existing ozone laundry projects that received incentives under the Non-Residential Retrofit Demand Reduction program (NRR-DR), as well as from the Nicor Custom Incentive Program, and the Nicor Emerging Technology Program (ETP). See referenced document Table 2.

Application	Lbs-Capacity
Healthcare	
Assisted Living	

$$\Delta kWh_{PUMP\ ALL\ OTHERS} \text{ per pound} = 746/254.38$$

$$= 2.93 \text{ kWh/lb}$$

Secondary kWh Savings for Water Supply and Wastewater Treatment

The following savings should be included in the total savings for this measure, but should not be included in TRC tests to avoid double counting the economic benefit of water savings.

$$\Delta kWh_{water} = \Delta Water \text{ (gallons)} / 1,000,000 * E_{water\ total}$$

Where:

$$\Delta Water \text{ (gallons)}_{LAUNDROMAT} = 239 * Lbs\_Capacity^{472}$$

$$\Delta Water \text{ (gallons)}_{ALL\ OTHERS} = 464,946^{473}$$

$$E_{water\ total} = \text{IL Total Water Energy Factor (kWh/Million Gallons)}$$

$$= 5,010^{474}$$

Deemed savings using defaults:

$$\Delta kWh_{water\_LAUNDROMAT} = (239 * Lbs-Cpacity)/1,000,000 * 5,010$$

$$\Delta kWh_{water\_ALL\ OTHERS} = 464,946/1,000,000 * 5,010$$

$$= 2,329 \text{ kWh}$$

**SUMMER COINCIDENT PEAK DEMAND SAVINGS**

Past project documentation and data collection is not sufficient to determine summer coincident peak demand savings for this measure. Value should continue to be studied and monitored through additional studies due to limited data points used for this determination. In absence of site-specific data, the summer coincident peak demand savings should be assumed to be zero.

$$\Delta kW = 0$$

**FOSSIL FUEL SAVINGS**

$$\Delta Therm = Therm_{Baseline} * \%hot\_water\_savings$$

Where:

$$\Delta Therm = \text{Gas savings resulting from a reduction in hot water use, in therm.}$$

$$Therm_{Baseline} = \text{Annual Baseline Gas Consumption}$$

$$= WHE * WUtiliz * WUsage\_hot$$

Where:

$$WHE = \text{water heating energy: energy required to heat the hot water used}$$

<sup>472</sup> See the “Water Impact Descriptions and Calculation” section of this measure for more information.

<sup>473</sup> See the “Water Impact Descriptions and Calculation” section of this measure for more information.

<sup>474</sup> This factor include 2571 kWh/MG for water supply based on Illinois energy intensity data from a 2012 ISAWWA study and 2439 kWh/MG for wastewater treatment based on national energy intensity use estimates. For more information please review Elevate Energy’s ‘IL TRM: Energy per Gallon Factor, May 2018 paper’.



$$= 0.00885 \text{ therm/gallon}^{475}$$

WUtiliz = washer utilization factor: the annual pounds of clothes washed per year  
 = actual, if unknown the values below:

Application	WUtiliz
Laundromat	2,190 <sup>476</sup> cycles per year * Lbs-Capacity
Hotel/Motel	916,150 lbs <sup>477</sup> (Approx. 4,745 cycles per year) per site
Fitness and Recreation	
Healthcare	
Assisted Living	

WUsage\_hot = hot water usage factor: how much hot water a typical conventional washing machine utilizes, normalized per pounds of clothes washed

Application	WUsage_hot
Laundromat	0.64 gallons/lb <sup>478</sup>
Hotel/Motel	1.19 gallons/lb <sup>479</sup>
Fitness and Recreation	
Healthcare	
Assisted Living	

Using defaults above:

$$\begin{aligned} \text{Therm}_{\text{Baseline\_LAUNDROMAT}} &= 0.00885 * (2,190 \text{ cycles per year} * \text{Lbs-Capacity}) * 0.64 \\ &= 12.4 \text{ therms} * \text{Lbs-Capacity} \end{aligned}$$

$$\begin{aligned} \text{Therm}_{\text{Baseline\_ALL OTHERS}} &= 0.00885 * 916,150 * 1.19 \\ &= 9648 \text{ therms} \end{aligned}$$

%hot\_water\_savings = hot water reduction factor: how much more efficient an ozone injection washing machine is, compared to a typical conventional washing machine, as a rate of hot water reduction

Application	%hot_water_savings
Laundromat	100%
Hotel/Motel	81% <sup>480</sup>
Fitness and Recreation	
Healthcare	

<sup>475</sup> Assuming boiler efficiency is the regulated minimum efficiency (80%), per Title 20 Appliance Standard of the California Energy Regulations (October 2007). The incoming municipal water temperature is assumed to be 55°F with an average hot water supply temperature of 140°F, based on default test procedures on clothes washers set by the Department of Energy’s Office of Energy Efficiency and Renewable Energy (Federal Register, Vol. 52, No. 166). Enthalpies for these temperatures (107 btu/lbs at 140°F, 23.07 btu/lbs at 55°F) were obtained from ASHRAE Fundamentals.

<sup>476</sup> DOE Technical Support Document Chapter 6, 2010 <https://www.regulations.gov/contentStreamer?documentId=EERE-2006-STD-0127-0118&attachmentNumber=8&disposition=attachment&contentType=pdf>

<sup>477</sup> Average utilization factors were generated using data collected from existing ozone laundry projects that received incentives under the NRR-DR program. Table 3 summarizes data gathered from several NRR-DR projects, Nicor Custom projects, and Nicor ETP projects.

<sup>478</sup> Calculated as WUsage \* Average % Hot water (estimated at 59% from Custom laundromat data); 1.09\*0.59 = 0.64 gal / lbs laundry.

<sup>479</sup> Average hot water usage factors were generated using data collected from existing ozone laundry projects that received incentives under the NRR-DR program. Summarizes data gathered from several NRR-DR projects.

<sup>480</sup> Average hot water reduction factors were generated using data collected from existing ozone laundry projects that received incentives under the Non-Residential Retrofit Demand Reduction program (NRR-DR). Table 5 summarizes data gathered from several NRR-DR projects, Nicor Custom projects, and Nicor ETP projects. Nicor Savings Numbers are associated with ACEE\_AWE\_Ozone Laundry / From Gas Savings Calculations.

Application	%hot_water_savings
Assisted Living	

Savings using defaults above:

$$\begin{aligned} \Delta\text{Therm} &= \text{Therm}_{\text{Baseline}} * \% \text{hot\_water\_savings} \\ \Delta\text{Therm}_{\text{LAUNDROMAT}} &= 12.4 * \text{Lbs-Capacity} * 100\% \\ &= 12.4 \text{ therms} * \text{Lbs-Capacity} \\ \Delta\text{Therm}_{\text{ALL OTHER}} &= 9648 * 81\% \\ &= 7815 \text{ therms per site} \end{aligned}$$

Default per lb capacity:

$$\begin{aligned} \Delta\text{Therm}_{\text{LAUNDROMAT}} / \text{lb} &= 12.4 * \text{Lbs-Capacity} / \text{lb capacity} \\ &= 12.4 \text{ therms} / \text{lb} \\ \Delta\text{Therm}_{\text{ALL OTHER}} / \text{lb} &= 7815 / 254.38 \\ &= 30.7 \text{ therms} / \text{lb} \end{aligned}$$

### WATER IMPACT DESCRIPTIONS AND CALCULATION

The water savings calculations listed here account for the combination of hot and cold water used. Savings calculations for this measure were based on the reduction in total water use from implementing an ozone washing system to the base case. There are three main components in obtaining this value:

$$\Delta\text{Water (gallons)} = \text{WUsage} * \text{WUtiliz} * \% \text{water\_savings}$$

Where:

$\Delta\text{Water (gallons)}$  = reduction in total water use from implementing an ozone washing system to the base case

$\text{WUsage}$  = water usage factor: amount of total water used by a conventional washing machine normalized per unit of clothes washed

$$\text{WUsage}_{\text{LAUNDROMATS}} = 1.09 \text{ gallons} / \text{lbs laundry}^{481}$$

$$\text{WUsage}_{\text{ALL OTHERS}} = 2.03 \text{ gallons/lbs laundry}^{482}$$

$\text{WUtiliz}$  = washer utilization factor: the annual pounds of clothes washed per year

= actual, if unknown use the values below:

Application	WUtiliz
Laundromat	2,190 <sup>483</sup> cycles per year * Lbs-Capacity
Hotel/Motel	916,150 lbs <sup>484</sup> (Approx. 4,745 cycles per year) per site
Fitness and Recreation	
Healthcare	

<sup>481</sup> Based on Peoples Gas custom project data.

<sup>482</sup> Average water usage factors were generated using data collected from existing ozone laundry projects that received incentives under the NRR-DR program. summarizes data gathered from several NRR-DR projects.

<sup>483</sup> DOE Technical Support Document Chapter 6, 2010 <https://www.regulations.gov/contentStreamer?documentId=EERE-2006-STD-0127-0118&attachmentNumber=8&disposition=attachment&contentType=pdf>

<sup>484</sup> Average utilization factors were generated using data collected from existing ozone laundry projects that received incentives under the NRR-DR program. Table 3 summarizes data gathered from several NRR-DR projects, Nicor Custom projects, and Nicor ETP projects.

Application	WUtiliz
Assisted Living	

%water\_savings = water reduction factor: how much more efficient an ozone injection washing machine is compared to a typical conventional washing machine as a rate of hot and cold water reduction.

Application	%water_savings
Laundromat	10% <sup>485</sup>
Hotel/Motel	25% <sup>486</sup>
Fitness and Recreation	
Healthcare	
Assisted Living	

Savings using defaults above:

$$\begin{aligned} \Delta\text{Water} &= \text{WUsage} * \text{WUtiliz} * \% \text{water\_savings} \\ \Delta\text{Water}_{\text{LAUNDROMATS}} &= 1.09 * \text{WUtiliz} * 0.1 \\ &= 1.09 * (2,190 * \text{Lbs-Capacity}) * 0.1 \\ &= 239 * \text{Lbs-Capacity} \\ \Delta\text{Water}_{\text{ALL OTHERS}} &= 2.03 * 916,150 * 0.25 \\ &= 464,946 \text{ gallons per site} \end{aligned}$$

Default per pound:

$$\begin{aligned} \Delta\text{Water}_{\text{LAUNDROMATS}} / \text{lb capacity} &= (239 * \text{Lbs-Capacity}) / \text{lb-capacity} \\ &= 239 \text{ gallons/lb} \\ \Delta \text{Water}_{\text{ALL OTHERS}} / \text{lb-capacity} &= 464,946 / 254.38 \\ &= 1,828 \text{ gallons / lb} \end{aligned}$$

### DEEMED O&M COST ADJUSTMENT CALCULATION

Maintenance is required for the following components annually:<sup>487</sup>

- Ozone Generator: filter replacement, check valve replacement, fuse replacement, reaction chamber inspection/cleaning, reaction chamber o-ring replacement
- Air Preparation – Heat Regenerative: replacement of two medias
- Air Preparation – Oxygen Concentrators: filter replacement, pressure relief valve replacement, compressor rebuild
- Venturi Injector: check valve replacement

<sup>485</sup> Page 7, Laundries and Dry-Cleaning Operations, Watersmart Guidebook EBMUD\_WaterSmart\_Guide\_Laundries\_Dry-Cleaning\_Operations.pdf.

<sup>486</sup> Average water reduction factors were generated using data collected from existing ozone laundry projects that received incentives under the Non-Residential Retrofit Demand Reduction program (NRR-DR). Table 6 summarizes data gathered from several NRR-DR projects, Nicor Custom projects, and Nicor ETP projects. Nicor Savings Numbers are associated with ACEE\_AWE\_Ozone Laundry / From Gas Savings Calculations.

<sup>487</sup> Confirmed through communications with national vendors and available references, via an online forum (The Ozone Laundry Blog – The Importance of Maintenance).

Maintenance is expected to cost \$0.79 / lbs capacity.

#### **SOURCES**

- 1 "Lodging Report", December 2008, California Travel & Tourism Commission,  
[http://tourism.visitcalifornia.com/media/uploads/files/editor/Research/CaliforniaTourism\\_200812.pdf](http://tourism.visitcalifornia.com/media/uploads/files/editor/Research/CaliforniaTourism_200812.pdf)
- 2 "Health, United States, 2008" Table 120, U.S. Department of Health & Human Services, Centers for Disease Control & Prevention, National Center for Health Statistics, <http://www.cdc.gov/nchs/data/hus/hus08.pdf#120>
- 3 Fourth Quarter 2008 Facts and Figures, California Department of Corrections & Rehabilitation (CDCR), [http://www.cdcr.ca.gov/Divisions\\_Boards/Adult\\_Operations/docs/Fourth\\_Quarter\\_2008\\_Facts\\_and\\_Figures.pdf](http://www.cdcr.ca.gov/Divisions_Boards/Adult_Operations/docs/Fourth_Quarter_2008_Facts_and_Figures.pdf)
- 4 Jail Profile Survey (2008), California Department of Corrections & Rehabilitation (CDCR), [http://www.cdcr.ca.gov/Divisions\\_Boards/CSA/FSO/Docs/2008\\_4th\\_Qtr\\_JPS\\_full\\_report.pdf](http://www.cdcr.ca.gov/Divisions_Boards/CSA/FSO/Docs/2008_4th_Qtr_JPS_full_report.pdf)
- 5 DEER2011\_NTGR\_2012-05-16.xls from DEER Database for Energy-Efficient Resources; Version 2011 4.01  
Under: DEER2011 Update Documentation linked at: DEER2011 Update Net-To-Gross table Cells: T56 and U56
- 6 The Benefits of Ozone in Hospitality On-Premise Laundry Operations, PG&E Emerging Technologies Program, Application Assessment Report #0802, April 2009.
- 7 Federal Register, Vol. 52, No. 166
- 8 2009 ASHRAE Handbook – Fundamentals, Thermodynamic Properties of Water at Saturation, Section 1.1 (Table 3), 2009
- 9 Table 2 through 6: Excel file summarizing data collected from existing ozone laundry projects that received incentives under the NRR-DR program
- 10 DOE Technical Support Document Chapter 6, 2010  
<https://www.regulations.gov/contentStreamer?documentId=EERE-2006-STD-0127-0118&attachmentNumber=8&disposition=attachment&contentType=pdf>
- 11 GTI Residential Ozone Laundry Field Demonstration (May 2018)

#### **MEASURE CODE CI-HWE-OZLD-V07-230101**

**REVIEW DEADLINE: 1/1/2026**

### 4.3.7 Multifamily Central Domestic Hot Water Plants

**DESCRIPTION**

This measure covers multifamily central domestic hot water (DHW) plants with thermal efficiencies greater than or equal to 88%. This measure is applicable to any combination of boilers and storage tanks provided the thermal efficiency of the boiler(s) is greater than 88%. Plants providing other than solely DHW are not applicable to this measure.

This measure was developed to be applicable to the following program types: TOS, NC, ER.

If applied to other program types, the measure savings should be verified.

Note, IECC 2021 is expected to become effective statewide in 2023. IECC 2018 is the requisite code for any projects with permitting dates spanning July 1, 2019 to the IECC 2021 effective date. Prior to July 1, 2019, IECC 2015 is the applicable code. As code requirements and adoption can differ from municipality to municipality, the user should verify which version of code is applicable given these constraints.

**DEFINITION OF EFFICIENT EQUIPMENT**

To qualify the boiler(s) must have a Thermal Efficiency of 88% or greater and supply domestic hot water to multi-family buildings.

**DEFINITION OF BASELINE EQUIPMENT**

For TOS, the baseline boiler is assumed to have a Thermal Efficiency of 80%.<sup>488</sup>

For Early Replacement, the savings are calculated between existing unit and efficient unit consumption during the remaining life of the existing unit, and between new baseline unit as above and efficient unit consumption for the remainder of the measure life.

**DEEMED LIFETIME OF EFFICIENT EQUIPMENT**

The measure life for the domestic hot water boilers is 15 years.<sup>489</sup>

**DEEMED MEASURE COST**

TOS: The actual install cost should be used for the efficient case, minus the baseline cost assumption provided below:

Capacity Range	Baseline Installed Cost per kbtuh <sup>490</sup>
< 300 kbtuh	\$65 per kbTUh
300 – 2500 kbtuh	\$38 per kbTUh
> 2500 kbtuh	\$32 per kbTUh

**LOADSHAPE**

N/A

**COINCIDENCE FACTOR**

N/A

<sup>488</sup> International Energy Conservation Code (IECC) 2012/2015/2018/2021, Table C404.2, Minimum Performance of Water-Heating Equipment, hot water supply boiler, gas.

<sup>489</sup> Nicor Gas Energy Efficiency Plan 2011-2014. Revised Plan Filed Pursuant to Order Docket 10-0562, May 27, 2011.

<sup>490</sup> Baseline install costs are based on data from the “2010-2012 WO017 Ex Ante Measure Cost Study”, Itron, California Public Utilities Commission. The data is provided in a file named “MCS Results Matrix – Volume I”.

**Algorithm**

**CALCULATION OF ENERGY SAVINGS**

**ELECTRIC ENERGY SAVINGS**

There are no anticipated electrical savings from this measure.

**SUMMER COINCIDENT PEAK DEMAND SAVINGS**

N/A

**FOSSIL FUEL SAVINGS**

Time of Sale:

$$\begin{aligned} \Delta\text{Therms} &= \text{Hot Water Savings} + \text{Standby Loss Savings} \\ &= \left[ \frac{(\text{MFHH} * \#\text{Units} * \text{GPD} * \text{Days/yr} * \gamma_{\text{Water}} * (T_{\text{out}} - T_{\text{in}}) * (1/\text{Eff}_{\text{base}} - 1/\text{Eff}_{\text{ee}}))}{100,000} \right] + \left[ \frac{(\text{SL} * \text{Hours/yr} * (1/\text{Eff}_{\text{base}} - 1/\text{Eff}_{\text{ee}}))}{100,000} \right] \end{aligned}$$

Early Replacment:<sup>491</sup>

$$\begin{aligned} \Delta\text{Therms for remaining life of existing unit (first 5 years):} \\ &= \left[ \frac{(\text{MFHH} * \#\text{Units} * \text{GPD} * \text{Days/yr} * \gamma_{\text{Water}} * (T_{\text{out}} - T_{\text{in}}) * (1/\text{Eff}_{\text{exist}} - 1/\text{Eff}_{\text{ee}}))}{100,000} \right] + \left[ \frac{(\text{SL} * \text{Hours/yr} * (1/\text{Eff}_{\text{exist}} - 1/\text{Eff}_{\text{ee}}))}{100,000} \right] \end{aligned}$$

$$\begin{aligned} \Delta\text{Therms for remaining measure life (next 10 years):} \\ &= \left[ \frac{(\text{MFHH} * \#\text{Units} * \text{GPD} * \text{Days/yr} * \gamma_{\text{Water}} * (T_{\text{out}} - T_{\text{in}}) * (1/\text{Eff}_{\text{base}} - 1/\text{Eff}_{\text{ee}}))}{100,000} \right] + \left[ \frac{(\text{SL} * \text{Hours/yr} * (1/\text{Eff}_{\text{base}} - 1/\text{Eff}_{\text{ee}}))}{100,000} \right] \end{aligned}$$

Where:

- MFHH = number of people in multifamily household  
= Actual. If unknown assume 2.1 persons/unit<sup>492</sup>
- #Units = Number of units served by hot water boiler  
= Actual
- GPD = Gallons of hot water used per person per day  
= Actual. If unknown assume 17.6 gallons per person per day<sup>493</sup>
- Days/yr = 365.25
- $\gamma_{\text{Water}}$  = Specific Weight of Water  
= 8.33 gal/lb
- $T_{\text{out}}$  = tank temperature of hot water  
= 125°F or custom

<sup>491</sup> The two equations are provided to show how savings are determined during the initial phase of the measure (existing to efficient) and the remaining phase (new baseline to efficient). In practice, the screening tools used may either require a First Year savings (using the first equation) and then a “number of years to adjustment” and “savings adjustment” input which would be the (new base to efficient savings)/(existing to efficient savings).

<sup>492</sup> Navigant, ComEd PY3 Multi-Family Home Energy Savings Program Evaluation Report Final, May 16, 2012.

<sup>493</sup> Deoreo, B., and P. Mayer. Residential End Uses of Water Study Update. Forthcoming. ©2015 Water Research Foundation. Reprinted With Permission.

$T_{in}$	= Incoming water temperature from well or municiple system = 50.7°F <sup>494</sup>				
$Eff_{base}$	= thermal efficiency of base unit = 80% <sup>495</sup>				
$Eff_{ee}$	= thermal efficiency of efficient unit complying with this measure = Actual. If unknown assume 88%				
$Eff_{exist}$	= thermal efficiency of existing unit = Actual. If unknown assume 73% <sup>496</sup>				
SL	= Standby Loss <sup>497</sup> = (Input rating / 800) + (110 * $\sqrt{\text{Tank Volume}}$ ). <table style="margin-left: 40px;"> <tr> <td>Input rating</td> <td>= Name plate input capacity in btuh</td> </tr> <tr> <td>Tank Volume</td> <td>= Rated volume of the tank in gallons</td> </tr> </table>	Input rating	= Name plate input capacity in btuh	Tank Volume	= Rated volume of the tank in gallons
Input rating	= Name plate input capacity in btuh				
Tank Volume	= Rated volume of the tank in gallons				
Hours/yr	= 8766 hours				
100,000	= btu/therm				

---

<sup>494</sup> Table 4 in Chen, et. al., “Calculating Average Hot Water Mixes of Residential Plumbing Fixtures”, June 2020, reports a value of 50.7°F for inlet water temperature for U.S. Census Division 3.

<sup>495</sup> IECC 2021, Table C404.2, Minimum Performance of Water-Heating Equipment, hot water supply boiler, gas.

<sup>496</sup> Based upon DCEO data provided 10/2014; average age adjusted efficiency of existing units replaced through the program. Efficiency age adjustment of 0.5% per year based upon NREL “Building America Performance Analysis Procedures for Existing Homes”.

<sup>497</sup> Stand-by loss is provided in IECC 2012/2015/2018, Table C404.2, Minimum Performance of Water-Heating Equipment.

**Time of Sale:**

**For example**, an 88% 1000-gallon boiler with 150,000 btuh input rating installed serving 50 units.

$$\begin{aligned} \Delta\text{Therms} &= \text{Hot Water Savings} + \text{Standby Loss Savings} \\ &= [(MFHH * \#Units * GPD * Days/yr * \gamma_{\text{Water}} * (T_{\text{out}} - T_{\text{in}}) * (1/\text{Eff}_{\text{base}} - 1/\text{Eff}_{\text{ee}})) / 100,000] \\ &\quad + [(SL * Hours/yr * (1/\text{Eff}_{\text{base}} - 1/\text{Eff}_{\text{ee}})) / 100,000] \\ &= [(2.1 * 50 * 17.6 * 8.33 * 365.25 * 1.0 * (125-50.7) * (1/0.8 - 1/0.88)) / 100,000] + \\ &\quad [((150,000/800 + (110 * \sqrt{1000}) * 8766 * (1/0.8 - 1/0.88)) / 100,000)] \\ &= 475 + 37 \\ &= 512 \text{ therms} \end{aligned}$$

**Early Replacement:**

**For example**, an 88% 1000-gallon boiler with 150,000 btuh input rating installed serving 50 units replaces a working unit with unknown efficiency.

$$\begin{aligned} \Delta\text{Therms for remaining life of existing unit first 5 years):} \\ &= [(2.1 * 50 * 17.6 * 8.33 * 365.25 * 1.0 * (125-50.7) * (1/0.73 - 1/0.88)) / 100,000] + \\ &\quad [((150,000/800 + (110 * \sqrt{1000}) * 8766 * (1/0.73 - 1/0.88)) / 100,000)] \\ &= 975 + 75 \\ &= 1050 \text{ therms} \end{aligned}$$

$$\begin{aligned} \Delta\text{Therms for remaining measure life (next 10 years):} \\ &= 475 + 37 \text{ (as above)} \\ &= 512 \text{ therms} \end{aligned}$$

**WATER IMPACT DESCRIPTIONS AND CALCULATION**

N/A

**DEEMED O&M COST ADJUSTMENT CALCULATION**

N/A

**MEASURE CODE: CI-HWE-MDHW-V07-240101**

**REVIEW DEADLINE: 1/1/2025**



## 4.3.8 Controls for Central Domestic Hot Water

### DESCRIPTION

Demand control recirculation pumps seek to reduce inefficiency by combining control via temperature and demand inputs, whereby the controller will not activate the recirculation pump unless both (a) the recirculation loop return water has dropped below a prescribed temperature (e.g., 100°F) and (b) a CDHW demand is sensed as water flow through the CDHW system.

This measure was developed to be applicable to the following program types: TOS, RF, NC. If applied to other program types, the measure savings should be verified.

### DEFINITION OF EFFICIENT EQUIPMENT

There are three efficient technologies to be considered:

- Timer-based: allows the user to program a schedule to perform recirculation during specific windows throughout the day.
- Aquastat-controlled: calls for recirculation when the water temperature at one point in the system falls below a certain pre-programmed setpoint (e.g., 100°F).
- On-Demand: senses the demand as water flow through the CDHW system. These types of system are most adequate on small central water heating systems.

### DEFINITION OF BASELINE EQUIPMENT

The baseline for this measure category is existing, uncontrolled recirculation pumps on gas-fired CDHW system.

### DEEMED LIFETIME OF EFFICIENT EQUIPMENT

The effective useful life is 15 years.<sup>498</sup>

### DEEMED MEASURE COST

The average cost of the demand controller circulation kit is \$1,442 with an installation cost of \$768 for a total measure cost of \$2,210.<sup>499</sup>

### LOADSHAPE

Loadshape C02 - Non-Residential Electric DHW

### COINCIDENCE FACTOR

N/A

---

<sup>498</sup> Benningfield Group. (2009). *PY 2009 Monitoring Report: Demand Control for Multifamily Central Domestic Hot Water*. Folsom, CA: Prepared for Southern California Gas Company, October 30, 2009.

<sup>499</sup> The incremental costs were averaged based on the following multi-family, dormitory and hospitality building studies-Gas Technology Institute. (2014). *1003: Demand-based domestic hot water recirculation Public project report*. Des Plaines, IL: Prepared for Nicor Gas, January 7, 2014.

Studies performed in multiple dormitory buildings in the California region for Southern California Gas' PREPS Program, 2012. Evaluation of New DHW System Controls in Hospitality and Commercial Buildings. Prepared for: Minnesota Department of Commerce, Division of Energy Resources, 2018.

**Algorithm**

**CALCULATION OF ENERGY SAVINGS**

**ELECTRIC ENERGY SAVINGS**

$$\Delta kWh = \Delta kWh_{heater} + \Delta kWh_{pump}$$

$$\Delta kWh_{heater} = \%ElecDHW * Boiler Capacity * (t_{normal\ occ} * R_{normal\ occ} + t_{low\ occ} * R_{low\ occ}) / 3,412$$

$$\Delta kWh_{pump} = (HP_{recirc} * 0.746 * (8760 - Pump_{hrs\ controlled}) / Motor_{eff}$$

$$\Delta kWh_{pump} = 1,103^{500} \text{ kWh as default value if values unknown.}$$

Where:

**%ElecDHW** = proportion of water heating supplied by electric resistance heating  
 = 1 if electric DHW; 0 if fuel DHW. If unknown, assume 27.6%.<sup>501</sup>

**Boiler Capacity** = Input Capacity of the Domestic Hot Water boiler in BTU/hr  
 = If the facility uses the same boiler for space heat and domestic hot water, estimate the boiler input capacity for only domestic hot water loads. If this cannot be estimated, use the table below:

Building Type	% of Boiler Input Capacity	Or Use the Following Formulas
Multifamily	22.75% <sup>502</sup>	= 12,493 BTU/hr * (#Apartments) <sup>503</sup>
Dormitories	16.48% <sup>504</sup>	= 4,938 BTU/hr * (#Rooms) <sup>505</sup>
Hotels/Motels	12.33% <sup>506</sup>	= 3,696 BTU/hr * (#Rooms) <sup>507</sup>
Offices	Use Actual Size	Use Actual Size

<sup>500</sup> This value is the average kWh saved per pump based on results from Multi-Family buildings studied in Nicor Gas Emerging Technology Program study, Southern California Gas’ study in multiple dormitory buildings, and Minnesota’s Evaluation of New DHW System Controls in Hospitality and Commercial Buildings. Note this value does not reflect savings from electric units but electrical savings from gas-fired units. See ‘CDHW Controls Summary Calculations.xlsx’ for more information.

<sup>501</sup> Based on Applied Energy Group, 2016 ‘Ameren Illinois Demand Side Management Market Potential Study: Volume 4 – APPENDICES’.

<sup>502</sup> This is an average number based on Residential Energy Consumption Survey (2009) data and Commercial Building Energy Consumption Survey (2012) data compiled by U.S. Energy Information Administration, for buildings with more than 5 apartments in Illinois and Nursing Home and Assisted Living facilities in Midwest.

<sup>503</sup> This is based on studies done in multiple university dormitory buildings in the California region, for Southern California Gas’ PREPS Program, 2012. It closely matches the design guidelines outlined in 2007 ASHRAE Handbook, Chapter 49: Service Water Heating, Table 7, and assumes 1 to 2 students per dorm room based on typical dorm room layouts. This source provides the source for dormitory assumptions of Boiler Input Capacity,  $t_{low\ occ}$ ,  $R_{normal\ occ}$  and  $R_{low\ occ}$ .

<sup>504</sup> This is based on Commercial Building Energy Consumption Survey (2012) data compiled by U.S. Energy Information Administration, for Education facilities in East North Central.

<sup>505</sup> This is based on studies done at Multi-Family Buildings for the Nicor Gas Emerging Technology Program by Gas Technology Institute. It closely matches the design guidelines outlined in 2007 ASHRAE Handbook, Chapter 49: Service Water Heating, Table 9, and assumes 2.1 persons per apartment as per ComEd PY3 Multi-Family Home Energy Savings Program Evaluation Report Final, May 16, 2012, by Navigant. This source provides the source for dormitory assumptions of Boiler Input Capacity,  $t_{low\ occ}$ ,  $R_{normal\ occ}$  and  $R_{low\ occ}$ .

<sup>506</sup> This value is ratioed upon the Btu per Dwelling per Hotel/Motel vs Dormitory building type assuming the same heating capacity requirements based upon the similarity between the building types.

<sup>507</sup> Calculated based upon ASHRAE 2015 ASHRAE HVAC Applications Table 6 and IL TRM assumptions. See ‘CDHW Controls Summary Calculations.xlsx’ for more information

$HP_{recirculating}$  = the size of the recirculating pump in HP

0.746 = Conversion factor kW/HP

8760 = Hours of operation of uncontrolled recirculating pump

$Pump_{hrs\ controlled}$  = The table below corresponds to the control types for commercial buildings

Hours of Operation <sup>508</sup>	
Timer	6,570
Aquastat-Controlled	1,095
On Demand	122

$Motor_{eff}$  = The efficiency of the pump motor. Use actual or, if unknown, use the table below:

Motor HP	Efficiency
0.25	66.7%
0.33	70.6%
0.5	75.3%
0.75	79.6%
1.0	81.2%
1.5	84.8%
2.0	85.8%
3.0	87.2%

**SUMMER COINCIDENT PEAK DEMAND SAVINGS**

N/A

**FOSSIL FUEL SAVINGS**

Gas savings for this measure can be calculated by using site specific boiler size and boiler usage information or deemed values are provided based on number of rooms for Dormitories and number of apartments for multifamily buildings.<sup>510</sup>

$$\Delta Therms = \%FossilDHW * Boiler\ Input\ Capacity * (t_{normal\ occ} * R_{normal\ occ} + t_{low\ occ} * R_{low\ occ}) / 100,000$$

Where:

$\%FossilDHW$  = proportion of water heating supplied by fossil fuel heating.  
 = 0 if electric DHW; 1 if fuel DHW. If unknown, assume 72.4%<sup>511</sup>.

**Boiler Input Capacity** = Input capacity of the Domestic Hot Water boiler in BTU/hr.  
 = If the facility uses the same boiler for space heat and domestic hot water, estimate the boiler input capacity for only domestic hot water loads. If this cannot be estimated, use the following table:

<sup>508</sup> The Hours of operation of recirculating pump for commercial buildings in general from Research and Analysis of the Benefits of Appliance Standards for Domestic Hot Water Circulator Pumps. Energy Solutions (October 2021)

<sup>509</sup> Blended efficiencies for small motors IECC 2021, Table C405.8(2), Table C405.8(3) and Table C405.8(3)

<sup>510</sup> See 'CDHW Controls Summary Calculations.xlsx' for more information.

<sup>511</sup> Table HC8.9. Water Heating in U.S. Homes in Midwest Region, Divisions, and States, 2009 (RECS).

Building Type	% of Boiler Input Capacity	Or Use the Following Formulas
Multifamily	22.75% <sup>512</sup>	= 12,493 BTU/hr * (#Apartments) <sup>513</sup>
Dormitories	16.48% <sup>514</sup>	= 4,938 BTU/hr * (#Rooms) <sup>515</sup>
Hotels/Motels	12.33% <sup>516</sup>	= 3,696 BTU/hr * (#Rooms) <sup>517</sup>
Offices	Use Actual Size	Use Actual Size

- $t_{normal\ occ}$  = Total operating hours of domestic hot water burner when the facility has normal occupancy. If unknown, use the following table.
- $t_{low\ occ}$  = Total operating hours of domestic hot water burner, when the facility has low occupancy. <sup>518</sup> If unknown, use the following table.
- $R_{normal\ occ}$  = Reduction(%) in total operating hours of domestic hot water burner, due to installed central domestic hot water controls, during normal occupancy period. Values are set in the table below.
- $R_{low\ occ}$  = Reduction(%) in total operating hours of domestic hot water burner, due to installed central domestic hot water controls, during low occupancy period. Values are set in the table below.

<sup>512</sup> This is an average number based on Residential Energy Consumption Survey (2009) data and Commercial Building Energy Consumption Survey (2012) data compiled by U.S. Energy Information Administration, for buildings with more than 5 apartments in Illinois and Nursing Home and Assisted Living facilities in Midwest.

<sup>513</sup> This is based on studies done in multiple university dormitory buildings in the California region, for Southern California Gas' PREPS Program, 2012. It closely matches the design guidelines outlined in 2007 ASHRAE Handbook, Chapter 49: Service Water Heating, Table 7, and assumes 1 to 2 students per dorm room based on typical dorm room layouts. This source provides the source for dormitory assumptions of Boiler Input Capacity,  $t_{low\ occ}$ ,  $R_{normal\ occ}$  and  $R_{low\ occ}$ .

<sup>514</sup> This is based on Commercial Building Energy Consumption Survey (2012) data compiled by U.S. Energy Information Administration, for Education facilities in East North Central.

<sup>515</sup> This is based on studies done at Multi-Family Buildings for the Nicor Gas Emerging Technology Program by Gas Technology Institute. It closely matches the design guidelines outlined in 2007 ASHRAE Handbook, Chapter 49: Service Water Heating, Table 9, and assumes 2.1 persons per apartment as per ComEd PY3 Multi-Family Home Energy Savings Program Evaluation Report Final, May 16, 2012 by Navigant. This source provides the source for dormitory assumptions of Boiler Input Capacity,  $t_{low\ occ}$ ,  $R_{normal\ occ}$  and  $R_{low\ occ}$ .

<sup>516</sup> This value is ratioed upon the Btu per Dwelling per Hotel/Motel vs Dormitory building type assuming the same heating capacity requirements based upon the similarity between the building types.

<sup>517</sup> Calculated based upon ASHRAE 2015 ASHRAE HVAC Applications Table 6 and IL TRM assumptions. See 'CDHW Controls Summary Calculations.xlsx' for more information

<sup>518</sup> Low occupancy periods for dormitory buildings can be assumed as vacation day or holiday occupancy.

Building Type	t <sub>normal occ</sub> (hours)	t <sub>low occ</sub> (hours)	R <sub>normal occ</sub> (%)	R <sub>low occ</sub> (%)
Multi-Family	2,089 <sup>519</sup>	0	24.02%	0%
Dormitories	1,688 <sup>520</sup>	520 <sup>521</sup>	22.44%	44.57% <sup>522</sup>
Hotels/Motels	2,428 <sup>523</sup>	0	13.44% <sup>524</sup>	0%
Offices	2,857 <sup>525</sup>	1,231	22.90%	41.70%

Based on defaults above:

$$\begin{aligned} \Delta\text{Therms} &= 30.1 * \text{number of rooms (for dormitories)} \\ &= 62.7 * \text{number of apartments (for multifamily buildings)} \\ &= 12.06 * \text{number of rooms (hotels/motels)} \end{aligned}$$

**For example**, a dormitory building has a 400,000 BTU/hr boiler whose burner operates for an estimated 580 hours during vacation months and 1,300 hours during regular occupancy months. Savings from installing central domestic hot water controls in this building are:

$$\begin{aligned} \Delta\text{Therms} &= 400,000 \text{ BTU/hr} * (1,300 * 0.2244 + 580 * 0.4457) / 100,000 \\ &= 2,201 \text{ therms} \end{aligned}$$

**WATER IMPACT DESCRIPTIONS AND CALCULATION**

N/A

**DEEMED O&M COST ADJUSTMENT CALCULATION**

N/A

**MEASURE CODE: CI-HWE-CDHW-V06-240101**

**REVIEW DEADLINE: 1/1/2027**

<sup>519</sup> Based on results of the studies done at Multi-Family Buildings for the Nicor Gas Emerging Technology Program: Gas Technology Institute. (2014). *1003: Demand-based domestic hot water recirculation Public project report*. Des Plaines, IL: Prepared for Nicor Gas, January 7, 2014.

<sup>520</sup> Based on results of studies performed in multiple university dormitory buildings in the California region, for Southern California Gas’ PREPS Program, 2012.

<sup>521</sup> Low occupancy periods for dormitory buildings can be assumed as vacation day or holiday occupancy.

<sup>522</sup> Estimated from low occupancy hours

<sup>523</sup> Calculated from the Btu per dwelling unit and average annual therm consumption for DHW for all Hospitality Buildings noted in “Evaluation of New DHW System Controls in Hospitality and Commercial Buildings”, MN Commerce Department Energy Resources, 06/30/2018.

<sup>524</sup> Average Hospitality Savings, “Evaluation of New DHW System Controls in Hospitality and Commercial Buildings”, MN Commerce Department Energy Resources, 06/30/2018.

<sup>525</sup> Based on the report, Energy Efficiency with Domestic Water Heating in Commercial Buildings, ACEEE Summer Study on Energy Efficiency in Buildings, 2010. Using the tables of results for Tuesday, Saturday and Sunday to estimate blended values for t<sub>normal occ</sub>, t<sub>low occ</sub>, R<sub>normal occ</sub> and R<sub>low occ</sub>.

### 4.3.9 Heat Recovery Grease Trap Filter

**DESCRIPTION**

A heat recovery grease trap filter combines grease filters and a heat exchanger to recover heat leaving kitchen hoods. As a direct replacement for conventional hood mounted filters in commercial kitchens, they are plumbed to the domestic hot water system to provide preheating energy to incoming water.

This measure was developed to be applicable to the following program types: NC and RF. If applied to other program types, the measure savings should be verified. For NC projects, this measure may be applicable if code requirements are otherwise satisfied.

**DEFINITION OF EFFICIENT EQUIPMENT**

Grease filters with heat exchangers carrying domestic hot water in kitchen exhaust air ducts.

**DEFINITION OF BASELINE EQUIPMENT**

Kitchen exhaust air duct with constant air flow and no heat recovery.<sup>526</sup>

**DEEMED LIFETIME OF EFFICIENT EQUIPMENT**

The expected measure life is assumed to be 15 years.<sup>527</sup>

**DEEMED MEASURE COST**

Full installation costs, including plumbing materials, labor and any associated controls, should be used for screening purposes.

**LOADSHAPE**

Loadshape C01 - Commercial Electric Cooking

**COINCIDENCE FACTOR**

Summer Peak Coincidence Factor for measure is provided below for different building type:<sup>528</sup>

Location	CF
Fast Food Limited Menu	0.32
Fast Food Expanded Menu	0.41
Pizza	0.46
Full Service Limited Menu	0.51
Full Service Expanded Menu	0.36
Cafeteria	0.36
Unknown	0.40

<sup>526</sup> Savings methodology factors are for a constant speed fan.

<sup>527</sup> Professional judgement, consistent with expected lifetime of kitchen demand ventilation controls and other kitchen equipment.

<sup>528</sup> Minnesota 2012 Technical Reference Manual, Electric Food Service\_v03.2.xls

**Algorithm**

**CALCULATION OF ENERGY SAVINGS**

**ELECTRIC ENERGY SAVINGS**

For electric hot water heaters:

$$\Delta kWh = \frac{[(Meal/Day * HW/Meal * Days/Year) * lbs/gal * BTU/lb.^{\circ}F * (\Delta T/filter * Qty\_Filter) * 0.000293]}{(\eta_{HeaterElec})}$$

Where:

- Meal/Day = Average number of meals served per day. If not directly available, see Table 1.
- HW/Meal = Hot water required per meal  
= 3 gal/meal<sup>529</sup>
- Days/Year = Number of days kitchen operates per year. If not directly available, see Table 1.
- Lbs/gal = Density of water  
= 8.3 lbs/gal
- BTU/lb.°F = Specific heat of water  
= 1.0
- ΔT/filter = Temperature difference of domestic water across each filter  
= 5.8°F/filter<sup>530</sup>
- Qty\_Filter = Number of heat recovery grease trap filters installed. If not directly available, see Table 1.

**Commercial Kitchen Load based on Building Type**

Building Type	Meals/Day <sup>531</sup>	Assumed days/Year	Number of Filters <sup>532</sup>
Primary School	400	312	2
Secondary School	600	312	3
Quick Service Restaurant	800	312	5
Full Service Restaurant	780	312	4
Large Hotel	780	356	4
Hospital	800	356	4

$\eta_{HeaterElec}$  = Efficiency of the Electric water heater.

<sup>529</sup> Average dishwashing and faucet water usage taken from Chapter 8, Table 8.3.3 Normalized Annual End Uses of Water in Select Restaurants in Western United States.

<sup>530</sup> Average value based on case studies. Northwinds Sailing, Inc. and North Shore Sustainable Energy, LLC. *Angry Trout Café Kitchen Exhaust Heat Recovery*. Minnesota Department of Commerce, Division of Energy Resources, 2012.

<sup>531</sup> Commercial Kitchen Loads for listed buildings in U.S. Department of Energy Commercial Reference Building Models of the National Building Stock, NREL

<sup>532</sup> Each filter is 20 X 20 inches.

= Actual. If unknown, for retrofit use the table C404.2 in IECC 2012. For new construction use the active code at time the permit was issued.

**SUMMER COINCIDENT PEAK DEMAND SAVINGS**

$$\Delta kW = \Delta kWh/Hours * CF$$

Where:

Hours = Hours of operation of kitchen exhaust air fan. If not directly available use:

Building Type	Kitchen Exhaust Fan Annual Operating Hours <sup>533</sup>
Primary School	4,056
Secondary School	4,056
Quick Service Restaurant	5,616
Full Service Restaurant	5,616
Large Hotel	5,340
Hospital	3,916

CF = Summer Peak Coincidence Factor for measure:<sup>534</sup>

Location	CF
Fast Food Limited Menu	0.32
Fast Food Expanded Menu	0.41
Pizza	0.46
Full Service Limited Menu	0.51
Full Service Expanded Menu	0.36
Cafeteria	0.36
Unknown	0.40

**FOSSIL FUEL SAVINGS**

For natural gas hot water heaters:

$$\Delta Therm = [(Meal/Day * HW/Meal * Days/Year) * lbs/gal * BTU/lb .°F * (\Delta T/filter * Qty_Filter)] / (\eta_{HeaterGas} * 100,000)$$

Where:

$\eta_{HeaterGas}$  = Efficiency of the Gas water heater. If not directly available, use:  
 = Actual. If unknown, for retrofit use the table C404.2 in IECC 2012. For new construction use the active code at time the permit was issued.

Other variables as above.

<sup>533</sup> Exhaust Fan Schedules for listed buildings in U.S. Department of Energy Commercial Reference Building Models of the National Building Stock, NREL.

<sup>534</sup>Minnesota 2012 Technical Reference Manual, Electric Food Service\_v03.2.xls.



**WATER AND OTHER NON-ENERGY IMPACT DESCRIPTIONS AND CALCULATION**

N/A

**DEEMED O&M COST ADJUSTMENT CALCULATION**

O&M savings may result from reduced filter and hood cleaning frequencies. More research should be done to understand any potential savings and the associated value.

**MEASURE CODE: CI-HWE-GRTF-V04-240101**

**REVIEW DEADLINE: 1/1/2027**

### 4.3.10 DHW Boiler Tune-up

#### DESCRIPTION

Domestic hot water (DHW) boilers provide hot water for bathrooms, kitchens, tubs and other appliances. Several commercial and industrial facilities such as multi-family buildings, lodging and restaurants have a separate hot water boiler serving DHW loads. Unlike space heating boilers, DHW boilers operate year round, which means they have a greater need to be properly maintained and tuned up.

This measure calculates savings for tuning up a DHW boiler to improve its efficiency and reduce its consumption. A boiler tune-up involves cleaning/inspecting burners, burner nozzles and combustion chambers, adjusting air flow and burner gas input to reduce stack temperatures, and checking venting and safety controls. A pre- and post-tune up combustion efficiency ticket (from combustion analyzer) can be used to confirm the improvement in boiler efficiency.

Boilers that serve only a DHW load are eligible for this measure.

This measure was developed to be applicable to the following program types: RF. If applied to other program types, the measure savings should be verified.

#### DEFINITION OF EFFICIENT EQUIPMENT

To qualify for this measure the facility must, as applicable, complete the tune-up requirements<sup>535</sup> listed below, by approved technician:

- Measure combustion efficiency using an electronic flue gas analyzer
- Adjust airflow and reduce excessive stack temperatures
- Adjust burner and gas input, manual or motorized draft control
- Check for proper venting
- Complete visual inspection of system piping and insulation
- Check safety controls
- Check adequacy of combustion air intake
- Clean fireside surfaces.
- Inspect all refractory. Patch and wash coat as required.
- Inspect gaskets on front and rear doors and replace as necessary.
- Seal and close front and rear doors properly.
- Clean low and auxiliary low water cut-off controls, then re-install using new gaskets.
- Clean plugs in control piping.
- Remove all hand hole and man hole plates. Flush boiler with water to remove loose scale and sediment.
- Replace all hand hole and man hole plates with new gaskets.
- Open feedwater tank manway, inspect and clean as required. Replace manway plate with new gasket.
- Clean burner and burner pilot.
- Check pilot electrode and adjust or replace.
- Clean air damper and blower assembly.
- Clean motor starter contacts and check operation.
- Make necessary adjustments to burner for proper combustion.
- Perform all flame safeguard and safety trip checks.

---

<sup>535</sup> Act on Energy Commercial Technical Reference Manual No. 2010-4, 9.2.2 Gas Boiler Tune-up.

- Check all hand hole plates and man hole plates for leaks at normal operating temperatures and pressures.
- Troubleshoot any boiler system problems as requested by on-site personnel

**DEFINITION OF BASELINE EQUIPMENT**

The baseline condition of this measure is a boiler that has not had a tune-up within the past 36 months.

**DEEMED LIFETIME OF EFFICIENT EQUIPMENT**

The life of this measure is 3 years.<sup>536</sup>

**DEEMED MEASURE COST**

The cost of this measure is \$0.83/MBtu/hr per tune-up.<sup>537</sup>

**LOADSHAPE**

N/A

**COINCIDENCE FACTOR**

N/A

---



---

**Algorithm**

---

**CALCULATION OF ENERGY SAVINGS**

**ELECTRIC ENERGY SAVINGS**

N/A

**SUMMER COINCIDENT PEAK DEMAND SAVINGS**

N/A

**FOSSIL FUEL SAVINGS**

$$\Delta\text{Therms} = ((T_{\text{out}} - T_{\text{in}}) * \text{HotWaterUse}_{\text{Gallon}} * \gamma_{\text{water}} * 1 * (1/\text{Eff}_{\text{before}} - 1/\text{Eff}_{\text{after}}))/100,000$$

Where:

- $T_{\text{OUT}}$  = Hot water storage tank temperature  
= 125°F
- $T_{\text{IN}}$  = Incoming water temperature from well or municipal system  
= 54°F<sup>538</sup>
- $\text{HotWaterUse}_{\text{Gallon}}$  = Estimated annual hot water consumption (gallons)  
= Actual if possible to provide reasonable custom estimate. If not, the following methods are provided to develop an estimate:<sup>539</sup>

---

<sup>536</sup> Act on Energy Commercial Technical Reference Manual No. 2010-4, 9.2.2 Gas Boiler Tune-up.

<sup>537</sup> Work Paper – Tune up for Boilers serving Space Heating and Process Load by Resource Solutions Group, January 2012

<sup>538</sup>US DOE Building America Program, Building America Analysis Spreadsheet (for Chicago, IL), Office of Energy Efficiency & Renewable Energy.

<sup>539</sup> Methodology based on Cadmus analysis. Annual hot water usage in gallons based on CBECS (2012) and RECS (2009) consumption data of East North Central (removed outliers of 1,000 kBtu/h or less) to calculate hot water usage. Annual hot

1. Consumption per usable storage tank capacity

$$= \text{Capacity} * \text{Consumption/cap}$$

Where:

Capacity = Usable capacity of hot water storage tank in gallons  
= Actual

Consumption/cap = Estimate of consumption per gallon of usable tank capacity, based on building type:

Building Type <sup>540</sup>	Consumption/Cap
Convenience	528
Education	568
Grocery	528
Health	788
Large Office	511
Large Retail	528
Lodging	715
Other Commercial	341
Restaurant	622
Small Office	511
Small Retail	528
Warehouse	341
Nursing	672
Multi-Family	894

2. Consumption per unit area by building type

$$= (\text{Area}/1000) * \text{Consumption}/1,000 \text{ sq.ft.}$$

Where:

Area = Area in sq.ft that is served by DHW boiler  
= Actual

Consumption/1,000 sq.ft. = Estimate of DHW consumption per 1,000 sq.ft. based on building type:

Building Type	Consumption/1,000 sq.ft.
Convenience	4,594
Education	7,285
Grocery	697
Health	24,540
Large Office	1,818
Large Retail	1,354
Lodging	29,548

water gallons per tank size gallons based on the tank sizing methodology found in ASHRAE 2011 HVAC Applications. Chapter 50 Service Water Heating. Demand assumptions (gallons per day) for each building type based on ASHRAE Chapter 50 and to LBNL White Paper. LBL-37398 Technology Data Characterizing Water Heating in Commercial Buildings: Application to End Use Forecasting. Assumes hot water heater efficiency of 80%.

<sup>540</sup> According to CBECS 2012 “Lodging” buildings include Dormitories, Hotels, Motel or Inns and other Lodging and “Nursing” buildings include Assisted Living and Nursing Homes.

Building Type	Consumption/1,000 sq.ft.
Other Commercial	3,941
Restaurant	44,439
Small Office	1,540
Small Retail	6,111
Warehouse	1,239
Nursing	30,503
Multi-Family	15,434

$\gamma_{\text{water}}$  = Specific weight capacity of water (lb/gal)

= 8.33 lbs/gal

1 = Specific heat of water (Btu/lb.°F)

$\text{Eff}_{\text{before}}$  = Efficiency of the boiler before tune-up

$\text{Eff}_{\text{after}}$  = Efficiency of the boiler after tune-up

100,000 = Converts Btu to therms

*Note: Contractors should select a mid-level firing rate that appropriately represents the average building operating condition over the course of the year and take readings at a consistent firing rate for pre and post tune-up.*

**For example**, tune up of a DHW Boiler heating a 100 gallon storage tank in a nursing home, measuring 80% AFUE prior to tune up and 82.2% AFUE after.

$$\begin{aligned} \Delta\text{Therms} &= ((T_{\text{out}} - T_{\text{in}}) * \text{HotWaterUse}_{\text{Gallon}} * \gamma_{\text{water}} * 1 * (1/\text{Eff}_{\text{before}} - 1/\text{Eff}_{\text{after}}))/100,000 \\ &= ((125 - 54) * (100 * 672) * 8.33 * 1 * (1/0.8 - 1/0.822))/100,000 \\ &= 13.3 \text{ therms} \end{aligned}$$

**WATER AND OTHER NON-ENERGY IMPACT DESCRIPTIONS AND CALCULATION**

N/A

**DEEMED O&M COST ADJUSTMENT CALCULATION**

N/A

**MEASURE CODE: CI-HWE-DBTU-V02-240101**

**REVIEW DEADLINE: 1/1/2029**

### 4.3.11 Tunnel Washers

#### **DESCRIPTION**

Laundry equipment can be found at a variety of facilities, including hospitals, hotels, health clubs, penitentiaries, and others. Typically, these facilities use conventional batch washing machines for laundering their linens, towels, napkins and tablecloths, and uniforms. The uniformity of the feedstocks makes them good candidates for conversion to a continuous-batch tunnel washing machine system, which ultimately utilizes less water and detergent than conventional systems. The water savings are ultimately based on a comparison of the water efficiencies between the baseline and efficient equipment (measured in gallons of water per pound of laundry).

#### **DEFINITION OF EFFICIENT EQUIPMENT**

A tunnel washing machine utilizes a porous Archimedes screw to move laundry and wash water in opposite (or counterflow) directions. The laundry travels in the upslope direction, while the wash water travels downslope through the holes in the Archimedes screw. The laundry gets progressively cleaner as it travels up the screw, while the wash water gets progressively dirtier as it travels down the screw. The screw can be programmed to intermittently change direction, to provide additional agitation. The mechanical action of the screw and travel path of the wash water through holes helps significantly with the cleaning action of the tunnel washer, allowing a reduction in the amount of detergent and rinse water required.

In contrast to the baseline equipment, the tunnel washer reuses the “rinse” water from the top section of the tunnel into the lower “wash” water sections, along with the gradual introduction of detergent. The continuous counterflow of laundry and wash water ultimately results in a more water-efficient system.

Tunnel washers also utilize automated PLC computer controls to constantly monitor water temperatures in each section of the tunnel and to automate the introduction of fresh water and detergent. The speed of the Archimedes screw can adjust for the varying dirt load of the laundry input. The computer system can typically collect performance data (gallons of water, pounds of detergent, pounds of laundry) over time to continuously evaluate system efficiency.

Tunnel washers can utilize either a hydraulic press extractor to “squeeze” water out of the linen or a more conventional centrifugal extractor that spins the linen to remove the water.

Tunnel washers can also reduce manhours required to process the laundry, as a staff is not required to manually load and unload each batch. The continuous feed of laundry in a tunnel washing machine system requires less labor and reduces the potential for injury from sticking hand and arms into a conventional washing machine drum.

Tunnel washers are quite large compared to conventional washers and require a significant footprint in the facility. In addition, they require approximately 12 feet of ceiling clearance above the top of the tunnel washer for proper installation.

#### **DEFINITION OF BASELINE EQUIPMENT**

A traditional batch washing machine has discrete washing and rinsing cycles, wherein the water gets completely drained at the end of each cycle.

Typical top-loading washing machines used in homes and laundromats use approximately 40 gallons of water per load. This equates to 20 gallons for the wash cycle and 20 gallons for the rinse cycle. Some facilities will even utilize a second rinse cycle. The vertical axis design requires enough water in the drum to suspend the fabric in the soapy water.

The next step up in efficiency is a front-loading (or horizontal axis) washing machines. They typically use 20 to 30 gallons of water per load. This equates to 10-15 gallons for the wash cycle and 10-15 gallons for the rinse cycle.

Larger horizontal-axis washing machines can consume up to 45 gallons of water per load, equating to 22 gallons for the wash cycle and 22 gallons for the rinse cycle.

**DEEMED LIFETIME OF EFFICIENT EQUIPMENT**

The life of this measure is assumed to be 15 years for a new tunnel washing machine.<sup>541</sup>

**DEEMED MEASURE COST**

The actual cost of the measure should be used.<sup>542</sup>

**LOADSHAPE**

N/A

**COINCIDENCE FACTOR**

N/A

**Algorithm**

**CALCULATION OF ENERGY SAVINGS**

Energy savings from conversion from conventional washing machines to tunnel washing machines are the result of reduced water consumption and reduced natural gas consumption from heating water. There are indirect electric energy savings from reduced potable water treatment and wastewater treatment.

**ELECTRIC ENERGY SAVINGS**

The electric energy savings are based indirectly on the reduced electricity usage attributed to the water savings from the tunnel washing machine. By applying an “Energy Factor”, the water savings (in gallons/year) can be converted to electricity savings (in kWh/year). This “Energy Factor” considers the electric energy requirements of water treatment plants and water distribution infrastructure, and wastewater treatment and distribution infrastructure.

The methodology for estimating water savings is as follows:

$$\Delta\text{Water} = [\text{BWME} - \text{TWME}] \times \text{PLD} \times \text{ADPY}$$

$\Delta\text{Water} =$  Total Water Savings (gallons/year)

$\text{BWME} =$  Baseline Washing Machine Efficiency (gal of water / lb. of laundry)

$\text{TWME} =$  Tunnel Washing Machine Efficiency (gal of water / lb. of laundry)

$\text{PLD} =$  Pounds of Laundry Per Day (lb. laundry/day)

$\text{ADPY} =$  Annual Days Per Year (days/year)

The values for BWME and TWME should be taken from actual equipment specifications or actual measurements (water flow meters and mechanical scales).

Typical values for TWME can be range from 0.75-1.0 gal. of water/lb. of laundry.<sup>543</sup> Some equipment vendors have claimed TWME approaching 0.3-0.4 gal. of water/lb. of laundry.<sup>544</sup> For the purposes of this measure, a TWME value of 0.87 gal. of water/lb. of laundry will be used.

<sup>541</sup> Table 8-18: Average Useful Lifetime of Commercial Washing Equipment, Energy Savings Potential and RD&D Opportunities for Commercial Building Appliances, Navigant Consulting, December 21, 2009.

<sup>542</sup> One study found the average cost of tunnel washers to be \$1,100,000. Energy Savings Potential and RD&D Opportunities for Commercial Building Appliances, Navigant Consulting, December 21, 2009.

[https://www1.eere.energy.gov/buildings/publications/pdfs/corporate/commercial\\_appliances\\_report\\_12-09.pdf](https://www1.eere.energy.gov/buildings/publications/pdfs/corporate/commercial_appliances_report_12-09.pdf)

<sup>543</sup> Matt Poe. “Efficient, Flexible Tunnel Washers: Tunnel washers have made leaps forward in technology, productivity in the past 10 years”, *American Laundry News*, 12/11/18. <<https://americanlaundrynews.com/articles/efficient-flexible-tunnel-washers>>

<sup>544</sup> Ibid.

Typical values for BWME can range from 1.8-3.0 gal. of water/lb. of laundry.<sup>545</sup> For the purposes of this measure, a BWME value of 2.03 gal. of water/lb. of laundry will be used.<sup>546</sup>

The PLD is specific to each individual facility. An occupied hotel room typically produces 11 pounds of laundry per day.<sup>547</sup> An occupied hospital bed likely produces a similar amount of laundry load. The laundry loads of restaurants, health clubs, prisons, and other facilities need to be quantified using actual facility data.

The PLD can also be estimated from the Ozone Laundry Measure in the IL TRM, section 4.3.6. This measure gives a Washer Utilization Factor (Wutil) of 916,150 pounds/year of laundry for a typical facility.<sup>548</sup> Assuming 365 days/year of laundry activity, this would give a PLD of 2,508 pounds of laundry per day.

The ADPY is often 365 days per year for facilities that never shut down, including hospitals, hotels, and prisons. Other facilities may have regular shutdown periods, so the ADPY value should be adjusted as necessary.

The electricity savings for this measure can be calculated by applying the energy factor to the ΔWater. This EF considers savings from both potable water treatment and wastewater treatment.

$$\Delta kWh_{water} = \Delta Water \text{ (gallons)} / 1,000,000 * E_{water \text{ total}}$$

Where

$$\begin{aligned} E_{water \text{ total}} &= \text{IL Total Water Energy Factor (kWh/Million Gallons)} \\ &= 5,010^{549} \end{aligned}$$

**For example**, switching from conventional washing machine technology to tunnel washing machine technology, at a facility that processes the defined 916,150 pounds/year (Wutil) and is open every day of the year.

$$\begin{aligned} \Delta Water &= [BWME - TWME] \times PLD \times ADPY \\ &= [(2.03 - 0.87) \text{ gal. of water/lb. of laundry}] \times (916,150 \text{ lb. of laundry/year}) \\ &= 1,062,734 \text{ gal. of water/year} \end{aligned}$$

$$\begin{aligned} \Delta kWh_{water} &= \Delta Water / 1,000,000 * E_{water \text{ total}} \\ &= (1,062,734 \text{ gal. of water/year}) / 1,000,000 * 5,010 \text{ kWh/million gallons} \\ &= 5,324 \text{ kWh/year} \end{aligned}$$

### SUMMER COINCIDENT PEAK DEMAND SAVINGS

Since the times of day from the water savings measure do not necessarily coincide with the times of day that the water treatment and distribution equipment is in use, the coincident peak demand savings cannot be determined.

### FOSSIL FUEL SAVINGS

With reduced water use by the installation of a tunnel washer, the DHW boiler used to heat the incoming water will use significantly less gas. The below algorithm can be used to calculate natural gas savings for hot water heating.

<sup>545</sup> Theresa Boehl. "Tunnel Washers: The Answer to Rising Labor, Utility Costs?", *American Laundry News*, 5/27/14.

<<https://americanlaundrynews.com/articles/tunnel-washers>>

<sup>546</sup> IL TRM Section 4.3.6 "Ozone Laundry"

<sup>547</sup> Joseph Ricci. "Outsourced Hotel Laundries: The Value of Certification", *Lodging*, 3/28/17.

<<https://lodgingmagazine.com/outsourced-hotel-laundries-the-value-of-certification/>>

<sup>548</sup> IL TRM Section 4.3.6 footnote for  $W_{util}$ , which states "Average utilization factors were generated using data collected from existing ozone laundry projects that received incentives under the NRR-DR program."

<sup>549</sup> This factor include 2571 kWh/MG for water supply based on Illinois energy intensity data from a 2012 ISAWWA study and 2439 kWh/MG for wastewater treatment based on national energy intensity use estimates. For more information please review Elevate Energy's 'IL TRM: Energy per Gallon Factor, May 2018 paper'.



$$\Delta\text{Therms} = ((T_{\text{out}} - T_{\text{in}}) * \text{HotWaterReduction}_{\text{Gallon}} * \gamma_{\text{water}} * 1 * (1/\text{Eff}))/100,000$$

Where:

$T_{\text{OUT}}$	= Hot water storage tank temperature = 125°F
$T_{\text{IN}}$	= Incoming water temperature from well or municipal system = 54°F <sup>550</sup>
$\text{HotWaterReduction}_{\text{Gallon}}$	= Estimated annual hot water reduction (gallons) = Actual custom estimate
$\gamma_{\text{water}}$	= Specific weight capacity of water (lb/gal) = 8.33 lbs/gal
1	= Specific heat of water (Btu/lb.°F)
Eff	= Efficiency of the boiler = Use actual efficiency, otherwise use 80% AFUE
100,000	= Converts Btu to therms

**For example**, a DHW Boiler with an efficiency of 80% AFUE heats a 100 gallon storage tank in a laundry facility using a tunnel washer. Use of the tunnel washer will save the original laundry site an estimated 1,062,734 gallons of water the below example savings:

$$\begin{aligned} \Delta\text{Therms} &= ((T_{\text{out}} - T_{\text{in}}) * \text{HotWaterUse}_{\text{Gallon}} * \gamma_{\text{water}} * 1 * (1/\text{Eff}))/100,000 \\ &= ((125 - 54) * 1,062,734 * 8.33 * 1 * (1/0.8))/100,000 \\ &= 7856 \text{ therms} \end{aligned}$$

#### WATER AND OTHER NON-ENERGY IMPACT DESCRIPTIONS AND CALCULATION

The water savings from the tunnel washing machines will help preserve water supplies, extend the life of water treatment and wastewater treatment plants. The reduction in detergent requirements will also have cost and environmental benefits.

#### DEEMED O&M COST ADJUSTMENT CALCULATION

Actual O&M cost adjustments should be used for this measure.<sup>551</sup>

**MEASURE CODE: CI-HWE-TUWA-V02-240101**

**REVIEW DEADLINE: 1/1/2029**

<sup>550</sup>US DOE Building America Program, Building America Analysis Spreadsheet (for Chicago, IL), Office of Energy Efficiency & Renewable Energy

<sup>551</sup> Annual repair & maintenance costs have been estimated at \$19,000 per unit. Energy Savings Potential and RD&D Opportunities for Commercial Building Appliances, Navigant Consulting, December 21, 2009. [https://www1.eere.energy.gov/buildings/publications/pdfs/corporate/commercial\\_appliances\\_report\\_12-09.pdf](https://www1.eere.energy.gov/buildings/publications/pdfs/corporate/commercial_appliances_report_12-09.pdf)

## 4.3.12 Tank Insulation

### DESCRIPTION

This measure provides rebates for installation of 1” or 2” fiberglass, mineral fiber, or other types of insulation with similar properties to existing bare heated tanks for industrial and some commercial installations. Storage tanks can hold any heated material including, but not limited to, hot water, thermal oil, chemicals, and asphalt.

Default per square foot savings estimates are provided for both exposed indoor and outdoor storage tanks that are heated by heat transfer fluids including steam and thermal oil. Only systems heated with natural gas are eligible for this measure.

Indoor tanks require at least 1” of insulation and outdoor tanks must have at least 2 inches of insulation and include an all-weather protective jacket. New advanced insulating materials may be thinner and savings can be calculated with 3E Plus v4.1.<sup>552</sup>

This measure was developed to be applicable to the following program types: RF (Retrofit), DI (Direct Install). If applied to other program types, the measure savings should be verified.

### DEFINITION OF EFFICIENT EQUIPMENT

The efficient case is installing tank insulation to an uninsulated, heated material storage tank. Indoor tanks must have at least 1 inch of insulation (R-value of 2.1) and outdoor tanks must have at least 2” of insulation (R-value of 4.2) and include an all-weather protective jacket.

### DEFINITION OF BASELINE EQUIPMENT

The base case for savings estimates is a bare, steel tank. Other tank materials can be used to calculate savings with 3E Plus v4.1. Tanks are not required by mechanical codes to be insulated and are commonly found without any insulation.<sup>553</sup>

### DEEMED LIFETIME OF EFFICIENT EQUIPMENT

The measure life is assumed to be 15 years.<sup>554</sup>

### INCREMENTAL MEASURE COST

The incremental cost for this measure is \$12/ft<sup>2</sup>.<sup>555</sup>

### LOADSHAPE

N/A

### COINCIDENCE FACTOR

N/A

---

<sup>552</sup> 3E Plus v4.1 is a heat loss calculation software provided by the NAIMA (North American Insulation Manufacturer Association).

<sup>553</sup> ASHRAE Handbook – Fundamentals 2017 lists requirements for pipe and duct insulation but does not mention tank insulation.

<sup>554</sup> Based on the California Municipal Utilities Association Technical Reference Manual Third Edition measure 14.1.

<sup>555</sup> Based on RS Means Data Line Number 220719101162.

**Algorithm**

**CALCULATION OF ENERGY SAVINGS**

**ELECTRIC ENERGY SAVINGS**

N/A

**SUMMER COINCIDENT PEAK DEMAND SAVINGS**

N/A

**FOSSIL FUEL SAVINGS**

$$\Delta\text{Therms} = [\text{ESF}_b * A_b + \text{ESF}_e * A_e] * \text{Hours} * \text{LF} * \text{TRF} / (100,000 * \eta)$$

Where:

$\text{ESF}_b$  = Energy savings factor from tank body defined as the difference in heat loss between an insulated condition and a bare condition as found in table below [Btu/hr/ft<sup>2</sup>]

$A_b$  = Area of tank body [ft<sup>2</sup>]  
= Actual

$\text{ESF}_e$  = Energy savings factor from tank endcap(s) defined as the difference in heat loss between an insulated condition and a bare condition as found in table below [Btu/hr/ft<sup>2</sup>]

$A_e$  = Area of endcap(s) [ft<sup>2</sup>]  
= Combined area of endcaps if tank is oriented horizontally, separate areas if tank is oriented vertically or only one endcap is insulated  
= Actual

Hours = Operating hours of heating system  
= Actual

LF = Load factor of heating system  
= Annual gas consumption / (Hours \* Nameplate Heating Capacity)

TRF = Thermal Regain Factor for tank location and use, see table below. The Custom TRF option may be used on any tank location, including tank locations with deemed TRFs specifically listed in the table below, if supporting justification and calculations for the Custom TRF are provided.

May vary seasonally such as:  $\text{TRF}[\text{summer}] * \text{summer hours} + \text{TRF}[\text{winter}] * \text{winter hours}$  where TRF values reflecting summer and winter conditions are apportioned by the hours for those conditions. TRF may also be adjusted by building specific balance point temperature (BPT) and operating hours above and below that BPT.<sup>556</sup>

Tank Location	Assumed Regain	TRF, Thermal Regain Factor
Outdoor	0%	1.0
Indoor, conditioned, annual use (e.g. hot water or process loads), 55°F BPT	45%	0.55

<sup>556</sup> Zimmerman, Cliff, Franklin Energy, "Thermal Regain Factor\_4-30-14.docx", 2014. Based on climate zone 2. Note 'Location not specified – Commercial' assumes pipes provide DHW year round. 'Location not specified – Commercial' assumes semi-conditioned annual usage.

Tank Location	Assumed Regain	TRF, Thermal Regain Factor
Indoor, semi-conditioned, annual use, 55°F BPT	16%	0.84
Indoor, unconditioned spaces, (no heat transfer to conditioned space)	0%	1.0
Location not specified - Commercial	45%	0.55
Location not specified – Industrial	16%	0.84
Custom	Custom	1 – assumed regain

- 100,000 = Conversion factor from BTUs to Therms
- $\eta$  = Efficiency of heating equipment used to heat tanks  
= Actual, or if unknown assume 79%<sup>557</sup>

The following table shows conductivities and maximum temperature ratings of similar insulation materials. The average value was used with 3EPlus software to generate the Energy Savings Factors used in the savings algorithm.

**Table 1 – Insulation types**

Insulation Type	Conductivity (Btu.in/ hr.ft <sup>2</sup> .°F @ 300°F)	Max Temp (°F)
Mineral Fiber Pipe and Tank Wrap	0.48	650
Mineral Fiber Board	0.44	850
Polyurethane	0.5	400
Average	0.47	

The tank surface temperature assumption depends on the system type. The following table should be used to select the appropriate Energy Savings Factor based on the fluid temperature:

**Table 2 – Heating fluid temperatures**

System Type	Fluid Temperature Assumption (°F)
Low Pressure Steam (< 15 psi)	225
High Pressure Steam (> 60 psi)	315
Thermal Oil	425

The energy savings factors (ESF) were developed using the 3E Plus v4.1 software program, and are derived as the difference in heat loss per square foot of a bare tank and an insulated tank.<sup>558</sup> The energy savings analysis is based on adding 1" (indoor) or 2" (outdoor) thick insulation around bare tanks. Outdoor conditions are assumed to be 48.6°F with a wind speed of 5.0 mph.<sup>559</sup> The thermal conductivity of tank insulation varies by material and

<sup>557</sup> Minimum efficiency for steam boilers as set in IECC 2018 code C403.3.2.

<sup>558</sup> Tank insulation calc\_8-4-20.xlsx including tables obtained from 3E Plus v4.1 software.

<sup>559</sup> DOE Weather Data, TMY3 (Typical Meteorological Year), developed by NREL for the average ambient temperature and wind speed for Aurora, IL. Adjusted to align with ASHRAE 24.4 Terrain Category 1 for Large city centers with densely populated, tall buildings (2017).

temperature rating; to obtain a typical value, a range of materials allowed for this measure was averaged. For insulation materials not in the table above, use 3E Plus v4.1 software to calculate  $ESF_b$  and  $ESF_e$ .

**Energy Savings Factors [Btu/hr/ft<sup>2</sup>]**

		Low Pressure Steam	High Pressure Steam	Thermal Oil
Vertical Tank - Body	Indoor	290.2	559.0	991.8
	Outdoor	373.4	666.0	1132.0
Horizontal Tank - Body	Indoor	290.2	559.0	991.8
	Outdoor	373.4	666.0	1132.0
Vertical Tank End - Top	Indoor	336.8	642.8	783.9
	Outdoor	426.3	756.2	1269.6
Vertical Tank End - Bottom	Indoor	189.8	380.0	712.1
	Outdoor	288.1	515.7	897.3
Horizontal Tank End	Indoor	290.2	559.0	991.8
	Outdoor	373.4	666.0	1132.0

**For example**, an outdoor, vertical, cylindrical tank with a radius of 5 ft and height of 15 ft heated by a thermal oil heating system that is insulated around the body and top of the tank would save (assuming 4380 hours of operation, 70% load factor, and 78% efficient thermal oil heater):

$$\Delta\text{Therms} = [ESF_b * A_b + ESF_e * A_e] * \text{Hours} * LF * TRF / (100,000 * \eta)$$

$$ESF_b = 1132.0 \text{ Btu/hr/ft}^2$$

$$A_b = 2 * \pi * r * h$$

$$= 471.2 \text{ ft}^2$$

$$ESF_e = 1269.6 \text{ Btu/hr/ft}^2$$

$$A_e = \pi * r^2$$

$$= 78.5 \text{ ft}^2$$

$$\text{Hours} = 4380$$

$$LF = 0.7$$

$$TRF = 1.0$$

$$\eta = 0.78$$

$$\Delta\text{Therms} = [1132.0 * 471.2 + 1269.6 * 78.5] * 4380 * 0.7 * 1 / (100,000 * 0.78)$$

$$= 24,884 \text{ therms}$$

**WATER AND OTHER NON-ENERGY IMPACT DESCRIPTIONS AND CALCULATION**

N/A

**DEEMED O&M COST ADJUSTMENT CALCULATION**

N/A

**MEASURE CODE: CI-HWE-TKIN-V03-240101**

**REVIEW DEADLINE: 1/1/2029**

### 4.3.13 Tankless Water Heater Array

#### DESCRIPTION

A Central Condensing Tankless Water Heater (CCTWH) array is a type of domestic hot water heating system formed by integrating multiple condensing tankless water heating units in a modular style to increase overall system capacity, turndown capability and to reduce standby energy losses. Hot water energy savings resulting from reduction in standby losses and improved system efficiency are detailed in this measure.

Traditional domestic water heaters for large commercial applications come in two basic designs: conventional tank type water heaters and boilers with external storage tanks. Both these systems produce large volumes of hot water even when there is no demand, resulting in significant standby energy losses. For facilities with peak domestic hot water loads, the water heating system will be sized and installed to meet peak hot water loads. These large systems will often have low turndown ratios and will result in lower efficiencies during lower hot water loads.

On the other hand, gas fired instantaneous or tankless water heaters are defined by code for federal regulations<sup>560</sup> as water heaters which produce not less than 4,000 Btu/hr per gallon of storage. Multiple individual condensing gas fired tankless water heating units are integrated together with specific system controls to form a CCTWH array.

As a replacement to conventional central domestic hot water systems, CCTWH arrays primarily yield energy savings by minimizing standby heat losses and providing high turn-down ratios and there by maximizing the “condensing” efficiency of the water heating system. The temperature difference between supply water temperature and inlet water temperature of the water heater determines the efficiency if the water heater. The inlet/return water temperatures need to be lower to achieve higher efficiencies. Without a storage tank, CCTWH arrays have lower thermal mass and lower return water temperatures to achieve high condensing level efficiencies. Typical points of application of CCTWH array are building types with high peak water heating demands and high turn down ratios like Multifamily, Hotels/ Motels, Hospitals and Universities/ Schools.

This measure involves estimation of hot water energy savings for multiple varying building specific and system specific parameter inputs to estimate hot water usage and energy savings. An external spreadsheet calculator<sup>561</sup> located at [link] has been developed which utilizes the following inputs to facilitate the estimation of the hot energy savings for this measure.

- Measure type (New construction NC or Time of sale TOS)
- Building type<sup>562</sup>
  - Application type: Multifamily, Hotels and Motels.
    - Number of units served by the water heater.
  - Application type: Hospital and Healthcare buildings
    - Number of beds in the spaces served by the water heater.
  - Application type: Offices, Schools, and Universities.
    - Daily occupancy in the spaces served by the water heater.
  - Application type: Other Commercial buildings.
    - Gross building floor area served by the water heater.
- Climate Zone: Rockford, Chicago, Springfield, Belleville, Marion
- Baseline water heater type, firing rate, storage volume and rated stand by loss for measure type Time of sale (TOS).
- CCTWH array firing rate, storage volume, peak flow rate at 70°F ΔT and rated standby loss.

<sup>560</sup>Gas fired Instantaneous water heater as defined in code for federal regulations. [eCFR :: 10 CFR Part 431 Subpart G -- Commercial Water Heaters, Hot Water Supply Boilers and Unfired Hot Water Storage Tanks](#)

<sup>561</sup> Externally attached spreadsheet tool 'Energy Savings Calculator for Central Condensing Tankless Water Heater Array.xlsm'.

<sup>562</sup> Building type definitions are as defined in Illinois Technical Reference Manual version 11, Volume 1: Overview and User Guide, Section 3.6 Glossary. [IL-TRM Effective 010123 v11.0 Vol 1 Overview 09222022 FINAL.pdf \(ilsag.info\)](#)

This measure was developed to be applicable to the following program types: NC and TOS. If applied to other program types, the measure savings should be verified.

**DEFINITION OF EFFICIENT EQUIPMENT**

Central Condensing Tankless Water Heater array (CCTWH array) are formed by integrating individual gas fired condensing tankless water heating units into a modular system with specific system controls. Gas fired Instantaneous or Tankless water heaters shall produce not less than 4,000 Btu/hr per gallon of storage as defined by federal code for regulations<sup>563</sup>. CCTWH array system to be used as part of this measure should be greater than 200,000 Btu/hr and produce not less than 4,000 Btu/hr per gallon of stored water. CCTWH array system as a part of the measure shall have a rated thermal efficiency greater than 90%.

**DEFINITION OF BASELINE EQUIPMENT**

Time of Sale: This measure type is only applicable for existing commercial gas fired water heaters being replaced after the end of their useful life. The baseline condition is assumed to be a new standard water heater of same type as the existing unit being replaced. The efficiency of the baseline water heater in this case, would be or minimum efficiency as required by the federal standards<sup>564</sup>. If existing equipment type is unknown, the baseline condition is assumed to be a standard commercial gas fired storage type water heater meeting federal minimal efficiency standards listed in table below.

New Construction: The baseline condition is assumed to be a new standard commercial gas fired storage type water heater meeting federal minimum efficiency standards listed in table below.

Equipment Type <sup>565</sup>	Sub Category	Draw Pattern	Federal Standard – Uniform Energy Factor
<u>Commercial</u> Gas Storage Water Heaters (Including Storage water heaters and Service hot water boilers with external storage tanks)	>75,000 Btu/hr	All	80% E <sub>thermal</sub> , Btu/hr Standby Losses = (Q /800 + 110vRated Storage Volume in Gallons), Btu/hr
<u>Commercial</u> Gas Instantaneous Water Heaters	<10 gal and >200,000 Btu/hr	All	80% E <sub>thermal</sub> , Btu/hr Standby Losses = NA
	≥10 gal and >200,000 Btu/hr	All	80% E <sub>thermal</sub> , Btu/hr Standby Losses = (Q /800 + 110vRated Storage Volume in Gallons), Btu/hr

For the purpose of calculating baseline water heater standby losses in measure type NC, Capacity of the Baseline water heater (NC) is calculated as follows:

$$(NC)Baseline\ water\ heater\ capacity\ (Btu/hr) = Recovery\ demand * \Delta T * 8.33/\eta$$

$$Recovery\ demand\ (gph) = Peak\ flow\ (gpm) * 30$$

<sup>563</sup> Gas fired Instantaneous water heater as defined in code for federal regulations. [eCFR :: 10 CFR Part 431 Subpart G -- Commercial Water Heaters, Hot Water Supply Boilers and Unfired Hot Water Storage Tanks](#)

<sup>564</sup> Residential-Duty and Commercial Federal Standard are from DOE Standard 10 CFR 431. [eCFR :: 10 CFR Part 431 Subpart G -- Commercial Water Heaters, Hot Water Supply Boilers and Unfired Hot Water Storage Tanks](#)

<sup>565</sup> Commercial Water heater equipment type definitions are per U.S Department of energy, federal code for regulation standards.



Peak flow (gpm)	= Peak flow of the CCTWH array at 70 °F ΔT temperature rise.
30	= A peak flow of 30 minutes is assumed to estimate peak gallons per hour recovery demand.
8.33	= 8.33 lb/gal of water
η	= 0.8 (Efficiency of the (NC) Baseline water heater)
(NC) Baseline water heater storage (Gal)	= (NC) Baseline water heater capacity (Btu/hr) /3,999
3,999	= Conversion factor to estimate minimum storage volume to be defined as a storage type water heater per U.S. federal code for standards.

Note that (NC) Baseline water heater capacity and (NC) Baseline water heater storage are only utilized to calculate baseline system standby loss for calculating measure energy savings.

**DEEMED LIFETIME OF EFFICIENT EQUIPMENT**

The expected measure life is assumed to be 20 years<sup>566</sup>.

**DEEMED MEASURE COST**

Actual costs should be used where available. Total equipment cost assumptions for the measure can be used from table below if actual costs are unknown. Depending on actual site demand requirements, CCTWH array is expected to have higher firing rate than a storage water heater, to meet the same hot water demand. While computing incremental costs for this measure, corresponding firing rates shall be utilized for the Baseline water heater and the CCTWH array.

Capacity	Total Equipment Cost- CCTWH Array	Total Equipment Cost Baseline <sup>567</sup>	
		Storage Type Water Heater	Service Hot Water Boiler with Storage Tanks
≤800 kBtu/hr	14.45 \$/kBtu/hr <sup>568</sup>	34.67 \$/kBtu/hr	27.50 \$/kBtu/hr
>800 kBtu/hr	31.21 \$/kBtu/hr <sup>569</sup>		

Incremental Cost	= (Unit Cost CCTWH Array * Eff firing rate) – (Unit Cost Baseline * Baseline firing rate)
Unit Cost	= Cost per firing rate of the water heating equipment (\$/kBtu/hr).
Eff firing rate	= Firing rate(kBtu/hr) of the Central condensing tankless water heater array.
Baseline firing rate	= Firing rate(kBtu/hr) of the Baseline domestic water heater.

<sup>566</sup> California ETRM, Tankless water heater commercial measure (Version SWWH006-07) lists a useful life of 20 years. California Public Utilities Commission (CPUC), Energy Division. 2014. "DEER2014-EUL-table-update\_2014-02-05.xlsx."

<https://www.caetrm.com/login/?next=/measure/SWWH006/07/>

<sup>567</sup> Baseline install costs are based on data from [2010-2012 WO017 Ex Ante Measure Cost Study - Final Report.pdf \(calmac.org\)](#). Only equipment and miscellaneous costs are considered excluding labor costs for a non-condensing 82% TE storage type water heater. Average of equipment and miscellaneous costs for Large storage water heater Et=80% and SHW Boilers Et=82% are used to estimate equipment cost per kBtu/hr.

<sup>568</sup> Install cost from Swierczyna, R., P. Glanville, M. Mensinger Jr., A. Haynor, B. Schoenbauer. 2022. Demonstration of Packaged Central Condensing Tankless Water Heating Systems in Multifamily Buildings. Minnesota Commerce Department. <https://mn.gov/commerce/energy/conserving-energy/applied-research-development/>

<sup>569</sup> Install cost for CCTWH array greater than 800 kBtu/hr are from GTI Energy field demonstration projects in Illinois.

For baseline water heater firing rate in measure type NC, refer to Definition of baseline equipment section.

**LOADSHAPE**

N/A

**COINCIDENCE FACTOR**

N/A

---

---

**Algorithm**

---

---

**CALCULATION OF ENERGY SAVINGS**

**ELECTRIC ENERGY SAVINGS**

There are no anticipated electrical energy savings for this measure.

**SUMMER COINCIDENT PEAK DEMAND SAVINGS**

N/A

**NATURAL GAS SAVINGS**

$$\Delta\text{Therms} = \{[G \times 8.33 \times 1 \times (T_{\text{out}} - T_{\text{in}}) \times ((1/\eta_{\text{base}}) - (1/\eta_{\text{eff}}))] + (S_{\text{Lbase}} - S_{\text{Leff}})\} / 1,000,00$$

Where:

G = Annual hot water use (in gallons).

= Actual annual hot water usage (If hot water usage is metered in measure type TOS)

= Average daily hot water use x Operating days in a year. (if daily use is listed in table below.

Operating days in a year = Actual or If unknown, use values from table below.

Building Type <sup>570 571</sup>	Operating days per year
Offices	250
Restaurant	365
Retail	365
Grocery stores/ Convenience stores	365
Warehouses	250
Schools	200
Universities	200
Health	365
Hotels, Motels	365
Multifamily	365
Other Commercial	250

Average daily hot water use to be calculated from table below based on building type.

Building Type	Consumption	Unit
Multi-family	36.9	Gal/unit/day <sup>572</sup>
Hotels <=20 units	20	Gal/unit/day <sup>573</sup>
Hotels 21-99 Units	14	Gal/unit/day
Hotels 100+ units	10	Gal/unit/day
School (Jr/Sr High)	1.8	Gal/student/day
Elementary school	0.6	Gal/student/day
Universities	1.8	Gal/person/day
Hospitals	18.4	Gal/bed/day
Office	1	Gal/person/day
Retail >=30,000 SF	1,354	Gal/1000 SF/year <sup>574</sup>
Retail < 30,000 SF	6,111	Gal/1000 SF/year
Restaurants	44,439	Gal/1000 SF/year
Grocery store	697	Gal/1000 SF/year
Convenience	4,594	Gal/1000 SF/year
Warehouse	1,239	Gal/1000 SF/year
Other Commercial	3,941	Gal/1000 SF/year

8.33 = Density of water lb/gal.

1 = Specific heat capacity of water Btu/lb °F.

Tout = water heater set point (oF) (demand temperature) is assumed to be 125 oF. If custom higher water temperatures are used, actual tank water temperature should be verified.

Tin = Average inlet water temperature (°F) is based on the building location nearest to zones listed in table below.

Typical Entering Cold-Water Temperatures <sup>575</sup> in °F			
Zones	Min	Avg	Max
(1)Rockford	40.86	53.80	66.31

Typical Entering Cold-Water Temperatures <sup>575</sup> in °F			
(2)Chicago O’Hare	44.10	56.17	67.85
(3)Springfield	46.05	59.38	72.30
(4)Belleville	48.24	60.08	71.55
(5)Marion	49.63	62.09	74.19

- $\eta_{base}$  = Rated efficiency of baseline water heater in Thermal efficiency (Et) can be actual value if known or can be taken from per table in definition of baseline equipment.
- $\eta_{new}$  = Rated efficiency of the efficient CCTWH array in Thermal efficiency (Et).
- SL<sub>base</sub> = Annual Standby energy loss of the baseline water heater in btu.  
= SL rated base X H
- SL rated base = Rated Standby loss rating of the baseline water heater in Btu/hr.  
= Actual or if unknown, Use calculation below to estimate standby losses.  
=  $(Q / 800 + 110 \nu \text{Rated Storage Volume in Gallons}), \text{Btu/hr}$
- Q = Capacity/ Firing rate of the Baseline water heater in Btu/hr
- H = 8760 annual hours of operation is assumed for estimating stand by losses.
- SL<sub>eff</sub> = Annual Standby energy loss of the efficient CCTWH array in btu.  
= SL rated eff X H
- SL rated eff = Rated Standby loss rating of the efficient CCTWH array in Btu/hr  
= or Actual Standby loss rating values based on CCTWH system operation. This will need to be verified to be utilized in the measure.  
=If unknown and CCTWH array rated storage volume is greater than or equal to 10 gallons, assume a standby loss of,  
$$Q_{eff} / 800 + 110 \nu \text{Rated Storage Volume in Gallons}), \text{Btu/hr}$$
- Q<sub>eff</sub> = Capacity/ Firing rate of the CCTWH array in Btu/hr.

<sup>570</sup> Sezgan, O et al. Technology data characterizing water heating in commercial buildings: Application to end use forecasting, Ernest Orlando Lawrence Berkeley National Laboratory, December 1995. [lbnl-37398e.pdf \(lbl.gov\)](#)

<sup>571</sup> 2020 State of Ohio Energy efficiency technical reference manual, Volume III: Commercial and Industrial market sector. “Technical Reference Manual (TRM) for Ohio Senate Bill 221 Energy Efficiency and Conservation Program and 09-512-GEUNC”, October 15, 2009. Based on Ohio utility supply profiles. [ViewImage.aspx \(state.oh.us\)](#)

<sup>572</sup> 2022 IL Technical reference manual, measure 4.3.7, referenced Deoreo, B., and P. Mayer. Residential End Uses of Water Study Update. Forthcoming. ©2015 Water Research Foundation.

<sup>573</sup> 2019 ASHRAE Applications handbook, chapter 51 service water heating for Hotels, Schools/ Universities and offices water consumption.

<sup>574</sup> 2022 IL Technical reference manual, version 11, volume 2, section 4.3.1., lists consumption/ cap for retail spaces, restaurants, grocery stores, convenience stores, Warehouses and other commercial spaces. Update with reference from 4.3.1

<sup>575</sup> Cold water temperatures are taken From US DOE, Building America Analysis Spreadsheets

**For example**, savings for a CCTWH array with 796 kbtu/hr input rating, 20 gpm peak flow at 70 °F ΔT and 96% TE is installed serving 23 units in a multi-family building in Chicago, replacing a storage type water heater 199 kbtu/hr input rating, 100-gallon storage and 80% TE, is calculated as follows:

Following inputs listed below shall be utilized to estimate Therms savings in the external spreadsheet calculator.

Description	Input	Calculated Annual Therms Savings
Measure type	Time of Sale (TOS)	<b>489 Therms</b>
Building Type	Multi-family	
Number of units served by the water heater	23	
Building location: Climate Zone	Climate Zone2: Chicago	
Baseline water heater type	Commercial gas fired storage water heater	
Baseline water heater Firing rate input	199 kbtu/hr	
Baseline water heater storage capacity	100 Gallons	
CCTWH array system firing rate input	796 kbtu/hr	
CCTWH array system Thermal efficiency	96%	

The same example; when a CCTWH array with 796 kbtu/hr input rating, 20 gpm peak flow at 70 °F ΔT and 96% TE is installed serving 23 units in a multi-family building in Chicago is installed in New Construction, Hot water energy savings are estimated as based on input listed below.

Description	Input	Calculated Annual Therms Savings
Measure type	New Construction (NC)	<b>518 Therms</b>
Building Type	Multi-family	
Number of units served by the water heater	23	
Building location: Climate Zone	Climate Zone2: Chicago	
Baseline water heater type	Commercial gas fired storage water heater	
CCTWH array system firing rate input	796 kbtu/hr	
CCTWH array system Thermal efficiency	96%	
CCTWH array system Peak flow at 70 °F temperature rise	20 gpm	

**WATER AND OTHER NON-ENERGY IMPACT DESCRIPTIONS AND CALCULATION**

N/A

**DEEMED O&M COST ADJUSTMENT CALCULATION**

N/A

**MEASURE CODE: CI-HWE-TWHA-V01-240101**

**REVIEW DEADLINE: 1/1/2029**

## 4.4.HVAC End Use

Many of the commercial HVAC measures use equivalent full load hours (EFLH) to calculate heating and cooling savings. The tables with these values are included in this section and referenced in each measure.

To calculate the updated EFLHs by building type and climate zone provided below, most of the eQuest models that were previously developed by a TAC Subcommittee utilizing building energy models originally developed for ComEd<sup>576</sup>, were migrated to OpenStudio by a parametric calibration process. The parametric runs were controlled with a genetic learning algorithm to characteristically adjust the seed models to achieve an acceptable target error against the existing eQuest model population. The breadth of the characteristic variations were informed through a sensitivity analysis, the IL joint assessment survey, and the existing eQuest models. The DOE prototypical models served as the initial seed model for most instances of calibration except where a direct map to available prototypes was unavailable.

The building characteristics of the eQuest models can be found in the reference table named “EFLH Building Descriptions Updated 2014-11-21.xlsx”. The OpenStudio models are based upon the DOE Prototypes described in NREL’s “U.S. Department of Energy Commercial Reference Building Models of the National Building Stock” and a calibration log file that documents all of the variations made to each model to get them calibrated is provided in “IL-Calibration-Log\_2019-08-27.xlsx”. These documents and all the models are all available on the SharePoint site.

Note, for greenhouse boiler control measures, like Modulating Boiler Controls and/or Boiler Oxygen Trim Controls it is recommended to use methodology detailed in 4.4.21 Linkageless Boiler Controls for Space Heating and 4.4.22 Oxygen Trim Controls for Space Heating Boilers, respectively.

Note where a measure installation is within a building or application that does not fit with any of the defined building types below, the user should apply custom assumptions where it is reasonable to estimate them, else the building of best fit should be utilized.

Equivalent Full Load Hours for Heating (EFLH<sub>Heating</sub>) for Existing Buildings:

Building Type	Heating EFLH Existing Buildings					Model Source
	Zone 1 (Rockford)	Zone 2 (Chicago)	Zone 3 (Springfield)	Zone 4 (Belleville)	Zone 5 (Marion)	
Assembly	1,787	1,831	1,635	1,089	1,669	eQuest
Assisted Living	1,683	1,646	1,446	1,063	1,277	eQuest
Auto Dealership	2,981	2,950	2,694	2,368	2,437	OpenStudio
College	1,256	1,293	1,138	1,116	1,131	OpenStudio
Convenience Store	1,481	1,368	1,214	871	973	eQuest
Drug Store	2,848	2,947	2,568	2,362	2,516	OpenStudio
Elementary School	1,614	1,603	1,409	1,209	1,269	OpenStudio
Emergency Services	2,757	2,670	2,383	2,149	2,186	OpenStudio
Garage	985	969	852	680	752	eQuest
Greenhouse – w/ Curtains	4,320	4,059	3,493	2,996	2,933	Virtual Grower 3.1
Greenhouse – w/o Curtains	4,344	4,081	3,513	3,012	2,949	Virtual Grower 3.1
Grocery	1,467	1,551	1,364	1,367	1,375	OpenStudio
Healthcare Clinic	1,446	1,526	1,452	1,553	1,574	OpenStudio
High School	1,807	1,855	1,649	1,591	1,622	OpenStudio
Hospital - CAV no econ <sup>577</sup>	1,216	1,220	1,072	1,001	1,028	OpenStudio
Hospital - CAV econ <sup>578</sup>	1,387	1,398	1,252	1,222	1,269	OpenStudio

<sup>576</sup> A full description of the ComEd model development is found in “ComEd Portfolio Modeling Report. Energy Center of Wisconsin July 30, 2010”.

<sup>577</sup> Based on model with single duct reheat system with a fixed outdoor air volume.

<sup>578</sup> Based on model with single duct reheat system with airside economizer controls, with constant volume zone reheat boxes and single speed fan motors.

Building Type	Heating EFLH Existing Buildings					Model Source
	Zone 1 (Rockford)	Zone 2 (Chicago)	Zone 3 (Springfield)	Zone 4 (Belleville)	Zone 5 (Marion)	
Hospital - VAV econ <sup>579</sup>	665	697	628	646	615	OpenStudio
Hospital - FCU	1,622	1,571	1,374	1,220	1,281	OpenStudio
Hotel/Motel	1,597	1,634	1,468	1,376	1,451	OpenStudio
Hotel/Motel - Common	1,670	1,733	1,549	1,496	1,557	OpenStudio
Hotel/Motel - Guest	1,555	1,597	1,433	1,316	1,400	OpenStudio
Manufacturing Facility	1,048	1,013	939	567	634	eQuest
MF - High Rise	1,565	1,540	1,448	1,089	1,125	OpenStudio
MF - High Rise - Common	537	558	501	480	499	OpenStudio
MF - High Rise - Residential	1,665	1,666	1,512	1,145	1,207	OpenStudio
MF - Mid Rise	1,730	1,782	1,589	1,538	1,560	OpenStudio
Movie Theater	1,916	1,905	1,718	1,288	1,538	eQuest
Office - High Rise - CAV no econ	995	1,036	933	786	832	OpenStudio
Office - High Rise - CAV econ	1,001	1,051	929	803	851	OpenStudio
Office - High Rise - VAV econ	1,552	1,432	1,239	1,077	1,098	OpenStudio
Office - High Rise - FCU	1,015	993	899	773	809	OpenStudio
Office - Low Rise	2,825	2,625	2,365	2,007	2,040	OpenStudio
Office - Mid Rise	1,672	1,629	1,454	1,356	1,399	OpenStudio
Religious Building	1,603	1,504	1,440	1,054	1,205	eQuest
Restaurant	1,326	1,328	1,179	1,091	1,122	OpenStudio
Retail - Department Store	1,365	1,322	1,193	1,034	1,088	OpenStudio
Retail - Strip Mall	1,347	1,325	1,183	1,064	1,096	OpenStudio
Warehouse	1,285	1,286	1,180	1,147	1,224	OpenStudio
Unknown	1,709	1,678	1,508	1,287	1,411	n/a

Equivalent Full Load Hours for Heating (EFLH<sub>Heating</sub>) for New Construction:

Building Type	Heating EFLH New Construction					Model Source
	Zone 1 (Rockford)	Zone 2 (Chicago)	Zone 3 (Springfield)	Zone 4 (Belleville)	Zone 5 (Marion)	
Auto Dealership	1,286	1,185	1,279	1,138	1,078	OpenStudio
College	942	834	906	831	818	OpenStudio
Drug Store	1,023	930	1,017	889	822	OpenStudio
Elementary School	949	878	943	861	859	OpenStudio
Emergency Services	480	352	501	407	347	OpenStudio
Grocery	2,795	2,788	2,549	2,380	2,597	OpenStudio
Healthcare Clinic	1,534	1,417	1,555	1,395	1,371	OpenStudio
High School	1,502	1,549	1,368	1,283	1,299	OpenStudio
Hospital - CAV no econ	2,345	2,207	2,318	2,110	2,195	OpenStudio
Hospital - CAV econ	2,345	2,207	2,318	2,110	2,195	OpenStudio
Hospital - VAV econ	2,345	2,207	2,318	2,110	2,195	OpenStudio
Hospital - FCU	2,345	2,207	2,318	2,110	2,195	OpenStudio
Hotel/Motel - Residential	1,412	1,243	1,439	1,405	1,146	OpenStudio
Hotel_Motel_Common	1,554	1,415	1,519	1,410	1,361	OpenStudio

<sup>579</sup> Based on model with single duct reheat system with airside economizer controls, zone VAV reheat boxes and VFD fan motors.



Building Type	Heating EFLH New Construction					Model Source
	Zone 1 (Rockford)	Zone 2 (Chicago)	Zone 3 (Springfield)	Zone 4 (Belleville)	Zone 5 (Marion)	
Hotel_Motel_Guest	1,538	1,083	1,554	1,381	987	OpenStudio
MF - High Rise	1,308	884	1,361	1,125	865	OpenStudio
MF - High Rise - Common	1,581	1,280	1,590	1,349	1,220	OpenStudio
MF - High Rise - Residential	1,352	946	1,413	1,174	917	OpenStudio
MF - Mid Rise	1,637	1,385	1,637	1,434	1,322	OpenStudio
Office - High Rise - FCU	987	870	1,001	893	837	OpenStudio
Office - High Rise - VAV econ	987	870	1,001	893	837	OpenStudio
Office - Mid Rise	867	759	892	792	701	OpenStudio
Office - High Rise - CAV no econ	967	854	971	876	804	OpenStudio
Office Low Rise	954	916	826	667	664	OpenStudio
Restaurant	787	797	671	811	820	OpenStudio
Retail - Department Store	1,286	1,185	1,279	1,138	1,078	OpenStudio
Retail - Strip Mall	973	867	972	857	777	OpenStudio
Warehouse	1,413	1,390	1,398	1,298	1,290	OpenStudio
Unknown	1,133	1,064	1,091	982	960	n/a

Equivalent Full Load Hours for Cooling (EFLH<sub>cooling</sub>) for Existing Buildings:

Building Type	Cooling EFLH Existing Buildings					Model Source
	Zone 1 (Rockford)	Zone 2 (Chicago)	Zone 3 (Springfield)	Zone 4 (Belleville)	Zone 5 (Marion)	
Assembly	725	796	937	1,183	932	eQuest
Assisted Living	1,475	1,457	1,773	2,110	1,811	eQuest
Auto Dealership	996	1,051	1,343	1,582	1,414	OpenStudio
College	572	564	676	776	613	OpenStudio
Convenience Store	1,088	1,067	1,368	1,541	1,371	eQuest
Drug Store	858	943	1,133	1,279	1,092	OpenStudio
Elementary School	834	837	999	1264	967	OpenStudio
Emergency Services	2,983	3,009	3,762	4,030	3,740	OpenStudio
Garage	934	974	1,226	1,582	1,383	eQuest
Grocery	826	914	1,151	1,329	1,240	OpenStudio
Healthcare Clinic	1,220	1,294	1,505	1,658	1,534	OpenStudio
High School	892	883	1,066	1,397	1,018	OpenStudio
Hospital - CAV no econ	1,719	1,799	2,068	2,238	2,066	OpenStudio
Hospital - CAV econ	1,267	1,302	1,604	1,798	1,592	OpenStudio
Hospital - VAV econ	3,313	3,332	3,458	3,546	3,311	OpenStudio
Hospital - FCU	1,575	1,562	1,921	1,979	1,812	OpenStudio
Hotel/Motel	1,106	1,148	1,453	1,605	1,435	OpenStudio
Hotel/Motel - Common	1,108	1,168	1,430	1,574	1,406	OpenStudio
Hotel/Motel - Guest	1,061	1,106	1,391	1,509	1,401	OpenStudio
Manufacturing Facility	1,010	1,055	1,209	1,453	1,273	eQuest
MF - High Rise	928	920	1,059	1,360	1,205	OpenStudio
MF - High Rise - Common	1,405	1,383	1,479	1,527	1,466	OpenStudio
MF - High Rise - Residential	764	807	976	1,216	1,147	OpenStudio
MF - Mid Rise	787	855	1,099	1,198	1,082	OpenStudio
Movie Theater	876	745	1,036	1,178	1,010	eQuest

Building Type	Cooling EFLH Existing Buildings					Model Source
	Zone 1 (Rockford)	Zone 2 (Chicago)	Zone 3 (Springfield)	Zone 4 (Belleville)	Zone 5 (Marion)	
Office - High Rise - CAV no econ	1,357	1,404	1,587	1,753	1,468	OpenStudio
Office - High Rise - CAV econ	922	937	1,138	1,274	1,000	OpenStudio
Office - High Rise - VAV econ	847	887	991	1,092	893	OpenStudio
Office - High Rise - FCU	1,083	1,116	1,269	1,348	1,266	OpenStudio
Office - Low Rise	1,796	1,790	2,233	2,342	2,219	OpenStudio
Office - Mid Rise	1,128	1,153	1,360	1,461	1,356	OpenStudio
Religious Building	861	817	967	1,159	1,067	eQuest
Restaurant	990	1,021	1,273	1,411	1,290	OpenStudio
Retail - Department Store	639	640	775	936	812	OpenStudio
Retail - Strip Mall	697	720	915	998	930	OpenStudio
Warehouse	252	265	363	377	379	OpenStudio
Unknown	1,003	1,019	1,230	1,403	1,236	n/a

Equivalent Full Load Hours for Cooling (EFLH<sub>cooling</sub>) for New Construction:

Building Type	Cooling EFLH New Construction					Model Source
	Zone 1 (Rockford)	Zone 2 (Chicago)	Zone 3 (Springfield)	Zone 4 (Belleville)	Zone 5 (Marion)	
Auto Dealership	806	923	792	938	1,028	OpenStudio
College	925	990	994	1,156	1,217	OpenStudio
Drug Store	813	931	744	836	1,083	OpenStudio
Elementary School	724	821	732	753	999	OpenStudio
Emergency Services	379	429	371	423	576	OpenStudio
Grocery	643	568	569	562	511	OpenStudio
Healthcare Clinic	1,964	2,093	1,932	2,055	2,221	OpenStudio
High School	1,807	1,642	2,093	2,292	1,830	OpenStudio
Hospital - CAV no econ	2,627	2,751	2,662	2,782	2,962	OpenStudio
Hospital - CAV econ	2,627	2,751	2,662	2,782	2,962	OpenStudio
Hospital - VAV econ	2,627	2,751	2,662	2,782	2,962	OpenStudio
Hospital - FCU	2,627	2,751	2,662	2,782	2,962	OpenStudio
Hotel/Motel - Residential	1,639	1,836	1,712	1,851	1,983	OpenStudio
Hotel_Motel_Common	2,343	2,472	2,286	2,400	2,590	OpenStudio
Hotel_Motel_Guest	788	1,024	846	1,073	1,164	OpenStudio
MF - High Rise	1,338	1,705	1,287	1,500	1,932	OpenStudio
MF - High Rise - Common	773	912	751	878	972	OpenStudio
MF - High Rise - Residential	1,299	1,663	1,245	1,451	1,882	OpenStudio
MF - Mid Rise	1,341	1,633	1,245	1,492	1,818	OpenStudio
Office - High Rise - FCU	1,296	1,465	1,281	1,477	1,574	OpenStudio
Office - High Rise - VAV econ	1,296	1,465	1,281	1,477	1,574	OpenStudio
Office - High Rise - CAV no econ	1,433	1,644	1,411	1,632	1,793	OpenStudio
Office - High Rise - CAV econ	1,361	1,375	1,604	1,715	1,617	OpenStudio
Office - Mid Rise	957	1,149	958	1,122	1,270	OpenStudio
Office Low Rise	947	989	1,090	1,302	1,076	OpenStudio
Restaurant	768	761	1,034	1,110	994	OpenStudio
Retail - Department Store	806	924	796	939	1,027	OpenStudio

Building Type	Cooling EFLH New Construction					Model Source
	Zone 1 (Rockford)	Zone 2 (Chicago)	Zone 3 (Springfield)	Zone 4 (Belleville)	Zone 5 (Marion)	
Retail - Strip Mall	722	789	667	834	911	OpenStudio
Warehouse	389	522	408	527	567	OpenStudio
Unknown	984	1,045	1,047	1,177	1,176	n/a

## 4.4.1 Air Conditioner Tune-up

### DESCRIPTION

An air conditioning system that is operating as designed saves energy and provides adequate cooling and comfort to the conditioned space

### DEFINITION OF EFFICIENT EQUIPMENT

In order for this characterization to apply, the efficient equipment is assumed to be a unitary or split system air conditioner at least 3 tons and preapproved by program. The measure requires that a certified technician performs the following items:

- Check refrigerant charge
- Identify and repair leaks if refrigerant charge is low
- Measure and record refrigerant pressures
- Measure and record temperature drop at indoor coil
- Clean condensate drain line
- Clean outdoor coil and straighten fins
- Clean indoor and outdoor fan blades
- Clean indoor coil with spray-on cleaner and straighten fins
- Repair damaged insulation – suction line
- Change air filter
- Measure and record blower amp draw

A copy of contractor invoices that detail the work performed to identify tune-up items, as well as additional labor and parts to improve/repair air conditioner performance must be submitted to the program.

### DEFINITION OF BASELINE EQUIPMENT

In order for this characterization to apply, the baseline condition is assumed to be an AC system that that does not have a standing maintenance contract or a tune up within in the past 36 months.

### DEEMED LIFETIME OF EFFICIENT EQUIPMENT

The expected measure life is assumed to be 3 years.<sup>580</sup>

### DEEMED MEASURE COST

Tune-up costs can vary considerably, particularly if refrigerant leak detection, remediation and recharge is necessary. Actual invoiced tune-up costs should be used.

### LOADSHAPE

Loadshape C03 - Commercial Cooling

### COINCIDENCE FACTOR

$$\begin{aligned} CF_{SSP} &= \text{Summer System Peak Coincidence Factor for Commercial cooling (during system peak hour)} \\ &= 91.3\% \text{ }^{581} \end{aligned}$$

---

<sup>580</sup>3 years is given for “Clean Condenser Coils – Commercial” and “Clean Evaporator Coils”. DEER2014 EUL Table.

<sup>581</sup> Based on analysis of Itron eShape data for Missouri, calibrated to Illinois loads, supplied by Ameren. The AC load during the utility’s peak hour is divided by the maximum AC load during the year.

$$CF_{PJM} = \text{PJM Summer Peak Coincidence Factor for Commercial cooling (average during peak period)}$$

$$= 47.8\% \text{ }^{582}$$

---



---

**Algorithm**

---

**CALCULATION OF SAVINGS**

**ELECTRIC ENERGY SAVINGS**

$$\Delta \text{kWh} = (\text{kBtu/hr}) * [(1/\text{EERbefore}) - (1/\text{EERafter})] * \text{EFLH}$$

Where:

- kBtu/hr = capacity of the cooling equipment actually installed in kBtu per hour (1 ton of cooling capacity equals 12 kBtu/hr).  
=Actual
- EERbefore = Energy Efficiency Ratio of the baseline equipment prior to tune-up<sup>583</sup>  
=Actual
- EERafter = Energy Efficiency Ratio of the baseline equipment after to tune-up  
=Actual
- EFLH = Equivalent Full Load Hours for cooling in Existing Buildings are provided in section 4.4 HVAC End Use

Where it is not possible or appropriate to perform Test in and Test out of the equipment, the following deemed methodology can be used:

$$\Delta \text{kWh} = (\text{kBtu/hr}) / \text{EERbefore} * \text{EFLH} * \% \text{Savings}$$

Where:

- %Savings = Deemed percent savings per Tune-Up component. These are additive if condenser cleaning, evaporator cleaning and refrigerant charge correction are performed (totals provided below)<sup>584</sup>

Tune-Up Component	% savings
Condenser Cleaning	6.10%
Evaporator Cleaning	0.22%
Refrig. Charge Off. <=20%	0.68%

<sup>582</sup>Based on analysis of Itron eShape data for Missouri, calibrated to Illinois loads, supplied by Ameren. The average AC load over the PJM peak period (1-5pm, M-F, June through August) is divided by the maximum AC load during the year.

<sup>583</sup> In the context of this measure Energy Efficiency Ratio (EER) refers to field-measured steady-state rate of heat energy removal (e.g., cooling capacity) by the equipment in Btuh divided by the steady-state rate of energy input to the equipment in watts. This ratio is expressed in Btuh per watt (Btuh/watt). The cooling capacity may be derived using either refrigerant or air-side measurements. The measurement is performed at the outdoor and indoor environmental conditions that are present at the time the tune-up is being performed, and should be normalized using a correction function to the AHRI 210/240 Standard test conditions. The correction function should be developed based on manufacturer’s performance data. Care must be taken to ensure the unit is fully loaded and operating at or near steady-state. Generally, this requires that the outside air temperature is at least 60°F, and that the unit runs with all stages of cooling enabled for 10 to 15 minutes prior to making measurements. For more information, please see “IL TRM\_Normalizing to AHRI Conditions Method”.

<sup>584</sup> Savings estimates are determined by applying the findings from DNV-GL “Impact Evaluation of 2013-2014 HVAC3 Commercial Quality Maintenance Programs”, April 2016, to simulate the inefficient condition within select eQuest models and across climate zones. The percent savings were consistent enough across building types and climate zones that it was determined appropriate to apply a single set of assumptions for all. See ‘eQuest C&I Tune up Analysis.xlsx’ for more information.

Tune-Up Component	% savings
Refrig. Charge Off. >20%	8.44%
Combined (Refrig. Charge Off. <=20%)	7.00%
Combined (Refrig. Charge Off. >20%)	14.76%

**For example**, a 12 EER 5-ton rooftop air conditioner on a department store in Rockford receives a tune-up that includes both condenser and evaporator cleaning:

$$\begin{aligned} \Delta kWh &= (5 \cdot 12) / 12 \cdot 1,392 \cdot 6.32\% \\ &= 440 \text{ kWh} \end{aligned}$$

**SUMMER COINCIDENT PEAK DEMAND SAVINGS**

$$\begin{aligned} \Delta kW_{SSP} &= (\text{kBtu/hr} \cdot (1/\text{EER}_{\text{before}} - 1/\text{EER}_{\text{after}})) \cdot CF_{SSP} \\ \Delta kW_{PJM} &= (\text{kBtu/hr} \cdot (1/\text{EER}_{\text{before}} - 1/\text{EER}_{\text{after}})) \cdot CF_{PJM} \end{aligned}$$

Where:

- CF<sub>SSP</sub> = Summer System Peak Coincidence Factor for Commercial cooling (during system peak hour)  
= 91.3%<sup>585</sup>
- CF<sub>PJM</sub> = PJM Summer Peak Coincidence Factor for Commercial cooling (average during peak period)  
= 47.8%<sup>586</sup>

Where it is not possible or appropriate to perform Test in and Test out of the equipment, the following deemed methodology can be used:

$$\Delta kW = (\text{kBtu/hr}) / \text{EER}_{\text{before}} \cdot \% \text{Savings} \cdot CF$$

**FOSSIL FUEL SAVINGS**

N/A

**WATER IMPACT DESCRIPTIONS AND CALCULATION**

N/A

**DEEMED O&M COST ADJUSTMENT CALCULATION**

N/A

**MEASURE CODE: CI-HVC-ACTU-V06-210101**

**REVIEW DEADLINE: 1/1/2025**

<sup>585</sup> Based on analysis of Itron eShape data for Missouri, calibrated to Illinois loads, supplied by Ameren. The AC load during the utility’s peak hour is divided by the maximum AC load during the year.

<sup>586</sup>Based on analysis of Itron eShape data for Missouri, calibrated to Illinois loads, supplied by Ameren. The average AC load over the PJM peak period (1-5pm, M-F, June through August) is divided by the maximum AC load during the year.

## 4.4.2 Space Heating Boiler Tune-up

### DESCRIPTION

This measure is for a non-residential boiler that provides space heating. The tune-up will improve boiler efficiency by cleaning and/or inspecting burners, combustion chamber, and burner nozzles. Adjust air flow and reduce excessive stack temperatures, adjust burner and gas input. Check venting, safety controls, and adequacy of combustion air intake. Combustion efficiency should be measured before and after tune-up using an electronic flue gas analyzer.

### DEFINITION OF EFFICIENT EQUIPMENT

To qualify for this measure the facility must, as applicable, complete the tune-up requirements listed below<sup>587</sup> by approved technician:

- Measure combustion efficiency using an electronic flue gas analyzer
- Adjust airflow and reduce excessive stack temperatures
- Adjust burner and gas input, manual or motorized draft control
- Check for proper venting
- Complete visual inspection of system piping and insulation
- Check safety controls
- Check adequacy of combustion air intake
- Clean fireside surfaces.
- Inspect all refractory. Patch and wash coat as required.\*
- Inspect gaskets on front and rear doors and replace as necessary.\*
- Seal and close front and rear doors properly.\*
- Clean low and auxiliary low water cut-off controls, then re-install using new gaskets.\*
- Clean plugs in control piping.\*
- Remove all hand hole and manhole plates. Flush boiler with water to remove loose scale and sediment.\*
- Replace all hand hole and manhole plates with new gaskets.\*
- Open feedwater tank manway, inspect and clean as required. Replace manway plate with new gasket.\*
- Clean burner and burner pilot.
- Check pilot electrode and adjust or replace.
- Clean air damper and blower assembly.
- Clean motor starter contacts and check operation.\*
- Make necessary adjustments to burner for proper combustion.
- Perform all flame safeguard and safety trip checks.
- Check all hand hole plates and manhole plates for leaks at normal operating temperatures and pressures.
- Troubleshoot any boiler system problems as requested by on-site personnel

Note: Tune-up activities marked with an asterisk (\*) are eligible to be performed by internal maintenance staff at periods of boiler shutdown.

### DEFINITION OF BASELINE EQUIPMENT

The baseline condition of this measure is a boiler that has not had a tune-up within the past 36 months.

---

<sup>587</sup> Act on Energy Commercial Technical Reference Manual No. 2010-4, 9.2.2 Gas Boiler Tune-up

**DEEMED LIFETIME OF EFFICIENT EQUIPMENT**

The life of this measure is 3 years.<sup>588</sup>

**DEEMED MEASURE COST**

The cost of this measure is \$0.83/MBtu/hr per tune-up<sup>589</sup>

**LOADSHAPE**

N/A

**COINCIDENCE FACTOR**

N/A

**Algorithm**

**CALCULATION OF ENERGY SAVINGS**

**ELECTRIC ENERGY SAVINGS**

N/A

**SUMMER COINCIDENT PEAK DEMAND SAVINGS**

N/A

**FOSSIL FUEL SAVINGS**

$$\Delta \text{Therms} = (\text{Capacity} * \text{EFLH} * (((\text{Eff}_{\text{before}} + E_i) / \text{Eff}_{\text{before}}) - 1)) / 100,000$$

Where:

Capacity = Boiler gas input size (Btu/hr)  
 = Custom

EFLH = Equivalent Full Load Hours for heating in Existing Buildings are provided in section 4.4 HVAC End Use

Eff<sub>before</sub> = Efficiency of the boiler before the tune-up  
 = Actual. Default value is 81.5%<sup>590</sup>

*Note: Contractors should select a mid-level firing rate that appropriately represents the average building operating condition over the course of the heating season and take readings at a consistent firing rate for pre and post tune-up.*

E<sub>i</sub> = Efficiency improvement of the boiler tune-up measure  
 = Actual. Default value is 2.3%<sup>591</sup>

<sup>588</sup> Act on Energy Commercial Technical Reference Manual No. 2010-4, 9.2.2 Gas Boiler Tune-up

<sup>589</sup> Work Paper – Tune up for Boilers serving Space Heating and Process Load by Resource Solutions Group, January 2012

<sup>590</sup> Guidehouse evaluation results from tune-up efficiency improvement research for Peoples Gas and North Shore Gas through their C&I and Public Sector Prescriptive Rebate Program, their Small Business Program, and their Multi-Family Programs. The evaluation included project and population data from program year’s 2018 and 2019.

<sup>591</sup> Guidehouse evaluation results from tune-up efficiency improvement research for Peoples Gas and North Shore Gas through their C&I and Public Sector Prescriptive Rebate Program, their Small Business Program, and their Multi-Family Programs. The evaluation included project and population data from program year’s 2018 and 2019.



100,000 = Converts Btu to therms

**For example**, a 1050 kBtu boiler in a Chicago high rise office records an efficiency prior to tune up of 81.5% AFUE and a 2.3% improvement in efficiency after tune up:

$$\begin{aligned}\Delta\text{therms} &= (1,050,000 * 2050 * ((0.815 + 0.023) / 0.815 - 1)) / 100,000 \\ &= 607 \text{ Therms}\end{aligned}$$

**SUMMER COINCIDENT PEAK DEMAND SAVINGS**

N/A

**WATER IMPACT DESCRIPTIONS AND CALCULATION**

N/A

**DEEMED O&M COST ADJUSTMENT CALCULATION**

N/A

**MEASURE CODE: CI-HVC-BLRT-V07-210101**

**REVIEW DEADLINE: 1/1/2025**

### 4.4.3 Process Boiler Tune-up

#### DESCRIPTION

This measure is for a non-residential boiler for process loads. For space heating, see measure 4.4.2. The tune-up will improve boiler efficiency by cleaning and/or inspecting burners, combustion chamber, and burner nozzles. Adjust air flow and reduce excessive stack temperatures, adjust burner and gas input. Check venting, safety controls, and adequacy of combustion air intake. Combustion efficiency should be measured before and after tune-up using an electronic flue gas analyzer.

#### DEFINITION OF EFFICIENT EQUIPMENT

To qualify for this measure the facility must, as applicable, complete the tune-up requirements by approved technician<sup>592</sup> as specified below:

- Measure combustion efficiency using an electronic flue gas analyzer
- Adjust airflow and reduce excessive stack temperatures
- Adjust burner and gas input, manual or motorized draft control
- Check for proper venting
- Complete visual inspection of system piping and insulation
- Check safety controls
- Check adequacy of combustion air intake
- Clean fireside surfaces
- Inspect all refractory. Patch and wash coat as required.\*
- Inspect gaskets on front and rear doors and replace as necessary.\*
- Seal and close front and rear doors properly.\*
- Clean low and auxiliary low water cut-off controls, then re-install using new gaskets.\*
- Clean plugs in control piping.\*
- Remove all hand hole and man hole plates. Flush boiler with water to remove loose scale and sediment.\*
- Replace all hand hole and man hole plates with new gaskets.\*
- Open feedwater tank manway, inspect and clean as required. Replace manway plate with new gasket.\*
- Clean burner and burner pilot.
- Check pilot electrode and adjust or replace.
- Clean air damper and blower assembly.
- Clean motor starter contacts and check operation.\*
- Make necessary adjustments to burner for proper combustion.
- Perform all flame safeguard and safety trip checks.
- Check all hand hole plates and man hole plates for leaks at normal operating temperatures and pressures.
- Troubleshoot any boiler system problems as requested by on-site personnel

Note: Tune-up activities marked with an asterisk (\*) are eligible to be performed by internal maintenance staff at periods of boiler shutdown.

---

<sup>592</sup> Act on Energy Commercial Technical Reference Manual No. 2010-4, 9.2.2 Gas Boiler Tune-up

**DEFINITION OF BASELINE EQUIPMENT**

The baseline condition of this measure is a boiler that has not had a tune-up within the past 24 months and that does not have a standing maintenance contract.

**DEEMED LIFETIME OF EFFICIENT EQUIPMENT**

The life of this measure is 2 year.<sup>593</sup>

**DEEMED MEASURE COST**

The cost of this measure is \$0.60/MBtu/hr per tune-up.<sup>594</sup>

**DEEMED O&M COST ADJUSTMENTS**

N/A

**LOADSHAPE**

N/A

**COINCIDENCE FACTOR**

N/A

---

**Algorithm**

---

**CALCULATION OF ENERGY SAVINGS**

**ELECTRIC ENERGY SAVINGS**

N/A

**SUMMER COINCIDENT PEAK DEMAND SAVINGS**

N/A

**FOSSIL FUEL SAVINGS**

$$\Delta\text{Therms} = ((\text{Capacity} * 8766 * \text{UF}) / 100) * (1 - (\text{Eff}_{\text{pre}} / \text{Eff}_{\text{measured}}))$$

Where:

Capacity = Boiler gas input size (kBtu/hr)

=Custom

UF = Utilization Factor

= 41.9%,<sup>595</sup> or custom

Eff<sub>pre</sub> = Boiler Combustion Efficiency Before Tune-Up

---

<sup>593</sup> U.S. Department of Energy, “Chapter 9 O&M Ideas for Major Equipment Types” in Operations & Maintenance Best Practices Guide: Release 3.0”, August 2010, 9.19 – 9.20

<sup>594</sup> Incremental costs are sourced from Nicor Gas program data and reflect an average of actual process boiler tune-up costs from projects implemented in 2020 and 2021. For more detail, see: “4.4.2 Process Boiler tune up IMC – Nicor Gas.xlsx”.

<sup>595</sup> Work Paper – Tune up for Boilers serving Space Heating and Process Load by Resource Solutions Group, January 2012

= Actual. Default value is 80.3%<sup>596</sup>

*Note: Contractors should select a firing rate that appropriately represents the average operating condition and take readings at a consistent firing rate for pre and post tune-up.*

Eff<sub>measured</sub> = Boiler Combustion Efficiency After Tune-Up

= Actual. Default value is 82.6%<sup>597</sup>

100 = conversion from kBtu to therms

8766 = hours a year

**For example**, a 80.3% 1050 kBtu boiler is tuned-up resulting in final efficiency of 82.6%:

$$\begin{aligned}\Delta\text{therms} &= ((1050 * 8766 * 0.419) / 100) * (1 - (0.80.3 / 0.826)) \\ &= 1074 \text{ therms}\end{aligned}$$

**SUMMER COINCIDENT PEAK DEMAND SAVINGS**

N/A

**WATER IMPACT DESCRIPTIONS AND CALCULATION**

N/A

**DEEMED O&M COST ADJUSTMENT CALCULATION**

N/A

**MEASURE CODE: CI-HVC-PBTU-V07-230101**

**REVIEW DEADLINE: 1/1/2026**

---

<sup>596</sup> Guidehouse evaluation results from tune-up efficiency improvement research for Peoples Gas and North Shore Gas through their C&I and Public Sector Prescriptive Rebate Program, their Small Business Program, and their Multi-Family Programs. The evaluation included project and population data from program year’s 2018 and 2019.

<sup>597</sup> Guidehouse evaluation results from tune-up efficiency improvement research for Peoples Gas and North Shore Gas through their C&I and Public Sector Prescriptive Rebate Program, their Small Business Program, and their Multi-Family Programs. The evaluation included project and population data from program year’s 2018 and 2019.

#### 4.4.4 Boiler Lockout/Reset Controls

##### DESCRIPTION

This measure relates to improving combustion efficiency by adding controls to non-residential space heating boilers to vary the boiler entering water temperature relative to heating load as a function of the outdoor air temperature to save energy. Energy is saved by increasing the temperature difference between the water temperature entering the boiler in the boiler's heat exchanger and the boiler's burner flame temperature. The flame temperature remains the same while the water temperature leaving the boiler decreases with the decrease in heating load due to an increase in outside air temperature. A lockout temperature is also set to prevent the boiler from turning on when it is above a certain temperature outdoors.

This measure was developed to be applicable to the following program types: RF. If applied to other program types, the measure savings should be verified.

##### DEFINITION OF EFFICIENT EQUIPMENT

Natural gas customer adding boiler reset controls capable of resetting the boiler supply water temperature in an inverse linear fashion with outdoor air temperature. Boiler lockout temperatures should be set to 55 °F at this time as well, to turn the boiler off when the temperature goes above a certain setpoint.

##### DEFINITION OF BASELINE EQUIPMENT

Existing boiler without boiler reset controls, any size with constant hot water flow.

##### DEEMED LIFETIME OF EFFICIENT EQUIPMENT

The life of this measure is 16 years.<sup>598</sup>

##### DEEMED MEASURE COST

The cost of this measure is \$612.<sup>599</sup>

##### LOADSHAPE

N/A

##### COINCIDENCE FACTOR

N/A

---

#### Algorithm

---

##### CALCULATION OF SAVINGS

##### ELECTRIC ENERGY SAVINGS

N/A

##### SUMMER COINCIDENT PEAK DEMAND SAVINGS

N/A

---

<sup>598</sup> This is intentionally longer than the assumptions found in the early replacement commercial HVAC measures as the application of boiler reset controls will occur in a variety of sites that may not be targeted for early replacement HVAC systems.

<sup>599</sup> Nexant. Questar DSM Market Characterization Report. August 9, 2006.

### FOSSIL FUEL SAVINGS

$$\Delta\text{Therms} = \text{Capacity}_{\text{input}} * \text{SF} * \text{EFLH} / 100$$

Where:

$\text{Capacity}_{\text{input}}$  = Boiler Input Capacity (kBtu/hr)

= custom

SF = Savings factor

= 8%,<sup>600</sup> or custom

EFLH = Equivalent Full Load Hours for heating in Existing Buildings are provided in section 4.4 HVAC End Use

100 = conversion from kBtu to therms

**For example**, reset controls were installed on an 800 kBtu/hr boiler at a restaurant in Rockford, IL

$$\begin{aligned}\Delta\text{Therms} &= 800 * 0.08 * 1,350 / 100 \\ &= 864 \text{ Therms}\end{aligned}$$

### WATER IMPACT DESCRIPTIONS AND CALCULATION

N/A

### DEEMED O&M COST ADJUSTMENT CALCULATION

N/A

**MEASURE CODE: CI-HVC-BLRC-V05-240101**

**REVIEW DEADLINE: 1/1/2029**

---

<sup>600</sup> Savings factor is the estimate of annual gas consumption that is saved due to adding boiler reset controls. A comparable savings factor, based on boiler tuneup savings is derived from Xcel Energy "DSM Biennial Plan-Technical Assumptions," Colorado. For further substantiation, Wisconsin Focus on Energy 2020 TRM uses 8%, citing multiple sources. And other prescriptive programs across the country consistently use between 5 and 10% savings factor (Efficiency Vermont - 2020, New York TRM, version 7.0 – 2020 (Cadmus Group, Inc. Home Energy Services Impact Evaluation, August 2012, pg. 20)).

## 4.4.5 Condensing Unit Heaters

### DESCRIPTION

This measure applies to a gas fired condensing unit heater installed in a commercial application.

This measure was developed to be applicable to the following program types: TOS, NC. If applied to other program types, the measure savings should be verified.

### DEFINITION OF EFFICIENT EQUIPMENT

In order for this characterization to apply, the efficient equipment is assumed to be a condensing unit heater up to 300 MBH with a Thermal Efficiency > 90% and the heater must be vented, and condensate drained per manufacturer specifications. The unit must be replacing existing natural gas equipment.

### DEFINITION OF BASELINE EQUIPMENT

In order for this characterization to apply, the baseline condition is assumed to be a non-condensing natural gas unit heater at end of life.

### DEEMED LIFETIME OF EFFICIENT EQUIPMENT

The expected measure life is assumed to be 12 years.<sup>601</sup>

### DEEMED MEASURE COST

The incremental capital cost for a unit heater is equal to the input capacity in kBtu/h multiplied by \$15.56<sup>602</sup>

Incremental cost = Capacity \* \$15.56

Where:

Capacity	= Nominal rating of the input capacity of the new condensing unit heater in kBtu/hr
\$15.56	= Incremental cost per kBtu/h of input capacity of a new condensing unit heater

### LOADSHAPE

N/A

### COINCIDENCE FACTOR

N/A

---

### Algorithm

---

### CALCULATION OF SAVINGS

#### ELECTRIC ENERGY SAVINGS

N/A

---

<sup>601</sup>DEER 2008

<sup>602</sup>The incremental capitol cost is based on historic project data from Wisconsin Focus on Energy, spanning 2015 through June 2018. The data is aggregated based on 29 projects that comprised of 100 installed unit heaters. The average installed unit heater cost was \$22.64 / kBtu/h of input unit capacity. The baseline unit heater cost was estimated to be \$7.08 / kBtu/h of input unit capacity, per review of online pricing of Reznor and Modine models on Supply House’s website. The incremental cost was sourced from the 2020 Wisconsin Focus on Energy TRM, Public Service Commission of Wisconsin, Cadmus – “Unit Heaters, > 90% Thermal Efficiency (pg. 234)

**SUMMER COINCIDENT PEAK DEMAND SAVINGS**

N/A

**FOSSIL FUEL SAVINGS**

$$\Delta\text{Therms} = ((\text{Capacity} * \text{EFLH} * \text{UF}) / 100) * (1 / \text{Eff}_{\text{Base}} - 1 / \text{Eff}_{\text{EE}})$$

Where:

Capacity = Nominal rating of the input capacity of the new condensing unit heater in kBtu/hr  
 = Actual

UF = Utilization Factor  
 = 72.5%,<sup>603</sup> or custom

Eff<sub>Base</sub> = Combustion Efficiency of the baseline unit heater  
 = Default value is 80%<sup>604</sup>

Eff<sub>EE</sub> = Combustion Efficiency of the installed unit heater  
 = Actual. Default value is 90%

100 = conversion from kBtu to therms

EFLH = Equivalent Full Load Hours for in Existing Buildings or New Construction are provided in section 4.4 HVAC End Use.

**For example**, a 150 kBtu condensing unit heater with a combustion efficiency of 90% is installed in a garage in Rockford:

$$\begin{aligned} \Delta\text{therms} &= ((150 * 985 * 0.725) / 100) * (1 / 0.80 - 1 / 0.90) \\ &= 149 \text{ therms} \end{aligned}$$

**WATER IMPACT DESCRIPTIONS AND CALCULATION**

N/A

**DEEMED O&M COST ADJUSTMENT CALCULATION**

N/A

**MEASURE CODE: CI-HVC-CUHT-V03-230101**

**REVIEW DEADLINE: 1/1/2027**

<sup>603</sup> The utilization factor accounts for the fact that unit heaters are typically over-sized. Value as sourced from the 2020 Wisconsin Focus on Energy Technical Reference Manual, Public Service Commission of Wisconsin, Cadmus – Unit Heaters, ≥ 90% Thermal Efficiency (pg. 234)

<sup>604</sup> Baseline combustion efficiency is sourced from IECC 2021 for all capacity warm-air unit heaters, gas-fired.



## 4.4.6 Electric Chiller

### DESCRIPTION

This measure relates to the installation of a new electric chiller meeting the efficiency standards presented below. This measure could relate to the replacement of an existing unit at the end of its useful life, or the installation of a new chiller or chillers in an existing building (i.e. time of sale) or new construction.

This measure was developed to be applicable to the following program types: TOS, NC. If applied to other program types, the measure savings should be verified.

### DEFINITION OF EFFICIENT EQUIPMENT

In order for this characterization to apply, the efficient equipment is assumed to exceed the efficiency requirements of the baseline defined by the program.

### DEFINITION OF BASELINE EQUIPMENT

In order for this characterization to apply, the baseline equipment is assumed to meet the minimum efficiency requirements within the IECC code in effect on the date of the building permit. As code requirements and adoption can differ from municipality to municipality, the user should verify which version of code is applicable given these constraints.

Note, users should refer to the website for the Illinois Energy Conservation Code to verify the latest adopted code.

### DEEMED LIFETIME OF EFFICIENT EQUIPMENT

The expected measure life is assumed to be 23 years.<sup>605</sup>

### DEEMED MEASURE COST

The incremental capital cost for this measure is provided below.<sup>606</sup>

Air-Cooled Chiller Incremental Costs (\$/Ton)				
Capacity (Tons)	Efficient EER			
	9.9	10.2	10.52	10.7
50	\$226	\$453	\$694	\$830
100	\$113	\$226	\$347	\$415
150	\$75	\$151	\$231	\$277
200	\$46	\$92	\$141	\$169
400	\$23	\$46	\$71	\$85

Water-Cooled Scroll/Screw Chiller Incremental Costs (\$/Ton)				
Capacity (Tons)	Efficient kW/ton			
	0.72	0.68	0.64	0.6
50	\$114	\$164	N/a	N/a
100	\$52	\$77	N/a	N/a
150	N/a	N/a	N/a	N/a
200	N/a	N/a	\$61	\$122
400	N/a	N/a	N/a	\$16

<sup>605</sup> As recommended in Navigant 'ComEd Effective Useful Life Research Report', May 2018. ([http://deeresources.com/deer0911planning/downloads/EUL\\_Summary\\_10-1-08.xls](http://deeresources.com/deer0911planning/downloads/EUL_Summary_10-1-08.xls)).

<sup>606</sup> Based on Navigant Consulting, NEEP "Incremental Cost Study Phase Two Final Report", January 2013.

Water-Cooled Centrifugal Chiller Incremental Costs (\$/Ton)			
Capacity (Tons)	Efficient kW/ton		
	0.6	0.58	0.54
100	\$62	\$99	\$172
150	\$42	\$66	\$115
200	\$31	\$49	\$86
300	N/a	N/a	\$55
600	N/a	N/a	\$22

**LOADSHAPE**

Loadshape C03 - Commercial Cooling

**COINCIDENCE FACTOR**

The summer peak coincidence factor for cooling is provided in two different ways below. The first is used to estimate peak savings during the utility peak hour and is most indicative of actual peak benefits, and the second represents the *average* savings over the defined summer peak period and is presented so that savings can be bid into PJM’s capacity market. Both values provided are based on analysis of Itron eShape data for Missouri, calibrated to Illinois loads, supplied by Ameren.

$$CF_{SSP} = \text{Summer System Peak Coincidence Factor for Commercial cooling (during system peak hour)}$$

$$= 91.3\%^{607}$$

$$CF_{PJM} = \text{PJM Summer Peak Coincidence Factor for Commercial cooling (average during peak period)}$$

$$= 47.8\%^{608}$$

---

**Algorithm**

---

**CALCULATION OF SAVINGS**

The enhanced electric energy savings calculation should be used as the primary method for more accurate energy savings, with the efficiencies calculated for the specific climate zone and building type for the chiller application. Where the calculated NPLV efficiency of the chiller at the specific conditions is unknown, the basic electric energy savings calculation can be used as a secondary method where the traditional industry-standard IPLV ratings may be more readily available.

**ELECTRIC ENERGY SAVINGS**

BASIC ELECTRIC ENERGY SAVINGS FOR WATER-COOLED CHILLERS:

$$\Delta kWh = \text{TONS} * ((IPLV_{base}) - (IPLV_{ee})) * EFLH$$

Where:

$$\text{TONS} = \text{chiller actual installed cooling capacity in tons (note: 1 ton = 12,000 Btu/hr)}$$

---

<sup>607</sup> Based on analysis of Itron eShape data for Missouri, calibrated to Illinois loads, supplied by Ameren. The AC load during the utility’s peak hour is divided by the maximum AC load during the year.

<sup>608</sup> Based on analysis of Itron eShape data for Missouri, calibrated to Illinois loads, supplied by Ameren. The average AC load over the PJM peak period (1-5pm, M-F, June through August) is divided by the maximum AC load during the year.

IPLV<sub>base</sub> = efficiency of baseline equipment expressed as Integrated Part Load Value(kW/ton) obtained from current IECC Minimum Efficiency Table – Path (A). Refer to Baseline Efficiency Values by Chiller Type and Capacity in the Reference Tables & Equations section.

IPLV<sub>ee</sub><sup>609</sup> = efficiency of high efficiency equipment expressed as Integrated Part Load Value (kW/ton)<sup>610</sup>  
 = Actual installed

EFLH = Equivalent Full Load Hours for cooling in Existing Buildings or New Construction are provided in section 4.4 HVAC End Use.

**ENHANCED ELECTRIC ENERGY SAVINGS FOR WATER-COOLED CHILLERS:**

$$\Delta kWH = TONS * ((IPLV_{base} * IL_{adj}) - (NPLV - I_{Lee})) * EFLH$$

Where:

TONS = chiller actual installed cooling capacity in tons (note: 1 ton = 12,000 Btu/hr)

IL<sub>adj</sub> = adjustment factor to align IPLV<sub>base</sub> to Illinois climate and building type. Refer to Table 1 below.

NPLV-I<sub>Lee</sub><sup>611</sup> = efficiency of proposed high efficiency equipment as Non-Standard Part Load Value (kW/ton) evaluated at Illinois adjusted conditions. All other variables to remain at AHRI standard conditions. Chiller manufacturer shall evaluate their chiller’s efficiencies at the four unique part-load operating points using entering condenser water temperatures (ECWT) and the adjusted weighted percentages from Table 2 below for the applicable building space type listed<sup>7</sup>. Refer to following NPLV equation:

$$NPLV (kw/ton) = 1/[a/A + b/B + c/C + d/D]$$

Where: the lower case letters are the decimal values for weighting and the upper case letters are the chiller efficiency rating at each unique operating point.

EFLH = Equivalent Full Load Hours for cooling in Existing Buildings or New Construction are provided in section 4.4 HVAC End Use.

**TABLE 1:**

---

<sup>609</sup> Integrated Part Load Value is a seasonal average efficiency rating calculated in accordance with ARI Standard 550/590. It may be calculated using any measure of efficiency (EER, kW/ton, COP), but for consistency with IECC code requirements, it is expressed in terms of IPLV here.

<sup>610</sup> Can determine IPLV from standard testing or looking at engineering specs for design conditions. Standard data is available from AHRI online Certification Directory.

<sup>611</sup> Calculation to be performed using manufacturer-provided efficiency ratings at custom part-load operating points specific to Illinois climate and building type. All other variables to remain at AHRI standard conditions. These custom part-load operating points are based on building load profiles generated from public domain EnergyPlus files developed by Pacific Northwest National Labs in conjunction and with oversight from ASHRAE. The different building types are reflective of certain typical occupancy schedules. See Reference Tables & Equations section at the end of this measure for additional info and supporting equations.

Water-Cooled Chillers ILadj Factors to IPLV (Path A) Baseline		
Space Type (occupancy schedule assumption)	Water-Cooled Chiller Type	
	Centrifugal	Screw/Scroll
Office (or unknown <sup>612</sup> ) (12hr, 5 days/week)	1.143	1.178
Hospital (24hr, 7 days/week, high occupancy during day)	1.043	1.067
High-Rise Apartments (24hr, 7 days/week, lighter occupancy during day)	1.117	1.155
Primary School (12hr, 5 days/week, seasonal)	1.082	1.127
Hotel (24hr, 7days/week)	1.159	1.186

**TABLE 2:**

Water-Cooled Chillers NPLV Part-Load Evaluation Conditions Adjusted to Illinois by Building Type								
Space Type	% Full Load Cooling Design for Chiller							
	25%		50%		75%		94%	
	Weight	ECWT [F]	Weight	ECWT [F]	Weight	ECWT [F]	Weight	ECWT [F]
Office (or unknown)	40.1%	68.1	38.3%	74.8	17.9%	80.4	3.7%	84.8
Hospital	15.0%	62.2	44.6%	69.8	35.6%	76.7	4.8%	83.7
High-Rise Apartments	30.1%	68.7	41.6%	73.8	21.3%	78.7	7.0%	83.4
Primary School	25.3%	67.0	26.3%	71.9	31.2%	76.1	17.2%	81.5
Hotel	47.8%	67.0	39.2%	76.1	12.2%	82.2	0.80%	86.9

**BASIC ELECTRIC ENERGY SAVINGS FOR AIR-COOLED CHILLERS:**

$$\Delta \text{kWh} = \text{TONS} * ((12/\text{IPLV}_{\text{base}}) - (12/\text{IPLV}_{\text{vee}})) * \text{EFLH}$$

Where:

TONS = chiller actual installed cooling capacity in tons (note: 1 ton = 12,000 Btu/hr)

IPLV<sub>base</sub> = efficiency of baseline equipment as Integrated Part Load Value (EER) obtained from current IECC Minimum Efficiency Table – Path (A).. Refer to Baseline Efficiency Values by Chiller Type and Capacity in the Reference Tables & Equations section.

IPLV<sub>vee</sub><sup>613</sup> = efficiency of proposed high efficiency equipment expressed as Integrated Part Load Value (EER)

<sup>612</sup> Office building type is considered a reasonable estimate of the average application.

<sup>613</sup> Integrated Part Load Value is a seasonal average efficiency rating calculated in accordance with AHRI Standard 550/590. It may be calculated using any measure of efficiency (EER, kW/ton, COP), but for consistency with IECC code requirements, it is expressed in terms of IPLV here. IPLV data is available from AHRI online Certification Directory or certified chiller manufacturer’s data.

EFLH = Equivalent Full Load Hours for cooling in Existing Buildings or New Construction are provided in section 4.4 HVAC End Use.

**ENHANCED ELECTRIC ENERGY SAVINGS FOR AIR-COOLED CHILLERS:**

$$\Delta\text{kWH} = \text{TONS} * (12/(\text{IPLV}_{\text{base}} * \text{ILadj}) - 12/(\text{NPLV-ILee})) * \text{EFLH}$$

Where:

TONS = chiller actual installed cooling capacity in tons (note: 1 ton = 12,000 Btu/hr)

ILadj = adjustment factor to align IPLV<sub>base</sub> to Illinois climate and building type. Refer to Table 3 below.

NPLV-ILee<sup>614</sup> = efficiency of proposed high efficiency equipment as Non-Standard Part Load Value (EER) evaluated at Illinois adjusted conditions. All other variables to remain at AHRI standard conditions. Chiller manufacturer shall evaluate their chiller’s efficiencies at the four unique part-load operating points using outdoor design dry bulb (ODDB) and the adjusted weighted percentages from Table 4 below for the applicable building space type listed. Refer to following NPLV equation:

$$\text{NPLV (EER)} = a*A + b*B + c*C + d*D$$

Where: the lower case letters are the decimal values for weighting and the upper case letters are the chiller efficiency rating at each unique operating point.

EFLH = Equivalent Full Load Hours for cooling in Existing Buildings or New Construction are provided in section 4.4 HVAC End Use.

**TABLE 3:**

Air-Cooled Chillers ILadj Factors to IPLV (Path A) Baseline	
Space Type	Air-Cooled Chiller
Office (or unknown)	0.860
Hospital	0.925
High-Rise Apartments	0.866
Primary School	0.850
Hotel	0.929

**TABLE 4:**

Air-Cooled Chillers NPLV Part-Load Evaluation Conditions Adjusted to Illinois by Building Type								
Space Type	% Full Load Cooling Design for Chiller							
	25%		50%		75%		94%	
	Weight	ODDB [F]	Weight	ODDB [F]	Weight	ODDB [F]	Weight	ODDB [F]
Office (or unknown)	40.1%	69.1	38.3%	77.2	17.9%	83.9	3.7%	89.2

<sup>614</sup> Calculation to be performed using manufacturer-provided efficiency ratings at custom part-load operating points specific to Illinois climate and building type. All other variables to remain at AHRI standard conditions. These custom part-load operating points are based on building load profiles generated from public domain EnergyPlus files developed by Pacific Northwest National Labs in conjunction and with oversight from ASHRAE. The different building types are reflective of certain typical occupancy schedules. See Reference Tables & Equations section at the end of this measure for additional info and supporting equations.

Air-Cooled Chillers								
NPLV Part-Load Evaluation Conditions Adjusted to Illinois by Building Type								
Space Type	% Full Load Cooling Design for Chiller							
	25%		50%		75%		94%	
	Weight	ODDB [F]	Weight	ODDB [F]	Weight	ODDB [F]	Weight	ODDB [F]
Hospital	15.0%	60.0	44.6%	70.2	35.6%	77.5	4.8%	86.6
High-Rise Apartments	30.1%	67.2	41.6%	75.9	21.3%	83.2	7.0%	89
Primary School	25.3%	68.1	26.3%	74.1	31.2%	79.6	17.2%	85.6
Hotel	47.8%	65.3	39.2%	76.9	12.2%	84.6	0.80%	85.6

**SUMMER COINCIDENT PEAK DEMAND SAVINGS**

$$\Delta kW_{SSP} = \text{TONS} * ((PE_{base}) - (PE_{ee})) * CF_{SSP}$$

$$\Delta kW_{PJM} = \text{TONS} * ((PE_{base}) - (PE_{ee})) * CF_{PJM}$$

Where:

PE<sub>base</sub> = Peak efficiency of baseline equipment expressed as Full Load (kW/ton)

PE<sub>ee</sub> = Peak efficiency of high efficiency equipment expressed as Full Load (kW/ton)

= Actual installed

CF<sub>SSP</sub> = Summer System Peak Coincidence Factor for Commercial cooling (during system peak hour)

= 91.3%

CF<sub>PJM</sub> = PJM Summer Peak Coincidence Factor for Commercial cooling (average during peak period)

= 47.8%

**FOSSIL FUEL SAVINGS**

N/A

**WATER IMPACT DESCRIPTIONS AND CALCULATION**

N/A

**DEEMED O&M COST ADJUSTMENT CALCULATION**

N/A

**REFERENCE TABLES**

\*Chillers Ratings- Chillers are rated with different units depending on equipment type as shown below

Equipment Type	Unit
Air cooled, electrically operated	Full load EER Part Load EER
Water cooled, electrically operated, positive displacement (reciprocating and rotary screw and scroll)	Full Load kW/ton Part Load kW/ton

Equipment Type	Unit
Water cooled, electrically operated, centrifugal	Full Load kW/ton Part Load kW/ton

**\*\*IPLV Equations and Standard Rating Conditions per AHRI 550/590:**

Expression Of Chiller Efficiency	Equation
Coefficient Of Performance–COP, W/W, or Energy Efficiency Ratio–EER, Btu/h/W	$IPLV \text{ or } NPLV = 0.01A + 0.42B + 0.45C + 0.12D$
Power Per Ton, kW/ton	$IPLV \text{ or } NPLV = \frac{1}{\frac{0.01}{A} + \frac{0.42}{B} + \frac{0.45}{C} + \frac{0.12}{D}}$
Chiller Energy Efficiency, Load	
	<b>A</b> at 100% <b>B</b> at 75% <b>C</b> at 50% <b>D</b> at 25%    — at 0%
IPLV Rating Conditions	
Condenser, water-cooled only: <sup>a</sup>	
Entering water temperature, F [C]	85 [29.4] <sup>b</sup> 75 [23.9]    65 [18.3]    65 [18.3]    65 [18.3]
Flow rate, gpm/ton [Lps per kW]	3.0 [0.054] <sup>c</sup>
Fouling factor, h-ft <sup>2</sup> -F/Btu [m <sup>2</sup> -C/W]	0.00025 [0.000044]
Evaporator:	
Leaving water temperature, F [C]	44 [6.7] <sup>b</sup> —    —    —    44 [6.7]
Flow rate, gpm/ton [Lps per kW]	2.4 [0.043] <sup>c</sup> —    —    —    2.4 [0.043]
Fouling factor, h-ft <sup>2</sup> -F/Btu [m <sup>2</sup> -C/W]	0.0001[0.000018]

**\*\*\*Building Types - Generalized Occupancy Schedules of Building Types for Reference:**

Office –12 hour operation; 5 days a week

Hospital –24 hour operation; 7 days a week; heavier occupancy during the day

High Rise Apts – 24 hour operation; 7 days a week; lighter occupancy during the day

Primary School – 12 hour operation; 5 days a week; seasonal

Hotel –24 hour operation; 7 days a week

**\*\*\*\*Conversion Factors – Equations to convert efficiency units where necessary:**

kW/ton = 12 / EER

kW/ton = 12 / (COP x 3.412)

COP = EER / 3.412

COP = 12 / (kW/ton) / 3.412

EER = 12 / kW/ton

EER = COP x 3.412

2018 IECC Baseline Efficiency Values by Chiller Type and Capacity (effective 7/1/2019 to 12/31/2022)

TABLE C403.3.2(7)  
WATER CHILLING PACKAGES — EFFICIENCY REQUIREMENTS<sup>a, b, c, d</sup>

EQUIPMENT TYPE	SIZE CATEGORY	UNITS	BEFORE 1/1/2015		AS OF 1/1/2015		TEST PROCEDURE <sup>e</sup>	
			Path A	Path B	Path A	Path B		
Air-cooled chillers	< 150 Tons	EER (Btu/W)	≥ 9.562 FL	NA <sup>c</sup>	≥ 10.100 FL	≥ 9.700 FL	AHRI 550/590	
			≥ 12.500 IPLV		≥ 13.700 IPLV	≥ 15.800 IPLV		
	≥ 150 Tons		≥ 9.562 FL	NA <sup>c</sup>	≥ 10.100 FL	≥ 9.700 FL		
			≥ 12.500 IPLV		≥ 14.000 IPLV	≥ 16.100 IPLV		
Air cooled without condenser, electrically operated	All capacities	EER (Btu/W)	Air-cooled chillers without condenser shall be rated with matching condensers and complying with air-cooled chiller efficiency requirements.					
Water cooled, electrically operated positive displacement	< 75 Tons	kW/ton	≤ 0.780 FL	≤ 0.800 FL	≤ 0.750 FL	≤ 0.780 FL		AHRI 550/590
	≥ 75 tons and < 150 tons		≤ 0.630 IPLV	≤ 0.600 IPLV	≤ 0.600 IPLV	≤ 0.500 IPLV		
			≤ 0.775 FL	≤ 0.790 FL	≤ 0.720 FL	≤ 0.750 FL		
	≥ 150 tons and < 300 tons		≤ 0.615 IPLV	≤ 0.588 IPLV	≤ 0.560 IPLV	≤ 0.490 IPLV		
			≥ 0.680 FL	≥ 0.718 FL	≥ 0.660 FL	≥ 0.680 FL		
	≥ 300 tons and < 600 tons		≤ 0.580 IPLV	≥ 0.540 IPLV	≥ 0.540 IPLV	≥ 0.440 IPLV		
			≤ 0.620 FL	≤ 0.639 FL	≤ 0.610 FL	≤ 0.625 FL		
	≥ 600 tons		≤ 0.540 IPLV	≤ 0.490 IPLV	≤ 0.520 IPLV	≤ 0.410 IPLV		
≤ 0.620 FL		≤ 0.639 FL	≤ 0.560 FL	≤ 0.585 FL				
Water cooled, electrically operated centrifugal	< 150 Tons	kW/ton	≤ 0.634 FL	≤ 0.639 FL	≤ 0.610 FL	≤ 0.695 FL	AHRI 560	
	≥ 150 tons and < 300 tons		≤ 0.596 IPLV	≤ 0.450 IPLV	≤ 0.550 IPLV	≤ 0.440 IPLV		
			≤ 0.634 FL	≤ 0.639 FL	≤ 0.610 FL	≤ 0.635 FL		
	≥ 300 tons and < 400 tons		≤ 0.596 IPLV	≤ 0.450 IPLV	≤ 0.550 IPLV	≤ 0.400 IPLV		
			≤ 0.576 FL	≤ 0.600 FL	≤ 0.560 FL	≤ 0.595 FL		
	≥ 400 tons and < 600 tons		≤ 0.549 IPLV	≤ 0.400 IPLV	≤ 0.520 IPLV	≤ 0.390 IPLV		
			≤ 0.576 FL	≤ 0.600 FL	≤ 0.560 FL	≤ 0.585 FL		
	≥ 600 Tons		≤ 0.549 IPLV	≤ 0.400 IPLV	≤ 0.500 IPLV	≤ 0.380 IPLV		
≤ 0.570 FL		≤ 0.590 FL	≤ 0.560 FL	≤ 0.585 FL				
Air cooled, absorption, single effect	All capacities	COP	≥ 0.600 FL	NA <sup>c</sup>	≥ 0.600 FL	NA <sup>c</sup>	AHRI 560	
Water cooled absorption, single effect	All capacities	COP	≥ 0.700 FL	NA <sup>c</sup>	≥ 0.700 FL	NA <sup>c</sup>		
Absorption, double effect, indirect fired	All capacities	COP	≥ 1.000 FL	NA <sup>c</sup>	≥ 1.000 FL	NA <sup>c</sup>		
			≥ 1.050 IPLV		≥ 1.050 IPLV			
Absorption double effect direct fired	All capacities	COP	≥ 1.000 FL	NA <sup>c</sup>	≥ 1.000 FL	NA <sup>c</sup>		
			≥ 1.000 IPLV		≥ 1.050 IPLV			

a. The requirements for centrifugal chiller shall be adjusted for nonstandard rating conditions in accordance with Section C403.3.2.1 and are only applicable for the range of conditions listed in Section C403.3.2.1. The requirements for air-cooled, water-cooled positive displacement and absorption chillers are at standard rating conditions defined in the reference test procedure.  
 b. Both the full-load and IPLV requirements shall be met or exceeded to comply with this standard. Where there is a Path B, compliance can be with either Path A or Path B for any application.  
 c. NA means the requirements are not applicable for Path B and only Path A can be used for compliance.  
 d. FL represents the full-load performance requirements and IPLV the part-load performance requirements.



2021 IECC Baseline Efficiency Values by Chiller Type and Capacity (CURRENT)

**TABLE C403.3.2(3)**  
**WATER-CHILLING PACKAGES—MINIMUM EFFICIENCY REQUIREMENTS<sup>a, b, c, f</sup>**

EQUIPMENT TYPE	SIZE CATEGORY	UNITS	PATH A	PATH B	TEST PROCEDURE <sup>e</sup>
Air cooled chillers	< 150 tons	EER (Btu/Wh)	≥ 10.100 FL	≥ 9.700 FL	AHRI 550/590
			≥ 13.700 IPLV.IP	≥ 15.800 IPLV.IP	
	≥ 150 tons		≥ 10.100 FL	≥ 9.700FL	
			≥ 14.000 IPLV.IP	≥ 16.100 IPLV.IP	
Air cooled without condenser, electrically operated	All capacities	EER (Btu/Wh)	Air-cooled chillers without condenser must be rated with matching condensers and comply with air-cooled chiller efficiency requirements		AHRI 550/590
Water cooled, electrically operated positive displacement	< 75 tons	kW/ton	≤ 0.750 FL	≤ 0.780 FL	AHRI 550/590
			≤ 0.600 IPLV.IP	≤ 0.500 IPLV.IP	
	≥ 75 tons and < 150 tons		≤ 0.720 FL	≤ 0.750 FL	
			≤ 0.560 IPLV.IP	≤ 0.490 IPLV.IP	
	≥ 150 tons and < 300 tons		≤ 0.660 FL	≤ 0.680 FL	
			≤ 0.540 IPLV.IP	≤ 0.440 IPLV.IP	
	≥ 300 tons and < 600 tons		≤ 0.610 FL	≤ 0.625 FL	
			≤ 0.520 IPLV.IP	≤ 0.410 IPLV.IP	
≥ 600 tons	≤ 0.560 FL	≤ 0.585 FL			
		≤ 0.500 IPLV.IP	≤ 0.380 IPLV.IP		
Water cooled, electrically operated centrifugal	< 150 tons	kW/ton	≤ 0.610 FL	≤ 0.695 FL	AHRI 550/590
			≤ 0.550 IPLV.IP	≤ 0.440 IPLV.IP	
	≥ 300 tons and < 400 tons		≤ 0.610 FL	≤ 0.635 FL	
			≤ 0.550 IPLV.IP	≤ 0.400 IPLV.IP	
	≥ 400 tons and < 600 tons		≤ 0.560 FL	≤ 0.595 FL	
			≤ 0.520 IPLV.IP	≤ 0.390 IPLV.IP	
	≥ 600 tons		≤ 0.560 FL	≤ 0.585 FL	
			≤ 0.500 IPLV.IP	≤ 0.380 IPLV.IP	
		≤ 0.560 FL	≤ 0.585 FL		
		≤ 0.500 IPLV.IP	≤ 0.380 IPLV.IP		
Air cooled absorption, single effect	All capacities	COP (W/W)	≥ 0.600 FL	NA <sup>d</sup>	AHRI 560
Water cooled absorption, single effect	All capacities	COP (W/W)	≥ 0.700 FL	NA <sup>d</sup>	AHRI 560
Absorption double effect, indirect fired	All capacities	COP (W/W)	≥ 1.000 FL	NA <sup>d</sup>	AHRI 560
			≥ 0.150 IPLV.IP		
Absorption double effect, direct fired	All capacities	COP (W/W)	≥ 1.000 FL	NA <sup>d</sup>	AHRI 560
			≥ 1.000 IPLV		

- a. Chapter 6 contains a complete specification of the referenced standards, which include test procedures, including the reference year version of the test procedure.
- b. The requirements for centrifugal chillers shall be adjusted for nonstandard rating conditions per Section C403.3.2.1 and are applicable only for the range of conditions listed there. The requirements for air-cooled, water-cooled positive displacement and absorption chillers are at standard rating conditions defined in the reference test procedure.
- c. Both the full-load and IPLV.IP requirements must be met or exceeded to comply with this standard. When there is a Path B, compliance can be with either Path A or Path B for any application.
- d. NA means the requirements are not applicable for Path B, and only Path A can be used for compliance.
- e. FL is the full-load performance requirements, and IPLV.IP is for the part-load performance requirements.
- f. This table is a replica of ASHRAE 90.1 Table 6.8.1-3 Water-Chilling Packages—Minimum Efficiency Requirements.

**MEASURE CODE: CI-HVC-CHIL-V09-240101**

**REVIEW DEADLINE: 1/1/2028**

#### 4.4.7 ENERGY STAR and CEE Tier 2 Room Air Conditioner

##### DESCRIPTION

This measure relates to the purchase and installation of a room air conditioning unit that meets either the ENERGY STAR or CEE Tier 2 minimum qualifying efficiency specifications, in place of a baseline unit meeting minimum Federal Standard efficiency ratings presented below.<sup>615</sup>

Product Class (Btu/H)	Federal Standard CEER, with louvered sides	Federal Standard CEER, without louvered sides	ENERGY STAR CEER, with louvered sides	ENERGY STAR CEER, without louvered sides	CEE Tier 2 CEER
< 8,000	11.0	10.0	12.1	11.0	12.7
8,000 to 10,999	10.9	9.6	12.0	10.6	12.5
11,000 to 13,999		9.5		10.5	
14,000 to 19,999	10.7	9.3	11.8	10.2	12.3
20,000 to 27,999	9.4	9.4	10.3	10.3	10.8
>= 28,000	9.0		9.9		10.4

Casement	Federal Standard (CEER)	ENERGY STAR (CEER)
Casement-only	9.5	10.5
Casement-slider	10.4	11.4

Reverse Cycle - Product Class (Btu/H)	Federal Standard CEER, with louvered sides	Federal Standard CEER, without louvered sides	ENERGY STAR CEER, with louvered sides	ENERGY STAR CEER, without louvered sides
< 14,000	N/A	9.3	N/A	10.2
>= 14,000	N/A	8.7	N/A	9.6
< 20,000	9.8	N/A	10.8	N/A
>= 20,000	9.3	N/A	10.2	N/A

This measure was developed to be applicable to the following program types: TOS. If applied to other program types, the measure savings should be verified.

##### DEFINITION OF EFFICIENT EQUIPMENT

To qualify for this measure the new room air conditioning unit must meet the ENERGY STAR efficiency standards presented above.

<sup>615</sup> Federal Baselines defined by Code of Federal Regulations §430.32(d). ENERGY STAR specification defined by Version 4.0 Room Air Conditioners. CEE specification defined by Room Air Conditioner Specification effective January 31, 2017. Side louvers that extend from a room air conditioner model in order to position the unit in a window. A model without louvered sides is placed in a built-in wall sleeve and are commonly referred to as "through-the-wall" or "built-in" models. Casement-only refers to a room air conditioner designed for mounting in a casement window of a specific size. Casement-slider refers to a room air conditioner with an encased assembly designed for mounting in a sliding or casement window of a specific size. Reverse cycle refers to the heating function found in certain room air conditioner models.

**DEFINITION OF BASELINE EQUIPMENT**

The baseline assumption is a new room air conditioning unit that meets the current minimum federal efficiency standards presented above.

**DEEMED LIFETIME OF EFFICIENT EQUIPMENT**

The measure life is assumed to be 12 years.<sup>616</sup>

**DEEMED MEASURE COST**

The incremental cost for this measure is assumed to be \$40 for an ENERGY STAR unit and \$100 for a CEE Tier 2 unit.<sup>617</sup>

**LOADSHAPE**

Loadshape C03 - Commercial Cooling

**COINCIDENCE FACTOR**

The summer peak coincidence factor for cooling is provided in two different ways below. The first is used to estimate peak savings during the utility peak hour and is most indicative of actual peak benefits, and the second represents the *average* savings over the defined summer peak period, and is presented so that savings can be bid into PJM’s capacity market. Both values provided are based on analysis of Itron eShape data for Missouri, calibrated to Illinois loads, supplied by Ameren.

$$CF_{SSP} = \text{Summer System Peak Coincidence Factor for Commercial cooling (during system peak hour)} \\ = 91.3\% \text{ }^{618}$$

$$CF_{PJM} = \text{PJM Summer Peak Coincidence Factor for Commercial cooling (average during peak period)} \\ = 47.8\% \text{ }^{619}$$

---

**Algorithm**

---

**CALCULATION OF SAVINGS**

**ENERGY SAVINGS**

$$\Delta kWh = (FLH_{RoomAC} * Btu/h * (1/CEER_{base} - 1/CEER_{ee}))/1000$$

Where:

- FLH<sub>RoomAC</sub> = Full Load Hours of room air conditioning unit  
= Equivalent Full Load Hours for cooling in Existing Buildings are provided in section 4.4 HVAC End Use
- Btu/h = Input capacity of unit  
= Actual. If unknown assume 8,500 Btu/hr<sup>620</sup>

---

<sup>616</sup> Measure Life Report, Residential and Commercial/Industrial Lighting and HVAC Measures, GDS Associates, June 2007.

<sup>617</sup> CEE Tier 1 cost based on field study conducted by Efficiency Vermont and Tier 2 based on professional judgement.

<sup>618</sup> Based on analysis of Itron eShape data for Missouri, calibrated to Illinois loads, supplied by Ameren. The AC load during the utility’s peak hour is divided by the maximum AC load during the year.

<sup>619</sup> Based on analysis of Itron eShape data for Missouri, calibrated to Illinois loads, supplied by Ameren. The average AC load over the PJM peak period (1-5pm, M-F, June through August) is divided by the maximum AC load during the year

<sup>620</sup> Based on maximum capacity average from the RLW Report: Final Report Coincidence Factor Study Residential Room Air Conditioners, June 23, 2008.

CEER<sub>base</sub> = Combined Energy Efficiency Ratio of baseline unit  
 = As provided in tables above

CEER<sub>ee</sub> = Combined Energy Efficiency Ratio of ENERGY STAR or CEE Super Efficient unit  
 = Actual. If unknown assume minimum qualifying standard as provided in tables above

**For example**, for an 8,500 Btu/h capacity ENERGY STAR unit, with louvered sides, in a unknown location in Rockford:

$$\begin{aligned} \Delta\text{kWh}_{\text{ENERGY STAR}} &= (1133 * 8500 * (1/10.9 - 1/12.0)) / 1000 \\ &= 81.0 \text{ kWh} \end{aligned}$$

**SUMMER COINCIDENT PEAK DEMAND SAVINGS**

$$\Delta\text{kW} = \text{Btu/h} * ((1/\text{CEER}_{\text{base}} - 1/\text{CEER}_{\text{ee}})/1000) * \text{CF}$$

Where:

CF<sub>SSP</sub> = Summer System Peak Coincidence Factor for Commercial cooling (during system peak hour)  
 = 91.3%<sup>621</sup>

CF<sub>PJM</sub> = PJM Summer Peak Coincidence Factor for Commercial cooling (average during peak period)  
 = 47.8%<sup>622</sup>

Other variable as defined above

For example, for an 8,500 Btu/h capacity ENERGY STAR unit, with louvered sides, in Rockford during system peak

$$\begin{aligned} \Delta\text{kW}_{\text{ENERGY STAR}} &= (8500 * (1/10.9 - 1/12.0)) / 1000 * 0.913 \\ &= 0.065 \text{ kW} \end{aligned}$$

**FOSSIL FUEL SAVINGS**

N/A

**WATER IMPACT DESCRIPTIONS AND CALCULATION**

N/A

**DEEMED O&M COST ADJUSTMENT CALCULATION**

N/A

**MEASURE CODE: CI-HVC-ESRA-V03-220101**

**REVIEW DEADLINE: 1/1/2025**

<sup>621</sup> Based on analysis of Itron eShape data for Missouri, calibrated to Illinois loads, supplied by Ameren. The AC load during the utility’s peak hour is divided by the maximum AC load during the year.

<sup>622</sup> Based on analysis of Itron eShape data for Missouri, calibrated to Illinois loads, supplied by Ameren. The average AC load over the PJM peak period (1-5pm, M-F, June through August) is divided by the maximum AC load during the year.

## 4.4.8 Guest Room Energy Management (PTAC & PTHP)

### DESCRIPTION

This measure applied to the installation of a temperature setback and lighting control system for individual guest rooms. The savings are achieved based on Guest Room Energy Management's (GREM's) ability to automatically adjust the guest room's set temperatures and control the HVAC unit for various occupancy modes.

This measure was developed to be applicable to the following program types: TOS, NC. If applied to other program types, the measure savings should be verified.

### DEFINITION OF EFFICIENT EQUIPMENT

Guest room temperature set point must be controlled by automatic occupancy detectors or keycard that indicates the occupancy status of the room. During unoccupied periods the default setting for controlled units differs by at least 5 degrees from the operating set point. Theoretically, the control system may also be tied into other electric loads, such as lighting and plug loads to shut them off when occupancy is not sensed. This measure bases savings on improved HVAC controls. If system is connected to lighting and plug loads, additional savings would be realized. The incentive is per guestroom controlled, rather than per sensor, for multi-room suites. Replacement or upgrades of existing occupancy-based controls are not eligible for an incentive.

### DEFINITION OF BASELINE EQUIPMENT

Guest room energy management thermostats replace manual heating/cooling temperature set-point and fan On/Off/Auto thermostat controls. Two possible baselines exist based on whether housekeeping staff are directed to set-back (or turn off) thermostats when rooms are not rented.

### DEEMED LIFETIME OF EFFICIENT EQUIPMENT

The measure life for GREM is 15 years.<sup>623</sup>

### DEEMED MEASURE COST

\$260/unit.

The incremental cost documented for this measure is \$260 per room HVAC controller, which is the cost difference between a non-programmable thermostat and a GREM.<sup>624</sup>

### DEEMED O&M COST ADJUSTMENTS

N/A

### LOADSHAPE

Loadshape C03 - Commercial Cooling

### COINCIDENCE FACTOR

A coincidence factor is not used in the determination of coincident peak kW savings.

---

<sup>623</sup> DEER 2008 value for energy management systems.

<sup>624</sup> This value was extracted from Smart Ideas projects in PY1 and PY2.

**Algorithm**

**CALCULATION OF SAVINGS**

Below are the annual kWh savings per installed EMS for different sizes and types of HVAC units. The savings are achieved based on GREM’s ability to automatically adjust the guest room’s set temperatures and control the HVAC unit to maintain set temperatures for various occupancy modes. Note that care should be taken in selecting a value consistent with actual baseline conditions (e.g., whether housekeeping staff are directed to set-back/turn-off the thermostats when rooms are unrented). Different values are provided for Motels and Hotels since significant differences in shell performance, number of external walls per room and typical heating and cooling efficiencies result in significantly different savings estimates. Energy savings estimates are derived using a prototypical EnergyPlus simulation of a motel and a hotel.<sup>625</sup> Model outputs are normalized to the installed capacity and reported here as kWh/Ton, coincident peak kW/Ton and Therms/Ton.

**ELECTRIC ENERGY SAVINGS**

Climate Zone (City based upon)	Heating Source	Baseline	Electric Savings (kWh/Ton)
<b>Motel Electric Energy Savings</b>			
1 (Rockford)	PTAC w/ Electric Resistance Heating	Housekeeping Setback	744
		No Housekeeping Setback	1,786
	PTAC w/ Gas Heating	Housekeeping Setback	63
		No Housekeeping Setback	155
	PTHP	Housekeeping Setback	385
		No Housekeeping Setback	986
2 (Chicago)	PTAC w/ Electric Resistance Heating	Housekeeping Setback	506
		No Housekeeping Setback	1,582
	PTAC w/ Gas Heating	Housekeeping Setback	51
		No Housekeeping Setback	163
	PTHP	Housekeeping Setback	211
		No Housekeeping Setback	798
3 (Springfield)	PTAC w/ Electric Resistance Heating	Housekeeping Setback	462
		No Housekeeping Setback	1,382
	PTAC w/ Gas Heating	Housekeeping Setback	65
		No Housekeeping Setback	198
	PTHP	Housekeeping Setback	202
		No Housekeeping Setback	736
4 (Belleville)	PTAC w/ Electric Resistance Heating	Housekeeping Setback	559
		No Housekeeping Setback	1,877
	PTAC w/ Gas Heating	Housekeeping Setback	85
		No Housekeeping Setback	287
	PTHP	Housekeeping Setback	260
		No Housekeeping Setback	1,023
5 (Marion-Williamson)	PTAC w/ Electric Resistance Heating	Housekeeping Setback	388
		No Housekeeping Setback	1,339
	PTAC w/ Gas Heating	Housekeeping Setback	81

<sup>625</sup> For motels, see S. Keates, ADM Associates Workpaper: “Suggested Revisions to Guest Room Energy Management (PTAC & PTHP)”, 11/14/2013 and spreadsheet summarizing the results: ‘GREM Savings Summary\_IL TRM\_1\_22\_14.xlsx’. In 2014 the hotel models were also run to compile results, rather than by applying adjustment factors to the motel results as had been done in V3.0 of the TRM. The updated values can be found in ‘GREM Savings Summary (Hotel)\_IL TRM\_10\_16\_14.xls’.

Climate Zone (City based upon)	Heating Source	Baseline	Electric Savings (kWh/Ton)
	PTHP	No Housekeeping Setback	274
		Housekeeping Setback	174
		No Housekeeping Setback	682
<b>Hotel Electric Energy Savings</b>			
1 (Rockford)	PTAC w/ Electric Resistance Heating	Housekeeping Setback	204
		No Housekeeping Setback	345
	PTAC w/ Gas Heating	Housekeeping Setback	121
		No Housekeeping Setback	197
	PTHP	Housekeeping Setback	152
		No Housekeeping Setback	253
	Central Hot Water Fan Coil w/ Electric Resistance Heating	Housekeeping Setback	177
		No Housekeeping Setback	296
	Central Hot Water Fan Coil w/ Gas Heating	Housekeeping Setback	94
		No Housekeeping Setback	148
2 (Chicago)	PTAC w/ Electric Resistance Heating	Housekeeping Setback	188
		No Housekeeping Setback	342
	PTAC w/ Gas Heating	Housekeeping Setback	119
		No Housekeeping Setback	195
	PTHP	Housekeeping Setback	145
		No Housekeeping Setback	250
	Central Hot Water Fan Coil w/ Electric Resistance Heating	Housekeeping Setback	161
		No Housekeeping Setback	294
	Central Hot Water Fan Coil w/ Gas Heating	Housekeeping Setback	92
		No Housekeeping Setback	147
3 (Springfield)	PTAC w/ Electric Resistance Heating	Housekeeping Setback	182
		No Housekeeping Setback	291
	PTAC w/ Gas Heating	Housekeeping Setback	123
		No Housekeeping Setback	197
	PTHP	Housekeeping Setback	145
		No Housekeeping Setback	233
	Central Hot Water Fan Coil w/ Electric Resistance Heating	Housekeeping Setback	153
		No Housekeeping Setback	240
	Central Hot Water Fan Coil w/ Gas Heating	Housekeeping Setback	94
		No Housekeeping Setback	146
4 (Belleville)	PTAC w/ Electric Resistance Heating	Housekeeping Setback	182
		No Housekeeping Setback	308
	PTAC w/ Gas Heating	Housekeeping Setback	125
		No Housekeeping Setback	199
	PTHP	Housekeeping Setback	146
		No Housekeeping Setback	240
	Central Hot Water Fan Coil w/ Electric Resistance Heating	Housekeeping Setback	152
		No Housekeeping Setback	255
	Central Hot Water Fan Coil w/ Gas Heating	Housekeeping Setback	95
		No Housekeeping Setback	147
5 (Marion-Williamson)	PTAC w/ Electric Resistance Heating	Housekeeping Setback	171
		No Housekeeping Setback	295
	PTAC w/ Gas Heating	Housekeeping Setback	122
		No Housekeeping Setback	199

Climate Zone (City based upon)	Heating Source	Baseline	Electric Savings (kWh/Ton)
	PTHP	Housekeeping Setback	140
		No Housekeeping Setback	235
	Central Hot Water Fan Coil w/ Electric Resistance Heating	Housekeeping Setback	141
		No Housekeeping Setback	243
	Central Hot Water Fan Coil w/ Gas Heating	Housekeeping Setback	92
		No Housekeeping Setback	146

**SUMMER COINCIDENT PEAK DEMAND SAVINGS**

Motel Coincident Peak Demand Savings			
Climate Zone (City based upon)	Heating Source	Baseline	Coincident Peak Demand Savings (kW/Ton)
1 (Rockford)	PTAC w/ Electric Resistance Heating	Housekeeping Setback	0.08
		No Housekeeping Setback	0.17
	PTAC w/ Gas Heating	Housekeeping Setback	0.08
		No Housekeeping Setback	0.17
	PTHP	Housekeeping Setback	0.08
		No Housekeeping Setback	0.17
2 (Chicago)	PTAC w/ Electric Resistance Heating	Housekeeping Setback	0.06
		No Housekeeping Setback	0.17
	PTAC w/ Gas Heating	Housekeeping Setback	0.06
		No Housekeeping Setback	0.17
	PTHP	Housekeeping Setback	0.06
		No Housekeeping Setback	0.17
3 (Springfield)	PTAC w/ Electric Resistance Heating	Housekeeping Setback	0.07
		No Housekeeping Setback	0.17
	PTAC w/ Gas Heating	Housekeeping Setback	0.07
		No Housekeeping Setback	0.17
	PTHP	Housekeeping Setback	0.07
		No Housekeeping Setback	0.17
4 (Belleville)	PTAC w/ Electric Resistance Heating	Housekeeping Setback	0.10
		No Housekeeping Setback	0.28
	PTAC w/ Gas Heating	Housekeeping Setback	0.10
		No Housekeeping Setback	0.28
	PTHP	Housekeeping Setback	0.10
		No Housekeeping Setback	0.28
5 (Marion-Williamson)	PTAC w/ Electric Resistance Heating	Housekeeping Setback	0.08
		No Housekeeping Setback	0.21
	PTAC w/ Gas Heating	Housekeeping Setback	0.08
		No Housekeeping Setback	0.21
	PTHP	Housekeeping Setback	0.08
		No Housekeeping Setback	0.21



Hotel Coincident Peak Demand Savings			
Climate Zone (City based upon)	Heating Source	Baseline	Coincident Peak Demand Savings (kW/Ton)
1 (Rockford)	PTAC w/ Electric Resistance Heating	Housekeeping Setback	0.08
		No Housekeeping Setback	0.11
	PTAC w/ Gas Heating	Housekeeping Setback	0.08
		No Housekeeping Setback	0.11
	PTHP	Housekeeping Setback	0.08
		No Housekeeping Setback	0.11
	Central Hot Water Fan Coil w/ Electric Resistance Heating	Housekeeping Setback	0.05
		No Housekeeping Setback	0.08
	Central Hot Water Fan Coil w/ Gas Heating	Housekeeping Setback	0.05
		No Housekeeping Setback	0.08
2 (Chicago)	PTAC w/ Electric Resistance Heating	Housekeeping Setback	0.07
		No Housekeeping Setback	0.11
	PTAC w/ Gas Heating	Housekeeping Setback	0.07
		No Housekeeping Setback	0.11
	PTHP	Housekeeping Setback	0.07
		No Housekeeping Setback	0.11
	Central Hot Water Fan Coil w/ Electric Resistance Heating	Housekeeping Setback	0.05
		No Housekeeping Setback	0.07
	Central Hot Water Fan Coil w/ Gas Heating	Housekeeping Setback	0.05
		No Housekeeping Setback	0.07
3 (Springfield)	PTAC w/ Electric Resistance Heating	Housekeeping Setback	0.08
		No Housekeeping Setback	0.11
	PTAC w/ Gas Heating	Housekeeping Setback	0.08
		No Housekeeping Setback	0.11
	PTHP	Housekeeping Setback	0.08
		No Housekeeping Setback	0.11
	Central Hot Water Fan Coil w/ Electric Resistance Heating	Housekeeping Setback	0.05
		No Housekeeping Setback	0.07
	Central Hot Water Fan Coil w/ Gas Heating	Housekeeping Setback	0.05
		No Housekeeping Setback	0.07
4 (Belleville)	PTAC w/ Electric Resistance Heating	Housekeeping Setback	0.08
		No Housekeeping Setback	0.11
	PTAC w/ Gas Heating	Housekeeping Setback	0.08
		No Housekeeping Setback	0.11
	PTHP	Housekeeping Setback	0.08
		No Housekeeping Setback	0.11
	Central Hot Water Fan Coil w/ Electric Resistance Heating	Housekeeping Setback	0.05
		No Housekeeping Setback	0.08
	Central Hot Water Fan Coil w/ Gas Heating	Housekeeping Setback	0.05
		No Housekeeping Setback	0.08
5 (Marion-Williamson)	PTAC w/ Electric Resistance Heating	Housekeeping Setback	0.08
		No Housekeeping Setback	0.11
	PTAC w/ Gas Heating	Housekeeping Setback	0.08
		No Housekeeping Setback	0.11
	PTHP	Housekeeping Setback	0.08
		No Housekeeping Setback	0.11

Hotel Coincident Peak Demand Savings			
Climate Zone (City based upon)	Heating Source	Baseline	Coincident Peak Demand Savings (kW/Ton)
	Central Hot Water Fan Coil w/ Electric Resistance Heating	Housekeeping Setback	0.05
		No Housekeeping Setback	0.08
	Central Hot Water Fan Coil w/ Gas Heating	Housekeeping Setback	0.05
		No Housekeeping Setback	0.08

**FOSSIL FUEL SAVINGS**

For PTACs with gas heating:

Motel Natural Gas Energy Savings		
Climate Zone (City based upon)	Baseline	Gas Savings (Therms/Ton)
1 (Rockford)	Housekeeping Setback	30
	No Housekeeping Setback	71
2 (Chicago)	Housekeeping Setback	20
	No Housekeeping Setback	62
3 (Springfield)	Housekeeping Setback	17
	No Housekeeping Setback	52
4 (Belleville)	Housekeeping Setback	21
	No Housekeeping Setback	70
5 (Marion-Williamson)	Housekeeping Setback	13
	No Housekeeping Setback	47

Hotel Natural Gas Energy Savings			
Climate Zone (City based upon)	Heating Source	Baseline	Gas Savings (Therms/Ton)
1 (Rockford)	PTAC w/ Gas Heating	Housekeeping Setback	3.6
		No Housekeeping Setback	6.4
	Central Hot Water Fan Coil w/ Gas Heating	Housekeeping Setback	3.6
		No Housekeeping Setback	6.4
2 (Chicago)	PTAC w/ Gas Heating	Housekeeping Setback	3.0
		No Housekeeping Setback	6.5
	Central Hot Water Fan Coil w/ Gas Heating	Housekeeping Setback	3.0
		No Housekeeping Setback	6.5
3 (Springfield)	PTAC w/ Gas Heating	Housekeeping Setback	2.6
		No Housekeeping Setback	4.1
	Central Hot Water Fan Coil w/ Gas Heating	Housekeeping Setback	2.6
		No Housekeeping Setback	4.1
4 (Belleville)	PTAC w/ Gas Heating	Housekeeping Setback	2.5
		No Housekeeping Setback	4.8
	Central Hot Water Fan Coil w/ Gas Heating	Housekeeping Setback	2.5
		No Housekeeping Setback	4.8
5 (Marion-Williamson)	PTAC w/ Gas Heating	Housekeeping Setback	2.1
		No Housekeeping Setback	4.2

Hotel Natural Gas Energy Savings			
Climate Zone (City based upon)	Heating Source	Baseline	Gas Savings (Therms/Ton)
	Central Hot Water Fan Coil w/ Gas Heating	Housekeeping Setback	2.1
		No Housekeeping Setback	4.2

**WATER IMPACT DESCRIPTIONS AND CALCULATION**

N/A

**DEEMED O&M COST ADJUSTMENT CALCULATION**

N/A

**MEASURE CODE: CI-HVC-GREM-V06-0601**

**REVIEW DEADLINE: 1/1/2026**

## 4.4.9 Air and Water Source Heat Pump Systems

### DESCRIPTION

This measure applies to the installation of high-efficiency air cooled and water source heat pump systems. This measure could apply to replacing an existing unit at the end of its useful life, or installation of a new unit in a new or existing building.

This measure was developed to be applicable to the following program types: TOS, NC, EREP. If applied to other program types, the measure savings should be verified.

### DEFINITION OF EFFICIENT EQUIPMENT

In order for this characterization to apply, the efficient equipment is assumed to be a high-efficiency air cooled or water source, heat pump system that exceeds the baseline and meets program requirements.

### DEFINITION OF BASELINE EQUIPMENT

**New construction / Time of Sale:** To calculate savings with an electric baseline, the baseline equipment is assumed to be a standard-efficiency air cooled or water source heat pump system that meets the Code energy efficiency requirements (IECC or Code of Federal Regulations whichever is higher) in effect on the date of equipment purchase (if date unknown assume current Code minimum). The rating conditions for the baseline and efficient equipment efficiencies must be equivalent.

To calculate savings with a furnace/ AC baseline, the baseline equipment is assumed to meet the Code energy efficiency requirements (IECC or Code of Federal Regulations whichever is higher).

Where unknown, the baseline should be determined via EM&V and the algorithms are provided to allow savings to be calculated from any baseline condition.

In order for this characterization to apply, the baseline equipment is assumed to meet the efficiency requirements within the IECC code in effect on the date of the building permit. As code requirements and adoption can differ from municipality to municipality, the user should verify which version of code is applicable given these constraints.

Note, IECC 2021 is expected to become effective statewide in 2023. IECC 2018 is the requisite code for any projects with permitting dates spanning July 1, 2019 to the IECC 2021 effective date. Prior to July 1, 2019, IECC 2015 is the applicable code. If evaluation determines the applicable version of code, given location and timing, isn't an appropriate baseline due to supply constraints, low compliance, or other issues, the previous iteration of code may be used through 2023.

IECC 2021 leverages new DOE testing methods and associated metrics. The following conversion factors are recommended for use if the efficient equipment is not rated under the new testing procedure but the stipulated baseline is:<sup>626</sup>

$$\text{SEER2} = X * \text{SEER}$$

$$\text{EER2} = X * \text{EER}$$

$$\text{HSPF2} = X * \text{HSPF}$$

Where:

X	SEER2	EER2	HSPF2
Ducted	0.95	0.95	0.85
Ductless	1.00	1.00	0.90

<sup>626</sup> Consortium for Energy Efficiency (CEE), Testing, Testing, M1, 2, 3, Transitioning to New Federal Minimum Standards, CEE Summer Program Meeting, August, 2022.

X	SEER2	EER2	HSPF2
Packaged	0.95	0.95	0.84

Note: new Federal Standards affecting heat pumps and air conditioning equipment became effective January 1, 2023.

**Early replacement / Retrofit:** The baseline for this measure is the efficiency of the *existing* heating and cooling equipment for the assumed remaining useful life of the existing unit and a new baseline heating and cooling system meeting the code energy efficiency requirements (IECC or Code of Federal Regulations whichever is higher) for the remainder of the measure life.

**DEEMED LIFETIME OF EFFICIENT EQUIPMENT**

The expected measure life is assumed to be 16 years.<sup>627</sup>

Remaining life of existing equipment is assumed to be 6 years for ASHP and Central AC, 6 years for furnace, 8 years for boilers<sup>628</sup> and 16 years for electric resistance.<sup>629</sup>

**DEEMED MEASURE COST**

New Construction and Time of Sale: For analysis purposes, the incremental capital cost for this measure is assumed as \$100 per ton for air-cooled units.<sup>630</sup> The incremental cost for all other equipment types should be determined on a site-specific basis.

Early Replacement: The actual full installation cost of the Heat Pump (including any necessary electrical or distribution upgrades required) should be used. The assumed deferred cost of replacing existing equipment with a new baseline unit should also be incorporated.

**LOADSHAPE**

Loadshape C05 - Commercial Electric Heating and Cooling

**COINCIDENCE FACTOR**

The summer peak coincidence factor for cooling is provided in two different ways below. The first is used to estimate peak savings during the utility peak hour and is most indicative of actual peak benefits, and the second represents the *average* savings over the defined summer peak period, and is presented so that savings can be bid into PJM’s capacity market. Both values provided are based on analysis of Itron eShape data for Missouri, calibrated to Illinois loads, supplied by Ameren.

$$CF_{SSP} = \text{Summer System Peak Coincidence Factor for Commercial cooling (during system peak hour)}$$

$$= 91.3\% \text{ }^{631}$$

$$CF_{PJM} = \text{PJM Summer Peak Coincidence Factor for Commercial cooling (average during peak period)}$$

<sup>627</sup> Consistent with Residential measure and based on 2016 DOE Rulemaking Technical Support document, as recommended in Guidehouse ‘ComEd Effective Useful Life Research Report’, May 2018.

<sup>628</sup> Assumed to be one third of effective useful life of replaced equipment.

<sup>629</sup> Assume full measure life (16 years) for replacing electric resistance as we would not expect that resistance heat would fail during the lifetime of the efficient measure.

<sup>630</sup> Based on a review of TRM incremental cost assumptions from Vermont, Wisconsin, and California.

<sup>631</sup> Based on analysis of Itron eShape data for Missouri, calibrated to Illinois loads, supplied by Ameren. The AC load during the utility’s peak hour is divided by the maximum AC load during the year.

$$= 47.8\%^{632}$$

---



---

**Algorithm**

---



---

**CALCULATION OF SAVINGS**

**ELECTRIC ENERGY SAVINGS**

Non fuel switch measures:

For units with cooling capacities less than 65 kBtu/hr:

$$\begin{aligned} \Delta kWh &= \text{Annual kWh Savings}_{\text{cool}} + \text{Annual kWh Savings}_{\text{heat}} \\ \text{Annual kWh Savings}_{\text{cool}} &= (\text{Capacity}_{\text{cool}} * \text{EFLH}_{\text{cool}} * (1/\text{SEER2}_{\text{base}} - 1/(\text{SEER2}_{\text{ee}})))/1000 \\ \text{Annual kWh Savings}_{\text{heat}} &= (\text{HeatLoad} * (1/(\text{HSPF2}_{\text{base}} * \text{HSPF2}_{\text{ClimateAdj}}) - 1/(\text{HSPF2}_{\text{ee}} * \text{HSPF2}_{\text{ClimateAdj}})))/1000 \end{aligned}$$

For units with cooling capacities equal to or greater than 65 kBtu/hr:

$$\begin{aligned} \Delta kWh &= \text{Annual kWh Savings}_{\text{cool}} + \text{Annual kWh Savings}_{\text{heat}} \\ \text{Annual kWh Savings}_{\text{cool}} &= (\text{Capacity}_{\text{cool}} * \text{EFLH}_{\text{cool}} * (1/\text{IEER}_{\text{base}} - 1/\text{IEER}_{\text{ee}}))/1000 \\ \text{Annual kWh Savings}_{\text{heat}} &= (\text{HeatLoad}/3412 * (1/\text{COP}_{\text{base}} - 1/\text{COP}_{\text{ee}})) \end{aligned}$$

Fuel switch measures:

Fuel switch measures must produce positive total lifecycle energy savings (i.e., reduction in Btus at the premises) in order to qualify. This is determined as follows (note for early replacement measures the lifetime savings should be calculated by calculating savings for the remaining useful life of the existing equipment and for the remaining measure life):

$$\text{SiteEnergySavings (MMBTUs)} = \text{FuelSwitchSavings} + \text{NonFuelSwitchSavings}$$

$$\text{FuelSwitchSavings} = \text{GasHeatReplaced} - \text{HPSiteHeatConsumed}$$

$$\text{NonFuelSwitchSavings} = \text{FurnaceFanSavings} + \text{HPSiteCoolingImpact}$$

$$\text{GasHeatReplaced} = (\text{HeatLoad} * 1/\text{AFUE}_{\text{base}}) / 1,000,000$$

$$\text{FurnaceFanSavings} = (\text{FurnaceFlag} * \text{HeatLoad} * 1/\text{AFUE}_{\text{base}} * F_e) / 1,000,000$$

For units with cooling capacities less than 65 kBtu/hr:

$$\text{HPSiteHeatConsumed} = ((\text{HeatLoad} * (1/(\text{HSPF2}_{\text{ee}} * \text{HSPF2}_{\text{ClimateAdj}})))/1000 * 3412) / 1,000,000$$

$$\text{HPSiteCoolingImpact} = (\text{EFLH}_{\text{cool}} * \text{Capacity}_{\text{cool}} * (1/\text{SEER2}_{\text{base}} - 1/(\text{SEER2}_{\text{ee}})))/1000 * 3412 / 1,000,000$$

For units with cooling capacities greater than 65 kBtu/hr:

$$\text{HPSiteHeatConsumed} = (\text{HeatLoad} * (1/\text{COP}_{\text{ee}})) / 1,000,000$$

$$\text{HPSiteCoolingImpact} = (\text{EFLH}_{\text{cool}} * \text{Capacity}_{\text{cool}} * (1/\text{IEER}_{\text{base}} - 1/\text{IEER}_{\text{ee}}))/1000 * 3412 / 1,000,000$$

---

<sup>632</sup> Based on analysis of Itron eShape data for Missouri, calibrated to Illinois loads, supplied by Ameren. The average AC load over the PJM peak period (1-5pm, M-F, June through August) is divided by the maximum AC load during the year.

If SiteEnergySavings calculated above is positive, the measure is eligible.

The appropriate savings claim is dependent on which utilities are supporting the measure as provided in a table below:

Measure supported by:	Electric Utility claims (kWh):	Gas Utility claims (therms):
Electric utility only	SiteEnergySavings * 1,000,000/3,412	N/A
Electric and gas utility (Note utilities may make alternative agreements to how savings are allocated as long as total MMBtu savings remains the same).	%IncentiveElectric * SiteEnergySavings * 1,000,000/3,412	%IncentiveGas * SiteEnergySavings * 10
Gas utility only	N/A	SiteEnergySavings * 10

Note for Early Replacement measures, the efficiency terms of the existing unit should be used for the remaining useful life of the existing equipment (6 years for ASHP and Central AC, 6 years for furnace, 8 years for boilers, 15 years for electric resistance), and the efficiency terms for a new baseline unit should be used for the remaining years of the measure. See assumptions below.

Where:

Capacity<sub>cool</sub> = input capacity of the cooling equipment in Btu per hour (1 ton of cooling capacity equals 12,000 Btu/hr).

= Actual installed

SEER<sub>2base</sub> = Seasonal Energy Efficiency Ratio of the baseline equipment

= SEER from tables below, based on the applicable Code on the date of equipment purchase (if unknown assume current Code).

SEER<sub>2ee</sub> = Seasonal Energy Efficiency Ratio of the energy efficient equipment.

= Actual installed

EFLH<sub>cool</sub> = Equivalent Full Load Hours for cooling in Existing Buildings or New Construction are provided in section 4.4 HVAC End Use.

HSPF<sub>2base</sub> = Heating Seasonal Performance Factor of the baseline equipment

= HSPF from tables below, based on the applicable Code on the date of equipment purchase (if unknown assume a blended baseline value of 5.1 HSPF<sub>2</sub><sup>633</sup>).

HSPF<sub>2ee</sub> = Heating Seasonal Performance Factor of the energy efficient equipment.

= Actual installed. If rating is COP, HSPF = COP \* 3.413

HSPF\_ClimateAdj = Adjustment factor to account for observed discrepancy between seasonal heating performance relative to rated HSPF as provided by standard AHRI 210/240 rating conditions. Note, the adjustment is dependent on the test method use for the rating (i.e. HSPF or HSPF<sub>2</sub> rating)<sup>634</sup>:

<sup>633</sup> Blended Baseline value came from percentage of accounts with heat pumps (40.17%) at 7.5 HSPF<sub>2</sub> and electric furnaces (59.83%) at 3.41 HSPF as reported in the ComEd Baseline Study August 14, 2020.

<sup>634</sup> Adjustment factors are based on findings from NEEA, July 2020 'EXP07:19 Load-based and Climate-Specific Testing and Rating Procedures for Heat Pumps and Air Conditioners'. See 'NEEA HP data' for calculation. Findings were consistent with other

City (county based upon)	HSPF_ClimateAdj When using HSPF2 rating
1 (Rockford)	77%
2 (Chicago)	77%
3 (Springfield)	91%
4 (Belleville)	91%
5 (Marion)	91%
Weighted Average <sup>635</sup>	
ComEd	77%
Ameren	89%
Statewide	80%

- IEER<sub>base</sub> = Integrated Energy Efficiency Ratio of the baseline equipment  
 = IEER (or EER2) from tables below, based on the applicable Code on the date of equipment purchase (if unknown assume current Code). For air-cooled units < 65 kBtu/hr, assume the following conversion from SEER2 to EER2 for calculation of peak savings:<sup>636</sup>
- $$EER2 = (-0.02 * SEER2^2) + (1.12 * SEER2)$$
- IEER<sub>ee</sub> = Integrated Energy Efficiency Ratio (or EER2) of the energy efficient equipment. For air-cooled units < 65 kBtu/hr, if the actual EER2<sub>ee</sub> is unknown, assume the conversion from SEER2 to EER2 as provided above.  
 = Actual installed
- HeatLoad = Calculated heat load for the building  
 = EFLH<sub>heat</sub> \* Capacity<sub>heat</sub>
- EFLH<sub>heat</sub> = heating mode equivalent full load hours in Existing Buildings or New Construction are provided in section 4.4 HVAC End Use.
- Capacity<sub>heat</sub> = output capacity of the heat pump equipment in Btu per hour.  
 = Actual installed
- 3412 = Btu per kWh.
- COP<sub>base</sub> = coefficient of performance of the baseline equipment  
 = COP from tables below, based on the applicable Code on the date of equipment purchase (if unknown assume current Code). If rating is HSPF2, COP = HSPF2 / 3.413
- COP<sub>ee</sub> = coefficient of performance of the energy efficient equipment.  
 = Actual installed. If rating is HSPF2, COP = HSPF2 / 3.413

reviewed sources including ASHRAE, 2020 'Right-Sizing Electric Heat Pump and Auxiliary Heating for Residential Heating Systems Based on Actual Performance Associated with Climate Zone' and Cadmus, 2022 'Residential ccASHP Building Electrification Study'. The difference between HSPF and HSPF2 ratings is based on the change in testing procedure that will correct for some of this effect where ducted systems will have an approximately 9% lower HSPF2 rating as compared to HSPF, based on CEE presentation, July 2022, 'Testing Testing, M1, 2, 3: Transitioning to New Federal Minimum Standards'.

<sup>635</sup> Weighting for Ameren is based on electric heat accounts in each of the heating zones. Weighting for ComEd and Statewide average is based on number of occupied residential housing units in each zone. ComEd is weighted average of Zones 1-2. Alternative program-weighted assumptions can be used if appropriate.

<sup>636</sup> Based on Wassmer, M. (2003). A Component-Based Model for Residential Air Conditioner and Heat Pump Energy Calculations. Masters Thesis, University of Colorado at Boulder. Note this is appropriate for single speed units only.



AFUE<sub>base</sub> = Baseline Annual Fuel Utilization Efficiency Rating. For early replacement measures, use actual AFUE rating for the remaining useful life of the existing equipment (6 years for furnace, 8 years for boilers). For new systems (time of sale, new construction or remaining years of early replacement), use appropriate code level efficiency.

FurnaceFlag = 1 if system replaced is a gas furnace, 0 if not.

F<sub>e</sub> = Furnace Fan energy consumption as a percentage of annual fuel consumption  
 = 7.7%<sup>637</sup>

%IncentiveElectric = % of total incentive paid by electric utility  
 = Actual

%IncentiveGas = % of total incentive paid by gas utility  
 = Actual

**Code of Federal Redulations (baseline effective 1/1/2019):<sup>638</sup>**

Equipment type	Cooling capacity	Heating type	Cooling Efficiency level	Heating Efficiency level	Compliance date
Small Commercial Packaged Air Conditioning and Heating Equipment (Air-Cooled)	≥65,000 Btu/h and <135,000 Btu/h	Electric Resistance Heating or No Heating	IEER = 12.2 IEER = 14.1	N/A	1/1/2018 1/1/2024
		All Other Types of Heating	IEER = 12.0 IEER = 13.9	COP = 3.3 COP = 3.4	1/1/2018 1/1/2024
Large Commercial Packaged Air Conditioning and Heating Equipment (Air-Cooled)	≥135,000 Btu/h and <240,000 Btu/h	Electric Resistance Heating or No Heating	IEER = 11.6 IEER = 13.5	N/A	1/1/2018 1/1/2024
		All Other Types of Heating	IEER = 11.4 IEER = 13.3	COP = 3.2 COP = 3.3	1/1/2018 1/1/2024
Very Large Commercial Packaged Air Conditioning and Heating Equipment (Air-Cooled)	≥240,000 Btu/h and <760,000 Btu/h	Electric Resistance Heating or No Heating	IEER = 10.6 IEER = 12.5	N/A	1/1/2018 1/1/2024
		All Other Types of Heating	IEER = 10.4 IEER = 12.3	COP = 3.2	1/1/2018 1/1/2024
Small Commercial Package Air-Conditioning and Heating Equipment (Air-Cooled, Single-Phase, Split-System)	<65,000 Btu/h	All	SEER2 = 14.3 EER2 = 9.4	HSPF2 = 7.5	1/1/2023
Small Commercial Package Air-Conditioning and Heating Equipment (Air-Cooled, Single-Phase, Single-Package)	<65,000Btu/h	All	SEER2 = 13.4 EER2 = 8.8	HSPF2 = 6.7	1/1/2023
Small Commercial Package Air-Conditioning and Heating Equipment (Air-Cooled, 3-Phase, Split-System)	<65,000 Btu/h	All	SEER2 = 14.3 EER2 = 9.4	HSPF2 = 7.5	1/1/2025

<sup>637</sup> F<sub>e</sub> is estimated using TRM models for the three most popular building types for programmable thermostats: low-rise office (10.2%), sit-down restaurant (8.6%), and retail – strip mall (4.4%). 7.7% reflects the average Fe of the three building types. See “Fan Energy Factor Example Calculation 2021-06-23.xlsx” for reference.

<sup>638</sup> Code of Federal Regulations: Table 3 to §431.97—Updates to the Minimum Cooling Efficiency Standards for Air Conditioning and Heating Equipment and Table 4 to §431.97—Updates to the Minimum Heating Efficiency Standards for Air-Cooled Air Conditioning and Heating Equipment [Heat Pumps]. For 1/1/2024 compliance dates, note these manufacturing and import federal standards go into effect on 1/1/2023. The measure characterization is recommending delaying adopting these standards until 1/1/2024.

Equipment type	Cooling capacity	Heating type	Cooling Efficiency level	Heating Efficiency level	Compliance date
Small Commercial Package Air-Conditioning and Heating Equipment (Air-Cooled, 3-Phase, Single-Package)	<65,000Btu/h	All	SEER2 = 13.4 EER2 = 8.8	HSPF2 = 6.7	1/1/2025
Small Commercial Packaged Air-Conditioning and Heating Equipment (Water Source: Water-to-Air, Water-Loop)	<17,000 Btu/h	All	EER = 12.2	COP = 4.3	10/9/2015
	≥17,000 Btu/h and <65,000 Btu/h	All	EER = 13.0	COP = 4.3	10/9/2015
	≥65,000 Btu/h and <135,000Btu/h	All	EER = 13.0	COP = 4.3	10/9/2015

Minimum Efficiency Requirements: 2015 IECC (baseline effective 1/1/2016 to 6/30/2019)

TABLE C403.2.3(2)  
 MINIMUM EFFICIENCY REQUIREMENTS:  
 ELECTRICALLY OPERATED UNITARY AND APPLIED HEAT PUMPS

EQUIPMENT TYPE	SIZE CATEGORY	HEATING SECTION TYPE	SUBCATEGORY OR RATING CONDITION	MINIMUM EFFICIENCY		TEST PROCEDURE <sup>a</sup>	
				Before 1/1/2016	As of 1/1/2016		
Air cooled (cooling mode)	< 65,000 Btu/h <sup>b</sup>	All	Split System	13.0 SEER <sup>c</sup>	14.0 SEER <sup>c</sup>	AHRI 210/240	
			Single Package	13.0 SEER <sup>c</sup>	14.0 SEER <sup>c</sup>		
Through-the-wall, air cooled	≤ 30,000 Btu/h <sup>b</sup>	All	Split System	12.0 SEER	12.0 SEER		
			Single Package	12.0 SEER	12.0 SEER		
Single-duct high-velocity air cooled	< 65,000 Btu/h <sup>b</sup>	All	Split System	11.0 SEER	11.0 SEER		
Air cooled (cooling mode)	≥ 65,000 Btu/h and < 135,000 Btu/h	Electric Resistance (or None)	Split System and Single Package	11.0 EER 11.2 IEER	11.0 EER 12.0 IEER		AHRI 340/360
		All other	Split System and Single Package	10.8 EER 11.0 IEER	10.8 EER 11.8 IEER		
	≥ 135,000 Btu/h and < 240,000 Btu/h	Electric Resistance (or None)	Split System and Single Package	10.6 EER 10.7 IEER	10.6 EER 11.6 IEER		
		All other	Split System and Single Package	10.4 EER 10.5 IEER	10.4 EER 11.4 IEER		
	≥ 240,000 Btu/h	Electric Resistance (or None)	Split System and Single Package	9.5 EER 9.6 IEER	9.5 EER 10.6 IEER		
		All other	Split System and Single Package	9.3 EER 9.4 IEER	9.3 EER 9.4 IEER		
Water to Air: Water Loop (cooling mode)	< 17,000 Btu/h	All	86°F entering water	12.2 EER	12.2 EER	ISO 13256-1	
	≥ 17,000 Btu/h and < 65,000 Btu/h	All	86°F entering water	13.0 EER	13.0 EER		
	≥ 65,000 Btu/h and < 135,000 Btu/h	All	86°F entering water	13.0 EER	13.0 EER		
Water to Air: Ground Water (cooling mode)	< 135,000 Btu/h	All	59°F entering water	18.0 EER	18.0 EER	ISO 13256-1	
Brine to Air: Ground Loop (cooling mode)	< 135,000 Btu/h	All	77°F entering water	14.1 EER	14.1 EER	ISO 13256-1	
Water to Water: WaterLoop (cooling mode)	< 135,000 Btu/h	All	86°F entering water	10.6 EER	10.6 EER	ISO 13256-2	
Water to Water: Ground Water (cooling mode)	< 135,000 Btu/h	All	59°F entering water	16.3 EER	16.3 EER		
Brine to Water: Ground Loop (cooling mode)	< 135,000 Btu/h	All	77°F entering fluid	12.1 EER	12.1 EER		

(continued)

TABLE C403.2.3(2)—continued  
 MINIMUM EFFICIENCY REQUIREMENTS:  
 ELECTRICALLY OPERATED UNITARY AND APPLIED HEAT PUMPS

EQUIPMENT TYPE	SIZE CATEGORY	HEATING SECTION TYPE	SUBCATEGORY OR RATING CONDITION	MINIMUM EFFICIENCY		TEST PROCEDURE <sup>a</sup>
				Before 1/1/2016	As of 1/1/2016	
Air cooled (heating mode)	< 65,000 Btu/h <sup>b</sup>	—	Split System	7.7 HSPF <sup>c</sup>	8.2 HSPF <sup>c</sup>	AHRI 210/240
		—	Single Package	7.7 HSPF <sup>c</sup>	8.0 HSPF <sup>c</sup>	
Through-the-wall, (air cooled, heating mode)	≤ 30,000 Btu/h <sup>b</sup> (cooling capacity)	—	Split System	7.4 HSPF	7.4 HSPF	
		—	Single Package	7.4 HSPF	7.4 HSPF	
Small-duct high velocity (air cooled, heating mode)	< 65,000 Btu/h <sup>b</sup>	—	Split System	6.8 HSPF	6.8 HSPF	
Air cooled (heating mode)	≥ 65,000 Btu/h and < 135,000 Btu/h (cooling capacity)	—	47°F db/43°F wb outdoor air	3.3 COP	3.3 COP	
			17°F db/15°F wb outdoor air	2.25 COP	2.25 COP	
	≥ 135,000 Btu/h (cooling capacity)	—	47°F db/43°F wb outdoor air	3.2 COP	3.2 COP	
			17°F db/15°F wb outdoor air	2.05 COP	2.05 COP	
Water to Air: Water Loop (heating mode)	< 135,000 Btu/h (cooling capacity)	—	68°F entering water	4.3 COP	4.3 COP	ISO 13256-1
Water to Air: Ground Water (heating mode)	< 135,000 Btu/h (cooling capacity)	—	50°F entering water	3.7 COP	3.7 COP	
Brine to Air: Ground Loop (heating mode)	< 135,000 Btu/h (cooling capacity)	—	32°F entering fluid	3.2 COP	3.2 COP	
Water to Water: Water Loop (heating mode)	< 135,000 Btu/h (cooling capacity)	—	68°F entering water	3.7 COP	3.7 COP	ISO 13256-2
Water to Water: Ground Water (heating mode)	< 135,000 Btu/h (cooling capacity)	—	50°F entering water	3.1 COP	3.1 COP	
Brine to Water: Ground Loop (heating mode)	< 135,000 Btu/h (cooling capacity)	—	32°F entering fluid	2.5 COP	2.5 COP	

For SI: 1 British thermal unit per hour = 0.2931 W, °C = [(°F) - 32]/1.8.

- a. Chapter 6 contains a complete specification of the referenced test procedure, including the reference year version of the test procedure.
- b. Single-phase, air-cooled air conditioners less than 65,000 Btu/h are regulated by NAECA. SEER values are those set by NAECA.
- c. Minimum efficiency as of January 1, 2015.

Minimum Efficiency Requirements: 2018 IECC (baseline effective 7/1/2019 to 9/30/2022)

TABLE C403.3.2(2)  
MINIMUM EFFICIENCY REQUIREMENTS: ELECTRICALLY OPERATED UNITARY AND APPLIED HEAT PUMPS

EQUIPMENT TYPE	SIZE CATEGORY	HEATING SECTION TYPE	SUBCATEGORY OR RATING CONDITION	MINIMUM EFFICIENCY	TEST PROCEDURE <sup>a</sup>
Air cooled (cooling mode)	< 65,000 Btu/h <sup>b</sup>	All	Split System	14.0 SEER	AHRI 210/240
			Single Package	14.0 SEER	
Through-the-wall, air cooled	≤ 30,000 Btu/h <sup>b</sup>	All	Split System	12.0 SEER	
			Single Package	12.0 SEER	
Single-duct high-velocity air cooled	< 65,000 Btu/h <sup>b</sup>	All	Split System	11.0 SEER	
Air cooled (cooling mode)	≥ 65,000 Btu/h and < 135,000 Btu/h	Electric Resistance (or None)	Split System and Single Package	11.0 EER 12.0 IEER	
		All other	Split System and Single Package	10.8 EER 11.8 IEER	
	≥ 135,000 Btu/h and < 240,000 Btu/h	Electric Resistance (or None)	Split System and Single Package	10.6 EER 11.6 IEER	
		All other	Split System and Single Package	10.4 EER 11.4 IEER	
	≥ 240,000 Btu/h	Electric Resistance (or None)	Split System and Single Package	9.5 EER 10.6 IEER	
		All other	Split System and Single Package	9.3 EER 9.4 IEER	
Water to Air: Water Loop (cooling mode)	< 17,000 Btu/h	All	86°F entering water	12.2 EER	ISO 13256-1
	≥ 17,000 Btu/h and < 65,000 Btu/h	All	86°F entering water	13.0 EER	
	≥ 65,000 Btu/h and < 135,000 Btu/h	All	86°F entering water	13.0 EER	
Water to Air: Ground Water (cooling mode)	< 135,000 Btu/h	All	59°F entering water	18.0 EER	ISO 13256-1
Brine to Air: Ground Loop (cooling mode)	< 135,000 Btu/h	All	77°F entering water	14.1 EER	ISO 13256-1
Water to Water: Water Loop (cooling mode)	< 135,000 Btu/h	All	86°F entering water	10.6 EER	ISO 13256-2
Water to Water: Ground Water (cooling mode)	< 135,000 Btu/h	All	59°F entering water	16.3 EER	
Brine to Water: Ground Loop (cooling mode)	< 135,000 Btu/h	All	77°F entering fluid	12.1 EER	

**IECC2018 Table C403.3.2(2) continued from previous page:**

Air cooled (heating mode)	< 65,000 Btu/h <sup>b</sup>	—	Split System	8.2 HSPF	AHRI 210/240
		—	Single Package	8.0 HSPF	
Through-the-wall, (air cooled, heating mode)	≤ 30,000 Btu/h <sup>b</sup> (cooling capacity)	—	Split System	7.4 HSPF	
		—	Single Package	7.4 HSPF	
Small-duct high velocity (air cooled, heating mode)	< 65,000 Btu/h <sup>b</sup>	—	Split System	6.8 HSPF	
Air cooled (heating mode)	≥ 65,000 Btu/h and < 135,000 Btu/h (cooling capacity)	—	47°F db/43°F wb outdoor air	3.3 COP	
		—	17°Fdb/15°F wb outdoor air	2.25 COP	
	≥ 135,000 Btu/h (cooling capacity)	—	47°F db/43°F wb outdoor air	3.2 COP	
		—	17°Fdb/15°F wb outdoor air	2.05 COP	
Water to Air: Water Loop (heating mode)	< 135,000 Btu/h (cooling capacity)	—	68°F entering water	4.3 COP	ISO 13256-1
Water to Air: Ground Water (heating mode)	< 135,000 Btu/h (cooling capacity)	—	50°F entering water	3.7 COP	
Brine to Air: Ground Loop (heating mode)	< 135,000 Btu/h (cooling capacity)	—	32°F entering fluid	3.2 COP	
Water to Water: Water Loop (heating mode)	< 135,000 Btu/h (cooling capacity)	—	68°F entering water	3.7 COP	ISO 13256-2
Water to Water: Ground Water (heating mode)	< 135,000 Btu/h (cooling capacity)	—	50°F entering water	3.1 COP	
Brine to Water: Ground Loop (heating mode)	< 135,000 Btu/h (cooling capacity)	—	32°F entering fluid	2.5 COP	

For SI: 1 British thermal unit per hour = 0.2931 W, °C = [(°F) - 32]/1.8.

- a. Chapter 6 contains a complete specification of the referenced test procedure, including the reference year version of the test procedure.
- b. Single-phase, air-cooled heat pumps less than 65,000 Btu/h are regulated by NAECA. SEER and HSPF values are those set by NAECA.

Minimum Efficiency Requirements: 2021 IECC (baseline effective 10/1/2022 for New Construction measures)

TABLE C403.3.2(2)  
ELECTRICALLY OPERATED AIR-COOLED UNITARY HEAT PUMPS—MINIMUM EFFICIENCY REQUIREMENTS<sup>a, d</sup>

EQUIPMENT TYPE	SIZE CATEGORY	HEADING SECTION TYPE	SUBCATEGORY OR RATING CONDITION	MINIMUM EFFICIENCY	TEST PROCEDURE <sup>a</sup>
Air cooled (cooling mode)	< 66,000 Btu/h	All	Split system, three phase and applications outside US single phase <sup>b</sup>	14.0 SEER before 1/1/2023 14.3 SEER2 after 1/1/2023	AHRI 210/240—2017 before 1/1/2023 AHRI 210/240—2023 after 1/1/2023
			Single package, three phase and applications outside US single phase <sup>b</sup>	14.0 SEER before 1/1/2023 13.4 SEER2 after 1/1/2023	
Space constrained, air cooled (cooling mode)	≤ 30,000 Btu/h	All	Split system, three phase and applications outside US single phase <sup>b</sup>	12.0 SEER before 1/1/2023 11.7 SEER2 after 1/1/2023	AHRI 210/240—2017 before 1/1/2023 AHRI 210/240—2023 after 1/1/2023
			Single package, three phase and applications outside US single phase <sup>b</sup>	12.0 SEER before 1/1/2023 11.7 SEER2 after 1/1/2023	
Single duct, high velocity, air cooled (cooling mode)	< 65,000	All	Split system, three phase and applications outside US single phase <sup>b</sup>	12.0 SEER before 1/1/2023 12.0 SEER2 after 1/1/2023	AHRI 210/240—2017 before 1/1/2023 AHRI 210/240—2023 after 1/1/2023
Air cooled (cooling mode)	≥ 65,000 Btu/h and < 135,000 Btu/h	Electric resistance (or none)	Split system and single package	11.0 EER 12.2 IEER before 1/1/2023 14.1 IEER after 1/1/2023	AHRI 340/360
		All other		10.8 EER 12.0 IEER before 1/1/2023 13.9 IEER after 1/1/2023	
	≥ 135,000 Btu/h and < 240,000 Btu/h	Electric resistance (or none)		10.6 EER 11.6 IEER before 1/1/2023 13.5 IEER after 1/1/2023	
		All other		10.4 EER 11.4 IEER before 1/1/2023 13.3 IEER after 1/1/2023	
	≥ 240,000 Btu/h	Electric resistance (or none)		9.5 EER 10.6 IEER before 1/1/2023 12.5 IEER after 1/1/2023	
		All other		9.3 EER 10.4 IEER before 1/1/2023 12.3 IEER after 1/1/2023	
Air cooled (heating mode)	< 65,000 Btu/h	All	Split system, three phase and applications outside US single phase <sup>b</sup>	8.2 HSPF before 1/1/2023 7.5 HSPF2 after 1/1/2023	AHRI 210/240—2017 before 1/1/2023 AHRI 210/240—2023 after 1/1/2023
			Single package, three phase and applications outside US single phase <sup>b</sup>	8.0 HSPF before 1/1/2023 6.7 HSPF2 after 1/1/2023	

**IECC2021 Table C403.3.2(2) continued from previous page**

**TABLE C403.3.2(2)—continued  
ELECTRICALLY OPERATED AIR-COOLED UNITARY HEAT PUMPS—MINIMUM EFFICIENCY REQUIREMENTS<sup>a, d</sup>**

EQUIPMENT TYPE	SIZE CATEGORY	HEADING SECTION TYPE	SUBCATEGORY OR RATING CONDITION	MINIMUM EFFICIENCY	TEST PROCEDURE <sup>e</sup>
Space constrained, air cooled (heating mode)	≤ 30,000 Btu/h	All	Split system, three phase and applications outside US single phase <sup>b</sup>	7.4 HSPF before 1/1/2023 6.3 HSPF2 after 1/1/2023	AHRI 210/240—2017 before 1/1/2023 AHRI 210/240—2023 after 1/1/2023
			Single package, three phase and applications outside US single phase <sup>b</sup>	7.4 HSPF before 1/1/2023 6.3 HSPF2 after 1/1/2023	
Small duct, high velocity, air cooled (heating mode)	< 65,000 Btu/h	All	Split system, three phase and applications outside US single phase <sup>b</sup>	7.2 HSPF before 1/1/2023 6.1 HSPF2 after 1/1/2023	AHRI 210/240—2017 before 1/1/2023 AHRI 210/240—2023 after 1/1/2023
Air cooled (heating mode)	≥ 65,000 Btu/h and < 135,000 Btu/h (cooling capacity)	All	47°F db/43°F wb outdoor air	3.30 COP <sub>H</sub> before 1/1/2023 3.40 COP <sub>H</sub> after 1/1/2023	AHRI 340/360
			17°F db/15°F wb outdoor air	2.25 COP <sub>H</sub>	
	≥ 135,000 Btu/h and < 240,000 Btu/h (cooling capacity)		47°F db/43°F wb outdoor air	3.20 COP <sub>H</sub> before 1/1/2023 3.30 SOP <sub>H</sub> after 1/1/2023	
			17°F db/15°F wb outdoor air	2.05 COP <sub>H</sub>	
	≥ 240,000 Btu/h (cooling capacity)		47°F db/43°F wb outdoor air	3.20 COP <sub>H</sub>	
			17°F db/15°F wb outdoor air	2.05 COP <sub>H</sub>	



**Non Fuel Switch example**, a 5-ton single phase split system 60,000 Btuh capacity heat pump, with an efficiency SEER2 of 16, and an efficient HSPF2 of 9.5, at a restaurant in Chicago with a building permit dated after 1/1/2023 saves:

$$\begin{aligned} \Delta kWh &= \text{Annual kWh Savings}_{\text{cool}} + \text{Annual kWh Savings}_{\text{heat}} \\ \text{Annual kWh Savings}_{\text{cool}} &= (\text{Capacity}_{\text{cool}} * \text{EFLH}_{\text{cool}} * (1/\text{SEER}_{\text{base}} - 1/\text{SEER}_{\text{ee}}))/1000 \\ \text{Annual kWh Savings}_{\text{heat}} &= (\text{HeatLoad} * (1/(\text{HSPF}_{\text{base}} * \text{HSPF}_{\text{ClimateAdj}}) - 1/(\text{HSPF}_{\text{ee}} * \text{HSPF}_{\text{ClimateAdj}}))/1000 \\ \Delta kWh &= (60,000 * 1134 * (1/14.3 - 1/16))/1000 + (60,000 * 1354 * (1/(7.5 * 0.7) - 1/(9.5 * 0.7)))/1000 \\ &= 3763 \text{ kWh} \end{aligned}$$

**Fuel Switch Illustrative Examples**

*[for illustrative purposes 50:50 Incentive is used for joint programs]*

New construction using gas furnace and central AC baseline:

For example, a 60,000 Btu, 16 SEER2, 9.5 HSPF2 single phase split system Air Site Heat Pump installed in a Chicago restaurant, in place of a 120,000 Btuh natural gas furnace and 5 ton Central AC unit:

$$\begin{aligned} \text{SiteEnergySavings (MMBTUs)} &= \text{GasHeatReplaced} + \text{FurnaceFanSavings} - \text{HPSiteHeatConsumed} + \text{HPSiteCoolingImpact} \\ \text{GasHeatReplaced} &= (\text{HeatLoad} * 1/\text{AFUE}_{\text{base}}) / 1,000,000 \\ &= (60,000 * 1354 * 1/0.8) / 1000000 \\ &= 101.6 \text{ MMBtu} \\ \text{FurnaceFanSavings} &= (\text{FurnaceFlag} * \text{HeatLoad} * 1/\text{AFUE}_{\text{base}} * F_e) / 1,000,000 \\ &= (1 * 60,000 * 1354 * 1/0.8 * 0.077) / 1,000,000 \\ &= 7.8 \text{ MMBtu} \\ \text{HPSiteHeatConsumed} &= ((\text{HeatLoad} * (1/(\text{HSPF}_{\text{ee}} * \text{HSPF}_{\text{ClimateAdj}}))) / 1000 * 3412) / 1,000,000 \\ &= ((60,000 * 1354 * (1/(9.5 * 0.77))) / 1000 * 3412) / 1,000,000 \\ &= 37.9 \text{ MMBtu} \\ \text{HPSiteCoolingImpact} &= ((\text{FLH}_{\text{cool}} * \text{Capacity}_{\text{cool}} * (1/\text{SEER}_{\text{base}} - 1/\text{SEER}_{\text{ee}}))/1000 * 3412) / 1,000,000 \\ &= ((60,000 * 1134 * (1/14.3 - 1/16)) / 1000 * 3412) / 1,000,000 \\ &= 1.7 \text{ MMBtu} \\ \text{SiteEnergySavings (MMBTUs)} &= 101.6 + 7.8 - 37.9 + 1.7 = 73.2 \text{ MMBtu [Measure is eligible]} \end{aligned}$$

**Fuel Switch Illustrative Example continued**

Savings would be claimed as follows:

Measure supported by:	Electric Utility claims:	Gas Utility claims:
Electric utility only	$73.2 * 1,000,000/3412$ = 21,454 kWh	N/A
Electric and gas utility	$0.5 * 73.2 * 1,000,000/3412$ = 10,727 kWh	$0.5 * 73.2 * 10$ = 366 Therms
Gas utility only	N/A	$73.2 * 10$ = 732 Therms

**SUMMER COINCIDENT PEAK DEMAND SAVINGS**

$$\Delta kW = ((\text{kBtu/hr}_{\text{cool}}) * (1/\text{EER}_{2\text{base}} - 1/\text{EER}_{2\text{ee}})) * \text{CF}$$

Where CF value is chosen between:

$$\begin{aligned} \text{CF}_{\text{SSP}} &= \text{Summer System Peak Coincidence Factor for Commercial cooling (during system peak hour)} \\ &= 91.3\%^{639} \end{aligned}$$

$$\begin{aligned} \text{CF}_{\text{PJM}} &= \text{PJM Summer Peak Coincidence Factor for Commercial cooling (average during peak period)} \\ &= 47.8\%^{640} \end{aligned}$$

**For example**, a 5 ton single phase split system air source heat pump, with an efficient EER2 of 12.5 with a building permit dated after 1/1/2023 saves:

$$\begin{aligned} \Delta kW &= (60 * (1/9.4 - 1/12.5)) * 0.913 \\ &= 1.44 \text{ kW} \end{aligned}$$

**FOSSIL FUEL SAVINGS**

Calculation provided together with Electric Energy Savings above.

**WATER IMPACT DESCRIPTIONS AND CALCULATION**

N/A

**DEEMED O&M COST ADJUSTMENT CALCULATION**

N/A

**COST EFFECTIVENESS SCREENING AND LOAD REDUCTION FORECASTING WHEN FUEL SWITCHING**

This measure can involve fuel switching from gas to electric.

For the purposes of forecasting load reductions due to fuel switch ASHP projects per Section 16-111.5B, changes in site energy use at the customer’s meter (using  $\Delta kWh$  algorithm below), customer switching estimates, NTG, and any other adjustment factors deemed appropriate, should be used.

<sup>639</sup> Based on analysis of Itron eShape data for Missouri, calibrated to Illinois loads, supplied by Ameren. The AC load during the utility’s peak hour is divided by the maximum AC load during the year.

<sup>640</sup> Based on analysis of Itron eShape data for Missouri, calibrated to Illinois loads, supplied by Ameren. The average AC load over the PJM peak period (1-5pm, M-F, June through August) is divided by the maximum AC load during the year.

The inputs to cost effectiveness screening should reflect the actual impacts on the electric and fuel consumption at the customer meter and, for fuel switching measures, should therefore reflect the decrease in one fuel and increase in another, as opposed to the single savings value calculated in the “Electric and Fossil Fuel Energy Savings” section above. Therefore in addition to the calculation of savings claimed, the following values should be used to assess the cost effectiveness of the measure. For Early Replacement measures, the efficiency terms of the existing unit should be used for the remaining useful life of the existing equipment (6 years for ASHP and Central AC, 7 years for furnace, 8 years for boilers or GSHP, 15 years for electric resistance), and the efficiency terms for a new baseline unit should be used for the remaining years of the measure.

$$\begin{aligned} \Delta\text{Therms} &= [\text{Heating Consumption Replaced}] \\ &= [(\text{HeatLoad} * 1/\text{AFUE}_{\text{base}}) / 100,000] \end{aligned}$$

$$\Delta\text{kWh} = [\text{FurnaceFanSavings}] - [\text{HP heating consumption}] + [\text{Cooling savings}]$$

For units with cooling capacities less than 65 kBtu/hr:

$$= [\text{FurnaceFlag} * \text{HeatLoad} * 1/\text{AFUE}_{\text{base}} * F_e * 0.000293] - [(\text{HeatLoad} * (1/(\text{HSPF2}_{\text{ee}} * \text{HSPF2}_{\text{ClimateAdj}}))/1000] + [(\text{Capacity}_{\text{cool}} * \text{EFLH}_{\text{cool}} * (1/\text{SEER2}_{\text{base}} - 1/\text{SEER2}_{\text{ee}}))/1000]$$

For units with cooling capacities greater than 65 kBtu/hr:

$$= [\text{FurnaceFlag} * \text{HeatLoad} * 1/\text{AFUE}_{\text{base}} * F_e * 0.000293] - [\text{HeatLoad}/3412 * (1/\text{COP}_{\text{ee}})] + [(\text{Capacity}_{\text{cool}} * \text{EFLH}_{\text{cool}} * (1/\text{IEER}_{\text{base}} - 1/\text{IEER}_{\text{ee}}))/1000]$$

**MEASURE CODE: CI-HVC-HPSY-V11-240101**

**REVIEW DEADLINE: 1/1/2026**

## 4.4.10 High Efficiency Boiler

### DESCRIPTION

To qualify for this measure the installed equipment must be replacement of an existing boiler at the end of its service life, in a commercial or multifamily space with a high efficiency, gas-fired steam or hot water boiler. High efficiency boilers achieve gas savings through the utilization of a sealed combustion chamber and multiple heat exchangers that remove a significant portion of the waste heat from flue gasses. Because multiple heat exchangers are used to remove waste heat from the escaping flue gasses, some of the flue gasses condense and must be drained.

This measure was developed to be applicable to the following program types: TOS, NC. If applied to other program types, the measure savings should be verified.

### DEFINITION OF EFFICIENT EQUIPMENT

To qualify for this measure the installed equipment must be a boiler used 80% or more for space heating, not process, and boiler AFUE,  $E_T$  (thermal efficiency), or  $E_C$  (combustion efficiency) rating must be rated greater than or equal to 85% for hot water boilers and 83% for steam boilers.

### DEFINITION OF BASELINE EQUIPMENT

Dependent on when the unit is installed and whether the unit is hot water or steam. The baseline efficiency source is the Energy Independence and Security Act of 2007 with technical amendments from Federal Register, volume 85, Number 7, January 10, 2020.<sup>641</sup>

For boilers <300,000 Btu/hr the technical amendments include the recent compliance dates for gas-fired hot water and steam boilers manufactured on or after January 15, 2021.<sup>642</sup>

Note, for natural draft steam boilers, as IECC 2021, Illinois state energy code that is expected to become effective statewide in 2023, exceeds the minimum federal efficiency standards, it was replaced in favor of the more aggressive thermal efficiency values in the table below. For new construction applications where the permitting date is prior to the state's adoption of IECC 2021, it is recommended to use the applicable edition of IECC corresponding to that timeline. As code requirements and adoption can differ from municipality to municipality, the user should verify which version of code is applicable given these constraints.

Each gas-fired commercial packaged boiler listed in Table 2 §431.87 and manufactured on or after January 10, 2023, must meet the applicable energy conservation standard levels detailed in the table below.

---

<sup>641</sup> Energy Conservation Standards for Commercial Boilers, Code of Federal Regulations, 10 CFR 431.87

<sup>642</sup> Code of Federal Regulations, effective January 15, 2021 (10 CFR 432(e)(3)).

**Boiler baseline efficiency standards**

Boiler Type	Efficiency <sup>643</sup>
Hot Water Boiler < 300,000 Btu/h	84% AFUE
Hot Water Boiler ≥ 300,000 Btu/h and ≤ 2,500,000 Btu/h	84% E <sub>T</sub>
Hot Water Boiler > 2,500,000 Btu/h and ≤ 10,000,000 Btu/h	85% E <sub>C</sub>
Hot Water Boiler > 10,000,000 Btu/h	82% E <sub>C</sub>
Steam Boiler < 300,000 Btu/h	82% AFUE
Steam Boiler ≥ 300,000 Btu/h and ≤ 2,500,000 Btu/h	81% E <sub>T</sub>
Steam Boiler ≥ 2,500,000 Btu/h and ≤ 10,000,000 Btu/h	82% E <sub>T</sub>
Steam Boiler > 10,000,000 Btu/h	79% E <sub>T</sub>

**DEEMED LIFETIME OF EFFICIENT EQUIPMENT**

The expected measure life is assumed to be 25 years.<sup>644</sup>

**DEEMED MEASURE COST**

The measure cost for this technology is tiered based on the boiler type and combustion efficiencies. As installation costs for the base case and the measure case units are assumed to be the same, labor costs are not specified for this measure.

**Incremental and Gross Measure costs for Space Heating Boilers**

Boiler Type	Incremental Measure Cost (\$/KBtu) <sup>645</sup>	Full Installed Measure Cost (\$/KBtu) <sup>646</sup>
Hot Water Boiler ≥85% E <sub>C</sub> and <90% E <sub>C</sub>	\$2.17	\$12.94
Hot Water Boiler ≥90% E <sub>C</sub>	\$12.17	\$22.95
Steam Boiler ≥83% E <sub>C</sub> and <85% E <sub>C</sub>	\$4.35	\$19.24
Modular Steam Boiler Arrays (>85% E <sub>C</sub> ) <sup>647</sup>	Custom	

**LOADSHAPE**

N/A

**COINCIDENCE FACTOR**

N/A

---

**Algorithm**

---

**CALCULATION OF ENERGY SAVINGS**

**ELECTRIC ENERGY SAVINGS**

N/A

<sup>643</sup> Code of Federal Regulations, 10 CFR 431.82

<sup>644</sup> Consistent with DOE assumption determined through a literature review in Appendix 8-F of the Department of Energy Commercial Technical Support Document.

<sup>645</sup> Ibid.

<sup>646</sup> Ibid.

<sup>647</sup> Miura Modular Boilers, <https://s29958.pcdn.co/wp-content/uploads/2019/03/LXBrochure2016.pdf>

**SUMMER COINCIDENT PEAK DEMAND SAVINGS**

N/A

**FOSSIL FUEL SAVINGS**

$$\Delta\text{Therms} = \text{EFLH} * \text{Capacity} * ((\text{Efficiency}_{\text{EE}} - \text{Efficiency}_{\text{Base}}) / \text{Efficiency}_{\text{Base}}) / 100,000$$

Where:

EFLH = Equivalent Full Load Hours for heating in Existing Buildings or New Construction are provided in section 4.4 HVAC End Use

Capacity = Nominal Heating Input Capacity Boiler Size (Btu/hr) for efficient unit not existing unit  
 = custom Boiler input capacity in Btu/hr

Efficiency<sub>Base</sub> = Baseline Boiler Efficiency Rating, dependant on year and boiler type

Hot water boiler baseline:

Boiler Capacity and Distribution Type	Efficiency
Hot Water <300,000 Btu/hr <sup>648</sup>	84% AFUE
Hot Water ≥300,000 & ≤2,500,000 Btu/hr <sup>649</sup>	84% E <sub>T</sub>
Hot Water Boiler > 2,500,000 Btu/h and ≤10,000,000 Btu/h <sup>650</sup>	85% E <sub>C</sub>
Hot Water Boiler >10,000,000 Btu/h <sup>651</sup>	82% E <sub>C</sub>

Steam boiler baseline:

Boiler Capacity and Distribution Type	Efficiency
Steam <300,000 Btu/hr	82% AFUE
Steam Boiler ≥ 300,000 Btu/h and ≤ 2,500,000 Btu/h <sup>652</sup>	81% E <sub>T</sub>
Steam - natural draft ≥300,000 & ≤2,500,000 Btu/hr	79% TE <sup>653</sup>
Steam Boiler ≥ 2,500,000 Btu/h and ≤10,000,000 Btu/h	82% E <sub>T</sub>
Steam - natural draft >2,500,000 Btu/hr	79% E <sub>T</sub> <sup>654</sup>
Steam Boiler > 10,000,000 Btu/h	79% E <sub>T</sub>

Efficiency<sub>EE</sub> = Efficient Boiler Efficiency Rating  
 =actual value, specified to one significant digit (i.e., 95.7%)

**For example**, a 150,000 btu/hr water boiler meeting AFUE 90% is installed in Rockford at a high rise office building , in the year 2022

$$\begin{aligned} \Delta\text{Therms} &= 2,089 * 150,000 * (0.90-0.840)/0.840 / 100,000 \text{ Btu/Therm} \\ &= 224 \text{ Therms} \end{aligned}$$

<sup>648</sup> Code of Federal Regulations, effective January 10, 2023 (10 CFR 432(e)(3)).

<sup>649</sup> Thermal Efficiency. Code of Federal Regulations, effective January 10, 2023 (10 CFR 431.87).

<sup>650</sup> Combustion Efficiency. Code of Federal Regulations, effective January 10, 2023 (10 CFR 431.87).

<sup>651</sup> Code of Federal Regulations, effective January 10, 2023 (10 CFR 432(e)(3)).

<sup>652</sup> Code of Federal Regulations, effective January 10, 2023 (10 CFR 431.87). Includes efficiency requirements for all steam boilers ≥ 300,000 Btu/hr.

<sup>653</sup> IECC 2021

<sup>654</sup> IECC 2021

**WATER IMPACT DESCRIPTIONS AND CALCULATION**

N/A

**DEEMED O&M COST ADJUSTMENT CALCULATION**

N/A

**MEASURE CODE: CI-HVC-BOIL-V11-240101**

**REVIEW DEADLINE: 1/1/2027**

#### 4.4.11 High Efficiency Furnace

##### DESCRIPTION

This measure covers the installation of a residential sized (<225,000 Btu/hr) or commercial sized (>=225,000 Btu/hr) high efficiency gas furnace in lieu of a standard efficiency gas furnace in a commercial or industrial space. Note commercial sized condensing gas units (>= 225,000 Btu/hr) heating 100% outside air should use 4.4.37 Unitary HVAC Condensing Furnace if appropriate. High efficiency gas furnaces achieve savings through the utilization of a sealed, super insulated combustion chamber, more efficient burners, and multiple heat exchangers that remove a significant portion of the waste heat from the flue gasses. Because multiple heat exchangers are used to remove waste heat from the escaping flue gasses, most of the flue gasses condense and must be drained.

This measure also describes savings from a brushless permanent magnet (BPM) motor (known and referred in this measure as an electronically commutated motor (ECM)) compared to a lower efficiency motor within a residential sized unit. Time of Sale and New Construction scenarios can no longer claim these electrical savings, as federal standards make ECM blower fan motors a requirement for residential-sized furnaces.<sup>655</sup> Savings however are available from replacing an operational inefficient furnace with a new furnace with an ECM prior to the end of its life.

This measure was developed to be applicable to the following program types: TOS, NC and EREP. If applied to other program types, the measure savings should be verified.

Time of sale:

- a. The installation of a new high efficiency, gas-fired condensing furnace in a commercial location. This could relate to the replacement of an existing unit at the end of its useful life, or the installation of a new system.

Early replacement:

Early Replacement determination will be based on meeting the following conditions:

- The existing unit is operational when replaced, or
- The existing unit requires minor repairs (<\$528).<sup>656</sup>
- All other conditions will be considered Time of Sale.

The Baseline AFUE of the existing unit replaced:

- If the AFUE of the existing unit is known, the Baseline AFUE is the actual AFUE value of the unit replaced.
- If the AFUE of the existing unit is unknown, use assumptions in variable list below (AFUE(exist)).
- If the operational status or repair cost of the existing unit is unknown, use time of sale assumptions.

##### DEFINITION OF EFFICIENT EQUIPMENT

To qualify for this measure the installed equipment must be a furnace with input energy less than 225,000 Btu/hr rated natural gas fired furnace with an Annual Fuel Utilization Efficiency (AFUE) rating and fan electrical efficiency exceeding the program requirements:

---

<sup>655</sup> As part of the code of federal regulations, energy conservation standards for covered residential furnace fans become effective on July 3, 2019 (10 CFR 430.32(y)). The expectation is the baseline will essentially become an ECM motor.

<sup>656</sup> The Technical Advisory Committee agreed that if the cost of repair is less than 20% of the new baseline replacement cost it can be considered early replacement. Note the non-inflated cost is used as this would be a cost consideration in the program year.



**DEFINITION OF BASELINE EQUIPMENT**

Time of Sale: The current Federal Standard for gas furnaces <225,000 Btu/hr is an AFUE rating of 80%.  
 For furnaces ≥225,000 Btu/hr, the baseline AFUE rating is 81%.

Early replacement: The baseline for this measure is the efficiency of the existing equipment for the assumed remaining useful life of the unit and a new baseline 80% AFUE for Residential sized or 81% AFUE for Commercial sized unit for the remainder of the measure life.

**DEFINITION OF MEASURE LIFE**

The expected measure life is assumed to be 16.5 years.<sup>657</sup>  
 Remaining life of existing equipment is assumed to be 5.5 years.<sup>658</sup>

**DEEMED MEASURE COST**

For residential sized units (<225,000 Btu/hr):  
 Time of Sale: The incremental capital cost for this measure depends on efficiency as listed below:<sup>659</sup>

AFUE	Installation Cost	Incremental Install Cost
80%	\$2011	n/a
90%	\$2641	\$630
91%	\$2727	\$716
92%	\$2813	\$802
93%	\$3025	\$1,014
94%	\$3237	\$1,226
95%	\$3449	\$1,438
96%	\$3661	\$1,650
97%	\$3873	\$1,862

Early Replacement: The full installation cost is provided in the table above. The assumed deferred cost (after 5.5 years) of replacing existing equipment with a new 80% baseline unit is assumed to be \$2,231.<sup>660</sup> This cost should be discounted to present value using the nominal discount rate.

For commercial sized units (≥225,000 Btu/hr) – actual costs should be used.

**LOADSHAPE**

N/A

**COINCIDENCE FACTOR**

N/A

---

<sup>657</sup> Average of 15-18 year lifetime estimate made by the Consortium for Energy Efficiency in 2010.  
<sup>658</sup> Assumed to be one third of effective useful life.  
<sup>659</sup> Based on data from Appendix E of the US DOE Appliance Standards Technical Support Documents including equipment cost and installation labor. Where efficiency ratings are not provided, the values are interpolated from those that are.  
<sup>660</sup> \$2011 inflated using 1.91% rate.

**Algorithm**

**CALCULATION OF SAVINGS**

**ELECTRIC ENERGY SAVINGS**

Residential sized (<225,000 Btu/hr), Early Replacement Only:

For remaining useful life of the existing furnace (assumed 5.5 years):

$$\Delta kWh = \text{Heating Savings} + \text{Cooling Savings} + \text{Shoulder Season Savings}$$

Where:

Heating Savings = Brushless DC motor or Electronically commutated motor (ECM)  
= 418 kWh<sup>661</sup>

Cooling Savings = Brushless DC motor or electronically commutated motor (ECM)  
savings during cooling season

If air conditioning = 263 kWh

If no air conditioning = 175 kWh

If unknown (weighted average)= 241 kWh<sup>662</sup>

Shoulder Season Savings = Brushless DC motor or electronically commutated motor (ECM)  
savings during shoulder seasons

= 51 kWh

**For example**, a blower motor in a low rise office building where air conditioning presence is unknown:

$$\begin{aligned} \Delta kWh &= \text{Heating Savings} + \text{Cooling Savings} + \text{Shoulder Season Savings} \\ &= 418 + 241 + 51 \\ &= 710 \text{ kWh} \end{aligned}$$

For remaining measure life of the existing furnace (next 11 years): 0 kWh

All other applications assume 0 kWh.

**SUMMER COINCIDENT PEAK DEMAND SAVINGS**

Residential sized (<225,000 Btu/hr) Early Replacement Only:

For remaining useful life of the existing furnace (assumed 5.5 years):

For units that have evaporator coils and condensing units and are cooling in the summer in addition to heating in the winter the summer coincident peak demand savings should be calculated. If the unit is not equipment with coils or condensing units, the summer peak demand savings will not apply.

<sup>661</sup> To estimate heating, cooling and shoulder season savings for Illinois, VEIC adapted results from a 2009 Focus on Energy study of BPM blower motor savings in Wisconsin. This study included effects of behavior change based on the efficiency of new motor greatly increasing the amount of people that run the fan continuously. The savings from the Wisconsin study were adjusted to account for different run hour assumptions (average values used) for Illinois. See: FOE to IL Blower Savings.xlsx.

<sup>662</sup> The weighted average value is based on assumption that 75% of buildings installing BPM furnace blower motors have Central AC.

$$\Delta kW = (\text{CoolingSavings}/\text{HOURSyear}) * CF$$

Where:

HOURSyear = Actual hours per year if known, otherwise use hours from Table below for building type:<sup>663</sup>

Building Type	HOURSyear	Model source
Assembly	2150	eQuest
Assisted Living	4373	eQuest
Auto Dealership	1605	OpenStudio
College	4065	OpenStudio
Convenience Store	2084	eQuest
Drug Store	1708	OpenStudio
Elementary School	2649	OpenStudio
Emergency Services	3277	OpenStudio
Garage	2102	eQuest
Grocery	5470	OpenStudio
Healthcare Clinic	6364	OpenStudio
High School	3141	eQuest
Hospital - VAV econ	8707	OpenStudio
Hospital - CAV econ	2336	OpenStudio
Hospital - CAV no econ	4948	OpenStudio
Hospital - FCU	8760	OpenStudio
Manufacturing Facility	2805	eQuest
MF - High Rise	6823	OpenStudio
MF - Mid Rise	4996	OpenStudio
Hotel/Motel – Guest	4155	OpenStudio
Hotel/Motel - Common	6227	OpenStudio
Movie Theater	2120	eQuest
Office - High Rise - VAV econ	3414	OpenStudio
Office - High Rise - CAV econ	4849	eQuest
Office - High Rise - CAV no econ	6049	OpenStudio
Office - High Rise - FCU	5341	OpenStudio
Office - Low Rise	3835	OpenStudio
Office - Mid Rise	3040	OpenStudio
Religious Building	2830	eQuest
Restaurant	2305	OpenStudio
Retail - Department Store	2528	eQuest
Retail - Strip Mall	2266	eQuest
Warehouse	770	eQuest
Unknown	2987	n/a

CF =Summer Peak Coincidence Factor for measure is provided below for different building types:<sup>664</sup>

HVAC Pumps	CF
Assembly	48.3%
Assisted Living	52.9%

<sup>663</sup> Hours per year are estimated using the eQuest or OpenStudio models as the total number of hours the cooling system is operating for each building type.

<sup>664</sup> Coincidence Factors are estimated using the eQuest models.

HVAC Pumps	CF
College	14.2%
Convenience Store	57.1%
Elementary School	33.3%
Emergency Services	19.6%
Garage	61.9%
Grocery	47.5%
Healthcare Clinic	61.9%
High School	28.8%
Hospital - VAV econ	57.6%
Hospital - CAV econ	61.5%
Hospital - CAV no econ	64.8%
Hospital - FCU	60.9%
Manufacturing Facility	43.3%
MF - High Rise - Common	43.7%
MF - Mid Rise	24.3%
Hotel/Motel - Guest	62.9%
Hotel/Motel - Common	64.6%
Movie Theater	41.9%
Office - High Rise - VAV econ	43.2%
Office - High Rise - CAV econ	48.3%
Office - High Rise - CAV no econ	50.3%
Office - High Rise - FCU	46.2%
Office - Low Rise	47.4%
Office - Mid Rise	42.8%
Religious Building	43.3%
Restaurant	48.8%
Retail - Department Store	50.5%
Retail - Strip Mall	52.8%
Warehouse	22.5%
Unknown	42.4%

**For example**, a blower motor in a low rise office building where air conditioning presence is unknown:

$$\begin{aligned} \Delta kW &= (241 / 2481) * 0.474 \\ &= 0.05 \text{ kW} \end{aligned}$$

For remaining measure life of the existing furnace (next 11 years): 0 kW

All other applications assume 0 kWh.

**FOSSIL FUEL SAVINGS**

Time of Sale:

$$\Delta \text{Therms} = (\text{EFLH} * \text{Capacity} * (\text{AFUE}(\text{eff}) / \text{AFUE}(\text{base}) - 1)) / 100,000$$

Early replacement<sup>665</sup>:

ΔTherms for remaining life of existing unit (1st 5.5 years):

$$\Delta\text{Therms} = (\text{EFLH} * \text{Capacity} * (\text{AFUE}(\text{eff}) / \text{AFUE}(\text{exist}) - 1)) / 100,000$$

ΔTherms for remaining measure life (next 11 years):

$$\Delta\text{Therms} = (\text{EFLH} * \text{Capacity} * (\text{AFUE}(\text{eff}) / \text{AFUE}(\text{base}) - 1)) / 100,000$$

Where:

EFLH = Equivalent Full Load Hours for heating in Existing Buildings or New Construction are provided in section 4.4 HVAC End Use

Capacity = Nominal Heating Input Capacity Furnace Size (Btu/hr) for efficient unit not existing unit  
= custom Furnace input capacity in Btu/hr

AFUE(exist) = Existing Furnace Annual Fuel Utilization Efficiency Rating  
= Use actual AFUE rating where it is possible to measure or reasonably estimate.  
If unknown, assume 64.4 AFUE%.<sup>666</sup>

AFUE(base) = Baseline Furnace Annual Fuel Utilization Efficiency Rating  
= For residential sized units (<225,000 Btu/hr): 80%<sup>667</sup>  
= For commercial sized units (>=225,000 Btu/hr):

Program	AFUE(base)
Time of Sale	81% <sup>668</sup>
Early Replacement	81% <sup>669</sup>

AFUE(eff) = Efficient Furnace Annual Fuel Utilization Efficiency Rating.  
= Actual. If Unknown, assume 95%.<sup>670</sup>

**For example,**

$$\begin{aligned} \Delta\text{Therms} &= (1428 * 150,000 * (0.92 / 0.80 - 1)) / 100,000 \\ &= 321 \text{ Therms} \end{aligned}$$

#### WATER IMPACT DESCRIPTIONS AND CALCULATION

N/A

#### DEEMED O&M COST ADJUSTMENT CALCULATION

N/A

<sup>665</sup> The two equations are provided to show how savings are determined during the initial phase of the measure (existing to efficient) and the remaining phase (new baseline to efficient). In practice, the screening tools used may either require a First Year savings (using the first equation) and then a “number of years to adjustment” and “savings adjustment” input which would be the (new base to efficient savings)/(existing to efficient savings).

<sup>666</sup> Average nameplate efficiencies of all Early Replacement qualifying equipment in Ameren PY3-PY4.

<sup>667</sup> Residential sized units as per Code of Federal Regulations, effective November, 2015 (10 CFR 432(e)).

<sup>668</sup> Commercial sized units as per Code of Federal Regulations, effective January 2023 (10 CFR 431(d)).

<sup>669</sup> Commercial sized units as per Code of Federal Regulations, effective January 1, 2023 (10 CFR 431(d)).

<sup>670</sup> Minimum ENERGY STAR efficiency after 2.1.2012.

**MEASURE CODE: CI-HVC-FRNC-V13-240101**

**REVIEW DEADLINE: 1/1/2027**

## 4.4.12 Infrared Heaters

### DESCRIPTION

A natural gas-fired radiant infrared heater uses the combustion of natural gas to heat a metal tube or ceramic panel to a very high temperature (typically between 1200 and 5000 degrees Fahrenheit). The high surface temperature causes radiative heat transfer between the heater surface and its surroundings. The surroundings will re-radiate the heat to occupants and release heat through convection to the air, providing a comfortable environment without directly heating air.

Infrared heaters are ideal for space heating applications where there are elevated ceilings with high thermal stratification, spaces with high ventilation or air infiltration rates, or a need for spot heating within an unconditioned or industrial space. Aircraft hangers, warehouses, greenhouses, manufacturing production areas, pools, and loading docks are space types that can be efficiently served by a radiant infrared heater.

This measure was developed to be applicable to the following program types: TOS, NC. If applied to other program types, the measure savings should be verified.

### DEFINITION OF EFFICIENT EQUIPMENT

To qualify for this measure the installed equipment must be a natural gas heater with an electric ignition that uses non-conditioned air for combustion. Gross Radiant Coefficient (GRC) is provided by the manufacturer and defined as the ratio of radiant heat output delivered in Btu to the natural gas input energy.<sup>671</sup>

### DEFINITION OF BASELINE EQUIPMENT

The baseline equipment is a standard natural gas fired warm air heater.

### DEEMED LIFETIME OF EFFICIENT EQUIPMENT

The expected measure life is assumed to be 15 years.<sup>672</sup>

### DEEMED MEASURE COST

The incremental capital cost for this measure is \$2.70 per kBtu/hr input capacity.<sup>673</sup>

### LOADSHAPE

N/A

### COINCIDENCE FACTOR

N/A

---

### Algorithm

---

### CALCULATION OF SAVINGS

#### ELECTRIC ENERGY SAVINGS

N/A

---

<sup>671</sup> "AHRI Standard 1330 - 2014 Standard for Performance Rating for Radiant Output of Gas Fired Infrared Heaters". 2014. Air Conditioning, Heating, and Refrigeration Institute. Arlington, VA.

<sup>672</sup> 2020 Michigan Energy Measures Database (MEMD). Please see file "mi\_master\_measure\_database\_2020-011020\_681298\_7.xlsx"

<sup>673</sup> 2020 Michigan Energy Measures Database (MEMD). Please see file "mi\_master\_measure\_database\_2020-011020\_681298\_7.xlsx"

**SUMMER COINCIDENT PEAK DEMAND SAVINGS**

N/A

**FOSSIL FUEL SAVINGS**

Natural gas savings for this measure are based on the standard practice of HVAC designers to size a gas-fired radiant infrared heater at a lower input capacity than an equivalent warm air unit heater for an identical application.

$$\Delta\text{Therms} = \text{Therms}(\text{base}) - \text{Therms}(\text{IR})$$

$$\text{Therms}(\text{base}) = \text{Capacity} / \text{RSF} * \text{EFLH} / 100,000$$

$$\text{Therms}(\text{IR}) = \text{Capacity} * \text{EFLH} / 100,000$$

Where:

Capacity = Input capacity of radiant infrared heater in btu/hr  
 = Actual

RSF = Radiation Sizing Factor, dependent on Gross Radiant Coefficient<sup>674</sup> as listed below:<sup>675,676</sup>  
 If Gross Radiant Coefficient is unavailable, assume RSF = 0.85.

Gross Radiant Coefficient (GRC)	RSF (Radiation Sizing Factor)
GRC < 0.67	0.85
0.67 ≤ GRC	0.70

EFLH = Equivalent Full Load Hours for heating in Existing Buildings or New Construction are provided in section 4.4 HVAC End Use

100,000 = Btu to therm conversion factor

**For example:** a radiant heater with a natural gas input capacity of 125,000 Btu/hr and a Gross Radiant Coefficient of 0.45 installed in a warehouse in Chicago will save:

$$\Delta\text{Therms} = \text{Therms}(\text{base}) - \text{Therms}(\text{IR})$$

$$\text{Therms}(\text{base}) = 125,000 / 0.85 * 1286 / 100,000 = 1891.176 \text{ Therms}$$

$$\text{Therms}(\text{IR}) = 125,000 * 1286 / 100,000 = 1607.500 \text{ Therms}$$

$$\Delta\text{Therms} = 1891.176 - 1607.500 = 283.676 \text{ Therms}$$

**WATER IMPACT DESCRIPTIONS AND CALCULATION**

N/A

<sup>674</sup> GRC should be provided by the manufacturer.

<sup>675</sup> Radiant Heat Output (RSF) value determined by testing as per 2016 ASHRAE® HANDBOOK: Heating, Ventilating, and Air-Conditioning SYSTEMS AND EQUIPMENT, Inch-Pound Edition, Chapter 16, pg. 16.1, "Energy Conservation," 2016, American Society of Heating, Refrigerating, and Air-Conditioning Engineers, Inc. Atlanta, GA.

<sup>676</sup> "Put Your Infra-Red Knowledge to the Test". Contracting Canada, July - August 2002.



**DEEMED O&M COST ADJUSTMENT CALCULATION**

N/A

**MEASURE CODE: CI-HVC-IRHT-V03-230101**

**REVIEW DEADLINE: 1/1/2025**

#### 4.4.13 Package Terminal Air Conditioner (PTAC) and Package Terminal Heat Pump (PTHP)

##### DESCRIPTION

A PTAC is a packaged terminal air conditioner that cools and sometimes provides heat through an electric resistance heater (heat strip). A PTHP is a packaged terminal heat pump. A PTHP uses its compressor year round to heat or cool. In warm weather, it efficiently captures heat from inside your building and pumps it outside for cooling. In cool weather, it captures heat from outdoor air and pumps it into your home, adding heat from electric heat strips as necessary to provide heat.

This measure characterizes:

Time of Sale: the purchase and installation of a new efficient PTAC or PTHP.

Early Replacement: the early removal of existing HVAC system from service, prior to its natural end of life, and replacement with a new efficient PTAC or PTHP unit. Savings are calculated between existing unit and efficient unit consumption during the remaining life of the existing unit, and between new baseline unit and efficient unit consumption for the remainder of the measure life.

This measure was developed to be applicable to the following program types: TOS NC, EREP. If applied to other program types, the measure savings should be verified.

##### DEFINITION OF EFFICIENT EQUIPMENT

In order for this characterization to apply, the efficient equipment is assumed to be PTACs or PTHPs that exceed baseline efficiencies.

##### DEFINITION OF BASELINE EQUIPMENT

Time of Sale: the baseline condition is equipment that meets the Code energy efficiency requirements (IECC or Code of Federal Regulations whichever is higher) in effect on the date of equipment purchase (if date is unknown, assume current Code minimum).

Early Replacement: the baseline is the existing HVAC equipment for the assumed remaining useful life of the unit and the new baseline as defined above for the remainder of the measure life.

##### DEEMED LIFETIME OF EFFICIENT EQUIPMENT

The expected measure life is assumed to be 8 years.<sup>677</sup>

Remaining life of existing equipment is assumed to be 3 years.<sup>678</sup>

##### DEEMED MEASURE COST

Time of Sale: The incremental capital cost for this equipment is estimated to be \$84/ton.<sup>679</sup>

Early Replacement: The measure cost is the full cost of removing the existing unit and installing a new one. The actual program cost should be used. If unknown assume \$1,047 per ton.<sup>680</sup>

The assumed deferred cost (after 5 years) of replacing existing equipment with new baseline unit is assumed to be \$1,039 per ton.<sup>681</sup> This cost should be discounted to present value using the nominal discount rate.

---

<sup>677</sup> Based on 2015 DOE Technical Support Document, as recommended in Navigant 'ComEd Effective Useful Life Research Report', May 2018.

<sup>678</sup> Standard assumption of one third of effective useful life.

<sup>679</sup> DEER 2008. This assumes that baseline shift from IECC 2012 to IECC 2015 carries the same incremental costs. Values should be verified during evaluation.

<sup>680</sup> Based on DCEO – IL PHA Efficient Living Program data.

<sup>681</sup> Based on subtracting TOS incremental cost from the DCEO data and incorporating inflation rate of 1.91%.

## LOADSHAPE

Loadshape C03 - Commercial Cooling

## COINCIDENCE FACTOR

The summer peak coincidence factor for cooling is provided in two different ways below. The first is used to estimate peak savings during the utility peak hour and is most indicative of actual peak benefits, and the second represents the *average* savings over the defined summer peak period and is presented so that savings can be bid into PJM’s capacity market. Both values provided are based on analysis of Itron eShape data for Missouri, calibrated to Illinois loads, supplied by Ameren.

$$\begin{aligned} CF_{SSP} &= \text{Summer System Peak Coincidence Factor for Commercial cooling (during system peak hour)} \\ &= 91.3\%^{682} \end{aligned}$$

$$\begin{aligned} CF_{PJM} &= \text{PJM Summer Peak Coincidence Factor for Commercial cooling (average during peak period)} \\ &= 47.8\%^{683} \end{aligned}$$

---

### Algorithm

---

## CALCULATION OF SAVINGS

### ELECTRIC ENERGY AND FOSSIL FUEL SAVINGS

Non Fuel Switch Measures

Electric savings for PTACs and PTHPs should be calculated using the following algorithms

Time of Sale:

$$\text{PTAC } \Delta \text{kWh}^{684} = \text{Annual kWh Savings}_{\text{cool}}$$

$$\text{PTHP } \Delta \text{kWh} = \text{Annual kWh Savings}_{\text{cool}} + \text{Annual kWh Savings}_{\text{heat}}$$

$$\text{Annual kWh Savings}_{\text{cool}} = \text{CoolingLoad} * (1/\text{EER}_{\text{base}} - 1/\text{EER}_{\text{ee}})$$

$$\text{Annual kWh Savings}_{\text{heat}} = (\text{HeatLoad} * (1/\text{COP}_{\text{base}} - 1/\text{COP}_{\text{ee}})) / 3.412$$

Early Replacement:

$$\Delta \text{kWh for remaining life of existing unit (1}^{\text{st}} \text{ 5years)} = \text{Annual kWh Savings}_{\text{cool}} + \text{Annual kWh Savings}_{\text{heat}}$$

$$\text{Annual kWh Savings}_{\text{cool}} = \text{CoolingLoad} * (1/\text{EER}_{\text{exist}} - 1/\text{EER}_{\text{ee}})$$

$$\text{Annual kWh Savings}_{\text{heat}} = (\text{HeatLoad} * (1/\text{COP}_{\text{exist}} - 1/\text{COP}_{\text{ee}})) / 3.412$$

$$\Delta \text{kWh for remaining measure life (next 10 years)} = \text{Annual kWh Savings}_{\text{cool}} + \text{Annual kWh Savings}_{\text{heat}}$$

$$\text{Annual kWh Savings}_{\text{cool}} = \text{CoolingLoad} * (1/\text{EER}_{\text{base}} - 1/\text{EER}_{\text{ee}})$$

$$\text{Annual kWh Savings}_{\text{heat}} = (\text{HeatLoad} * (1/\text{COP}_{\text{base}} - 1/\text{COP}_{\text{ee}})) / 3.412$$

---

<sup>682</sup> Based on analysis of Itron eShape data for Missouri, calibrated to Illinois loads, supplied by Ameren. The AC load during the utility’s peak hour is divided by the maximum AC load during the year.

<sup>683</sup> Based on analysis of Itron eShape data for Missouri, calibrated to Illinois loads, supplied by Ameren. The average AC load over the PJM peak period (1-5pm, M-F, June through August) is divided by the maximum AC load during the year.

<sup>684</sup> There are no heating efficiency improvements for PTACs since although some do provide heating, it is always through electric resistance and therefore the COP<sub>base</sub> and COP<sub>ee</sub> would be 1.0.

Fuel switch measures:

Fuel switch measures must produce positive total energy savings (i.e., reduction in Btus at the premises) in order to qualify. This is determined as follows:

$$\begin{aligned} \text{SiteEnergySavings (MMBTUs)} &= \text{FuelSwitchSavings} + \text{NonFuelSwitchSavings} \\ \text{FuelSwitchSavings} &= (\text{GasHeatReplaced} - \text{ElectricHeatConsumed}) \\ \text{NonFuelSwitchSavings} &= \text{CoolingImpact} \end{aligned}$$

Where:

$$\begin{aligned} \text{GasHeatReplaced} &= (\text{HeatLoad} * 1/\text{FossilEff}_{\text{base}}) / 1,000 \\ \text{ElectricHeatConsumed} &= (\text{HeatLoad} * 1/\text{COP}_{\text{ee}}) / 1000 \\ \text{CoolingImpact} &= \text{CoolLoad} * ((1/\text{EER}_{\text{base}}) - (1/\text{EER}_{\text{ee}})) * 3,412/1,000,000 \end{aligned}$$

If SiteEnergySavings calculated above is positive, the measure is eligible.

The appropriate savings claim is dependent on which utilities are supporting the measure as provided in a table below:

Measure supported by:	Electric Utility claims (kWh):	Gas Utility claims (therms):
Electric utility only	SiteEnergySavings * 1,000,000/3,412	N/A
Electric and gas utility (Note utilities may make alternative agreements to how savings are allocated as long as total MMBtu savings remains the same).	%IncentiveElectric * SiteEnergySavings * 1,000,000/3,412	%IncentiveGas * SiteEnergySavings * 10
Gas utility only	N/A	SiteEnergySavings * 10

Note for Early Replacement measures, the efficiency terms of the existing unit should be used for the remaining useful life of the existing equipment and the efficiency terms for a new baseline unit should be used for the remaining years of the measure. See assumptions below.

Where:

$$\begin{aligned} \text{CoolingLoad} &= \text{Annual cooling load for the space being served} \\ &= \text{kBtu/hr}_{\text{cool}} * \text{EFLH}_{\text{cool}} \\ \text{kBtu/hr}_{\text{cool}} &= \text{capacity of the cooling equipment in kBtu per hour (1 ton of cooling capacity equals 12 kBtu/hr).} \\ &= \text{Actual installed} \\ \text{EFLH}_{\text{cool}} &= \text{Equivalent Full Load Hours for cooling in Existing Buildings or New Construction are provided in section 4.4 HVAC End Use:} \\ \text{HeatLoad} &= \text{Annual heat load for the space being served} \\ &= \text{kBtu/hr}_{\text{heat}} * \text{EFLH}_{\text{heat}} \\ \text{kBtu/hr}_{\text{heat}} &= \text{capacity of the heating equipment in kBtu per hour.} \\ &= \text{Actual installed} \end{aligned}$$

$EFLH_{heat}$  = Equivalent Full Load Hours for heating in Existing Buildings or New Construction are provided in section 4.4 HVAC End Use

$EER_{exist}$  = Energy Efficiency Ratio of the existing equipment  
 = Actual. If unknown assume 10.2 EER for PTAC and 10.4 EER for PTHP.<sup>685</sup>

$EER_{base}$  = Energy Efficiency Ratio of the baseline equipment; see the table below for values.  
 = Based on applicable Code on date of equipment purchase (if unknown assume current Code)

**Copy of Table C403.2.3(3): Minimum Efficiency Requirements: Electrically operated packaged terminal air conditioners, packaged terminal heat pumps**

Equipment Type	IECC 2015/2018 Minimum Efficiency (baseline effective 1/1/2016)	Federal Regulations Minimum Efficiency (baseline effective 1/1/2019)
PTAC (Cooling mode) Standard Sized	14.0 – (0.300 x Cap/1000) EER	14.0 – (0.300 x Cap/1000) EER Compliance date: 1/1/2017
PTAC (Cooling mode) Non-Standard Size*	10.9 – (0.213 x Cap/1000) EER	10.9 – (0.213 x Cap/1000) EER Compliance date: 10/7/2010
PTHP (Cooling mode) Standard Sized	14.0 – (0.300 x Cap/1000) EER	14.0 – (0.300 x Cap/1000) EER Complainance date: 10/8/2012
PTHP (Cooling mode) Non-Standard Size*	10.8 – (0.213 x Cap/1000) EER	10.8 – (0.213 x Cap/1000) EER Compliance date: 10/7/2010
PTHP (Heating mode) Standard Sized	3.2 – (0.026 x Cap/1000) COP	3.7 – (0.052 x Cap/1000) COP Compliance date: 10/8/2012
PTHP (Heating mode) Non-Standard Size*	2.9 – (0.026 x Cap/1000) COP	2.9 – (0.026 x Cap/1000) COP Compliance date: 10/7/2010

Table notes: “Cap” = The rated cooling capacity of the project in Btu/hr. If the units capacity is less than 7000 Btu/hr, use 7,000 Btu/hr in the calculation. If the unit’s capacity is greater than 15,000 Btu/hr, use 15,000 Btu/hr in the calculations.

\* Non-Standard Size apply only to units with existing sleeves less than 16 inches (406mm) in height and less than 42 inches (1067 mm) in width. Replacement unit shall be factory labeled as follows “MANUFACTURED FOR REPLACEMENT APPLICATIONS ONLY; NOT TO BE INSTALLED IN NEW CONSTRUCTION PROJECTS”.

$EER_{ee}$  = Energy Efficiency Ratio of the energy efficient equipment. For air-cooled units < 65 kBtu/hr, if the actual  $EER_{ee}$  is unknown, assume the following conversion from SEER to EER for calculation of peak savings<sup>686</sup>:  $EER = (-0.02 * SEER^2) + (1.12 * SEER)$

= Actual installed

3.412 = Btu per Wh.

$COP_{exist}$  = coefficient of performance of the existing equipment  
 = Actual. If unknown assume 1.0 COP for PTAC units and 2.9 COP for PTHPs<sup>687</sup>

$COP_{base}$  = coefficient of performance of the baseline equipment; see table above for values.

$COP_{ee}$  = coefficient of performance of the energy efficient equipment.  
 = Actual installed.

<sup>685</sup> Efficiency of existing unit is estimated based on the 2012 IECC building energy code standard sized, and assuming a 1 ton unit; PTAC:  $EER = 13.8 - (0.3 * 12,000/1,000) = 10.2$ , and PTHP:  $EER = 14 - (0.3 * 12,000/1,000) = 10.4$ .

<sup>686</sup> Based on Wassmer, M. (2003). A Component-Based Model for Residential Air Conditioner and Heat Pump Energy Calculations. Masters Thesis, University of Colorado at Boulder. Note this is appropriate for single speed units only.

<sup>687</sup> Efficiency of existing unit is estimated based on the 2012 IECC building energy code, and assuming a 1 ton unit;  $COP = 3.2 - (0.026 * 12,000/1,000) = 2.9$ .

FossilEff<sub>base</sub> = Efficiency of baseline or existing fossil fuel heating system  
= Actual or select baseline from applicable measure in Section 4.

**Time of Sale (assuming new construction baseline):**

**For example**, a 1 ton PTAC with an efficient EER of 12 in a guest room of a hotel in Rockford with a building permit dated after 1/1/2016 saves:

$$= [(12) * [(1/10.4) - (1/12)] * 1,042]$$
$$= 160 \text{ kWh}$$

**Early Replacement (assuming replacement baseline for deferred replacement in 3 years):**

**For example**, a 1 ton PTHP with an efficient EER of 12, COP of 3.0 in a guest room of a hotel in Rockford replaces a PTAC unit (with electric resistance heat) with unknown efficiency.

$\Delta$ kWh for remaining life of existing unit (1<sup>st</sup> 3 years)

$$= (12 * (1/10.2 - 1/12) * 1,042) + (12/3.412 * (1/1.0 - 1/3.0) * 1,758)$$
$$= 184 + 4,122$$
$$= 4,306 \text{ kWh}$$

$\Delta$ kWh for remaining measure life (next 5 years)

$$= (12 * (1/10.4 - 1/12) * 1,042) + (12/3.412 * (1/1.0 - 1/3.0) * 1,758)$$
$$= 160 + 4,122$$
$$= 4,282 \text{ kWh}$$

**For example**, a 1 ton PTHP with an efficient EER of 12, COP of 3.0 in a guest room of a hotel in Rockford in place of a 80% central boiler providing heat and a baseline PTAC.

$$\begin{aligned} \text{SiteEnergySavings (MMBTUs)} &= \text{FuelSwitchSavings} + \text{NonFuelSwitchSavings} \\ \text{FuelSwitchSavings} &= (\text{GasHeatReplaced} - \text{ElectricHeatConsumed}) \\ \text{NonFuelSwitchSavings} &= \text{CoolingImpact} \\ \text{GasHeatReplaced} &= (\text{HeatLoad} * 1/\text{FossilEff}_{\text{base}}) / 1,000 \\ &= (12 * 1758 * 1/0.8) / 1,000 \\ &= 26.4 \text{ MMBtu} \\ \text{ElectricHeatConsumed} &= (\text{HeatLoad} * 1/\text{COP}_{\text{ee}}) / 1000 \\ &= (12 * 1758 * 1/3) / 1000 \\ &= 7.0 \text{ MMBtu} \\ \text{CoolingImpact} &= \text{CoolLoad} * (1/\text{EER}_{\text{base}} - 1/\text{EER}_{\text{ee}}) * 3,412/1,000,000 \\ &= 12 * 1,042 * (1/10.4 - 1/12) * 3412/1,000,000 \\ &= 0.5 \text{ MMBtu} \\ \text{SiteEnergySavings (MMBTUs)} &= 26.4 - 7.0 + 0.5 \\ &= 19.9 \text{ MMBtu} \end{aligned}$$

$$\begin{aligned} \text{If supported by an electric utility: } \Delta\text{kWh} &= \Delta\text{SiteEnergySavings} * 1,000,000 / 3,412 \\ &= 19.9 * 1,000,000/3,412 \\ &= 5,832 \text{ kWh} \end{aligned}$$

### SUMMER COINCIDENT PEAK DEMAND SAVINGS

Time of Sale:

$$\Delta\text{kW} = (\text{kBtu}/\text{hr}_{\text{cool}}) * [(1/\text{EER}_{\text{base}}) - (1/\text{EER}_{\text{ee}})] * \text{CF}$$

Early Replacement:

$$\Delta\text{kW for remaining life of existing unit (1}^{\text{st}} \text{ 5 years)} = (\text{kBtu}/\text{hr}_{\text{cool}}) * [(1/\text{EER}_{\text{exist}}) - (1/\text{EER}_{\text{ee}})] * \text{CF}$$

$$\Delta\text{kW for remaining measure life (next 10 years)} = (\text{kBtu}/\text{hr}_{\text{cool}}) * [(1/\text{EER}_{\text{base}}) - (1/\text{EER}_{\text{ee}})] * \text{CF}$$

Where:

$$\begin{aligned} \text{CF}_{\text{SSP}} &= \text{Summer System Peak Coincidence Factor for Commercial cooling (during system peak hour)} \\ &= 91.3\% \text{ }^{688} \end{aligned}$$

$$\text{CF}_{\text{PJM}} = \text{PJM Summer Peak Coincidence Factor for Commercial cooling (average during peak period)}$$

<sup>688</sup> Based on analysis of Itron eShape data for Missouri, calibrated to Illinois loads, supplied by Ameren. The AC load during the utility's peak hour is divided by the maximum AC load during the year.

$$= 47.8\%^{689}$$

**Time of Sale:**

**For example**, a 1 ton replacement cooling unit with no heating with an efficient EER of 12 with a building permit dated after 1/1/2016 saves:

$$\begin{aligned} \Delta kW_{SSP} &= (12 * (1/10.4 - 1/12)) * 0.913 \\ &= 0.1405 \text{ kW} \end{aligned}$$

**For example**, a 1 ton PTHP with an efficient EER of 12, COP of 3.0 replacing a PTAC unit with unknown efficiency saves:

$\Delta kW$  for remaining life of existing unit (1<sup>st</sup> 3 years):

$$\begin{aligned} \Delta kW_{SSP} &= 12 * (1/10.2 - 1/12) * 0.913 \\ &= 0.1611 \text{ kW} \end{aligned}$$

$\Delta kW$  for remaining measure life (next 5 years):

$$\begin{aligned} \Delta kW_{SSP} &= 12 * (1/10.4 - 1/12) * 0.913 \\ &= 0.1405 \text{ kW} \end{aligned}$$

**FOSSIL FUEL SAVINGS**

Calculation provided together with Electric Energy Savings above.

**WATER IMPACT DESCRIPTIONS AND CALCULATION**

N/A

**DEEMED O&M COST ADJUSTMENT CALCULATION**

N/A

**COST EFFECTIVENESS SCREENING AND LOAD REDUCTION FORECASTING WHEN FUEL SWITCHING**

This measure can involve fuel switching from fossil fuel to electric.

For the purposes of forecasting load reductions due to fuel switch projects per Section 16-111.5B, changes in site energy use at the customer’s meter (using  $\Delta kWh$  algorithm below), customer switching estimates, NTG, and any other adjustment factors deemed appropriate, should be used.

The inputs to cost effectiveness screening should reflect the actual impacts on the electric and fuel consumption at the customer meter and, for fuel switching measures, should therefore reflect the decrease in one fuel and increase in another, as opposed to the single savings value calculated in the “Electric and Fossil Fuel Energy Savings” section above. Therefore in addition to the calculation of savings claimed, the following values should be used to assess the cost effectiveness of the measure.

$$\begin{aligned} \Delta \text{Therms} &= [\text{Gas Heat Replaced}] \\ &= (\text{HeatLoad} * 1/\text{FossilEff}_{\text{base}}) / 100 \\ \Delta kWh &= - [\text{Electric Heat Added}] + [\text{CoolingImpact}] \\ &= -((\text{HeatLoad} * 1/\text{COP}_{\text{ee}}) / 3.412) + (\text{CoolLoad} * (1/\text{EER}_{\text{base}} - 1/\text{EER}_{\text{ee}})) \end{aligned}$$

<sup>689</sup> Based on analysis of Itron eShape data for Missouri, calibrated to Illinois loads, supplied by Ameren. The average AC load over the PJM peak period (1-5pm, M-F, June through August) is divided by the maximum AC load during the year.



**MEASURE CODE: CI-HVC-PTAC-V12-230101**

**REVIEW DEADLINE: 1/1/2026**

## 4.4.14 Pipe Insulation

### DESCRIPTION

This measure provides rebates for installation of 1” – 4” fiberglass, foam, calcium silicate or other types of insulation with similar insulating properties to existing bare pipe on straight piping as well as other pipe components such as elbows, tees, valves, and flanges for all non-residential installations.

Savings are provided in two forms; default savings estimates on a per linear foot basis and savings calculated with a multitude of varying parameters with the use of an external calculator<sup>690</sup>. The default savings estimates are provided in the ‘Calculation of Savings’ section below. They provide estimated savings for measure applications with select and default parameters. The external tool, however, allows more flexibility and provides comprehensive analysis to pipe insulation projects, taking into account all on-site variables.

Default per linear foot savings estimates are provided for the both exposed indoor or above ground outdoor piping distributing fluid in the following system types (natural gas fired systems only):

- Hydronic heating systems (with or without outdoor reset controls), including:
  - boiler systems that do not circulate water around a central loop and operate upon demand from a thermostat (“non-recirculation”)
  - systems that recirculate during heating season only (“Recirculation – heating season only”)
  - systems recirculating year-round (“Recirculation – year-round”)
- Domestic hot water
- Low and high-pressure steam systems
  - non-recirculation
  - recirculation - heating season only
  - recirculation - year round

With the use of the external tool to account for varying parameter inputs, savings are calculated using the “Pipe Insulation” calculator available on the Nicor Gas website at: <https://www.nicorgas.com/emerging>. Savings are approached through the following inputs:

- Pipe Material: Copper, Steel, Stainless Steel
- Pipe Location: Indoor (Heated, Semi-Heated,<sup>691</sup> Unheated, Unspecified) or Outdoor
- Application: Hot Water Space Heating, Steam (5, 15, 40, 65, 100, 150 psi) for various system types detailed in the subsequent system type list below
- Thermal Regain Factor (based on pipe location)
- Building Type<sup>692</sup>
- Nominal Pipe Size (inches)
- Insulation Thickness (inches): 1”-4”, specified in ½” increments<sup>693</sup>
- Hot Water/Steam Boiler Efficiency (%): 75%-90%, specified in 2.5% increments
- Climate Zone: Rockford, Chicago, Springfield, Belleville, Marion
- Length of Installed Pipe (feet)
- Number of Elbows, Tees, Flanges, and/or Valves<sup>694</sup>

<sup>690</sup> Please see; ‘C&I Pipe Insulation Calculator Access.docx’ for directions on accessing the external calculator. The use of other comparable external calculators are allowed if the functionality mirrors the savings approach detailed in this characterization.

<sup>691</sup> Unconditioned space with heat transfer to conditioned space (e.g. boiler room, ceiling plenum, basement, crawlspace, wall, etc.).

<sup>692</sup> Comprehensive list of building types available in Section 4.4, HVAC End Use of IL TRM.

<sup>693</sup> For insulation thicknesses greater than 4”, savings can be claimed based on 4” insulation thickness.

<sup>694</sup> Equivalent length of elbows and tees is based on methodology described in ANSI/ASME B36.19. Equivalent length of flanges and valves is based on methodology described in ATSM Standard C1129-12.

Process piping can also use the algorithms provided but requires custom entry of hours.

For new construction applications, minimum qualifying nominal pipe diameter is 1”. Piping must have at least 1” of insulation and outdoor piping must include an all-weather protective jacket. New advanced insulating materials may be thinner, and savings can be calculated with 3E Plus v4.1.

The relevant code of compliance should be followed for direction on minimum permitted insulation thickness for a nominal pipe diameter. As per the International Energy Conservation Code (IECC) 2021, the minimum permitted insulation thickness is 1” for installations pertaining to new construction or major renovation heating HVAC applications<sup>695</sup>. However, there are exceptions based on Fluid Operating Temperature Range, Insulation thermal conductivity range, install locations and pipe sizes –indicating the minimum insulation thickness required for parameters described in the column headers presented in the table below.

Fluid Operating Temperature Range and Usage (°F)	Insulation Conductivity		Nominal Pipe or Tube Size (inches)				
	Conductivity Btu.in/(h.ft <sup>2</sup> .°F)	Mean Rating Temperature, °F	<1	1 to <1.5	1.5 to <4	4 to <8	≥8
>350	0.32 - 0.34	250	4.5	5.0	5.0	5.0	5.0
251 - 350	0.29 - 0.32	200	3.0	4.0	4.5	4.5	4.5
201 - 250	0.27 - 0.30	150	2.5	2.5	2.5	3.0	3.0
141 - 200	0.25 - 0.29	125	1.5	1.5	2.0	2.0	2.0
105 - 140	0.21 - 0.28	100	1.0	1.0	1.5	1.5	1.5
40 -60	0.21 - 0.27	75	0.5	0.5	1.0	1.0	1.0
<40	0.20 - 0.26	50	0.5	1.0	1.0	1.0	1.5

Note – The above table is not representative of the applicability of the workpaper measure and does not reflect any limitations in the web-based calculator. This is merely the requirements cited by the IECC 2018 code for pipe insulation.

This measure was developed to be applicable to the following program types: RF, DI

If applied to other program types, the measure savings should be verified.

**DEFINITION OF EFFICIENT EQUIPMENT**

The efficient case is installing pipe wrap insulation to a length of pipe. Indoor piping must have at least 1” of insulation (or equivalent R-value) and outdoor piping must have at least 2” of insulation (or equivalent R-value) and include an all-weather protective jacket. Minimum qualifying pipe diameter is 1.” Insulation must be continuous and contiguous over fittings that directly connect to straight pipe, including elbows and tees.<sup>696</sup>

**DEFINITION OF BASELINE EQUIPMENT**

The base case for savings estimates is a bare pipe. Pipes are required by new construction code to be insulated but are still commonly found uninsulated in older commercial buildings.

**DEEMED LIFETIME OF EFFICIENT EQUIPMENT**

The measure life is assumed to be 15 years.<sup>697</sup>

<sup>695</sup> International Energy Conservation Code, 2018; Section C403.11.3 Piping Insulation (Mandatory), Table C403.11.3, Page C-69.

<sup>696</sup> ASHRAE Handbook—Fundamentals, 23.14; Hart, G., “Saving energy by insulating pipe components on steam and hot water distribution systems”, ASHRAE Journal, October 2011.

<sup>697</sup> Measure Life Report, Residential and Commercial/Industrial Lighting and HVAC Measures, GDS Associates, June 2007.

**DEEMED MEASURE COST**

Actual costs should be used if known. Otherwise, the deemed measure costs below based on RS Means<sup>698</sup> pricing reference materials may be used.<sup>699</sup> The following table summarizes the estimated costs for this measure per foot of insulation added and include installation costs:

Insulation Thickness				
	1 Inch	1.5 Inches	2 Inches	2.5 Inches
Pipe- RS Means #	220719.10.5140	220719.10.4900	220719.10.4900	Extrapolated
Jacket- RS Means #	220719.30.0152 & 220719.40.0240	220719.30.0140 & 220719.40.0140	220719.30.0140 & 220719.40.0140	220719.30.0140 & 220719.40.0140
Pipe Insulation Type	Calcium Silicate	Calcium Silicate	Calcium Silicate	Calcium Silicate
Jacket Type (Indoor)	PVC	PVC	PVC	PVC
Jacket Type (Outdoor)	Aluminum	Aluminum	Aluminum	Aluminum
Insulation Cost per foot [1]	\$11.45	\$15.73	\$20.23	\$24.58
Jacket Cost per foot (Indoor) [2]	\$4.90	\$6.70	\$6.70	\$6.70
Jacket Cost per foot (Outdoor) [3]	\$6.75	\$9.27	\$9.27	\$9.27
<b>Total Cost per foot (Indoor) = [1+2]</b>	<b>\$16.35</b>	<b>\$22.43</b>	<b>\$26.93</b>	<b>\$31.28</b>
<b>Total Cost per foot (Outdoor) = [1+3]</b>	<b>\$18.20</b>	<b>\$25.00</b>	<b>\$29.50</b>	<b>\$33.85</b>

Insulation Thickness (continued)			
	3 Inches	3.5 Inches	4 Inches
Pipe- RS Means #	220719.10.4900	Extrapolated	Extrapolated
Jacket- RS Means #	220719.30.0140 & 220719.40.0140	220719.30.0140 & 220719.40.0140	220719.30.0140 & 220719.40.0140
Pipe Insulation Type	Calcium Silicate	Calcium Silicate	Calcium Silicate
Jacket Type (Indoor)	PVC	PVC	PVC
Jacket Type (Outdoor)	Aluminum	Aluminum	Aluminum
Insulation Cost per foot [1]	\$28.92	\$33.32	\$37.70
Jacket Cost per foot (Indoor) [2]	\$6.70	\$6.70	\$6.70
Jacket Cost per foot (Outdoor) [3]	\$9.27	\$9.27	\$9.27
<b>Total Cost per foot (Indoor) = [1+2]</b>	<b>\$35.62</b>	<b>\$40.02</b>	<b>\$44.40</b>
<b>Total Cost per foot (Outdoor) = [1+3]</b>	<b>\$38.19</b>	<b>\$42.59</b>	<b>\$46.97</b>

**LOADSHAPE**

N/A

**COINCIDENCE FACTOR**

N/A

---

**Algorithm**

---

<sup>698</sup> RS Means 2008. Mechanical Cost Data, pages 106 to 119

<sup>699</sup> RS Means 2010: “for fittings, add 3 linear feet for each fitting plus 4 linear feet for each flange of the fitting”

**CALCULATION OF SAVINGS**

**ELECTRIC ENERGY SAVINGS**

N/A

**SUMMER COINCIDENT PEAK DEMAND SAVINGS**

N/A

**FOSSIL FUEL SAVINGS**

$$\begin{aligned} \Delta \text{therms per foot}^{700} &= [((Q_{\text{base}} - Q_{\text{eff}}) * \text{EFLH}) / (100,000 * \eta_{\text{Boiler}})] * \text{TRF} \\ &= [\text{Modeled or provided by tables below}] * \text{TRF} \\ \Delta \text{therms} &= (L_{\text{sp}} + L_{\text{oc},i}) * \Delta \text{therms per foot} \end{aligned}$$

Where:

EFLH = Equivalent Full Load Hours for Heating in Existing Buildings or New Construction  
 = Actual or defaults by building type provided in Section 4.4, HVAC end use  
 For year-round recirculation or domestic hot water:  
 = 8,766

For heating season recirculation, hours with the outside air temperature below 55°F:

Zone	Hours
Zone 1 (Rockford)	5,039
Zone 2 (Chicago)	4,963
Zone 3 (Springfield)	4,495
Zone 4 (Belleville/	4,021
Zone 5 (Marion)	4,150

$Q_{\text{base}}$  = Heat Loss from Bare Pipe (Btu/hr/ft)  
 = Calculated where possible using 3E Plusv4.1 software. For defaults see table below  
 $Q_{\text{eff}}$  = Heat Loss from Insulated Pipe (Btu/hr/ft)  
 = Calculated where possible using 3E Plusv4.1 software. For defaults see table below  
 100,000 = conversion factor (1 therm = 100,000 Btu)  
 $\eta_{\text{Boiler}}$  = Efficiency of the boiler being used to generate the hot water or steam in the pipe  
 = Actual or if unknown use default values given below:  
 = 81.9% for water boilers<sup>701</sup>  
 = 80.7% for steam boilers, except multifamily low-pressure<sup>702</sup>

<sup>700</sup>This value comes from the reference table “Savings Summary by Building Type and System Type.” The formula and the input tables in this section document assumptions used in calculation spreadsheet “Pipe Insulation Savings 2013-11-12.xlsx”.

<sup>701</sup> Average efficiencies of units from the California Energy Commission (CEC).

<sup>702</sup> Ibid.

= 64.8% for multifamily low-pressure steam boilers <sup>703</sup>

TRF = Thermal Regain Factor for pipe location and use, see table below. The Custom TRF option may be used on any pipe location, including pipe locations with deemed TRFs specifically listed in the table below, if supporting justification and calculations for the Custom TRF are provided.

May vary seasonally such as: TRF[summer] \* summer hours + TRF[winter] \* winter hours where TRF values reflecting summer and winter conditions are apportioned by the hours for those conditions. TRF may also be adjusted by building specific balance point temperature (BPT) and operating hours above and below that BPT.<sup>704</sup>

Pipe Location	Assumed Regain	TRF, Thermal Regain Factor
Outdoor	0%	1.0
Indoor, conditioned space during the heating season, 55°F BPT	85%	0.15
Indoor, conditioned space, not during the heating season, 55°F BPT	0%	1.0
Indoor, conditioned, annual use (e.g., hot water or process loads), 55°F BPT	45%	0.55
Indoor, semi- conditioned, (unconditioned space, with heat transfer to conditioned space. E.g., boiler room, ceiling plenum, basement, crawlspace, wall), during the heating season, 55°F BPT	30%	0.70
Indoor, semi-conditioned, not during the heating season, 55°F BPT	0%	1.0
Indoor, semi-conditioned, annual use, 55°F BPT	16%	0.84
Indoor, unconditioned spaces, (no heat transfer to conditioned space)	0%	1.0
Location not specified - Commercial	23%	0.77
Location not specified – Industrial	16%	0.84
Custom	Custom	1 – assumed regain

L<sub>sp</sub> = Length of straight pipe to be insulated (linear foot)  
 = actual installed (linear foot)

L<sub>oc,l</sub> = Total equivalent length of the other components (valves and tees) of pipe to be insulated  
 = Actual installed (linear foot). See table “Equivalent Length of Other Components – Elbows and Tees” for equivalent lengths.

The heat loss estimates (Q<sub>base</sub> and Q<sub>eff</sub>) were developed using the 3E Plus v4.1 software program.<sup>705</sup> The energy savings analysis is based on adding 1-inch (indoor) or 2-inch (outdoor) thick insulation around bare pipe. The thermal conductivity of pipe insulation varies by material and temperature rating; to obtain a typical value, a range of

<sup>703</sup> Katrakis, J. and T.S. Zawacki. “Field-Measured Seasonal Efficiency of Intermediate-sized Low-Pressure Steam Boilers”. ASHRAE V99, pt. 2, 1993.

<sup>704</sup> Zimmerman, Cliff, Franklin Energy, “Thermal Regain Factor\_4-30-14.docx”, 2014. Based on climate zone 2. Note ‘Location not specified – Commercial’ assumes semi-conditioned spaces with 50% pipes providing space heating and 50% providing DHW. ‘Location not specified – Commercial’ assumes semi-conditioned annual usage.

<sup>705</sup> 3E Plus is a heat loss calculation software provided by the NAIMA (North American Insulation Manufacturer Association).

materials allowed for this measure were averaged. For insulation materials not in the table below, use 3E Plusv4.0 software to calculate  $Q_{base}$  and  $Q_{eff}$ .

Insulation Type	Conductivity (Btu.in / hr.ft <sup>2</sup> .°F @ 75F)	Max temp (°F)
Polyethylene foam	0.25	200
Flexible polyurethane-based foam	0.27	200
Fiberglass	0.31	250
Melamine foam	0.26	350
Flexible silicon foam	0.40	392
Calcium silicate	0.40	1200
Cellular glass	0.31	400
Average conductivity of all these materials (Btu.in / hr.ft <sup>2</sup> .°F @ 75°F)	0.31	

The pipe fluid temperature assumption used depends upon both the system type and whether there are outdoor reset controls:

System Type	Fluid temperature assumption (°F)
Hot Water space heating with outdoor reset - Non recirculation	145
Hot Water space heating without outdoor reset - Non recirculation	170
Hot Water space heating with outdoor reset – Recirculation heating season only	145
Hot Water space heating without outdoor reset – Recirculation heating season only	170
Hot Water space heating with outdoor reset – Recirculation year-round	130
Hot Water space heating without outdoor reset – Recirculation year-round	170
Domestic Hot Water	125
5 psi Steam (low pressure)	225
15 psi Steam (low pressure)	250
40 psi Steam (low pressure)	287
65 psi Steam (high pressure)	312
100 psi Steam (high pressure)	338
150 psi Steam (high pressure)	365

Example System Types	Indoor Insulation, Hot Water	Indoor Insulation, 5 psi Steam	Indoor Insulation, 65 psi Steam	Domestic Hot Water	Outdoor Insulation, Hot Water	Outdoor Insulation, 5 psi Steam	Outdoor Insulation, 65 psi Steam
Insulation thickness (inch)	1	2	2.5	1	3	3.5	4
Temperature, Fluid in Pipe (°F)	170 (w/o reset) 145 (w/ reset heat) 130 (w/reset year)	225	312	125	170 (w/o reset) 145 (w/ reset heat) 130 (w/reset year)	225	312
Climate Zone	Climate Zone 2: Chicago						
Building Type	Office – Mid Rise						
Operating Time (hrs/yr)	1,629 (non-recirc) 4,963 (recirc heating season) 8,766 (recirc year-round)						
Ambient Temperature (°F) <sup>706</sup>	75	75	75	75	48.6	48.6	48.6
Wind speed (mph) <sup>707</sup>	0	0	0	0	5.0	5.0	5.0
Boiler / Water Heater efficiency	75%	80%	85%	67%	80%	85%	90%
Pipe parameters							
Pipe Location	Indoor Heated	Indoor Semi-heated	Indoor Unheated	n/a	Outdoor		
Pipe material	Copper	Steel	Stainless Steel	Copper	Copper	Steel	Stainless Steel
Length of Pipe (ft)	100						
Pipe size for Heat Loss Calc	2"	2"	2"	2"	2"	2"	2"
Outer Diameter, Pipe, actual	2.38"	2.38"	2.38"	2.38"	2.38"	2.38"	2.38"
Heat Loss, Bare Pipe (from 3EPlus) (Btu/hr-ft)	113.5 (w/o reset) 77.8 (w/ reset heat) 58 (w/reset year)	232.2	286.3	52	460.2 (w/o reset) 363.4 (w/ reset heat) 306 (w/reset year)	709.5	942.2
Insulation parameters							
Average Heat Loss, Insulation (from 3EPlus) (Btu/hr-ft)	21.6 (w/o reset) 15.8 (w/ reset heat) 12.4 (w/reset year)	22.6	31.8	13.25	15.2 (w/o reset) 12.1 (w/ reset heat) 10.2 (w/reset year)	20.4	28.2

<sup>706</sup> DOE Weather Data, TMY3 (Typical Meteorological Year), developed by NREL for the average ambient temperature for Aurora, IL.

<sup>707</sup> DOE Weather Data, TMY3 (Typical Meteorological Year), developed by NREL for the average ambient temperature for Aurora, IL.



Example System Types	Indoor Insulation, Hot Water	Indoor Insulation, 5 psi Steam	Indoor Insulation, 65 psi Steam	Domestic Hot Water	Outdoor Insulation, Hot Water	Outdoor Insulation, 5 psi Steam	Outdoor Insulation, 65 psi Steam
<b>Annual Energy Savings/ft</b>							
Annual Gas Use, Base Case (therms/yr/ft)	2.46 (w/o reset) 5.15 (w/ reset heat) 6.78 (w/reset year)	4.73 (non recirc) 14.4 (recirc heat) 25.4 (recirc year)	5.5 (non recirc) 16.7 (recirc heat) 29.5 (recirc year)	6.76	9.37 (w/o reset) 22.5 (w/ reset heat) 33.5 (w/reset year)	13.6 (non recirc) 41.4 (recirc heat) 73.2 (recirc year)	17.1 (non recirc) 52.0 (recirc heat) 91.8 (recirc year)
Annual Gas Use, Measure case (therms/yr/ft)	0.46 (w/o reset) 1.05 (w/ reset heat) 1.48 (w/reset year)	0.43 (non recirc) 1.4 (recirc heat) 2.4 (recirc year)	0.6 (non recirc) 1.8 (recirc heat) 3.2 (recirc year)	1.73	0.3 (w/o reset) 0.7 (w/ reset heat) 1.1 (w/reset year)	0.4 (non recirc) 1.2 (recirc heat) 2.1 (recirc year)	0.6 (non recirc) 1.6 (recirc heat) 2.8 (recirc year)
Annual Gas Savings (therms/yr/ft)	2.0 (w/o reset) 4.1 (w/ reset heat) 5.3 (w/reset year)	4.3 (non recirc) 13.0 (recirc heat) 23.0 (recirc year)	4.9(non recirc) 14.9 (recirc heat) 26.3 (recirc year)	5.02	9.1 (w/o reset) 21.8 (w/ reset heat) 32.4 (w/reset year)	13.2 (non recirc) 40.2 (recirc heat) 71.1 (recirc year)	16.5 (non recirc) 50.4 (recirc heat) 89 (recirc year)
<b>Elbows, Tees, Flanges, &amp; Valves</b>							
Number of Elbows	5	10	20	n/a	5	10	20
Number of Tees	5	10	20	n/a	5	10	20
Number of Flanges	5	10	20	n/a	5	10	20
Number of Valves	5	10	20	n/a	5	10	20
<b>Annual Energy Savings</b>							
Total Gas Savings (therms/yr)	39 (w/o reset) 80 (w/ reset heat) 104 (w/reset year)	478 (non recirc) 1,456 (recirc heat) 2,571 (recirc year)	1,072 (non recirc) 3,267 (recirc heat) 5,770 (recirc year)	502	930 (w/o reset) 2,832 (w/ reset heat) 4,211 (w/reset year)	2,112 (non recirc) 6,434 (recirc heat) 11,364 (recirc year)	3,635 (non recirc) 11,074 (recirc heat) 19,560 (recirc year)

Heat = heating season only, year = year round

Values below must be multiplied by the appropriate Thermal Regain Factor (TRF). All variables were the same except for hours of operation in the calculation of the default savings per foot for the various building types and applications as presented in the table below:

**Savings Summary for Indoor pipe insulation by System Type and Building Type (Δtherms per foot)  
(continues for 3.5 pages)**

Location	System Type	Building Type	Annual therm Savings per linear foot (therm /ft) (2" pipe / 1" insulation for hot water, 2" insulation for steam)				
			Zone 1 (Rockford)	Zone 2 (Chicago)	Zone 3 (Springfield)	Zone 4 (Belleville)	Zone 5 (Marion)
Indoor	Hot Water Space Heating with outdoor reset – non-recirculation	Assembly	1.32	1.36	1.21	0.81	1.24
		Assisted Living	1.25	1.22	1.07	0.79	0.95
		College	1.13	1.06	0.95	0.53	0.63
		Convenience Store	1.10	1.01	0.90	0.65	0.72
		Elementary School	1.32	1.29	1.13	0.78	0.95
		Garage	0.73	0.72	0.63	0.50	0.56
		Grocery	1.19	1.19	1.04	0.65	0.78
		Healthcare Clinic	1.17	1.20	1.05	0.71	0.75
		High School	1.37	1.38	1.23	0.88	1.03
		Hospital - CAV no econ	1.31	1.35	1.15	0.99	1.12
		Hospital - CAV econ	1.33	1.37	1.17	1.01	1.15
		Hospital - VAV econ	0.54	0.51	0.39	0.23	0.25
		Hospital - FCU	0.98	1.12	0.91	1.07	1.44
		Hotel/Motel	1.31	1.27	1.14	0.78	0.96
		Hotel/Motel - Common	1.19	1.21	1.15	0.93	0.98
		Hotel/Motel - Guest	1.30	1.26	1.13	0.75	0.93
		Manufacturing Facility	0.78	0.75	0.70	0.42	0.47
		MF - High Rise	1.13	1.12	1.02	0.87	0.87
		MF - High Rise - Common	1.35	1.31	1.17	0.81	1.04
		MF - High Rise - Residential	1.09	1.08	0.99	0.85	0.83
		MF - Mid Rise	1.23	1.25	1.07	0.79	0.90
		Movie Theater	1.35	1.33	1.24	0.94	1.12
		Office - High Rise - CAV no econ	1.50	1.52	1.38	0.93	1.01
		Office - High Rise - CAV econ	1.55	1.58	1.45	1.00	1.10
		Office - High Rise - VAV econ	1.13	1.15	0.95	0.56	0.63
		Office - High Rise - FCU	0.83	0.82	0.71	0.37	0.39
		Office - Low Rise	1.06	1.06	0.84	0.51	0.59
		Office - Mid Rise	1.17	1.18	0.99	0.63	0.70
		Religious Building	1.19	1.11	1.07	0.78	0.89
		Restaurant	1.00	1.00	0.90	0.68	0.81
		Retail - Department Store	1.03	0.95	0.89	0.58	0.66
		Retail - Strip Mall	0.99	0.91	0.81	0.56	0.60
Warehouse	1.08	1.01	1.04	0.65	0.80		
Unknown	1.15	1.14	1.01	0.73	0.84		

			Annual therm Savings per linear foot (therm /ft) (2" pipe / 1" insulation for hot water, 2" insulation for steam)				
Location	System Type	Building Type	Zone 1 (Rockford)	Zone 2 (Chicago)	Zone 3 (Springfield)	Zone 4 (Belleville)	Zone 5 (Marion)
Indoor	Hot Water Space Heating without outdoor reset – non-recirculation	Assembly	1.96	2.00	1.79	1.19	1.83
		Assisted Living	1.84	1.80	1.58	1.16	1.40
		College	1.67	1.56	1.40	0.78	0.93
		Convenience Store	1.62	1.50	1.33	0.95	1.06
		Elementary School	1.95	1.90	1.68	1.16	1.40
		Garage	1.08	1.06	0.93	0.74	0.82
		Grocery	1.76	1.75	1.54	0.96	1.15
		Healthcare Clinic	1.73	1.77	1.55	1.05	1.11
		High School	2.02	2.03	1.82	1.30	1.52
		Hospital - CAV no econ	1.93	1.99	1.69	1.46	1.65
		Hospital - CAV econ	1.96	2.03	1.73	1.50	1.70
		Hospital - VAV econ	0.80	0.76	0.57	0.34	0.37
		Hospital - FCU	1.45	1.65	1.35	1.58	2.13
		Hotel/Motel	1.93	1.87	1.69	1.16	1.41
		Hotel/Motel - Common	1.75	1.78	1.69	1.38	1.45
		Hotel/Motel - Guest	1.92	1.86	1.66	1.11	1.37
		Manufacturing Facility	1.15	1.11	1.03	0.62	0.69
		MF - High Rise	1.67	1.65	1.50	1.28	1.28
		MF - High Rise - Common	1.99	1.93	1.73	1.19	1.54
		MF - High Rise - Residential	1.61	1.60	1.46	1.26	1.23
		MF - Mid Rise	1.82	1.84	1.59	1.17	1.33
		Movie Theater	1.99	1.96	1.83	1.39	1.66
		Office - High Rise - CAV no econ	2.21	2.24	2.04	1.37	1.49
		Office - High Rise - CAV econ	2.29	2.33	2.14	1.48	1.63
		Office - High Rise - VAV econ	1.67	1.70	1.40	0.83	0.93
		Office - High Rise - FCU	1.22	1.21	1.04	0.55	0.58
		Office - Low Rise	1.56	1.56	1.24	0.76	0.87
		Office - Mid Rise	1.73	1.74	1.47	0.94	1.04
	Religious Building	1.75	1.65	1.58	1.15	1.32	
	Restaurant	1.48	1.48	1.33	1.01	1.19	
	Retail - Department Store	1.52	1.40	1.31	0.85	0.97	
	Retail - Strip Mall	1.46	1.35	1.19	0.82	0.89	
	Warehouse	1.59	1.49	1.53	0.96	1.18	
Unknown	1.70	1.68	1.50	1.07	1.25		
Hot Water with outdoor reset	All buildings, Recirculation heating season only (Hours below 55F)	3.73	3.68	3.33	2.98	3.08	
Hot Water w/o outdoor reset	All buildings, Recirculation heating season only (Hours below 55F)	5.51	5.43	4.92	4.40	4.54	
Hot Water with outdoor reset	All buildings, Recirculation year round (All hours)	4.79	4.79	4.79	4.79	4.79	
Hot Water w/o outdoor reset	All buildings, Recirculation year round (All hours)	9.58	9.58	9.58	9.58	9.58	
Domestic Hot Water	DHW circulation loop	5.02	5.02	5.02	5.02	5.02	

Location	System Type	Building Type	Annual therm Savings per linear foot (therm /ft) (2" pipe / 1" insulation for hot water, 2" insulation for steam)				
			Zone 1 (Rockford)	Zone 2 (Chicago)	Zone 3 (Springfield)	Zone 4 (Belleville)	Zone 5 (Marion)
	LP Steam – non-recirculation	Assembly	4.25	4.36	3.89	2.59	3.97
		Assisted Living	4.01	3.92	3.44	2.53	3.04
		College	3.64	3.40	3.04	1.69	2.02
		Convenience Store	3.52	3.26	2.89	2.07	2.32
		Elementary School	4.24	4.13	3.64	2.52	3.05
		Garage	2.34	2.31	2.03	1.62	1.79
		Grocery	3.83	3.81	3.34	2.08	2.49
		Healthcare Clinic	3.76	3.85	3.36	2.29	2.42
		High School	4.39	4.42	3.96	2.82	3.30
		Hospital - CAV no econ	4.20	4.33	3.69	3.17	3.60
		Hospital - CAV econ	4.25	4.41	3.76	3.26	3.70
		Hospital - VAV econ	1.74	1.65	1.24	0.75	0.81
		Hospital - FCU	3.15	3.60	2.93	3.44	4.63
		Hotel/Motel	4.19	4.07	3.67	2.51	3.07
		Hotel/Motel - Common	3.81	3.87	3.68	3.00	3.15
		Hotel/Motel - Guest	4.18	4.05	3.62	2.42	2.98
		Manufacturing Facility	2.49	2.41	2.23	1.35	1.51
		MF - High Rise	4.52	4.46	4.07	3.46	3.47
		MF - High Rise - Common	5.38	5.22	4.68	3.23	4.17
		MF - High Rise - Residential	4.37	4.34	3.94	3.41	3.33
		MF - Mid Rise	4.94	4.99	4.30	3.16	3.60
		Movie Theater	4.33	4.26	3.98	3.03	3.61
		Office - High Rise - CAV no econ	4.81	4.88	4.45	2.98	3.24
		Office - High Rise - CAV econ	4.97	5.07	4.66	3.21	3.54
		Office - High Rise - VAV econ	3.64	3.71	3.06	1.81	2.01
		Office - High Rise - FCU	2.66	2.62	2.27	1.20	1.26
		Office - Low Rise	3.40	3.39	2.69	1.65	1.89
		Office - Mid Rise	3.77	3.78	3.19	2.03	2.26
		Religious Building	3.82	3.58	3.43	2.51	2.87
		Restaurant	3.21	3.22	2.89	2.19	2.60
	Retail - Department Store	3.31	3.04	2.86	1.86	2.12	
	Retail - Strip Mall	3.17	2.94	2.59	1.79	1.93	
	Warehouse	3.46	3.23	3.33	2.08	2.56	
	Unknown	3.70	3.66	3.26	2.34	2.71	
	LP Steam	All buildings, Recirculation heating season only (Hours below 55F)	11.99	11.81	10.70	9.57	9.88
	LP Steam	All buildings, Recirculation year round (All hours)	20.84	20.84	20.84	20.84	20.84

Location	System Type	Building Type	Annual therm Savings per linear foot (therm /ft) (2" pipe / 1" insulation for hot water, 2" insulation for steam)				
			Zone 1 (Rockford)	Zone 2 (Chicago)	Zone 3 (Springfield)	Zone 4 (Belleville)	Zone 5 (Marion)
	HP Steam – non-recirculation	Assembly	8.02	8.22	7.34	4.89	7.49
		Assisted Living	7.56	7.39	6.49	4.77	5.73
		College	6.87	6.42	5.73	3.18	3.81
		Convenience Store	6.65	6.14	5.45	3.91	4.37
		Elementary School	8.00	7.79	6.87	4.75	5.76
		Garage	4.42	4.35	3.82	3.05	3.38
		Grocery	7.22	7.19	6.30	3.93	4.70
		Healthcare Clinic	7.09	7.27	6.35	4.32	4.57
		High School	8.28	8.34	7.48	5.33	6.23
		Hospital - CAV no econ	7.92	8.16	6.95	5.98	6.79
		Hospital - CAV econ	8.03	8.32	7.09	6.14	6.98
		Hospital - VAV econ	3.28	3.12	2.35	1.41	1.53
		Hospital - FCU	5.95	6.79	5.53	6.50	8.73
		Hotel/Motel	7.91	7.69	6.93	4.74	5.79
		Hotel/Motel - Common	7.18	7.30	6.95	5.65	5.94
		Hotel/Motel - Guest	7.89	7.64	6.83	4.57	5.62
		Manufacturing Facility	4.70	4.55	4.22	2.55	2.84
		MF - High Rise	6.85	6.76	6.16	5.25	5.26
		MF - High Rise - Common	8.15	7.91	7.09	4.89	6.31
		MF - High Rise - Residential	6.62	6.57	5.97	5.17	5.04
		MF - Mid Rise	7.48	7.57	6.51	4.79	5.46
		Movie Theater	8.16	8.04	7.52	5.71	6.80
		Office - High Rise - CAV no econ	9.07	9.20	8.39	5.62	6.12
		Office - High Rise - CAV econ	9.38	9.57	8.80	6.06	6.67
		Office - High Rise - VAV econ	6.86	6.99	5.76	3.41	3.80
		Office - High Rise - FCU	5.02	4.95	4.27	2.27	2.38
		Office - Low Rise	6.41	6.40	5.08	3.11	3.56
		Office - Mid Rise	7.12	7.12	6.03	3.84	4.27
		Religious Building	7.20	6.75	6.46	4.73	5.41
		Restaurant	6.06	6.08	5.46	4.13	4.90
		Retail - Department Store	6.25	5.74	5.39	3.51	4.00
	Retail - Strip Mall	5.98	5.54	4.89	3.37	3.63	
	Warehouse	6.53	6.09	6.29	3.93	4.84	
	Unknown	6.97	6.91	6.14	4.41	5.11	
	HP Steam	All buildings, Recirculation heating season only (Hours below 55F)	22.62	22.28	20.18	18.05	18.63
	HP Steam	All buildings, Recirculation year round (All hours)	39.32	39.32	39.32	39.32	39.32

**Savings Summary for Outdoor pipe insulation by System Type and Building Type (Δtherms per foot)  
(continues for 3.5 pages)**

Location	System Type	Building Type	Annual therm Savings per linear foot (therm /ft) (2" pipe / 1" insulation for hot water, 2" insulation for steam)				
			Zone 1 (Rockford)	Zone 2 (Chicago)	Zone 3 (Springfield)	Zone 4 (Belleville)	Zone 5 (Marion)
Outdoor	Hot Water Space Heating with outdoor reset – non-recirculation	Assembly	5.61	5.75	5.14	3.42	5.24
		Assisted Living	5.28	5.17	4.54	3.34	4.01
		College	4.80	4.49	4.00	2.23	2.66
		Convenience Store	4.65	4.29	3.81	2.74	3.06
		Elementary School	5.59	5.45	4.81	3.32	4.03
		Garage	3.09	3.04	2.67	2.13	2.36
		Grocery	5.05	5.03	4.41	2.75	3.29
		Healthcare Clinic	4.96	5.08	4.44	3.03	3.20
		High School	5.79	5.83	5.23	3.72	4.36
		Hospital - CAV no econ	5.54	5.71	4.86	4.18	4.74
		Hospital - CAV econ	5.62	5.82	4.96	4.30	4.88
		Hospital - VAV econ	2.29	2.18	1.64	0.98	1.07
		Hospital - FCU	4.16	4.75	3.87	4.54	6.11
		Hotel/Motel	5.53	5.37	4.85	3.32	4.05
		Hotel/Motel - Common	5.02	5.11	4.86	3.95	4.15
		Hotel/Motel - Guest	5.52	5.34	4.77	3.20	3.93
		Manufacturing Facility	3.29	3.18	2.95	1.78	1.99
		MF - High Rise	4.80	4.73	4.31	3.67	3.68
		MF - High Rise - Common	5.70	5.54	4.96	3.42	4.41
		MF - High Rise - Residential	4.63	4.60	4.17	3.62	3.53
		MF - Mid Rise	5.23	5.29	4.55	3.35	3.82
		Movie Theater	5.71	5.62	5.25	4.00	4.76
		Office - High Rise - CAV no econ	6.34	6.44	5.87	3.93	4.28
		Office - High Rise - CAV econ	6.56	6.69	6.16	4.24	4.67
		Office - High Rise - VAV econ	4.80	4.89	4.03	2.38	2.66
		Office - High Rise - FCU	3.52	3.46	2.99	1.58	1.67
		Office - Low Rise	4.48	4.48	3.55	2.18	2.49
		Office - Mid Rise	4.98	4.98	4.22	2.69	2.98
		Religious Building	5.03	4.72	4.52	3.31	3.78
		Restaurant	4.24	4.26	3.82	2.89	3.43
	Retail - Department Store	4.37	4.01	3.77	2.45	2.80	
	Retail - Strip Mall	4.18	3.87	3.42	2.36	2.55	
	Warehouse	4.57	4.26	4.40	2.75	3.38	
	Unknown	4.88	4.83	4.30	3.09	3.57	
Hot Water Space Heating without outdoor reset – non-recirculation	Assembly	7.10	7.27	6.49	4.33	6.63	
	Assisted Living	6.69	6.53	5.74	4.22	5.08	
	College	6.08	5.68	5.07	2.81	3.37	
	Convenience Store	5.88	5.43	4.82	3.46	3.86	
	Elementary School	7.07	6.90	6.08	4.20	5.10	
	Garage	3.91	3.85	3.38	2.70	2.99	
	Grocery	6.39	6.36	5.58	3.48	4.16	
	Healthcare Clinic	6.27	6.44	5.62	3.83	4.05	
	High School	7.33	7.38	6.62	4.71	5.51	
	Hospital - CAV no econ	7.01	7.22	6.15	5.29	6.00	

			Annual therm Savings per linear foot (therm /ft) (2" pipe / 1" insulation for hot water, 2" insulation for steam)				
Location	System Type	Building Type	Zone 1 (Rockford)	Zone 2 (Chicago)	Zone 3 (Springfield)	Zone 4 (Belleville)	Zone 5 (Marion)
		Hospital - CAV econ	7.10	7.36	6.28	5.44	6.17
		Hospital - VAV econ	2.91	2.76	2.07	1.24	1.35
		Hospital - FCU	5.26	6.01	4.89	5.75	7.73
		Hotel/Motel	6.99	6.80	6.13	4.20	5.12
		Hotel/Motel - Common	6.36	6.46	6.15	5.00	5.25
		Hotel/Motel - Guest	6.99	6.76	6.04	4.05	4.97
		Manufacturing Facility	4.17	4.03	3.73	2.26	2.52
		MF - High Rise	6.06	5.98	5.45	4.64	4.65
		MF - High Rise - Common	7.21	7.00	6.28	4.33	5.58
		MF - High Rise - Residential	5.86	5.82	5.28	4.57	4.46
		MF - Mid Rise	6.62	6.70	5.76	4.24	4.83
		Movie Theater	7.22	7.11	6.65	5.05	6.02
		Office - High Rise - CAV no econ	8.02	8.15	7.42	4.97	5.42
		Office - High Rise - CAV econ	8.30	8.47	7.78	5.37	5.91
		Office - High Rise - VAV econ	6.07	6.19	5.10	3.01	3.36
		Office - High Rise - FCU	4.44	4.37	3.78	2.01	2.10
		Office - Low Rise	5.68	5.66	4.50	2.75	3.15
		Office - Mid Rise	6.30	6.30	5.34	3.40	3.77
		Religious Building	6.37	5.97	5.72	4.19	4.79
		Restaurant	5.37	5.38	4.83	3.66	4.33
		Retail - Department Store	5.53	5.08	4.77	3.10	3.54
		Retail - Strip Mall	5.29	4.90	4.33	2.98	3.22
		Warehouse	5.78	5.39	5.56	3.47	4.28
		Unknown	6.17	6.11	5.44	3.90	4.52
	Hot Water with outdoor reset	All buildings, Recirculation heating season only (Hours below 55F)	15.82	15.58	14.11	12.62	13.03
	Hot Water without outdoor reset	All buildings, Recirculation heating season only (Hours below 55F)	20.02	19.71	17.86	15.97	16.49
	Hot Water with outdoor reset	All buildings, Recirculation year round (All hours)	23.16	23.16	23.16	23.16	23.16
	Hot Water without outdoor reset	All buildings, Recirculation year round (All hours)	34.79	34.79	34.79	34.79	34.79
	LP Steam – non-recirculation	Assembly	11.11	11.38	10.16	6.77	10.37
		Assisted Living	10.46	10.23	8.99	6.61	7.94
		College	9.51	8.89	7.93	4.40	5.28
		Convenience Store	9.21	8.50	7.55	5.42	6.05
		Elementary School	11.07	10.79	9.52	6.57	7.98
		Garage	6.12	6.02	5.29	4.23	4.68
		Grocery	10.00	9.96	8.73	5.45	6.50
		Healthcare Clinic	9.81	10.07	8.79	5.99	6.33
		High School	11.47	11.54	10.35	7.38	8.63
		Hospital - CAV no econ	10.97	11.30	9.63	8.28	9.40
		Hospital - CAV econ	11.11	11.52	9.82	8.51	9.66
		Hospital - VAV econ	4.54	4.32	3.25	1.95	2.11
		Hospital - FCU	8.24	9.41	7.66	9.00	12.10
		Hotel/Motel	10.95	10.64	9.60	6.56	8.02
		Hotel/Motel - Common	9.95	10.11	9.62	7.83	8.23

			Annual therm Savings per linear foot (therm /ft) (2" pipe / 1" insulation for hot water, 2" insulation for steam)				
Location	System Type	Building Type	Zone 1 (Rockford)	Zone 2 (Chicago)	Zone 3 (Springfield)	Zone 4 (Belleville)	Zone 5 (Marion)
		Hotel/Motel - Guest	10.93	10.57	9.46	6.33	7.78
		Manufacturing Facility	6.51	6.30	5.84	3.53	3.94
		MF - High Rise	11.82	11.66	10.63	9.05	9.07
		MF - High Rise - Common	14.05	13.65	12.23	8.43	10.89
		MF - High Rise - Residential	11.42	11.33	10.30	8.92	8.70
		MF - Mid Rise	12.90	13.05	11.23	8.26	9.41
		Movie Theater	11.30	11.14	10.41	7.91	9.42
		Office - High Rise - CAV no econ	12.56	12.74	11.62	7.78	8.47
		Office - High Rise - CAV econ	12.99	13.25	12.19	8.40	9.24
		Office - High Rise - VAV econ	9.49	9.69	7.98	4.71	5.26
		Office - High Rise - FCU	6.96	6.85	5.92	3.15	3.29
		Office - Low Rise	8.88	8.86	7.04	4.31	4.93
		Office - Mid Rise	9.86	9.86	8.35	5.31	5.91
		Religious Building	9.97	9.35	8.95	6.56	7.50
		Restaurant	8.39	8.42	7.56	5.72	6.78
		Retail - Department Store	8.65	7.95	7.46	4.85	5.54
		Retail - Strip Mall	8.28	7.67	6.77	4.67	5.03
		Warehouse	9.05	8.44	8.71	5.44	6.70
		Unknown	9.66	9.57	8.51	6.11	7.08
	LP Steam	All buildings, Recirculation heating season only (Hours below 55F)	31.32	30.85	27.94	25.00	25.80
	LP Steam	All buildings, Recirculation year round (All hours)	54.46	54.46	54.46	54.46	54.46
	HP Steam – non-recirculation	Assembly	17.20	17.62	15.73	10.48	16.06
		Assisted Living	16.20	15.84	13.91	10.23	12.29
		College	14.73	13.76	12.28	6.82	8.17
		Convenience Store	14.25	13.16	11.68	8.38	9.36
		Elementary School	17.14	16.70	14.73	10.18	12.35
		Garage	9.47	9.32	8.20	6.54	7.24
		Grocery	15.47	15.41	13.51	8.43	10.07
		Healthcare Clinic	15.19	15.59	13.61	9.27	9.81
		High School	17.75	17.87	16.03	11.42	13.36
		Hospital - CAV no econ	16.98	17.49	14.90	12.82	14.55
		Hospital - CAV econ	17.21	17.83	15.20	13.17	14.96
		Hospital - VAV econ	7.04	6.68	5.02	3.02	3.27
		Hospital - FCU	12.76	14.56	11.85	13.93	18.73
		Hotel/Motel	16.95	16.48	14.86	10.17	12.41
		Hotel/Motel - Common	15.40	15.65	14.90	12.12	12.74
		Hotel/Motel - Guest	16.92	16.38	14.64	9.80	12.05
		Manufacturing Facility	10.09	9.75	9.04	5.46	6.10
		MF - High Rise	14.69	14.50	13.22	11.25	11.28
		MF - High Rise - Common	17.46	16.96	15.21	10.48	13.53
		MF - High Rise - Residential	14.19	14.08	12.80	11.09	10.81
		MF - Mid Rise	16.04	16.22	13.96	10.26	11.70
		Movie Theater	17.49	17.23	16.12	12.25	14.59
		Office - High Rise - CAV no econ	19.44	19.73	17.98	12.05	13.12
	Office - High Rise - CAV econ	20.10	20.51	18.86	13.00	14.30	



Location	System Type	Building Type	Annual therm Savings per linear foot (therm /ft) (2" pipe / 1" insulation for hot water, 2" insulation for steam)				
			Zone 1 (Rockford)	Zone 2 (Chicago)	Zone 3 (Springfield)	Zone 4 (Belleville)	Zone 5 (Marion)
		Office - High Rise - VAV econ	14.70	14.99	12.36	7.30	8.14
		Office - High Rise - FCU	10.76	10.60	9.16	4.86	5.10
		Office - Low Rise	13.75	13.71	10.89	6.66	7.63
		Office - Mid Rise	15.25	15.27	12.92	8.23	9.15
		Religious Building	15.43	14.47	13.85	10.15	11.60
		Restaurant	12.99	13.03	11.70	8.85	10.49
		Retail - Department Store	13.39	12.31	11.55	7.52	8.57
		Retail - Strip Mall	12.82	11.87	10.49	7.23	7.79
		Warehouse	14.01	13.06	13.48	8.41	10.37
		Unknown	14.95	14.81	13.17	9.45	10.96
		HP Steam	All buildings, Recirculation heating season only (Hours below 55F)	48.49	47.76	43.25	38.69
HP Steam	All buildings, Recirculation year round (All hours)	84.30	84.30	84.30	84.30	84.30	

For insulation covering elbows and tees that connect straight pipe, a calculated surface area will be assumed based on the dimensions for fittings given by ANSI/ASME B36.19. The surface area is then converted to an equivalent length of pipe that must be added to the total length of straight pipe in order to calculate total savings. Equivalent pipe lengths are given in 1" increments in pipe diameter for simplicity. In the case of pipe diameters in between full inch diameters, the closest equivalent length should be used. The larger pipe sizes mostly apply to steam header piping, which has the most heat loss per foot.

#### Calculated Surface Areas of Elbows and Tees

Nominal Pipe Diameter	Calculated Surface Area (ft)	
	90 Degree Elbow <sup>708</sup>	Straight Tee <sup>709</sup>
1"	0.10	0.13
2"	0.41	0.39
3"	0.93	0.77
4"	1.64	1.21
5"	2.57	1.77
6"	3.70	2.44
8"	6.58	3.95
10"	10.28	5.98
12"	14.80	8.34

#### Equivalent Length of Other Components – Elbows and Tees (L<sub>oc</sub>)

Nominal Pipe Diameter	Equivalent Length of Other Components (ft)	
	90 Degree Elbow	Straight Tee
1"	0.30	0.38
2"	0.66	0.63
3"	1.01	0.84
4"	1.40	1.03

<sup>708</sup> Based on the dimensions for diameter, long radius, and short radius given by ANSI/ASME 36.19.

<sup>709</sup> Based on the center to face and diameter dimensions given by ANSI/ASME B36.19.

Nominal Pipe Diameter	Equivalent Length of Other Components (ft)	
	90 Degree Elbow	Straight Tee
5"	1.76	1.22
6"	2.13	1.41
8"	2.91	1.75
10"	3.65	2.13
12"	4.44	2.50

For insulation around valves or flanges, a surface area from ASTM standard C1129-12 will be assumed for 2" pipes. For 1" pipes, which weren't included in the standard, a linear-trended value will be used. The surface area is then converted to an equivalent length of either 1" or 2" straight pipe that must be added to the total length of straight pipe in order to calculate total savings.

**Calculated Surface Areas of Flanges and Valves**

Valves				
Class (psi)	150	300	600	900
NPS (in)	ft <sup>2</sup>	ft <sup>2</sup>	ft <sup>2</sup>	ft <sup>2</sup>
1	0.69	1.8	1.8	2.4
2	2.21	2.94	2.94	5.2
2.5	2.97	3.51	3.91	6.6
3	3.37	4.39	4.69	6.5
4	4.68	6.06	7.64	9.37
6	7.03	9.71	13.03	15.8
8	10.3	13.5	18.4	23.8
10	13.8	18	26.5	32.1
12	16.1	24.1	31.9	41.9

Flanges				
Class (psi)	150	300	600	900
NPS (in)	ft <sup>2</sup>	ft <sup>2</sup>	ft <sup>2</sup>	ft <sup>2</sup>
1	0.36	0.36	0.4	1.23
2	0.71	0.84	0.88	1.54
3	1.06	1.32	1.36	1.85
4	1.44	1.83	2.23	2.64
6	2.04	2.72	3.6	4.37
8	2.92	3.74	4.89	6.4
10	3.68	4.8	6.93	8.47
12	5.01	6.34	7.97	10.43

**Equivalent Length of Other Components - Flanges and Valves (L<sub>oc</sub>)**

ANSI Class (psi)	Equivalent Length of Other Components (ft)			
	1" Valve	1" Flange	2" Valve	2" Flange
150	2.00	1.04	3.56	1.14
300	5.22	1.04	4.73	1.35
600	5.22	1.16	4.73	1.42
900	6.96	3.57	8.37	2.48
ANSI Class (psi)	3" Valve	3" Flange	4" Valve	4" Flange
150	3.67	1.16	3.98	1.22
300	4.79	1.44	5.15	1.56
600	5.11	1.48	6.49	1.90
900	7.09	2.02	7.96	2.24

**WATER IMPACT DESCRIPTIONS AND CALCULATION**

N/A

**DEEMED O&M COST ADJUSTMENT CALCULATION**

N/A

**MEASURE CODE: CI-HVC-PINS-V08-230101**

**REVIEW DEADLINE: 1/1/2024**

## 4.4.15 Single-Package and Split System Unitary Air Conditioners

### DESCRIPTION

This measure promotes the installation of high-efficiency unitary air-, water-, and evaporatively-cooled air conditioning equipment, both single-package and split systems. Air conditioning (AC) systems are a major consumer of electricity and systems that exceed baseline efficiency requirements can significantly reduce energy consumption. This measure could apply to the replacing of an existing unit at the end of its useful life or the installation of a new unit in a new or existing building.

This measure was developed to be applicable to the following program types: TOS, NC, EREP. If applied to other program types, the measure savings should be verified.

### DEFINITION OF EFFICIENT EQUIPMENT

The efficient equipment is assumed to be a high-efficiency air-, water-, or evaporatively-cooled air conditioner that exceeds the energy efficiency requirements as prescribed by the program.

### DEFINITION OF BASELINE EQUIPMENT

In order for this characterization to apply, the baseline equipment is assumed to be a standard-efficiency air-, water-, or evaporatively-cooled air conditioner that meets the Code energy efficiency requirements (IECC or Code of Federal Regulations whichever is higher) in effect on the date of equipment purchase (if date is unknown, assume current Code minimum).

For Early Replacement programs, use the actual efficiency of the existing unit or assume IECC code base in place at the original time of existing unit installation. To qualify under the early replacement characterization, baseline equipment must meet these additional qualifications:

- The existing unit is operational when replaced or the existing unit would be operational with minor repairs.<sup>710</sup>

In order for this characterization to apply, the baseline equipment is assumed to meet the efficiency requirements within the IECC code in effect on the date of the building permit. As code requirements and adoption can differ from municipality to municipality, the user should verify which version of code is applicable given these constraints.

Note, IECC 2021 is expected to become effective statewide in 2023. IECC 2018 is the requisite code for any projects with permitting dates spanning July 1, 2019 to the IECC 2021 effective date. Prior to July 1, 2019, IECC 2015 is the applicable code. If evaluation determines the applicable version of code, given location and timing, isn't an appropriate baseline due to supply constraints, low compliance, or other issues, the previous iteration of code may be used through 2023.

IECC 2021 leverages new DOE testing methods and associated metrics. The following conversion factors are recommended for use if the efficient equipment is not rated under the new testing procedure but the stipulated baseline is:<sup>711</sup>

$$\text{SEER2} = X * \text{SEER}$$

$$\text{EER2} = X * \text{EER}$$

$$\text{HSPF2} = X * \text{HSPF}$$

<sup>710</sup> Based on ComEd Small Business Trade Ally feedback. For units rated at less than 20 ton units, the cost of common repairs is under \$2,000, significantly less than the cost of purchasing new equipment. Therefore, if the cost of repair is less than \$2,000, it can be considered early replacement because customers would repair instead of replace a failed unit. Repair cost data was not available for units larger than 20 tons.

<sup>711</sup> Consortium for Energy Efficiency (CEE), Testing, Testing, M1, 2, 3, Transitioning to New Federal Minimum Standards, CEE Summer Program Meeting, August, 2022.

Where:

X	SEER2	EER2	HSPF2
Ducted	0.95	0.95	0.85
Ductless	1.00	1.00	0.90
Packaged	0.95	0.95	0.84

Note: new Federal Standards affecting heat pumps and air conditioning equipment became effective January 1, 2023.

**DEEMED LIFETIME OF EFFICIENT EQUIPMENT**

The expected measure life is assumed to be 15 years.<sup>712</sup>

For early replacement, the remaining life of existing equipment is assumed to be 5 years.<sup>713</sup>

**DEEMED MEASURE COST**

The incremental capital cost for this measure is based upon capacity and efficiency level (defined by CEE specifications),<sup>714</sup> as outlined in the following table:<sup>715</sup>

Capacity	Incremental cost (\$/ton)	
	Up to and including CEE Tier 1 units	CEE Tier 2 and above
< 135,000 Btu/hr	\$63	\$127
135,000 Btu/hr to > 250,000 Btu/hr	\$63	\$127
250,000 Btu/hr and greater	\$19	\$38

For early replacement, the full cost of the installed unit should be used. If unknown use defaults below. The assumed deferred cost (after 5 years) of replacing existing equipment with a new baseline unit is also provided. This future cost should be discounted to present value using the real discount rate:

Capacity	Full Install Cost (\$/ton)		
	Base Units	Up to and including CEE Tier 1 units	CEE Tier 2 and above
< 135,000 Btu/hr	\$895	\$958	\$1,021
135,000 Btu/hr to > 250,000 Btu/hr	\$762	\$825	\$889
250,000 Btu/hr and greater	\$673	\$691	\$710

**LOADSHAPE**

Loadshape C03 - Commercial Cooling

**COINCIDENCE FACTOR**

The summer peak coincidence factor for cooling is provided in two different ways below. The first is used to estimate peak savings during the utility peak hour and is most indicative of actual peak benefits, and the second represents the *average* savings over the defined summer peak period and is presented so that savings can be bid into PJM’s

<sup>712</sup> Measure Life Report: Residential and Commercial/Industrial Lighting and HVAC Measures, GDS Associates, Inc., June 2007.

<sup>713</sup> Assumed to be one third of effective useful life.

<sup>714</sup> CEE Commercial Unitary Air-conditioning and Heat Pumps Specification, which provides high efficiency performance specifications for single-package and split system unitary air conditioners.

<sup>715</sup> NEEP Incremental Cost Study (ICS) Final Report – Phase 3, May 2014.

capacity market. Both values provided are based on analysis of Itron eShape data for Missouri, calibrated to Illinois loads, supplied by Ameren.

$$\begin{aligned} CF_{SSP} &= \text{Summer System Peak Coincidence Factor for Commercial cooling (during system peak hour)} \\ &= 91.3\% \text{ }^{716} \end{aligned}$$

$$\begin{aligned} CF_{PJM} &= \text{PJM Summer Peak Coincidence Factor for Commercial cooling (average during peak period)} \\ &= 47.8\% \text{ }^{717} \end{aligned}$$

---



---

### Algorithm

---

#### CALCULATION OF SAVINGS

##### ELECTRIC ENERGY SAVINGS

Time of Sale:

For units with cooling capacities less than 65 kBtu/hr:

$$\Delta kWH = (kBtu/hr) * [(1/SEER_{base}) - (1/SEER_{ee})] * EFLH$$

For units with cooling capacities equal to or greater than 65 kBtu/hr:

$$\Delta kWH = (kBtu/hr) * [(1/IEER_{base}) - (1/IEER_{ee})] * EFLH$$

Early replacement:<sup>718</sup>

For units with cooling capacities less than 65 kBtu/hr:

For remaining life of existing unit (1st 5 years):

$$\Delta kWH = (kBtu/hr) * [(1/SEER_{exist}) - (1/SEER_{ee})] * EFLH$$

For remaining measure life (next 10 years):

$$\Delta kWH = (kBtu/hr) * [(1/SEER_{base}) - (1/SEER_{ee})] * EFLH$$

For units with cooling capacities equal to or greater than 65 kBtu/hr:

For remaining life of existing unit (1st 5 years):

$$\Delta kWH = (kBtu/hr) * [(1/IEER_{exist}) - (1/IEER_{ee})] * EFLH$$

NOTE: If the existing equipment age is such that IEER ratings are not available, EER may be substituted when necessary. In such instances both existing and efficient unit efficiencies should be specified in EER.

For remaining measure life (next 10 years):

$$\Delta kWH = (kBtu/hr) * [(1/IEER_{base}) - (1/IEER_{ee})] * EFLH$$

Where:

---

<sup>716</sup> Based on analysis of Itron eShape data for Missouri, calibrated to Illinois loads, supplied by Ameren. The AC load during the utility's peak hour is divided by the maximum AC load during the year.

<sup>717</sup> Based on analysis of Itron eShape data for Missouri, calibrated to Illinois loads, supplied by Ameren. The average AC load over the PJM peak period (1-5pm, M-F, June through August) is divided by the maximum AC load during the year.

<sup>718</sup> The two equations are provided to show how savings are determined during the initial phase of the measure (existing to efficient) and the remaining phase (new baseline to efficient). In practice, the screening tools used may either require a First Year savings (using the first equation) and then a "number of years to adjustment" and "savings adjustment" input which would be the (new base to efficient savings)/(existing to efficient savings).

kBtu/hr	= capacity of the cooling equipment actually installed in kBtu per hour (1 ton of cooling capacity equals 12 kBtu/hr)
SEER <sub>base</sub>	= Seasonal Energy Efficiency Ratio of the baseline equipment = SEER values from tables below, based on applicable Code on date of equipment purchase (if unknown assume current Code).
SEER <sub>ee</sub>	= Seasonal Energy Efficiency Ratio of the energy efficient equipment (actually installed)
SEER <sub>exist</sub>	= Seasonal Energy Efficiency Ratio of the existing equipment = Actual, or assume Code base in place at the original time of existing unit installation
IEER <sub>base</sub>	= Integrated Energy Efficiency Ratio of the baseline equipment. See table below based on applicable Code on date of equipment purchase (if unknown assume current Code).
IEER <sub>ee</sub>	= Integrated Energy Efficiency Ratio of the energy efficient equipment (actually installed)
IEER <sub>exist</sub>	= Integrated Energy Efficiency Ratio of the existing equipment = Actual, or assume Code base in place at the original time of existing unit installation
EFLH	= Equivalent Full Load Hours for cooling in Existing Buildings or New Construction are provided in section 4.4 HVAC End Use

The rating conditions for the baseline and efficient equipment efficiencies must be equivalent.

**Code of Federal Redulations (baseline effective 1/1/2023):<sup>719</sup>**

Equipment type	Cooling capacity	Heating type	Efficiency level	Compliance date
Small Commercial Packaged Air Conditioning and Heating Equipment (Air-Cooled)	≥65,000 Btu/h and <135,000 Btu/h	Electric Resistance Heating or No Heating	IEER = 12.9 IEER = 14.8	1/1/2018 1/1/2023
		All Other Types of Heating	IEER = 12.7 IEER = 14.6	1/1/2018 1/1/2023
Large Commercial Packaged Air Conditioning and Heating Equipment (Air-Cooled)	≥135,000 Btu/h and <240,000 Btu/h	Electric Resistance Heating or No Heating	IEER = 12.4 IEER = 14.2	1/1/2018 1/1/2023
		All Other Types of Heating	IEER = 12.2 IEER = 14.0	1/1/2018 1/1/2023
Very Large Commercial Packaged Air Conditioning and Heating Equipment (Air-Cooled)	≥240,000 Btu/h and <760,000 Btu/h	Electric Resistance Heating or No Heating	IEER = 11.6 IEER = 13.2	1/1/2018 1/1/2023
		All Other Types of Heating	IEER = 11.4 IEER = 13.0	1/1/2018 1/1/2023
Small Commercial Package Air-Conditioning and Heating Equipment (Air-Cooled, 3-Phase, Split-System)	<65,000 Btu/h	All	SEER2 = 14.3	1/1/2023
Small Commercial Package Air-Conditioning and Heating Equipment (Air-Cooled, 3-Phase, Single-Package)	<65,000Btu/h	All	SEER2 = 13.4	1/1/2023

<sup>719</sup> Code of Federal Regulations: Table 3 to §431.97 – Updates to Minimum Cooling Efficiency Standards for Air Conditioning and Heating Equipment



2015 IECC Minimum Efficiency Requirements (baseline effective 1/1/2016 to 6/30/2019)

**TABLE C403.2.3(1)**  
**MINIMUM EFFICIENCY REQUIREMENTS:**  
**ELECTRICALLY OPERATED UNITARY AIR CONDITIONERS AND CONDENSING UNITS**

EQUIPMENT TYPE	SIZE CATEGORY	HEATING SECTION TYPE	SUBCATEGORY OR RATING CONDITION	MINIMUM EFFICIENCY		TEST PROCEDURE <sup>2</sup>	
				Before 1/1/2016	As of 1/1/2016		
Air conditioners, air cooled	< 65,000 Btu/h <sup>3</sup>	All	Split System	13.0 SEER	13.0 SEER	AHRI 210/240	
			Single Package	13.0 SEER	14.0 SEER <sup>4</sup>		
Through-the-wall (air cooled)	≤ 30,000 Btu/h <sup>3</sup>	All	Split system	12.0 SEER	12.0 SEER		
			Single Package	12.0 SEER	12.0 SEER		
Small-duct high-velocity (air cooled)	< 65,000 Btu/h <sup>3</sup>	All	Split System	11.0 SEER	11.0 SEER		
Air conditioners, air cooled	≥ 65,000 Btu/h and < 135,000 Btu/h	Electric Resistance (or None)	Split System and Single Package	11.2 EER	11.2 EER		AHRI 340/360
			11.4 IEER	12.8 IEER			
	All other	Split System and Single Package	11.0 EER	11.0 EER			
		11.2 IEER	12.6 IEER				
	≥ 135,000 Btu/h and < 240,000 Btu/h	Electric Resistance (or None)	Split System and Single Package	11.0 EER	11.0 EER		
			11.2 IEER	12.4 IEER			
	All other	Split System and Single Package	10.8 EER	10.8 EER			
		11.0 IEER	12.2 IEER				
	≥ 240,000 Btu/h and < 760,000 Btu/h	Electric Resistance (or None)	Split System and Single Package	10.0 EER	10.0 EER		
			10.1 IEER	11.6 IEER			
	All other	Split System and Single Package	9.8 EER	9.8 EER			
		9.9 IEER	11.4 IEER				
≥ 760,000 Btu/h	Electric Resistance (or None)	Split System and Single Package	9.7 EER	9.7 EER			
		9.8 IEER	11.2 IEER				
All other	Split System and Single Package	9.5 EER	9.5 EER				
	9.6 IEER	11.0 IEER					
Air conditioners, water cooled	< 65,000 Btu/h <sup>3</sup>	All	Split System and Single Package	12.1 EER	12.1 EER	AHRI 210/240	
			12.3 IEER	12.3 IEER			
	≥ 65,000 Btu/h and < 135,000 Btu/h	Electric Resistance (or None)	Split System and Single Package	12.1 EER	12.1 EER		AHRI 340/360
			12.3 IEER	13.9 IEER			
	All other	Split System and Single Package	11.9 EER	11.9 EER			
		12.1 IEER	13.7 IEER				
	≥ 135,000 Btu/h and < 240,000 Btu/h	Electric Resistance (or None)	Split System and Single Package	12.5 EER	12.5 EER		
			12.5 IEER	13.9 IEER			
	All other	Split System and Single Package	12.3 EER	12.3 EER			
		12.5 IEER	13.7 IEER				
	≥ 240,000 Btu/h and < 760,000 Btu/h	Electric Resistance (or None)	Split System and Single Package	12.4 EER	12.4 EER		
			12.6 IEER	13.6 IEER			
All other	Split System and Single Package	12.2 EER	12.2 EER				
	12.4 IEER	13.4 IEER					
≥ 760,000 Btu/h	Electric Resistance (or None)	Split System and Single Package	12.2 EER	12.2 EER			
		12.4 IEER	13.5 IEER				
All other	Split System and Single Package	12.0 EER	12.0 EER				
	12.2 IEER	13.3 IEER					

(continued)

2018 IECC Minimum Efficiency Requirements (baseline effective 7/1/2019 to 9/30/2022)

TABLE C403.3.2(1)  
MINIMUM EFFICIENCY REQUIREMENTS: ELECTRICALLY OPERATED UNITARY AIR CONDITIONERS AND CONDENSING UNITS

EQUIPMENT TYPE	SIZE CATEGORY	HEATING SECTION TYPE	SUBCATEGORY OR RATING CONDITION	MINIMUM EFFICIENCY	TEST PROCEDURE <sup>a</sup>
Air conditioners, air cooled	< 65,000 Btu/h <sup>b</sup>	All	Split System	13.0 SEER	AHRI 210/240
			Single Package	14.0 SEER	
Through-the-wall (air cooled)	≤ 30,000 Btu/h <sup>b</sup>	All	Split system	12.0 SEER	
			Single Package	12.0 SEER	
Small-duct high-velocity (air cooled)	< 65,000 Btu/h <sup>b</sup>	All	Split System	11.0 SEER	
Air conditioners, air cooled	≥ 65,000 Btu/h and < 135,000 Btu/h	Electric Resistance (or None)	Split System and Single Package	11.2 EER 12.8 IEER	AHRI 340/360
		All other	Split System and Single Package	11.0 EER 12.6 IEER	
	≥ 135,000 Btu/h and < 240,000 Btu/h	Electric Resistance (or None)	Split System and Single Package	11.0 EER 12.4 IEER	
		All other	Split System and Single Package	10.8 EER 12.2 IEER	
	≥ 240,000 Btu/h and < 760,000 Btu/h	Electric Resistance (or None)	Split System and Single Package	10.0 EER 11.6 IEER	
		All other	Split System and Single Package	9.8 EER 11.4 IEER	
	≥ 760,000 Btu/h	Electric Resistance (or None)	Split System and Single Package	9.7 EER 11.2 IEER	
		All other	Split System and Single Package	9.5 EER 11.0 IEER	
Air conditioners, water cooled	< 65,000 Btu/h <sup>b</sup>	All	Split System and Single Package	12.1 EER 12.3 IEER	AHRI 210/240
			≥ 65,000 Btu/h and < 135,000 Btu/h	Electric Resistance (or None)	Split System and Single Package
	All other	Split System and Single Package		11.9 EER 13.7 IEER	
	≥ 135,000 Btu/h and < 240,000 Btu/h	Electric Resistance (or None)	Split System and Single Package	12.5 EER 13.9 IEER	
		All other	Split System and Single Package	12.3 EER 13.7 IEER	
	≥ 240,000 Btu/h and < 760,000 Btu/h	Electric Resistance (or None)	Split System and Single Package	12.4 EER 13.6 IEER	
		All other	Split System and Single Package	12.2 EER 13.4 IEER	
	≥ 760,000 Btu/h	Electric Resistance (or None)	Split System and Single Package	12.2 EER 13.5 IEER	
		All other	Split System and Single Package	12.0 EER 13.3 IEER	

Air conditioners, evaporatively cooled	< 65,000 Btu/h <sup>b</sup>	All	Split System and Single Package	12.1 EER 12.3 IEER	AHRI 210/240
	≥ 65,000 Btu/h and < 135,000 Btu/h	Electric Resistance (or None)	Split System and Single Package	12.1 EER 12.3 IEER	AHRI 340/360
		All other	Split System and Single Package	11.9 EER 12.1 IEER	
	≥ 135,000 Btu/h and < 240,000 Btu/h	Electric Resistance (or None)	Split System and Single Package	12.0 EER 12.2 IEER	
		All other	Split System and Single Package	11.8 EER 12.0 IEER	
	≥ 240,000 Btu/h and < 760,000 Btu/h	Electric Resistance (or None)	Split System and Single Package	11.9 EER 12.1 IEER	
		All other	Split System and Single Package	11.7 EER 11.9 IEER	
	≥ 760,000 Btu/h	Electric Resistance (or None)	Split System and Single Package	11.7 EER 11.9 IEER	
All other		Split System and Single Package	11.5 EER 11.7 IEER		
Condensing units, air cooled	≥ 135,000 Btu/h	—	—	10.5 EER 11.8 IEER	AHRI 365
Condensing units, water cooled	≥ 135,000 Btu/h	—	—	13.5 EER 14.0 IEER	
Condensing units, evaporatively cooled	≥ 135,000 Btu/h	—	—	13.5 EER 14.0 IEER	

For SI: 1 British thermal unit per hour = 0.2931 W.

- a. Chapter 6 contains a complete specification of the referenced test procedure, including the reference year version of the test procedure.
- b. Single-phase, air-cooled air conditioners less than 65,000 Btu/h are regulated by NAECA. SEER values are those set by NAECA.

2021 IECC Minimum Efficiency Requirements (baseline effective 10/1/2022)

**TABLE C403.3.2(1)  
ELECTRICALLY OPERATED UNITARY AIR CONDITIONERS AND CONDENSING UNITS—MINIMUM EFFICIENCY REQUIREMENTS<sup>c, d</sup>**

EQUIPMENT TYPE	SIZE CATEGORY	HEADING SECTION TYPE	SUBCATEGORY OR RATING CONDITION	MINIMUM EFFICIENCY	TEST PROCEDURE <sup>e</sup>
Air conditioners, air cooled	< 65,000 Btu/h <sup>b</sup>	All	Split system, three phase and applications outside US single phase <sup>b</sup>	13.0 SEER before 1/1/2023 13.4 SEER2 after 1/1/2023	AHRI 210/240—2017 before 1/1/2023 AHRI 210/240—2023 after 1/1/2023
			Single-package, three phase and applications outside US single phase <sup>b</sup>	14.0 SEER before 1/1/2023 13.4 SEER2 after 1/1/2023	
Space constrained, air cooled	≤ 30,000 Btu/h <sup>b</sup>	All	Split system, three phase and applications outside US single phase <sup>b</sup>	12.0 SEER before 1/1/2023 11.7 SEER2 after 1/1/2023	AHRI 210/240—2017 before 1/1/2023 AHRI 210/240—2023 after 1/1/2023
			Single package, three phase and applications outside US single phase <sup>b</sup>	12.0 SEER before 1/1/2023 11.7 SEER2 after 1/1/2023	
Small duct, high velocity, air cooled	< 65,000 Btu/h <sup>b</sup>	All	Split system, three phase and applications outside US single phase <sup>b</sup>	12.0 SEER before 1/1/2023 12.1 SEER2 after 1/1/2023	AHRI 210/240—2017 before 1/1/2023 AHRI 210/240—2023 after 1/1/2023
Air conditioners, air cooled	≥ 65,000 Btu/h and < 135,000 Btu/h	Electric resistance (or none)	Split system and single package	11.2 EER 12.9 IEER before 1/1/2023 14.8 IEER after 1/1/2023	AHRI 340/360
		All other		11.0 EER 12.7 IEER before 1/1/2023 14.6 IEER after 1/1/2023	
	Electric resistance (or none)	11.0 EER 12.4 IEER before 1/1/2023 14.2 IEER after 1/1/2023			
	All other	10.8 EER 12.2 IEER before 1/1/2023 14.0 IEER after 1/1/2023			
	≥ 135,000 Btu/h and < 240,000 Btu/h				

**TABLE C403.3.2(1)—continued  
ELECTRICALLY OPERATED UNITARY AIR CONDITIONERS AND CONDENSING UNITS—MINIMUM EFFICIENCY REQUIREMENTS<sup>c, d</sup>**

EQUIPMENT TYPE	SIZE CATEGORY	HEADING SECTION TYPE	SUBCATEGORY OR RATING CONDITION	MINIMUM EFFICIENCY	TEST PROCEDURE <sup>e</sup>			
Air conditioners, air cooled <i>(continued)</i>	≥ 240,000 Btu/h and < 760,000 Btu/h	Electric resistance (or none)	Split system and single package	10.0 EER 11.6 IEER before 1/1/2023 13.2 IEER after 1/1/2023	AHRI 340/360			
		All other		9.8 EER 11.4 IEER before 1/1/2023 13.0 IEER after 1/1/2023				
	≥ 760,000 Btu/h	Electric resistance (or none)		9.7 EER 11.2 IEER before 1/1/2023 12.5 IEER after 1/1/2023				
		All other		9.5 EER 11.0 IEER before 1/1/2023 12.3 IEER after 1/1/2023				
		Air conditioners, water cooled		< 65,000 Btu/h		All	12.1 EER 12.3 IEER	AHRI 210/240
						≥ 65,000 Btu/h and < 135,000 Btu/h	Electric resistance (or none)	12.1 EER 13.9 IEER
All other	11.9 EER 13.7 IEER							
≥ 135,000 Btu/h and < 240,000 Btu/h	Electric resistance (or none)		12.5 EER 13.9 IEER					
	All other		12.3 EER 13.7 IEER					
≥ 240,000 Btu/h and < 760,000 Btu/h	Electric resistance (or none)		12.4 EER 13.6 IEER					
	All other	12.2 EER 13.4 IEER						
≥ 760,000 Btu/h	Electric resistance (or none)	12.2 EER 13.5 IEER						
	All other	12.0 EER 13.3 IEER						

**TABLE C403.3.2(1)—continued**  
**ELECTRICALLY OPERATED UNITARY AIR CONDITIONERS AND CONDENSING UNITS—MINIMUM EFFICIENCY REQUIREMENTS<sup>c, d</sup>**

EQUIPMENT TYPE	SIZE CATEGORY	HEADING SECTION TYPE	SUBCATEGORY OR RATING CONDITION	MINIMUM EFFICIENCY	TEST PROCEDURE <sup>a</sup>
Air conditioners, evaporatively cooled	< 65,000 Btu/h <sup>b</sup>	All	Split system and single package	12.1 EER 12.3 IEER	AHRI 210/240
	≥ 65,000 Btu/h and < 135,000 Btu/h	Electric resistance (or none)		12.1 EER 12.3 IEER	AHRI 340/360
		All other		11.9 EER 12.1 IEER	
	≥ 135,000 Btu/h and < 240,000 Btu/h	Electric resistance (or none)		12.0 EER 12.2 IEER	
		All other		11.8 EER 12.0 IEER	
	≥ 240,000 Btu/h and < 760,000 Btu/h	Electric resistance (or none)		11.9 EER 12.1 IEER	
		All other		11.7 EER 11.9 IEER	
	≥ 760,000 Btu/h	Electric resistance (or none)		11.7 EER 11.9 IEER	
All other		11.5 EER 11.7 IEER			
Condensing units, air cooled	≥ 135,000 Btu/h	—	—	10.5 EER 11.8 IEER	AHRI 365
Condensing units, water cooled	≥ 135,000 Btu/h	—	—	13.5 EER 14.0 IEER	AHRI 365
Condensing units, evaporatively cooled	≥ 135,000 Btu/h	—	—	13.5 EER 14.0 IEER	AHRI 365

For SI: 1 British thermal unit per hour = 0.2931 W.

- a. Chapter 6 contains a complete specification of the referenced standards, which include test procedures, including the reference year version of the test procedure.
- b. Single-phase, US air-cooled air conditioners less than 65,000 Btu/h are regulated as consumer products by the US Department of Energy Code of Federal Regulations DOE 10 CFR 430. SEER and SEER2 values for single-phase products are set by the US Department of Energy.
- c. DOE 10 CFR 430 Subpart B Appendix M1 includes the test procedure updates effective 1/1/2023 that will be incorporated in AHRI 210/240—2023.
- d. This table is a replica of ASHRAE 90.1 Table 6.8.1-1 Electrically Operated Unitary Air Conditioners and Condensing Units—Minimum Efficiency Requirements.

**For example**, a 5 ton air cooled split system with a SEER of 15 at a retail strip mall in Rockford would save:

$$\begin{aligned}\Delta\text{kWh} &= (60) * [(1/13) - (1/15)] * 950 \\ &= 585 \text{ kWh}\end{aligned}$$

### SUMMER COINCIDENT PEAK DEMAND SAVINGS

Time of Sale:

$$\Delta\text{kW} = (\text{kBtu/hr} * (1/\text{EER}_{\text{base}} - 1/\text{EER}_{\text{ee}})) * \text{CF}$$

Early Replacement:

For remaining life of existing unit (1st 5 years):

$$\Delta\text{kW} = (\text{kBtu/hr}) * [(1/\text{EER}_{\text{exist}}) - (1/\text{EER}_{\text{ee}})] * \text{CF}$$

For remaining measure life (next 10 years):

$$\Delta\text{kW} = (\text{kBtu/hr}) * [(1/\text{EER}_{\text{base}}) - (1/\text{EER}_{\text{ee}})] * \text{CF}$$

Where:

$\text{EER}_{\text{base}}$	= Energy Efficiency Ratio of the baseline equipment = EER values from tables above, based on applicable Code on date of equipment purchase (if unknown assume current Code). (For air-cooled units < 65 kBtu/hr, assume the following conversion from SEER to EER for calculation of peak savings: <sup>720</sup> $\text{EER} = (-0.02 * \text{SEER}^2) + (1.12 * \text{SEER})$ )
$\text{EER}_{\text{ee}}$	= Energy Efficiency Ratio of the energy efficient equipment. If the actual $\text{EER}_{\text{ee}}$ is unknown, assume the conversion from SEER to EER for calculation of peak savings as above). = Actual installed
$\text{EER}_{\text{exist}}$	= Energy Efficiency Ratio of the existing equipment = Actual, or assume Code base in place at the original time of existing unit installation
$\text{CF}_{\text{SSP}}$	= Summer System Peak Coincidence Factor for Commercial cooling (during system peak hour) = 91.3% <sup>721</sup>
$\text{CF}_{\text{PJM}}$	= PJM Summer Peak Coincidence Factor for Commercial cooling (average during peak period) = 47.8% <sup>722</sup>

**For example**, a 5 ton air cooled split system with a SEER of 15 in Rockford would save:

$$\begin{aligned}\Delta\text{kW}_{\text{SSP}} &= (60) * [(1/11.2) - (1/12.3)] * .913 \\ &= 0.437 \text{ kW}\end{aligned}$$

<sup>720</sup> Based on Wassmer, M. (2003). A Component-Based Model for Residential Air Conditioner and Heat Pump Energy Calculations. Masters Thesis, University of Colorado at Boulder. Note this is appropriate for single speed units only.

<sup>721</sup> Based on analysis of Itron eShape data for Missouri, calibrated to Illinois loads, supplied by Ameren. The AC load during the utility's peak hour is divided by the maximum AC load during the year.

<sup>722</sup> Based on analysis of Itron eShape data for Missouri, calibrated to Illinois loads, supplied by Ameren. The average AC load over the PJM peak period (1-5pm, M-F, June through August) is divided by the maximum AC load during the year.

**FOSSIL FUEL SAVINGS**

N/A

**WATER IMPACT DESCRIPTIONS AND CALCULATION**

N/A

**MEASURE CODE: CI-HVC-SPUA-V10-240101**

**REVIEW DEADLINE: 1/1/2026**



## 4.4.16 Steam Trap Replacement or Repair

### DESCRIPTION

The measure applies to the repair or replacement of steam traps in the failed open state that allow steam to escape the steam distribution system or return to the condensate receiver leading to increased steam generation. The measure is applicable to commercial applications, commercial HVAC (low pressure steam) including multifamily buildings, low pressure industrial applications, medium pressure industrial applications, applications and high-pressure industrial applications.

This measure was developed to be applicable to the following program types: TOS, RF. If applied to other program types, the measure savings should be verified.

### DEFINITION OF EFFICIENT EQUIPMENT

Customers must have steam traps in the failed open or leaking state to qualify for rebates. However, if a commercial customer opts to replace all traps without inspection, rebates and the savings are discounted to take into consideration the fact that some traps are being replaced that have not yet failed.

### DEFINITION OF BASELINE EQUIPMENT

The baseline criterion is a faulty steam trap in the failed open or leaking state. No minimum leak rate is required. Any leaking or blow through trap can be repaired or replaced. If a commercial customer chooses to repair or replace all the steam traps at the facility without verification, the savings are adjusted. Savings for commercial full replacement projects are reduced by the percentage of traps found to be leaking on average from the studies listed. If an audit is performed on a commercial site, then the leaking and blowdown can be adjusted.

### DEEMED LIFETIME OF EFFICIENT EQUIPMENT

For standard steam traps the life of this measure is 6 years.<sup>723</sup>

For Venturi steam traps the measure life is 20 years if replacing a faulty mechanical steam trap.<sup>724</sup> If replacing an operational mechanical steam trap, the measure life is 14 years, having been reduced by the six-year measure life established for the Steam Trap Replacement or Repair measure from the IL TRM. By applying this conservative approach of reducing the measure life by the full estimated useful life of the existing steam trap, there is no need to survey or produce an inventory of the age of existing steam traps.

Venturi steam traps do not contain any moving parts, and their manufacturers cite this feature for the reduced failure rate leading to longer operational life than mechanical steam traps. Venturi steam traps have been observed to operate in excess of 20 years.<sup>725</sup> Venturi steam traps also typically come with a 10-year warranty that can be extended up to 20 years. Therefore, savings may be claimed on a year-to-year basis for venturi steam traps undergoing annual maintenance that have exhausted their deemed 20-year measure life.

---

<sup>723</sup>Source paper is the CLEAResult "Steam Traps Revision #1" dated August 2011. Primary studies used to prepare the source paper include Enbridge Steam Trap Survey, KW Engineering Steam Trap Survey, Enbridge Steam Saver Program 2005, Armstrong Steam Trap Survey, DOE Federal Energy Management Program Steam Trap Performance Assessment, Oak Ridge National Laboratory Steam System Survey Guide, KEMA Evaluation of PG&E's Steam Trap Program, Sept. 2007. Communication with vendors suggested an inverted bucket steam trap life typically in the range of 5 - 7 years, float and thermostatic traps 4- 6 years, float and thermodynamic disc traps of 1 - 3 years. Cost does not include installation.

<sup>724</sup> "Venturi Steam Trap – Functional Laboratory Study, GTI on behalf of Illinois utilities, Nicor Gas, Peoples Gas, and North Shore Gas, and on behalf of contributing utilities from other states, March 26, 2019. This report reflects phase 1 of an ongoing field study that will continue data collection to validate useful life and provide information on proper sizing in various end use applications. Additional data expected in 2021.

<sup>725</sup> Ibid. Based on reported age for venturi steam traps currently operating in the field.

**DEEMED MEASURE COST**

Actual measure costs, including survey and installation costs should be used where available. Default costs per trap are provided below to be used in addition to an estimate of survey and installation costs.

Steam System	Cost per trap <sup>726</sup> (\$)
Commercial Dry Cleaners	77
Commercial Heating (including Multifamily), low pressure steam	77
Industrial Medium Pressure: 15 < psig < 30	180
Steam Trap, Industrial Medium Pressure: 30 ≤ psig < 75	223
Steam Trap, Industrial High Pressure: 75 ≤ psig < 125	276
Steam Trap, Industrial High Pressure: 125 ≤ psig < 175	322
Steam Trap, Industrial High Pressure: 175 ≤ psig < 250	370
Steam Trap, Industrial High Pressure: 250 ≤ psig	418

**LOADSHAPE**

N/A

**COINCIDENCE FACTOR**

N/A

---

**Algorithm**

---

**CALCULATION OF SAVINGS**

**ENERGY SAVINGS**

**ELECTRIC ENERGY SAVINGS**

Secondary kWh Savings for Water Supply and Wastewater Treatment

The following savings should be included in the total savings for this measure but should not be included in TRC tests to avoid double counting the economic benefit of water savings. These savings only apply to situations in which steam is lost from the steam system.

$$\Delta kWh_{\text{water}} = \Delta \text{Water (gallons)} / 1,000,000 * E_{\text{water supply}}$$

Where

$$E_{\text{water supply}} = \text{Water Supply Energy Factor (kWh/Million Gallons)}$$

$$= 2,571^{727}$$

**SUMMER COINCIDENT PEAK DEMAND SAVINGS**

N/A

**FOSSIL FUEL SAVINGS**

$$\Delta \text{Therm} = Sa * (Hv + Hs * (T_1 - T_{\text{source}})) * \text{Hours} * L / (100,000 * \eta_B)$$

---

<sup>726</sup> Ibid.

<sup>727</sup> This factor include 2571 kWh/MG for water supply based on Illinois energy intensity data from a 2012 ISAWWA study. For more information please review Elevate Energy’s ‘IL TRM: Energy per Gallon Factor, May 2018 paper’. Note since the water loss associated with this measure is due to evaporation and does not discharge into the wastewater system, only the water supply factor is used here.

Where:

Sa = Steam loss per leaking trap (lbs/hr)

For systems used in space heating applications that operate at 5 psig or lower, use the following equation to calculate Sa<sup>728</sup>. The condensate return system pressure, P<sub>2</sub>, will typically be atmospheric pressure, 14.696 psia.

$$Sa = 1519.3 * P_1 * D^2 * [(1/T_1) * (\gamma/(\gamma-1)) * ((P_2/P_1)^{(2/\gamma)} - (P_2/P_1)^{((\gamma+1)/\gamma)})^{0.5} * A * FF$$

For all other steam systems and applications, use the following equation.

$$Sa = 24.24 * P_1 * D^2 * A * FF$$

Defaults are provided in table below if custom calculation is not performed.

Where:

1519.3 = Constant, (s<sup>2</sup> \* °R<sup>0.5</sup>)/(ft \* hr)

P<sub>1</sub> = Average steam trap inlet pressure (absolute, psia). If not available, use defaults provided in table below (note that defaults are provided in psig, not psia).

D = Diameter of orifice, inches. Actual value should be used wherever possible as this value has a significant impact on steam flowrate value.

T<sub>1</sub> = Temperature of Saturated Steam (°R)  
= 507.89 \* P<sub>1</sub><sup>0.0962</sup>

Where:

$$507.89 = \text{Constant, } ^\circ\text{R} * (\text{in}^2/\text{lb}_f)^{0.0962}$$

γ = Heat Capacity Ratio (unitless)  
= 5.071 \* 10<sup>-4</sup> \* P<sub>1</sub> + 1.332

P<sub>2</sub> = Average steam trap outlet pressure (absolute psia). If unknown, assume atmospheric pressure, 14.696 psia.

A = Adjustment factor  
= 50%,<sup>729</sup> all steam systems. This factor accounts for reduction in the maximum theoretical steam flow to the average steam flow (the Enbridge factor).

FF = Flow Factor. In addition to the Adjustment factor (A), an additional 50 percent flow factor adjustment is recommended for medium and high-pressure steam systems to address industrial float and thermostatic style traps where additional blockage is possible.

24.24 = Constant lbm/(hr-psia-in<sup>2</sup>)

<sup>728</sup> See "Derivation of Equation for Subsonic Compressible Flow through an Orifice and Supporting Calculations for Illinois TRM Steam Trap Measure" paper for more information.

<sup>729</sup>Enbridge adjustment factor used as referenced in CLEAResult "Work Paper Steam Traps Revision #2" Revision 3 dated March 2, 2012 and DOE Federal Energy Management Program Steam Trap Performance Assessment.

Default Steam Loss per Trap (Sa) are provided below for different system types:

Steam System	Average Steam Trap Inlet Pressure psig <sup>730</sup>	Diameter of Orifice in	Adjustment Factor	Flow Factor	Average Actual Steam Loss per Leaking Trap (lbm/hr/trap) <sup>731</sup>
Commercial Dry Cleaners	82.8	0.1250	50%	100%	18.5
Multifamily LPS Space Heating - calculate Sa as provided above. If using default value, cap total savings at 20% of building consumption	-	-	50%	100%	6.9
Commercial LPS Space Heating	11.2	0.2100	50%	100%	13.8
Industrial/Process Low Pressure: psig < 15	11.2	0.2100	50%	100%	13.8
Medium Pressure: 15 ≤ psig < 30	16	0.1875	50%	50%	6.5
Medium Pressure: 30 ≤ psig < 75	47	0.2500	50%	50%	23.4
High Pressure: 75 ≤ psig < 125	101	0.2500	50%	50%	43.8
High Pressure: 125 ≤ psig < 175	146	0.2500	50%	50%	60.9
High Pressure: 175 ≤ psig < 250	202	0.2500	50%	50%	82.1
High Pressure: 250 ≤ psig < 300	263	0.2500	50%	50%	105.2
High Pressure: 300 ≤ psig	Custom	Custom	50%	50%	Calculated

Hv = Heat of vaporization of steam, (Btu/lbm)

Steam System	Average Inlet Pressure psig	Heat of Vaporization <sup>732</sup> (Btu/lbm)
Commercial Dry Cleaners	82.8	890
Multifamily LPS Space Heating	--	951
Commercial Space Heating (including Multifamily) LPS	11.2	951
Industrial/Process Low Pressure: psig < 15	11.2	951
Medium Pressure: 15 ≤ psig < 30	16	944
Medium Pressure: 30 ≤ psig < 75	47	915
High Pressure: 75 ≤ psig < 125	101	880
High Pressure: 125 ≤ psig < 175	146	859
High Pressure: 175 ≤ psig < 250	202	837
High Pressure: 250 ≤ psig < 300	263	816
High Pressure: 300 ≤ psig	--	Custom

<sup>730</sup>Commercial and Industrial low pressure steam trap inlet pressure based on Franklin Energy and Opinion Dynamics analysis of data collected by Armstrong for 120,833 steam traps. Data covered coil, process, and radiator steam trap applications on modulating and constant pressure systems less than 15psi.

Medium and high pressure steam trap inlet pressure based on Navigant analysis of source collected during program implementation by Nicor Gas for GPY1 through GPY4. For each steam trap project, the data provided measure savings description, operating pressure, installation Zip code, business building type, program year, and annual operating hours. Dry cleaning steam trap inlet pressure based on C5 Steam Traps – Nicor FINAL 10.27.11.

<sup>731</sup> For applications where inlet pressures and orifice diameters are provided in the table, default values are directly calculated using the equation above. For the multifamily LPS space heating applications where inlet pressures and orifice diameters are not provided in the table, default values are assumptions based on engineering judgement and will be revisited in future years.

<sup>732</sup> Heat of vaporization of steam at the inlet pressure to the steam trap. Implicit assumption that the average boiler nominal pressure where the vaporization occurs, is essentially that same pressure. Referenced in CLEAResult "Work Paper Steam Traps Revision #2" Revision 3 dated March 2, 2012.

- Hs = Specific heat of water, (Btu/(lbm \* °R))  
= 1.001
- T<sub>source</sub> = Incoming water temperature  
= 513.67°R<sup>733</sup>
- η<sub>B</sub> = Boiler efficiency  
= custom, if unknown:  
= 80.7% for steam boilers, except multifamily low-pressure <sup>734</sup>  
= 64.8% for multifamily low-pressure steam boilers <sup>735</sup>
- Hours = Annual hours when steam system is pressurized  
= custom, if unknown:

Steam System	Zone (where applicable)	Hours/Yr <sup>736</sup>
Commercial Dry Cleaners	All Climate Zones	2,425
Industrial/Process Low Pressure: psig < 15		8,282
Medium Pressure: 15 ≤ psig < 30		8,282
Medium Pressure: 30 ≤ psig < 75		8,282
High Pressure: 75 ≤ psig < 125		8,282
High Pressure: 125 ≤ psig < 175		8,282
High Pressure: 175 ≤ psig < 250		8,282
High Pressure: 250 ≤ psig < 300		8,282
High Pressure: 300 ≤ psig		8,282
Commercial Space Heating LPS	Rockford	4,272
	Chicago	4,029
	Springfield	3,406
	Belleville	2,515
	Marion	2,546
Multifamily Space Heating LPS	<p>For steam traps that are part of steam systems where the boiler cycles on/off to maintain space setpoint temperature or for steam traps located downstream of a steam control valve that opens/closes to maintain setpoint temperature, use Heating EFLH values in Section 4.4 for High Rise or Mid-Rise MF buildings.</p> <p>For steam traps that are exposed to steam continuously throughout the heating season, use the values listed above for Commercial Space Heating LPS for your appropriate climate zone.</p>	

L = Leaking & blow-thru

<sup>733</sup> US DOE Building America Program. Building America Analysis Spreadsheet. For Chicago, IL.

<sup>734</sup> Ibid.

<sup>735</sup> Katrakis, J. and T.S. Zawacki. "Field-Measured Seasonal Efficiency of Intermediate-sized Low-Pressure Steam Boilers". ASHRAE V99, pt. 2, 1993.

<sup>736</sup> Medium and high-pressure steam trap annual operating hours based on Navigant analysis of source collected during program implementation by Nicor Gas for GPY1 through GPY4. For each steam trap project, the data provided measure savings description, operating pressure, installation Zip code, business building type, program year, and annual operating hours.

L is 1.0 when applied to the replacement of an individual leaking trap. If a number of steam traps are replaced and the system has not been audited, the leaking and blow-thru is applied to reflect the assumed percentage of steam traps that were actually leaking and need to be replaced. A custom value can be utilized if supported by an evaluation.

Steam System	L (%) <sup>737</sup>
Custom	Custom
Commercial Dry Cleaners	27%
Commercial Heating (including Multifamily) LPS	27%
Industrial/Process Low Pressure: psig < 15	16%
Medium Pressure: 15 ≤ psig < 30	16%
Medium Pressure: 30 ≤ psig < 75	16%
High Pressure: 75 ≤ psig < 125	16%
High Pressure: 125 ≤ psig < 175	16%
High Pressure: 175 ≤ psig < 250	16%
High Pressure: 250 ≤ psig < 300	16%

**For example**, a commercial dry cleaning facility with the default hours of operation and boiler efficiency;

$$\Delta\text{Therms} = Sa * (Hv + Hs * (T_1 - T_{\text{source}})) * \text{Hours} * L / (100,000 * \eta_B)$$

$$\begin{aligned} T_1 &= 507.89 * p_1^{0.0962} \\ &= 507.89 * (82.8 + 14.696)^{0.0962} \\ &= 789.1^\circ\text{R} \end{aligned}$$

$$\begin{aligned} \Delta\text{Therms} &= 18.5 \text{ lbs/hr/trap} * (890 \text{ Btu/lb} + 1.001 * (789.1^\circ\text{R} - 513.7^\circ\text{R})) * 2,425\text{hrs} * \\ &27\% / (100,000 * 80.7\%) \\ &= 175.0 \text{ therms per trap} \end{aligned}$$

### WATER IMPACT DESCRIPTIONS AND CALCULATION

The hourly water volume saved per each repaired or replaced leaking trap is calculated by dividing the “Average Actual Steam Loss per Leaking Trap (lbm/hr/trap)” by the density of water saved, 8.33 lbm/gal, that replaces the lost steam. The average actual steam loss is provided in the table for parameter *Sa*, the “Average actual steam loss per leaking trap” in the Fossil Fuel Savings section above. Annual water savings are calculated using *Hours* and *L*, the leaking and blow through factor, as defined above.

Water savings only apply to situations where condensate is lost from the steam system. If a condensate recovery system is in place, assume zero water savings or provide a custom calculation based on site-specific operation.

The annual water savings for a replaced or repaired trap is given by:

$$\Delta\text{Water} = \text{GAL} * \text{Hours} * L$$

Where:

**GAL** = average actual water volume saved per leaking trap, as listed in the following table and based on steam system type.

*Other variables as defined above.*

<sup>737</sup>Dry cleaners survey data as referenced in CLEAResult “Work Paper Steam Traps Revision #2” Revision 3 dated March 2, 2012.

Steam System*	Average Actual Steam Loss per Leaking Trap (lbm/hr/trap)	GAL: Average Actual Water Volume Saved per Leaking Trap Atmospheric Venting (gal/hr/trap)
Commercial Dry Cleaners	18.5	2.22
Multifamily LPS Space Heating	6.9	0.83
Commercial Heating (including Multifamily) LPS	13.8	1.66
Industrial/Process Low Pressure: psig < 15	13.8	1.66
Medium Pressure: 15 ≤ psig < 30	6.5	0.78
Medium Pressure: 30 ≤ psig < 75	23.4	2.81
High Pressure: 75 ≤ psig < 125	43.8	5.26
High Pressure: 125 ≤ psig < 175	60.9	7.31
High Pressure: 175 ≤ psig < 250	82.1	9.86
High Pressure: 250 ≤ psig < 300	105.2	12.63
High Pressure: 300 ≤ psig	Calculated	Calculated Steam Loss / 8.33

**DEEMED O&M COST ADJUSTMENT CALCULATION**

N/A

**MEASURE CODE: CI-HVC-STRE-V10-240101**

**REVIEW DEADLINE: 1/1/2025**

## 4.4.17 Variable Speed Drives for HVAC Pumps and Cooling Tower Fans

### DESCRIPTION

This measure is applied to variable speed drives (VSD) which are installed on the following HVAC system applications: chilled water pump, hot water pumps and cooling tower fans. There is a separate measure for HVAC supply and return fans. All other VSD applications require custom analysis by the program administrator. The VSD will modulate the speed of the motor when it does not need to run at full load. Since the power of the motor is proportional to the cube of the speed for these types of applications, significant energy savings will result.

This measure is not applicable for:

- Cooling towers, chilled or hot water pumps with any process load.
- VSD installation in existing cooling towers with 2-speed motors. (current code requires 2-speed motors for cooling towers with motors greater than 7.5 HP)
- VSD installation in new cooling towers with motors greater than 7.5 HP

This measure was developed to be applicable to the following program types: TOS, RF. If applied to other program types, the measure savings should be verified.

### DEFINITION OF EFFICIENT EQUIPMENT

The VSD is applied to a motor which does not have a VSD. This measure is not applicable for replacing failed VSDs. The application must have a variable load and installation is to include the necessary controls. Savings are based on application of VSDs to a range of baseline load conditions including no control, inlet guide vanes, outlet guide vanes and throttling valves.

### DEFINITION OF BASELINE EQUIPMENT

The time of sale baseline is a new motor installed without a VSD or other methods of control. Retrofit baseline is an existing motor operating as is. Retrofit baselines may or may not include guide vanes, throttling valves or other methods of control. This information shall be collected from the customer.

Installations of new equipment with VSDs which are required by IECC, state energy code as adopted by the State of Illinois are not eligible for incentives. As code requirements and adoption can differ from municipality to municipality, the user should verify which version of code is applicable given these constraints.

Note, IECC 2021 is expected to become effective statewide in 2023. IECC 2018 is the requisite code for any projects with permitting dates spanning July 1, 2019 to the IECC 2021 effective date. Prior to July 1, 2019, IECC 2015 is the applicable code.

### DEEMED LIFETIME OF EFFICIENT EQUIPMENT

The expected measure life for HVAC application is 15 years;<sup>738</sup> measure life for process is 15 years.<sup>739</sup>

### DEEMED MEASURE COST

Customer provided costs will be used when available. Default measure costs<sup>740</sup> are noted below for up to 20 hp motors. Custom costs must be gathered from the customer for motor sizes not listed below.

---

<sup>738</sup> Efficiency Vermont TRM 10/26/11 for HVAC VSD motors.

<sup>739</sup> DEER 2008.

<sup>740</sup> NEEP Incremental Cost Study Phase Two Final Report dated January 13, 2013.



HP	Cost
5 HP	\$ 2,250
15 HP	\$ 3,318
25 HP	\$ 4,386
50 HP	\$ 6,573
75 HP	\$ 8,532

### LOADSHAPE

- Loadshape C42 - VFD - Boiler feedwater pumps <10 HP
- Loadshape C43 - VFD - Chilled water pumps <10 HP
- Loadshape C44 - VFD Boiler circulation pumps <10 HP
- Loadshape C48 - VFD Boiler draft fans <10 HP
- Loadshape C49 - VFD Cooling Tower Fans <10 HP

### COINCIDENCE FACTOR

The demand savings factor (DSF) is already based upon coincident savings, and thus there is no additional coincidence factor for this characterization.

---



---

### Algorithm

---

### CALCULATION OF SAVINGS

#### ELECTRIC ENERGY SAVINGS

$$\Delta kWh = BHP / EFF_i * Hours * ESF$$

Where:

BHP = System Brake Horsepower  
(Nominal motor HP \* Motor load factor)

Motors are assumed to have a load factor of 65% for calculating kW if actual values cannot be determined<sup>741</sup>. Custom load factor may be applied if known.

EFF<sub>i</sub> = Motor efficiency, installed. Actual motor efficiency shall be used to calculate kW. If not known a default value of 93% shall be used.<sup>742</sup>

Hours = Default hours are provided for HVAC applications which vary by HVAC application and building type<sup>743</sup>. When available (provided via Energy Management Software or metered), actual hours should be used.

Building Type	Heating Run Hours	Cooling Run Hours	Model Source
Assembly	4888	2150	eQuest
Assisted Living	4711	4373	eQuest

<sup>741</sup> Del Balso, Ryan J. "Investigation into the Reliability of Energy Efficiency/Demand Side Management Savings Estimates for Variable Frequency Drives in Commercial Applications", University of Colorado, Department of Civil, Environmental and Architectural Engineering, 2013.

<sup>742</sup> Ohio TRM 8/6/2010 pp207-209, Com Ed TRM June 1, 2010.

<sup>743</sup> Hours per year are estimated using the eQuest or OpenStudio models as the total number of hours the heating or cooling system is operating for each building type. "Heating and Cooling Run Hours" are estimated as the total number of hours fans are operating for heating, cooling and ventilation for each building type. This may overclaim certain applications (e.g. pumps) and so where possible actual hours should be used for these applications.

Building Type	Heating Run Hours	Cooling Run Hours	Model Source
Auto Dealership	5270	1605	OpenStudio
College	7005	4065	OpenStudio
Convenience Store	4136	2084	eQuest
Drug Store	4940	1708	OpenStudio
Elementary School	6028	2649	OpenStudio
Emergency Services	3936	3277	OpenStudio
Garage	4849	2102	eQuest
Grocery	7452	5470	OpenStudio
Healthcare Clinic	8760	6364	OpenStudio
High School	5480	3141	eQuest
Hospital - VAV econ	8107	8707	OpenStudio
Hospital - CAV econ	3045	2336	OpenStudio
Hospital - CAV no econ	2927	4948	OpenStudio
Hospital - FCU	4371	8760	OpenStudio
Manufacturing Facility	3821	2805	eQuest
MF - High Rise	5168	6823	OpenStudio
MF - Mid Rise	6011	4996	OpenStudio
Hotel/Motel - Guest	5632	4155	OpenStudio
Hotel/Motel - Common	6340	6227	OpenStudio
Movie Theater	5063	2120	eQuest
Office - High Rise - VAV econ	5646	3414	OpenStudio
Office - High Rise - CAV econ	5361	4849	eQuest
Office - High Rise - CAV no econ	4202	6049	OpenStudio
Office - High Rise - FCU	4600	5341	OpenStudio
Office - Low Rise	3834	3835	OpenStudio
Office - Mid Rise	6119	3040	OpenStudio
Religious Building	5199	2830	eQuest
Restaurant	3476	2305	OpenStudio
Retail - Department Store	4249	2528	eQuest
Retail - Strip Mall	4475	2266	eQuest
Warehouse	4606	770	eQuest
Unknown	5038	2987	n/a

The type of hours to apply depends on the VFD application, according to the table below.

Application	Hours Type
Hot Water Pump	Heating
Chilled Water Pump	Cooling
Cooling Tower Fan	Cooling

ESF = Energy savings factor varies by VFD application. Units are kW/HP.

Application	ESF <sup>744</sup>
Hot Water Pump	0.249
Chilled Water Pump	0.081
Cooling Tower Fan	0.502

<sup>744</sup> Based on OpenStudio Large Office model, finding difference in energy use for each VSD application. See 'VSD ESF Calculation.xls'.

**SUMMER COINCIDENT PEAK DEMAND SAVINGS**

$$\Delta kW = BHP/EFFi * DSF$$

Where:

DSF = Demand Savings Factor varies by VFD application.<sup>745</sup> Units are kW/HP. Values listed below are based on typical peak load for the listed application.

Application	DSF
Hot Water Pump	0
Chilled Water Pump	0
Cooling Tower Fan	0.407

**FOSSIL FUEL IMPACT DESCRIPTIONS AND CALCULATION**

There are no expected fossil fuel impacts for this measure.

**WATER IMPACT DESCRIPTIONS AND CALCULATION**

N/A

**DEEMED O&M COST ADJUSTMENT CALCULATION**

N/A

**MEASURE CODE: CI-HVC-VSDHP-V10-240101**

**REVIEW DEADLINE: 1/1/2025**

---

<sup>745</sup> Based on OpenStudio Large Office model, finding difference in maximum demand for each VSD application. See 'VSD ESF Calculation.xls'.

4.4.18 Small Commercial Programmable Thermostats – Retired 12/31/2019. Replaced with  
4.4.48 Small Commercial Thermostats

## 4.4.19 Demand Controlled Ventilation

### DESCRIPTION

Demand control ventilation (DCV) adjusts outside ventilation air based on the number of occupants and the ventilation demands that those occupants create. DCV is part of a building's ventilation system control strategy. It may include hardware, software, and controls as an integral part of a building's ventilation design. Active control of the ventilation system provides the opportunity to reduce heating and cooling energy use.

The primary component is a control sensor to communicate either directly with the economizer or with a central computer. The component is most typically a carbon dioxide (CO<sub>2</sub>) sensor, occupancy sensor, or turnstile counter. This measure is applicable to multiple building types, and savings are classified by the specific building types defined in the Illinois TRM. This measure is modeled to assume night time set backs are in operation and minimum outside air is being used when the building is unoccupied. Systems that have static louvers or that are open at night will likely have greater savings by using the custom program.

Demand controlled ventilation controls can also be added to the exhaust fans to enclosed parking garages. The fans modulate the ventilation airflow based on pollutant concentrations (primarily carbon monoxide) in the space.

This measure does not apply to packaged single-zone (PSZ) rooftop units with functioning economizers. For PSZ with functioning economizers, see 4.4.41 Advanced Rooftop Controls.

This measure was developed to be applicable to the following program types: RF. If applied to other program types, the measure savings should be verified.

### DEFINITION OF EFFICIENT EQUIPMENT

The efficient equipment condition is defined by new CO<sub>2</sub> sensors installed on return air systems where no other sensors were previously installed. For heating savings, this measure does not apply to any system with terminal reheat (constant volume or variable air volume). For terminal reheat system a custom savings calculation should be used.

### DEFINITION OF BASELINE EQUIPMENT

The base case for this measure is a space with no demand control capability. The current code minimum for outside air (OA) is 5 CFM per occupant (ASHRAE 62.1 - 2016) which is the value for office space assumed in this measure.

This measure does not apply to packaged single-zone (PSZ) rooftop units with functioning economizers. For PSZ with functioning economizers, see 4.4.41 Advanced Rooftop Controls.

### DEEMED LIFETIME OF EFFICIENT EQUIPMENT

The deemed measure life is 10 years and based on CO<sub>2</sub> sensor estimated life.<sup>746</sup>

### DEEMED MEASURE COST

The deemed measure cost is assumed to be the full cost of installation of a DCV retrofit including sensor cost (\$278) and RTU integration cost(\$900per zone) for a total of \$1,178.<sup>747</sup>

---

<sup>746</sup> During conversations with vendors and Building Automation System (BAS) contractors, it was determined that sensors must be functional for up to 10 years. It is recommended that they are part of a normal preventive maintenance program in which calibration is an important part of extending useful life. Although they are not subject to mechanical failure, they do fall out of tolerance over time.

<sup>747</sup> [Business Energy Advisor | Demand-Controlled Ventilation \(bizenergyadvisor.com\)](https://www.bizenergyadvisor.com), 2017. Average sensor cost used from list of eight different vendors and CO<sub>2</sub> sensors. RTU integration costs assume high end of estimated range (\$300-\$900) for implementing DCV on a newer DCV-ready RTU with existing economizer.

Adding demand controlled ventilation to parking garages is assumed to cost \$500 per sensor including the cost of the controller. The installation cost is estimated at \$1,000 for labor.<sup>748</sup>

**LOADSHAPE**

Commercial ventilation C23

**COINCIDENCE FACTOR**

N/A

---



---

**Algorithm**

---



---

**CALCULATION OF ENERGY SAVINGS**

**ELECTRIC ENERGY SAVINGS**

For facilities heated by natural gas,

$$\Delta kWh = \text{Condition Space}/1000 * SF_{cooling}$$

For facilities heated by heat pumps,

$$\Delta kWh = \text{Condition Space}/1000 * SF_{cooling} + \text{Condition Space}/1000 * SF_{Heat HP}$$

For facilities heated by electric resistance,

$$\Delta kWh = \text{Condition Space}/1000 * SF_{cooling} + \text{Condition Space}/1000 * SF_{Heat ER}$$

Where:

- Conditioned Space = actual square footage of conditioned space controlled by sensor
- SF<sub>cooling</sub> = Cooling Savings Factor  
= value in table below based on building type and weather zone
- SF<sub>Heat HP</sub> = Heating Savings factor for facilities heated by Heat Pump (HP)  
= value in table below based on building type and weather zone
- SF<sub>Heat ER</sub> = Heating Savings factor for facilities heated by Electric Resistance (ER)  
= value in table below based on building type and weather zone

Saving Factor Tables<sup>749</sup>

Building Type	SF <sub>cooling</sub> (kWh/1000 SqFt)				
	Zone 1 (Rockford)	Zone 2 (Chicago)	Zone 3 (Springfield)	Zone 4 (Belleville)	Zone 5 (Marion)
Office - Low-rise	285	289	299	298	305
Office - Mid-rise	225	228	234	233	237
Office - High-rise	267	271	279	279	284
Religious Building	763	780	886	889	910

<sup>748</sup> California Utilities Statewide Codes and Standards Team. 2011. "2013 California Building Energy Efficiency Standards", Garage Exhaust, Section 4.2 Page 14.

<sup>749</sup> The electric energy savings was calculated using TMY3 weather data and methodology consistent with ASHRAE standards. Savings are calculated on an annual basis for each given temperature zone in Illinois. Energy savings for DCV were developed utilizing standards, inputs and approaches as set forth by ASHRAE 90.1 -2010 (code level up until Dec 31, 2015). Building input parameters like square footage, equipment efficiencies and occupancy match those used in the EFLH calculations. Reference calculation found in Demand Control Ventilation 12-30-13.xls.

Building Type	SF <sub>cooling</sub> (kWh/1000 SqFt)				
	Zone 1 (Rockford)	Zone 2 (Chicago)	Zone 3 (Springfield)	Zone 4 (Belleville)	Zone 5 (Marion)
Restaurant	498	510	573	593	615
Retail - Department Store	388	393	410	415	423
Retail - Strip Mall	269	272	285	285	290
Convenience Store	355	357	368	370	374
Elementary School	358	367	410	405	415
High School	350	359	401	396	406
College/University	400	426	472	488	519
Healthcare Clinic	349	354	389	392	398
Lodging	407	409	423	424	428
Manufacturing	175	177	183	248	185
Special Assembly Auditorium	563	581	668	677	711
Default (non-garage)	377	385	419	426	433
Enclosed Parking Garage <sup>750</sup>	925	925	925	925	925

Building Type	SF <sub>Heat HP</sub> (kWh/1000 SqFt)				
	Zone 1 (Rockford)	Zone 2 (Chicago)	Zone 3 (Springfield)	Zone 4 (Belleville)	Zone 5 (Marion)
Office - Low-rise	234	205	181	171	147
Office - Mid-rise	157	138	121	115	99
Office - High-rise	211	185	163	154	133
Religious Building	1,508	1,333	1,180	1,125	1,008
Restaurant	1,067	962	837	816	720
Retail - Department Store	368	329	291	285	249
Retail - Strip Mall	246	215	195	186	165
Convenience Store	180	163	141	138	121
Elementary School	657	572	508	473	418
High School	641	558	495	461	406
College/University	1,267	1,114	980	945	798
Healthcare Clinic	447	396	348	334	299
Lodging	205	184	159	154	135
Manufacturing	130	114	101	172	83
Special Assembly Auditorium	1,773	1,564	1,414	1,378	1,212
Default (non-garage)	606	535	474	460	400

Building Type	SF <sub>Heat ER</sub> (kWh/1000 SqFt)				
	Zone 1 (Rockford)	Zone 2 (Chicago)	Zone 3 (Springfield)	Zone 4 (Belleville)	Zone 5 (Marion)
Office - Low-rise	703	615	542	512	441
Office - Mid-rise	471	413	364	345	298
Office - High-rise	633	554	489	462	398
Religious Building	4,523	3,999	3,541	3,376	3,024
Restaurant	3,201	2,886	2,511	2,449	2,159
Retail - Department Store	1,103	987	874	855	748

<sup>750</sup> Savings are estimated based on a study done by California Utilities Statewide Codes and Standards Team, “2013 California Building Energy Efficiency Standards”, 2013, Section 2.4, Table 1. The savings are primarily fan savings, and are not dependent on climate zone.

Building Type	SF <sub>Heat ER</sub> (kWh/1000 SqFt)				
	Zone 1 (Rockford)	Zone 2 (Chicago)	Zone 3 (Springfield)	Zone 4 (Belleville)	Zone 5 (Marion)
Retail - Strip Mall	738	646	584	559	495
Convenience Store	541	488	423	413	364
Elementary School	1,972	1,715	1,523	1,420	1,254
High School	1,924	1,673	1,484	1,383	1,219
College/University	3,801	3,341	2,940	2,834	2,394
Healthcare Clinic	1,341	1,188	1,044	1,001	896
Lodging	616	551	477	462	406
Manufacturing	390	343	303	516	250
Special Assembly Auditorium	5,320	4,691	4,243	4,133	3,636
Default (non-garage)	1,819	1,606	1,423	1,381	1,199

**For example**, for a 7,500 SqFt of low-rise office space in Chicago with gas heat.

$$\begin{aligned} \Delta kWh &= 7,500 / 1000 * 289 \\ &= 2,168 \text{ kWh} \end{aligned}$$

**SUMMER COINCIDENT PEAK DEMAND SAVINGS**

NA

**FOSSIL FUEL SAVINGS**

$$\Delta \text{therms} = \text{Condition Space} / 1000 * SF_{\text{Heat Gas}}$$

Where:

SF<sub>Heat Gas</sub> = value in table below based on building type and weather zone.<sup>751</sup>

Building Type	SF <sub>Heat Gas</sub> (Therm/1000 sq ft)				
	Zone 1 (Rockford)	Zone 2 (Chicago)	Zone 3 (Springfield)	Zone 4 (Belleville)	Zone 5 (Marion)
Office - Low-rise	30	26	23	22	19
Office - Mid-rise	20	18	16	15	13
Office- High-rise	27	24	21	20	17
Religious Building	193	171	151	144	129
Restaurant	137	123	107	104	92
Retail - Department Store	47	42	37	36	32
Retail - Strip Mall	31	28	25	24	21
Convenience Store	23	21	18	18	16
Elementary School	84	73	65	61	53
High School	82	71	63	59	52
College/ University	162	143	125	121	102
Healthcare Clinic	57	51	45	43	38
Lodging	26	23	20	20	17
Manufacturing	17	15	13	22	11

<sup>751</sup> The natural gas energy savings was calculated using TMY3 weather data and methodology consistent with ASHRAE standards. Savings are calculated on an annual basis for each given temperature zone in Illinois. Energy savings for DCV were developed utilizing standards, inputs and approaches as set forth by ASHRAE 62.1 and 90.1, respectively. Building input parameters like square footage, equipment efficiencies and occupancy match those used in the EFLH calculations. Reference calculation found in Demand Control Ventilation 12-30-13.xls.



Building Type	SF <sub>Heat Gas</sub> (Therm/1000 sq ft)				
	Zone 1 (Rockford)	Zone 2 (Chicago)	Zone 3 (Springfield)	Zone 4 (Belleville)	Zone 5 (Marion)
Special Assembly Auditorium	227	200	181	176	155
De-fault	78	68	61	59	51

**For example**, for a 7500 SqFt of low-rise office space in Chicago.

$$\begin{aligned} \Delta\text{Therms} &= 7,500/1,000 * 26 \\ &= 195 \text{ Therms} \end{aligned}$$

**WATER IMPACT DESCRIPTIONS AND CALCULATION**

N/A

**DEEMED O&M COST ADJUSTMENT CALCULATION**

N/A

**MEASURE CODE: CI-HVC-DCV-V07-240101**

**REVIEW DEADLINE: 1/1/2027**

## 4.4.20 High Turndown Burner for Space Heating Boilers

### DESCRIPTION

This measure is for a non-residential boilers equipped with linkageless controls providing space heating with burners having a turndown less than 6:1.<sup>752</sup> Turndown is the ratio of the high firing rate to the low firing rate. When boilers are subjected to loads below the low firing rate, the boiler must cycle on/off to meet the load requirements. A higher turndown ratio reduces burner startups, provides better load control, saves wear-and-tear on the burner, and reduces purge-air requirements, all of these benefits result in better overall efficiency.

This measure was developed to be applicable to the following program types: NC, TOS, RF.

If applied to other program types, the measure savings should be verified.

### DEFINITION OF EFFICIENT EQUIPMENT

To qualify the boiler linkageless burner must operate with a turndown greater than or equal to 10:1 and be subjected to loads less than or equal to 30% of the full fire input MBH<sup>753</sup> for greater than 60% of the operating hours.<sup>754</sup>

### DEFINITION OF BASELINE EQUIPMENT

The baseline boiler utilizes a linkageless burner with a turndown ration of 6:1 or less and is used primarily for space heating. Redundant boilers do not qualify. Code requirements must be considered.

Note: beginning with the 2015 edition, and continuing through the 2021 edition, IECC makes the following requirements for boiler turndown:

*Boiler Systems* with design input of greater than 1,000,000 Btu/h shall comply with the turndown ratio specified in the following table.

The system turndown requirement shall be met through the use of multiple single-input boilers, one or more *modulating boilers* or a combination of single-input and *modulating boilers*.

BOILER SYSTEM DESIGN INPUT	MINIMUM TURNDOWN RATIO
≥ 1,000,000 and less than or equal to 5,000,000	3 to 1
> 5,000,000 and less than or equal to 10,000,000	4 to 1
> 10,000,000	5 to 1

### DEEMED LIFETIME OF EFFICIENT EQUIPMENT

The expected measure life is assumed to be the lower of remaining useful life of the boiler, or 21 years.<sup>755</sup>

### DEEMED MEASURE COST

Actual costs shall be used as available. When unknown, the deemed installed measure cost including labor is approximately \$2.53/MBtu/hr.<sup>756</sup>

<sup>752</sup> The standard turndown ratio for boilers is 6:1. Understanding Fuel Savings in the Boiler Room, ASHRAE Journal, David Eoff, December, 2008 p 38.

<sup>753</sup> Focus on Energy Evaluation, Business Programs: Deemed Savings Manual V1.0, March 22, 2010. This factor implies that boilers are 30% oversized on average.

<sup>754</sup> FES Analysis of bin hours based upon a 30% oversizing factor.

<sup>755</sup> "Burner," Obtained from a nation-wide survey conducted by ASHRAE TC 1.8 (Akalin 1978). Data changed by TC 1.8 in 1986.

<sup>756</sup> FES review of PY2/PY3 costs for custom People's and North Shore high turndown burner projects. See High Turndown Costs.xlsx for details.

**DEEMED O&M COST ADJUSTMENTS**

N/A

**LOADSHAPE**

N/A

**COINCIDENCE FACTOR**

N/A

---



---

**Algorithm**

---



---

**CALCULATION OF SAVINGS**

**ELECTRIC ENERGY SAVINGS**

N/A

**SUMMER COINCIDENT PEAK DEMAND SAVINGS**

N/A

**FOSSIL FUEL SAVINGS**

$$\Delta \text{therms} = \text{Ngi} * \text{SF} * \text{EFLH} / 100$$

Where:

Ngi = Boiler gas input size (kBtu/hr) = custom

SF = Savings Factor = Percentage of energy loss per hour  
 =  $(\sum ((\text{EL\_base} - \text{EL\_eff}) * \text{H\_cycling})) / \text{H}) * 100$

Where:

EL\_base = Base Boiler Percentage of energy loss due to cycling at % of Base Boiler Load where  
 BL\_base ≤ TDR\_base

$$= 0.003 * (\text{Cycles\_base})^2 - 0.001 * \text{Cycles\_base}^{757}$$

Where:

Cycles\_base = Number of Cycles/hour of base boiler

$$= \text{TDR\_base} / \text{BL}$$

Where:

BL = % of full boiler load at bin hours being evaluated. This is assumed to be a straight line based on 0% load at the building balance point (assumed to be 55F), and full load corrected for the oversizing (OSF) at the lowest temperature bin of -10 to -5F.

OSF = Oversizing Factor = 1.3,<sup>758</sup> or custom

---

<sup>757</sup> Release 3.0 Operations & Maintenance Best Practices A Guide to Achieving Operational Efficiency, August 2010, Federal Energy Management Program, US Department of Energy. The equation was determined by plotting the values in Table 9.2.1 – Boiler Cycling Energy Loss.

<sup>758</sup> PA Consulting, KEMA, Focus on Energy Evaluation, Business Programs: Deemed Savings Manual V1.0, March 22, 2010, Page 4-12.

TDR\_base = Turndown ratio = 0.33,<sup>759</sup> or custom

EL\_eff = Efficient Boiler Percentage of energy loss due to cycling at % of Efficient Boiler Load  
 = 0.003 \* (Cycles\_eff)<sup>2</sup> – 0.001 \* Cycles\_eff

Where:

Cycles\_eff = Number of Cycles/hour  
 = TDR\_eff / BL

Where:

TDR\_eff = Turndown ratio = 0.10,<sup>760</sup> or custom

H\_cycling = Hours base boiler is cycling at % of base boiler load  
 = see table below or custom

H = Total Number of Hours in Heating Season  
 = 4,946 or custom

100 = convert to a percentage

SF = 69.1 / 4946 \*100 = 1.4% or custom (see table below for summary of values)

Temperature	H_cycling	BL	EL_base	EL_eff	(EL_base-EL_eff)* Hours
50 to 55	601	6.0%	8.5%	0.7%	47.2
45 to 50	603	12.0%	2.0%	0.0%	12.0
40 to 45	455	18.0%	0.8%	0.0%	3.8
35 to 40	925	24.0%	0.4%	0.0%	4.0
30 to 35	814	30.0%	0.3%	0.0%	2.1
Total					69.1

EFLH = Equivalent Full Load Hours for heating in Existing Buildings or New Construction are provided in section 4.4 HVAC End Use.

100 = convert kBtu to therms

**Water IMPACT DESCRIPTIONS AND CALCULATION**

N/A

**DEEMED O&M COST ADJUSTMENT CALCULATION**

N/A

**MEASURE CODE: CI-HVAC-HTBC-V06-230101**

**REVIEW DEADLINE: 1/1/2024**

<sup>759</sup> Ibid.

<sup>760</sup> 10:1 ratio used to qualify for efficient equipment.

## 4.4.21 Linkageless Boiler Controls for Space Heating

### DESCRIPTION

This measure is for a non-residential boiler providing space heating with single point positioning combustion control. In single-point positioning control, the fuel valve is linked to the combustion air damper via a jackshaft mechanism to maintain correspondence between fuel and combustion air input. Most boilers with single point positioning control do not maintain low excess air levels over their entire firing range. Generally, these boilers are calibrated at high fire, but due to the non-linearity required for efficient combustion, excess air levels tend to dramatically increase as the firing rate decreases. Boiler efficiency drops as the excess air levels are increased.

This measure was developed to be applicable to the following program types: TOS, NC, RF.  
If applied to other program types, the measure savings should be verified.

### DEFINITION OF EFFICIENT EQUIPMENT

To qualify the boiler burner must have a linkageless control system allowing the combustion air damper position to be adjusted and set for optimal efficiency at several firing rates throughout the burner's firing range. This requires the fuel valve and combustion air damper to each be powered by a separate actuator. An alternative to the combustion air damper is a Variable Speed Drive on the combustion air fan.

### DEFINITION OF BASELINE EQUIPMENT

The baseline boiler utilizes single point positioning for the burner combustion control.

### DEEMED LIFETIME OF EFFICIENT EQUIPMENT

The expected measure life is assumed to be 20 years.<sup>761</sup>

### DEEMED MEASURE COST

The deemed measure cost is estimated at \$8,500.<sup>762</sup>

### DEEMED O&M COST ADJUSTMENTS

N/A

### LOADSHAPE

N/A

### COINCIDENCE FACTOR

N/A

---

<sup>761</sup> Ontario Energy Board, "Final Report: Custom Measure Life", Michaels Energy, May 10, 2018, burner modification measure life is estimated at 20 years.

<sup>762</sup> Codes and Standards Enhancement Initiative (CASE) – Commercial Boilers; 2013 California Building Energy Efficiency Standards, California Utilities Statewide Codes and Standards Team, October 2011 (pg. 19). The estimated incremental costs were provided by boiler control representatives and did not vary with boiler capacity. The \$8,500 estimated incremental cost represents the mid-point of the estimated price range.

**Algorithm**

**CALCULATION OF SAVINGS**

**ELECTRIC ENERGY SAVINGS**

When a Variable Speed Drive is incorporated, electrical savings are calculated according to the “4.4.17 Variable Speed Drive for HVAC Pumps and Cooling Tower Fans” measure.

**SUMMER COINCIDENT PEAK DEMAND SAVINGS**

N/A

**FOSSIL FUEL SAVINGS**

$$\Delta \text{Therms} = \text{Ngi} * \text{SF} * \text{EFLH} / 100$$

Where:

Ngi = Boiler gas input size (kBtu/hr) = custom

SF = Savings factor

Note: Savings factor is the percentage increase in efficiency as a result of the addition of linkageless burner controls. At an average boiler load of 35%, single point controls are assumed to have excess air of 91%, while linkageless controls are assumed to have 34% excess air.<sup>763</sup> The difference between controls types is 57% at this average operating condition. A 15% reduction in excess air is approximately a 1% increase in efficiency.<sup>764</sup> Therefore the nominal combustion efficiency increase is  $57 / 15 * 1\% = 3.8\%$ .

$$= 3.8\%$$

EFLH = Equivalent Full Load Hours for heating in Existing Buildings or New Construction are provided in section 4.4 HVAC End Use

100 = convert kBtu to therms

**WATER IMPACT DESCRIPTIONS AND CALCULATION**

N/A

**DEEMED O&M COST ADJUSTMENT CALCULATION**

N/A

**MEASURE CODE: CI-HVC-LBC-V06-220101**

**REVIEW DEADLINE: 1/1/2027**

<sup>763</sup> Available and Emerging Technologies for Reducing Greenhouse Gas Emissions from Industrial, Commercial, and Institutional Boilers, Prepared by the Sector Policies and Programs Division Office of Air Quality Planning and Standards U.S. Environmental Protection Agency Research Triangle Park, North Carolina 27711, October 2010, Table 1. ICI Boilers – Summary of Greenhouse Gas Emission Reduction Measures, pg. 8.

<sup>764</sup> Department of Energy (DOE). January 2012, Steam Tip Sheet #4, Improve Your Boiler’s Combustion Efficiency. Advanced Manufacturing Office. Washington, DC: U.S. Department of Energy. This value was determined as an appropriate average over the stack temperatures and excess air levels indicated.

## 4.4.22 Oxygen Trim Controls for Space Heating Boilers

### DESCRIPTION

This measure is for a non-residential boiler providing space heating without oxygen trim combustion controls. Oxygen (O<sub>2</sub>) trim controls limit the amount of excess oxygen provided to the burner for combustion. This oxygen level is dependent upon the amount of air provided. Oxygen trim control converts parallel positioning, linkageless controls, into a closed-loop control configuration with the addition of an exhaust gas analyzer and PID controller. Boilers with oxygen trim controls can maintain a predetermined excess air rate (generally 15% to 30% excess air) over the entire burner firing rate. Boilers without these controls typically have excess air rates around 30% over the entire firing rate. Boiler efficiency drops as the excess air levels are increased.

This measure was developed to be applicable to the following program types: NC, TOS, RF.

If applied to other program types, the measure savings should be verified.

### DEFINITION OF EFFICIENT EQUIPMENT

To qualify the boiler burner must have an oxygen control system allowing the combustion air to be adjusted to maintain a predetermined excess oxygen level in the flue exhaust at all firing rates throughout the burner's firing range. This requires an oxygen sensor in the flue exhaust and linkageless fuel valve and combustion air controls.

### DEFINITION OF BASELINE EQUIPMENT

The baseline boiler utilizes single point positioning for the burner combustion control.

### DEEMED LIFETIME OF EFFICIENT EQUIPMENT

The measure life for the O<sub>2</sub> Trim controls is 20 years.<sup>765</sup>

### DEEMED MEASURE COST

The deemed measure cost is approximately \$23,250.<sup>766</sup>

### LOADSHAPE

N/A

### COINCIDENCE FACTOR

N/A

---

### Algorithm

---

### CALCULATION OF SAVINGS

#### ELECTRIC ENERGY SAVINGS

N/A

#### SUMMER COINCIDENT PEAK DEMAND SAVINGS

N/A

---

<sup>765</sup> Ontario Energy Board, "Final Report: Custom Measure Life", Michaels Energy, May 10, 2018, burner modification measure life is estimated at 20 years.

<sup>766</sup> CODES AND STANDARDS ENHANCEMENT INITIATIVE (CASE) PROCESS BOILERS, 2013 California Building Energy Efficiency Standards, California Utilities Statewide Codes and Standards Team, October 2011, pg. 22.

### FOSSIL FUEL SAVINGS

$$\Delta\text{Therms} = \text{Ngi} * \text{SF} * \text{EFLH} / 100$$

Where:

Ngi = Boiler gas input size (kBtu/hr)

= Custom

SF = Savings factor

Note: Savings factor is the percentage reduction in gas consumption as a result of the addition of O<sub>2</sub> trim controls. Linkageless controls have an excess air rate of 28% over the entire firing range.<sup>767</sup> O<sub>2</sub> trim controls have an excess air rate of 15%.<sup>768</sup> The average difference is 13%. A 15% reduction in excess air is approximately a 1% increase in efficiency.<sup>769</sup> Therefore, the nominal combustion efficiency increase is  $13 / 15 * 1\% = 0.87\%$ .

= 0.87%

EFLH = Default Equivalent Full Load Hours for heating in Existing Buildings or New Construction are provided in section 4.4 HVAC End Use. When available, actual hours should be used.

100 = convert kBtu to therms

### WATER IMPACT DESCRIPTIONS AND CALCULATION

N/A

### DEEMED O&M COST ADJUSTMENT CALCULATION

The deemed annual Operations and Maintenance cost is \$800.<sup>770</sup>

**MEASURE CODE: CI-HVC-O2TC-V02-220101**

**REVIEW DEADLINE: 1/1/2026**

---

<sup>767</sup> Department of Energy (DOE). 2009. Energy Matters newsletter. Fall 2009- Vol. 1, Iss. 1. Washington, DC: U.S. Department of Energy, Office of Energy Efficiency and Renewable Energy, Industrial Technologies Program.

<sup>768</sup> Ibid.

<sup>769</sup> Department of Energy (DOE), January 2012, Steam Tip Sheet #4, Improving Your Boiler's Combustion Efficiency. Advanced Manufacturing Office. Washington, DC: U.S. Department of Energy. This value was determined as an appropriate average over the stack temperatures and excess air levels indicated.

<sup>770</sup> CODES AND STANDARDS ENHANCEMENT INITIATIVE (CASE) PROCESS BOILERS, 2013 California Building Energy Efficiency Standards, California Utilities Statewide Codes and Standards Team, October 2011, pg. 22.



## 4.4.23 Shut Off Damper for Space Heating Boilers or Furnaces

### DESCRIPTION

This measure is for non-residential atmospheric boilers or furnaces providing space heating without a shut off damper. When appliances are on standby mode warm room air is drawn through the stack via the draft hood or dilution air inlet at a rate proportional to the stack height, diameter and outdoor temperature. More air is drawn through the vent immediately after the appliance shuts off and the flue is still hot. Installation of a new shut off damper can prevent heat from being drawn up the warm vent and reducing the amount of air that passes through the furnace or boiler heat exchanger. This reduction in air can slightly increase overall operating efficiency by reducing the time needed to achieve steady-state operating conditions.

This measure was developed to be applicable to the following program types: RF.

If applied to other program types, the measure savings should be verified.

### DEFINITION OF EFFICIENT EQUIPMENT

To qualify the space heating boiler or furnace must have a new electrically or thermally activated shut off damper installed on either the exhaust flue or combustion air intake. Barometric dampers do not qualify. The damper actuation shall be interlocked with the firing controls.

### DEFINITION OF BASELINE EQUIPMENT

The baseline boiler or furnace incorporates no shut off damper on the combustion air intake or flue exhaust.

### DEEMED LIFETIME OF EFFICIENT EQUIPMENT

The measure life for the shut off damper is 15 years,<sup>771</sup> or for the remaining lifetime of the heating equipment, whichever is less.

### DEEMED MEASURE COST

Given the variability in cost associated with differences in system specifications and design, as well as choice of measure technology, actual installed costs should be used as available or based on program-specific qualification requirements. When unavailable, a deemed measure cost of \$1,500 shall be assumed.<sup>772</sup>

### LOADSHAPE

N/A

### COINCIDENCE FACTOR

N/A

---

---

### Algorithm

---

### CALCULATION OF SAVINGS

### ELECTRIC ENERGY SAVINGS

N/A

---

<sup>771</sup> State of Wisconsin Public Service Commission of Wisconsin Focus on Energy Evaluation Business Programs: Measure Life Study Final Report: August 25, 2009, Table 1-2. Recommended Measure Life by WISEerts Group Description, pg. 1-4.

<sup>772</sup> CODES AND STANDARDS ENHANCEMENT INITIATIVE (CASE) PROCESS BOILERS, 2013 California Building Energy Efficiency Standards, California Utilities Statewide Codes and Standards Team, October 2011, pg. 22.

**SUMMER COINCIDENT PEAK DEMAND SAVINGS**

N/A

**FOSSIL FUEL SAVINGS**

$$\Delta\text{Therms} = \text{Ngi} * \text{SF} * \text{EFLH} / 100$$

Where:

Ngi = Boiler gas input size (kBtu/hr)

= Custom

SF = Savings factor

= 1%<sup>773</sup>

Note: The savings factor assumes the boiler or furnace is located in an unconditioned space. The savings factor can be higher for those units located within conditioned space.

EFLH = Default Equivalent Full Load Hours for heating in Existing Buildings are provided in section 4.4 HVAC End Use. When available, actual hours should be used.

100 = convert kBtu to therms

**WATER IMPACT DESCRIPTIONS AND CALCULATION**

N/A

**DEEMED O&M COST ADJUSTMENT CALCULATION**

A deemed, one-time Operations and Maintenance cost of \$150<sup>774</sup> shall be included in cost-effectiveness calculations and occur in year 10 of the measure life to account for controller replacement.

**MEASURE CODE: CI-HVC-SODP-V03-240101**

**REVIEW DEADLINE: 1/1/2029**

---

<sup>773</sup> Based on internet review of savings potential;

“Up to 4%”: Use of Automatic Vent Dampers for New and Existing Boilers and Furnaces, Energy Innovators Initiative Technical Fact Sheet, Office of Energy Efficiency, Canada, 2002

“Up to 1%”: Page 9, The Carbon Trust, “Steam and high temperature hot water boilers”, March 2012,

“1 - 2%”: Page 2, Sustainable Energy Authority of Ireland “Steam Systems Technical Guide”.

<sup>774</sup> CODES AND STANDARDS ENHANCEMENT INITIATIVE (CASE) PROCESS BOILERS, 2013 California Building Energy Efficiency Standards, California Utilities Statewide Codes and Standards Team, October 2011, pg. 22.

## 4.4.24 Small Pipe Insulation

### DESCRIPTION

This measure provides rebates for adding insulation to bare pipes with inner diameters of ½” and ¾”. Insulation must be at least one inch thick. Since new construction projects are required by code to have pipe insulation, this measure is only for retrofits of existing facilities. This covers bare straight pipe as well as all fittings.

Default savings are provided on a per linear foot basis. It is assumed that the majority of pipes less than one inch in commercial facilities are used for domestic hot water. However, this measure can cover hydronic heating systems as well as low and high pressure steam systems.

This measure was developed to be applicable to the following program types: RF.

If applied to other program types, the measure savings should be verified.

### DEFINITION OF EFFICIENT EQUIPMENT

The efficient case is a ½” or ¾” diameter pipe with at least one inch of insulation. Insulation must be protected from damage which includes moisture, sunlight, equipment maintenance and wind. Outdoor pipes should have a weather protective jacket. Insulation must be continuous over straight pipe, elbows and tees.

### DEFINITION OF BASELINE EQUIPMENT

The base case for savings estimates is a bare hot water or steam pipe with a fluid temperature of 105 degrees Fahrenheit or greater. Current new construction code requires insulation amounts similar to this measure, though this base case is commonly found in older existing buildings.

### DEEMED LIFETIME OF EFFICIENT EQUIPMENT

The measure life is assumed to be 15 years.<sup>775</sup>

### DEEMED MEASURE COST

The incremental measure cost for insulation is the full cost of adding insulation to the pipe. Actual installation costs should be used for the measure cost. For planning purposes, the following costs can be used to estimate the full cost of materials and labor.<sup>776</sup>

Insulation Thickness	¾” pipe	½” pipe
1”	\$4.45	\$4.15

### LOADSHAPE

N/A

### COINCIDENCE FACTOR

N/A

---

<sup>775</sup> Measure Life Report, Residential and Commercial/Industrial Lighting and HVAC Measures, GDS Associates, June 2007.

<sup>776</sup> A market survey was performed to determine these costs.

**Algorithm**

**CALCULATION OF ENERGY SAVINGS**

**ELECTRIC ENERGY SAVINGS**

N/A

**SUMMER COINCIDENT PEAK DEMAND SAVINGS**

N/A

**FOSSIL FUEL SAVINGS**

$$\Delta\text{Therms per foot}^{777} = [(Q_{\text{base}} - Q_{\text{eff}}) * \text{EFLH}] / (100,000 * \eta_{\text{Boiler}}) * \text{TRF}$$

$$= [\text{Modeled or provided by tables below}] * \text{TRF}$$

$$\Delta\text{Therms} = (L_{\text{sp}} + L_{\text{oc,i}}) * \Delta\text{therms per foot}$$

Where:

**EFLH** = Equivalent Full Load Hours for Heating  
 = Actual or defaults by building type in Existing Buildings provided in Section 4.4, HVAC end use

For year round recirculation or domestic hot water:

$$= 8,766$$

For heating season recirculation, hours with the outside air temperature below 55°F:

Zone	Hours
Zone 1 (Rockford)	5,039
Zone 2 (Chicago)	4,963
Zone 3 (Springfield)	4,495
Zone 4 (Belleville/	4,021
Zone 5 (Marion)	4,150

**Q<sub>base</sub>** = Heat Loss from Bare Pipe (Btu/hr/ft)  
 = Calculated where possible using 3E Plusv4.0 software. For defaults see table below

**Q<sub>eff</sub>** = Heat Loss from Insulated Pipe (Btu/hr/ft)  
 = Calculated where possible using 3E Plusv4.0 software. For defaults see table below

**100,000** = conversion factor (1 therm = 100,000 Btu)

**η<sub>Boiler</sub>** = Efficiency of the boiler being used to generate the hot water or steam in the pipe  
 = 81.9% for water boilers<sup>778</sup>  
 = 80.7% for steam boilers, except multifamily low-pressure<sup>779</sup>

<sup>777</sup>This value comes from the reference table “Savings Summary by Building Type and System Type.” The formula and the input tables in this section document assumptions used in calculation spreadsheet “Pipe Insulation Savings 2013-11-12.xlsx”.

<sup>778</sup> Average efficiencies of units from the California Energy Commission (CEC).

<sup>779</sup> Ibid.

= 64.8% for multifamily low-pressure steam boilers.<sup>780</sup>

TRF = Thermal Regain Factor for pipe location and use, see table below. The Custom TRF option may be used on any pipe location, including pipe locations with deemed TRFs specifically listed in the table below, if supporting justification and calculations for the Custom TRF are provided.

May vary seasonally such as:  $TRF[summer] * \text{summer hours} + TRF[winter] * \text{winter hours}$  where TRF values reflecting summer and winter conditions are apportioned by the hours for those conditions. TRF may also be adjusted by building specific balance point temperature (BPT) and operating hours above and below that BPT.<sup>781</sup>

Pipe Location	Assumed Regain	TRF, Thermal Regain Factor
Outdoor	0%	1.0
Indoor, conditioned space during the heating season, 55°F BPT	85%	0.15
Indoor, conditioned space, not during the heating season, 55°F BPT	0%	1.0
Indoor, conditioned, annual use (e.g. hot water or process loads), 55°F BPT	45%	0.55
Indoor, semi- conditioned, (unconditioned space, with heat transfer to conditioned space. E.g., boiler room, ceiling plenum, basement, crawlspace, wall), during the heating season, 55°F BPT	30%	0.70
Indoor, semi-conditioned, not during the heating season, 55°F BPT	0%	1.0
Indoor, semi-conditioned, annual use, 55°F BPT	16%	0.84
Indoor, unconditioned spaces, (no heat transfer to conditioned space)	0%	1.0
Location not specified - Commercial	23%	0.77
Location not specified – Industrial	16%	0.84
Custom	Custom	1 – assumed regain

$L_{sp}$  = Length of straight pipe to be insulated (linear foot)

$L_{oc,i}$  = Total equivalent length of (elbows and tees) of pipe to be insulated. Use table below to determine equivalent lengths.

Nominal Pipe Diameter	Equivalent Length (ft)	
	90 Degree Elbow	Straight Tee
1/2"	0.04	0.03
3/4"	0.06	0.05

<sup>780</sup> Katrakis, J. and T.S. Zawacki. "Field-Measured Seasonal Efficiency of Intermediate-sized Low-Pressure Steam Boilers". ASHRAE V99, pt. 2, 1993.

<sup>781</sup> Zimmerman, Cliff, Franklin Energy, "Thermal Regain Factor\_4-30-14.docx", 2014. Based on climate zone 2. Note 'Location not specified – Commercial' assumes semi-conditioned spaces with 50% pipes providing space heating and 50% providing DHW. 'Location not specified – Commercial' assumes semi-conditioned annual usage.

The table below shows the deemed therm savings by building type and region on a per linear foot basis for both ½” and ¾” copper pipe.

The following table provides deemed values for 1/2" copper pipe, temperatures are assumed by category below, and insulation is assumed to be one inch fiberglass.

Piping Use	Building Type	Annual Therms Saved / Linear Foot				
		Zone 1 (Rockford)	Zone 2 (Chicago)	Zone 3 (Springfield)	Zone 4 (Belleville)	Zone 5 (Marion)
Space Heating - Non-recirculating	Assembly	0.117	0.120	0.107	0.071	0.109
	Assisted Living	0.110	0.107	0.094	0.069	0.083
	College	0.100	0.093	0.083	0.046	0.055
	Convenience Store	0.097	0.089	0.079	0.057	0.064
	Elementary School	0.116	0.113	0.100	0.069	0.084
	Garage	0.064	0.063	0.056	0.044	0.049
	Grocery	0.105	0.105	0.092	0.057	0.068
	Healthcare Clinic	0.103	0.106	0.092	0.063	0.066
	High School	0.120	0.121	0.109	0.077	0.091
	Hospital - CAV no econ	0.115	0.119	0.101	0.087	0.099
	Hospital - CAV econ	0.117	0.121	0.103	0.089	0.101
	Hospital - VAV econ	0.048	0.045	0.034	0.020	0.022
	Hospital - FCU	0.087	0.099	0.080	0.094	0.127
	Hotel/Motel	0.115	0.112	0.101	0.069	0.084
	Hotel/Motel - Common	0.104	0.106	0.101	0.082	0.086
	Hotel/Motel - Guest	0.115	0.111	0.099	0.066	0.082
	Manufacturing Facility	0.068	0.066	0.061	0.037	0.041
	MF - High Rise	0.100	0.098	0.090	0.076	0.076
	MF - High Rise - Common	0.118	0.115	0.103	0.071	0.092
	MF - High Rise - Residential	0.096	0.096	0.087	0.075	0.073
	MF - Mid Rise	0.109	0.110	0.095	0.070	0.079
	Movie Theater	0.119	0.117	0.109	0.083	0.099
	Office - High Rise - CAV no econ	0.132	0.134	0.122	0.082	0.089
	Office - High Rise - CAV econ	0.136	0.139	0.128	0.088	0.097
	Office - High Rise - VAV econ	0.100	0.102	0.084	0.050	0.055
	Office - High Rise - FCU	0.073	0.072	0.062	0.033	0.035
	Office - Low Rise	0.093	0.093	0.074	0.045	0.052
	Office - Mid Rise	0.103	0.104	0.088	0.056	0.062
	Religious Building	0.105	0.098	0.094	0.069	0.079
	Restaurant	0.088	0.088	0.079	0.060	0.071
Retail - Department Store	0.091	0.083	0.078	0.051	0.058	
Retail - Strip Mall	0.087	0.081	0.071	0.049	0.053	
Warehouse	0.095	0.089	0.091	0.057	0.070	
Unknown	0.101	0.100	0.089	0.064	0.074	
Space Heating - recirculation heating season only	All buildings (Hours below 55°F)	0.329	0.324	0.293	0.262	0.271
Space Heating -	All buildings (All hours)	0.572	0.572	0.572	0.572	0.572

Piping Use	Building Type	Annual Therms Saved / Linear Foot				
		Zone 1 (Rockford)	Zone 2 (Chicago)	Zone 3 (Springfield)	Zone 4 (Belleville)	Zone 5 (Marion)
recirculation year round						
DHW	Recirculation loop	0.572	0.572	0.572	0.572	0.572
Process	Custom	Custom				

The following table provides deemed savings values for 3/4" copper pipe with temperatures assumed by category below, insulation is assumed to be one inch fiberglass.

Piping Use	Building Type	Annual Therms Saved / Linear Foot				
		Zone 1 (Rockford)	Zone 2 (Chicago)	Zone 3 (Springfield)	Zone 4 (Belleville)	Zone 5 (Marion)
Space Heating Non-recirculating	Assembly	0.142	0.145	0.129	0.086	0.132
	Assisted Living	0.133	0.130	0.115	0.084	0.101
	College	0.121	0.113	0.101	0.056	0.067
	Convenience Store	0.117	0.108	0.096	0.069	0.077
	Elementary School	0.141	0.137	0.121	0.084	0.102
	Garage	0.078	0.077	0.067	0.054	0.060
	Grocery	0.127	0.127	0.111	0.069	0.083
	Healthcare Clinic	0.125	0.128	0.112	0.076	0.081
	High School	0.146	0.147	0.132	0.094	0.110
	Hospital - CAV no econ	0.140	0.144	0.123	0.105	0.120
	Hospital - CAV econ	0.142	0.147	0.125	0.108	0.123
	Hospital - VAV econ	0.058	0.055	0.041	0.025	0.027
	Hospital - FCU	0.105	0.120	0.098	0.115	0.154
	Hotel/Motel	0.140	0.136	0.122	0.084	0.102
	Hotel/Motel - Common	0.127	0.129	0.123	0.100	0.105
	Hotel/Motel - Guest	0.139	0.135	0.120	0.081	0.099
	Manufacturing Facility	0.083	0.080	0.074	0.045	0.050
	MF - High Rise	0.121	0.119	0.109	0.093	0.093
	MF - High Rise - Common	0.144	0.140	0.125	0.086	0.111
	MF - High Rise - Residential	0.117	0.116	0.105	0.091	0.089
	MF - Mid Rise	0.132	0.134	0.115	0.085	0.096
	Movie Theater	0.144	0.142	0.133	0.101	0.120
	Office - High Rise - CAV no econ	0.160	0.162	0.148	0.099	0.108
	Office - High Rise - CAV econ	0.165	0.169	0.155	0.107	0.118
	Office - High Rise - VAV econ	0.121	0.123	0.102	0.060	0.067
	Office - High Rise - FCU	0.089	0.087	0.075	0.040	0.042
	Office - Low Rise	0.113	0.113	0.090	0.055	0.063
	Office - Mid Rise	0.126	0.126	0.106	0.068	0.075
	Religious Building	0.127	0.119	0.114	0.084	0.095
	Restaurant	0.107	0.107	0.096	0.073	0.086
	Retail - Department Store	0.110	0.101	0.095	0.062	0.071
	Retail - Strip Mall	0.106	0.098	0.086	0.059	0.064
Warehouse	0.115	0.108	0.111	0.069	0.085	
Unknown	0.123	0.122	0.108	0.078	0.090	
Space Heating - recirculation	All buildings (Hours below 55°F)	0.399	0.393	0.356	0.319	0.329

Piping Use	Building Type	Annual Therms Saved / Linear Foot				
		Zone 1 (Rockford)	Zone 2 (Chicago)	Zone 3 (Springfield)	Zone 4 (Belleville)	Zone 5 (Marion)
heating season only						
Space Heating - recirculation year round	All buildings (All hours)	0.694	0.694	0.694	0.694	0.694
DHW	Recirculation loop	0.694	0.694	0.694	0.694	0.694
Process	Custom	Custom				

**WATER IMPACT DESCRIPTIONS AND CALCULATION**

N/A

**DEEMED O&M COST ADJUSTMENT CALCULATION**

N/A

**MEASURE CODE: CI-HVC-SPIN-V04-240101**

**REVIEW DEADLINE: 1/1/2027**



#### 4.4.25 Small Commercial Programmable Thermostat Adjustments – Retired 12/31/2019.

## 4.4.26 Variable Speed Drives for HVAC Supply and Return Fans

### DESCRIPTION

This measure is applied to variable speed drives (VSD) which are installed on HVAC supply fans and return fans. The VSD will modulate the speed of the motor when it does not need to run at full load. Since the power of the motor is proportional to the cube of the speed for these types of applications, significant energy savings will result.

Note this measure should be used for evaluating control system modifications. If combined with the evaluation of a more efficient over a baseline fan, measure '4.4.53 HVAC Supply, Return and Exhaust Fans – Fan Energy Index' should be utilized. The FEPnew value from measure 4.4.53 should be used to replace the  $\left(0.746 \times HP \times \frac{LF}{\eta_{motor}}\right)$  term in this measure.

This measure was developed to be applicable to the following program types: TOS, RF. If applied to other program types, the measure savings should be verified.

### DEFINITION OF EFFICIENT EQUIPMENT

The VSD is applied to a motor which does not have a VSD. The application must have a variable load and installation is to include the necessary controls. Savings are based on application of VSDs to a range of baseline load conditions including no control, inlet guide vanes, outlet guide vanes and throttling valves.

### DEFINITION OF BASELINE EQUIPMENT

The time of sale baseline is a new motor installed without a VSD or other methods of control. Retrofit baseline is an existing motor operating as is. Retrofit baselines may or may not include guide vanes, throttling valves or other methods of control. This information shall be collected from the customer.

Installations of new equipment with VSDs which are required by IECC, state energy code as adopted by the State of Illinois are not eligible for incentives. As code requirements and adoption can differ from municipality to municipality, the user should verify which version of code is applicable given these constraints.

Note, IECC 2021 is expected to become effective statewide in 2023. IECC 2018 is the requisite code for any projects with permitting dates spanning July 1, 2019 to the IECC 2021 effective date. Prior to July 1, 2019, IECC 2015 is the applicable code.

### DEEMED LIFETIME OF EFFICIENT EQUIPMENT

The expected measure life for all VSDs is 15 years.<sup>782</sup>

### DEEMED MEASURE COST

Customer provided costs will be used when available. Default measure costs are noted below for up to 75 hp motors.<sup>783</sup> Custom costs must be gathered from the customer for motor sizes not listed below.

HP	Cost
5 HP	\$ 2,250
15 HP	\$ 3,318
25 HP	\$ 4,386
50 HP	\$ 6,573
75 HP	\$ 8,532

### LOADSHAPE

Loadshape C39 - VFD - Supply fans <10 HP

<sup>782</sup> Efficiency Vermont TRM 10/26/11 for HVAC VSD motors.

<sup>783</sup> NEEP Incremental Cost Study Phase Two Final Report dated January 13, 2013.

Loadshape C40 - VFD - Return fans <10 HP

Loadshape C41 - VFD - Exhaust fans <10 HP

### COINCIDENCE FACTOR

The demand savings factor (DSF) is already based upon coincident savings, and thus there is no additional coincidence factor for this characterization.

---



---

### Algorithm

---



---

#### CALCULATION OF SAVINGS

##### ELECTRIC ENERGY SAVINGS<sup>784</sup>

Note this measure should be used for evaluating control system modifications. If combined with the evaluation of a more efficient over a baseline fan, measure '4.4.53 HVAC Supply, Return and Exhaust Fans – Fan Energy Index' should be utilized. The FEP<sub>new</sub> value from measure 4.4.53 should be used to replace the  $\left(0.746 \times HP \times \frac{LF}{\eta_{motor}}\right)$  term in this measure.

$$kWh_{Base} = \left(0.746 \times HP \times \frac{LF}{\eta_{motor}}\right) \times RHRS_{Base} \times \sum_{0\%}^{100\%} (\%FF \times PLR_{Base})$$

$$kWh_{Retrofit} = \left(0.746 \times HP \times \frac{LF}{\eta_{motor}}\right) \times RHRS_{base} \times \sum_{0\%}^{100\%} (\%FF \times PLR_{Retrofit})$$

$$\Delta kWh_{fan} = kWh_{Base} - kWh_{Retrofit}$$

$$\Delta kWh_{total} = \Delta kWh_{fan} \times (1 + IE_{energy})$$

Where:

$kWh_{Base}$	= Baseline annual energy consumption (kWh/yr)
$kWh_{Retrofit}$	= Retrofit annual energy consumption (kWh/yr)
$\Delta kWh_{fan}$	= Fan-only annual energy savings
$\Delta kWh_{total}$	= Total project annual energy savings
0.746	= Conversion factor for HP to kWh
HP	= Nominal horsepower of controlled motor
LF	= Load Factor; Motor Load at Fan Design CFM (Default = 65%) <sup>785</sup>
$\eta_{motor}$	= Installed nominal/nameplate motor efficiency
	Default motor is a NEMA Premium Efficiency, ODP, 4-pole/1800 RPM fan motor

<sup>784</sup> Methodology developed and tested in Del Balso, Ryan Joseph. "Investigation into the Reliability of Energy Efficiency/Demand Side Management Savings Estimates for Variable Frequency Drives in Commercial Applications". A project report submitted to the Faculty of the Graduate School of the University of Colorado, 2013.

<sup>785</sup> Lawrence Berkeley National Laboratory, and Resource Dynamics Corporation. (2008). "Improving Motor and Drive System Performance; A Sourcebook for Industry". U.S. Department of Energy, Office of Energy Efficiency and Renewable Energy. Golden, CO: National Renewable Energy Laboratory.

**NEMA Premium Efficiency Motors Default Efficiencies<sup>786</sup>**

Size HP	Open Drip Proof (ODP)			Totally Enclosed Fan-Cooled (TEFC)		
	# of Poles			# of Poles		
	6	4	2	6	4	2
	Speed (RPM)			Speed (RPM)		
	1200	1800 Default	3600	1200	1800	3600
1	0.825	0.855	0.770	0.825	0.855	0.770
1.5	0.865	0.865	0.840	0.875	0.865	0.840
2	0.875	0.865	0.855	0.885	0.865	0.855
3	0.885	0.895	0.855	0.895	0.895	0.865
5	0.895	0.895	0.865	0.895	0.895	0.885
7.5	0.902	0.910	0.885	0.910	0.917	0.895
10	0.917	0.917	0.895	0.910	0.917	0.902
15	0.917	0.930	0.902	0.917	0.924	0.910
20	0.924	0.930	0.910	0.917	0.930	0.910
25	0.930	0.936	0.917	0.930	0.936	0.917
30	0.936	0.941	0.917	0.930	0.936	0.917
40	0.941	0.941	0.924	0.941	0.941	0.924
50	0.941	0.945	0.930	0.941	0.945	0.930
60	0.945	0.950	0.936	0.945	0.950	0.936
75	0.945	0.950	0.936	0.945	0.954	0.936
100	0.950	0.954	0.936	0.950	0.954	0.941
125	0.950	0.954	0.941	0.950	0.954	0.950
150	0.954	0.958	0.941	0.958	0.958	0.950
200	0.954	0.958	0.950	0.958	0.962	0.954
250	0.954	0.958	0.950	0.958	0.962	0.958
300	0.954	0.958	0.954	0.958	0.962	0.958
350	0.954	0.958	0.954	0.958	0.962	0.958
400	0.958	0.958	0.958	0.958	0.962	0.958
450	0.962	0.962	0.958	0.958	0.962	0.958
500	0.962	0.962	0.958	0.958	0.962	0.958

$RHRS_{Base}$  = Annual operating hours for fan motor based on building type

Default hours are provided for HVAC applications which vary by HVAC application and building type.<sup>787</sup> When available (provided via Energy Management Software or metered), actual hours should be used.

Building Type	Total Fan Run Hours	Model Source
Assembly	7235	eQuest
Assisted Living	8760	eQuest
Auto Dealership	7451	OpenStudio
College	4836	OpenStudio

<sup>786</sup> Douglass, J. (2005). Induction Motor Efficiency Standards. Washington State University and the Northwest Energy Efficiency Alliance, Extension Energy Program, Olympia, WA, October 2005.

<sup>787</sup> Hours per year are estimated using the eQuest or OpenStudio models as the total number of hours the fans are operating for heating, cooling and ventilation for each building type.

Building Type	Total Fan Run Hours	Model Source
Convenience Store	7004	eQuest
Drug Store	7156	OpenStudio
Elementary School	3765	OpenStudio
Emergency Services	8760	OpenStudio
Garage	7357	eQuest
Grocery	8543	OpenStudio
Healthcare Clinic	4314	OpenStudio
High School	3460	OpenStudio
Hospital - VAV econ	4666	OpenStudio
Hospital - CAV econ	8021	OpenStudio
Hospital - CAV no econ	7924	OpenStudio
Hospital - FCU	4055	OpenStudio
Manufacturing Facility	8706	eQuest
MF - High Rise	8760	OpenStudio
MF - Mid Rise	8760	OpenStudio
Hotel/Motel - Guest	2409	OpenStudio
Hotel/Motel - Common	8683	OpenStudio
Movie Theater	7505	eQuest
Office - High Rise - VAV econ	2369	OpenStudio
Office - High Rise - CAV econ	2279	OpenStudio
Office - High Rise - CAV no econ	5303	OpenStudio
Office - High Rise - FCU	1648	OpenStudio
Office - Low Rise	6345	OpenStudio
Office - Mid Rise	3440	OpenStudio
Religious Building	7380	eQuest
Restaurant	7302	OpenStudio
Retail - Department Store	7155	OpenStudio
Retail - Strip Mall	6921	OpenStudio
Warehouse	6832	OpenStudio
Unknown	6241	n/a

**%FF** = Percentage of run-time spent within a given flow fraction range

Default Fan Duty Cycle Based on 2012 ASHRAE Handbook; HVAC Systems and Equipment, page 45.11, Figure 12.

Flow Fraction (% of design cfm)	Percent of Time at Flow Fraction
0% to 10%	0.0%
10% to 20%	1.0%
20% to 30%	5.5%
30% to 40%	15.5%
40% to 50%	22.0%
50% to 60%	25.0%
60% to 70%	19.0%
70% to 80%	8.5%
80% to 90%	3.0%
90% to 100%	0.5%

$PLR_{Base}$  = Part load ratio for a given flow fraction range based on the baseline flow control type

$PLR_{Retrofit}$  = Part load ratio for a given flow fraction range based on the retrofit flow control type

Control Type	Flow Fraction									
	10%	20%	30%	40%	50%	60%	70%	80%	90%	100%
No Control or Bypass Damper	1.00	1.00	1.00	1.00	1.00	1.00	1.00	1.00	1.00	1.00
Discharge Dampers	0.46	0.55	0.63	0.70	0.77	0.83	0.88	0.93	0.97	1.00
Outlet Damper, BI & Airfoil Fans	0.53	0.53	0.57	0.64	0.72	0.80	0.89	0.96	1.02	1.05
Inlet Damper Box	0.56	0.60	0.62	0.64	0.66	0.69	0.74	0.81	0.92	1.07
Inlet Guide Vane, BI & Airfoil Fans	0.53	0.56	0.57	0.59	0.60	0.62	0.67	0.74	0.85	1.00
Inlet Vane Dampers	0.38	0.40	0.42	0.44	0.48	0.53	0.60	0.70	0.83	0.99
Outlet Damper, FC Fans	0.22	0.26	0.30	0.37	0.45	0.54	0.65	0.77	0.91	1.06
Eddy Current Drives	0.17	0.20	0.25	0.32	0.41	0.51	0.63	0.76	0.90	1.04
Inlet Guide Vane, FC Fans	0.21	0.22	0.23	0.26	0.31	0.39	0.49	0.63	0.81	1.04
VFD with duct static pressure controls	0.09	0.10	0.11	0.15	0.20	0.29	0.41	0.57	0.76	1.01
VFD with low/no duct static pressure	0.05	0.06	0.09	0.12	0.18	0.27	0.39	0.55	0.75	1.00

Provided below is the resultant values based upon the defaults provided above:

Control Type	$\sum_{0\%}^{100\%} (\%FF \times PLR_{Base})$
No Control or Bypass Damper	1.00
Discharge Dampers	0.80
Outlet Damper, BI & Airfoil Fans	0.78
Inlet Damper Box	0.69
Inlet Guide Vane, BI & Airfoil Fans	0.63
Inlet Vane Dampers	0.53
Outlet Damper, FC Fans	0.53
Eddy Current Drives	0.49
Inlet Guide Vane, FC Fans	0.39
VFD with duct static pressure controls	0.30
VFD with low/no duct static pressure	0.27

$IE_{energy}$  = HVAC interactive effects factor for energy (default = 15.7%)

**SUMMER COINCIDENT PEAK DEMAND SAVINGS**

$$kW_{Base} = \left( 0.746 \times HP \times \frac{LF}{\eta_{motor}} \right) \times PLR_{Base,FFpeak}$$

$$kW_{Retrofit} = \left( 0.746 \times HP \times \frac{LF}{\eta_{motor}} \right) \times PLR_{Retrofit,FFpeak}$$

$$\Delta kW_{fan} = kW_{Base} - kW_{Retrofit}$$

$$\Delta kW_{total} = \Delta kW_{fan} \times (1 + IE_{demand})$$

Where:

$kW_{Base}$  = Baseline summer coincident peak demand (kW)

$kW_{Retrofit}$	= Retrofit summer coincident peak demand (kW)
$\Delta kW_{fan}$	= Fan-only summer coincident peak demand impact
$\Delta kW_{total}$	= Total project summer coincident peak demand impact
$PLR_{Base,FFpeak}$	= The part load ratio for the average flow fraction between the peak daytime hours during the weekday peak time period based on the baseline flow control type (default average flow fraction during peak period = 90%)
$PLR_{Retrofit,FFpeak}$	= The part load ratio for the average flow fraction between the peak daytime hours during the weekday peak time period based on the retrofit flow control type (default average flow fraction during peak period = 90%)
$IE_{demand}$	= HVAC interactive effects factor for summer coincident peak demand (default = 15.7%)

**FOSSIL FUEL IMPACT DESCRIPTIONS AND CALCULATION**

There are no expected fossil fuel impacts for this measure.

**WATER IMPACT DESCRIPTIONS AND CALCULATION**

N/A

**DEEMED O&M COST ADJUSTMENT CALCULATION**

N/A

**MEASURE CODE: CI-HVC-VSDF-V09-240101**

**REVIEW DEADLINE: 1/1/2026**

## 4.4.27 Energy Recovery Ventilator

### DESCRIPTION

This measure includes the addition of energy recovery equipment on existing or new unitary equipment, where energy recovery is not required by the IECC 2012/2015/2018/2021. This measure analyzes the heating and cooling savings potential from recovering energy from exhaust or relief building air. This measure assumes that during unoccupied hours of the building no exhaust or relief air is available for energy recovery.

This measure was developed to be applicable to the following program types: TOS, NC, RF.

If applied to other program types, the measure savings should be verified.

### DEFINITION OF EFFICIENT EQUIPMENT

Efficient equipment is unitary equipment that incorporates energy recovery not required by the IECC 2012/2015/2018/2021.

### DEFINITION OF BASELINE EQUIPMENT

The baseline is unitary equipment not required by IECC 2012/2015/2018/2021 to incorporate energy recovery.

Note, IECC 2021 is expected to become effective statewide in 2023. IECC 2018 is the requisite code for any projects with permitting dates spanning July 1, 2019 to the IECC 2021 effective date. Prior to July 1, 2019, IECC 2015 is the applicable code. As code requirements and adoption can differ from municipality to municipality, the user should verify which version of code is applicable given these constraints.

### DEEMED LIFETIME OF EFFICIENT EQUIPMENT

The measure life for the domestic energy recovery equipment is 15 years.<sup>788</sup>

### DEEMED MEASURE COST

The incremental cost for this measure assumes cost of cabinet and controls incorporated into packaged and built up air handler units. Additionally, it assumes a 1 to 1 ratio of fresh and exhausted air.

Energy Recovery Equipment Type	Incremental Cost \$/CFM <sup>789</sup>
Plate Heat Exchanger	\$3.75
Rotary Wheel	\$3.75
Heat Pipe	\$3.75

### DEEMED O&M COST ADJUSTMENTS

There are no expected O&M savings associated with this measure.

### LOADSHAPE

N/A

### COINCIDENCE FACTOR

N/A

---

<sup>788</sup> Assumed service life limited by controls - "Demand Control Ventilation Using CO<sub>2</sub> Sensors", pg. 19, by US Department of Energy Efficiency and Renewable Energy.

<sup>789</sup> "National Cost-Effectiveness of ASHRAE Standard 90.1-2010 Compared to ASHRAE Standard 90.1-2007", PNNL, November 2007 (page 4-16).



**Algorithm**

**CALCULATION OF ENERGY SAVINGS ELECTRIC ENERGY SAVINGS**

The electric energy savings calculation here represents the net electric energy savings from reduced cooling requirements after accounting for increased fan power caused by additional pressure drop from the ERV device. These savings do not account for heating energy savings in HVAC systems using heat pumps or electric resistance heat. This calculation does not apply to wheel-type devices with purge sections, or to sensible-only devices such as heat pipes.

$$\Delta kWh = (cfm) * \text{Normalized Electric Energy Savings}$$

cfm = design supply air flow of energy recovery ventilator in cubic feet per minute  
 = rated energy recovery ventilator supply air flow \* (1 – Exhaust Air Transfer Ratio)

Exhaust Air Transfer Ratio = percentage of supply air made up of cross-leakage from exhaust air; value provided by vendor  
 = 0.05 (default)

Normalized Electric Energy Savings  
 = kWh/cfm savings value for the expected energy savings (net of fan energy penalty) as detailed in Table 1 – Electric Energy Savings Summary (kWh/cfm)

**Table 1 – Electric Energy Savings Summary (kWh/cfm)<sup>790</sup>**

Building Type	Normalized Electricity Savings (kWh/OA cfm)				
	Zone 1 - Rockford	Zone 2 - Chicago	Zone 3 - Springfield	Zone 4 - Mt. Vernon/Belleville	Zone 5 - Marion
<b>Enthalpy Wheel - 75% sensible and latent effectiveness</b>					
Assembly	NA	NA	NA	0.107	0.229
Education	NA	NA	0.371	0.245	0.369
Grocery	NA	NA	0.239	0.523	0.630
Healthcare	1.551	1.594	2.508	2.999	3.077
Multifamily	2.178	2.566	3.781	4.746	5.029
Office	0.974	1.169	2.379	2.998	3.194
Retail	0.048	0.124	0.389	1.027	1.063
<b>Enthalpy Plate - 50% sensible and latent effectiveness</b>					
Assembly	NA	NA	NA	NA	NA
Education	NA	NA	NA	NA	0.035
Grocery	NA	NA	NA	0.002	0.102
Healthcare	0.923	0.963	1.548	1.841	1.908
Multifamily	0.627	0.908	1.450	2.341	2.509
Office	0.309	0.487	1.321	1.705	1.918
Retail	NA	NA	NA	0.398	0.435

**SUMMER COINCIDENT PEAK DEMAND SAVINGS**

$$\Delta kW = (cfm) * \text{Normalized Electric Peak Demand Savings} * CF$$

= design supply air flow of energy recovery ventilator in cubic feet per minute

<sup>790</sup> Energy savings modeled using IL TRM energy models with added energy recovery wheels or enthalpy plates. Energy recovery device specifications based on product data from the AHRI Certification Directory (<https://www.ahridirectory.org/Search/SearchHome?ReturnUrl=%2f>). See reference “ERV Effectiveness AHRI Directory Survey.”

= rated energy recovery ventilator supply air flow \* (1 – Exhaust Air Transfer Ratio)

Exhaust Air Transfer Ratio = percentage of supply air made up of cross-leakage from exhaust air; value provided by vendor

= 0.05 (default)

CF = 1.0

Normalized Electric Peak Demand Savings

= kW/cfm savings value for the appropriate combination of building type, climate zone, and measure scenario per Table 2 – Electric Peak Demand Savings Summary (kW/cfm)

**Table 2 – Electric Peak Demand Savings Summary (kW/cfm)<sup>791</sup>**

Building Type	Normalized Electric Demand Savings (kW/OA cfm)				
	Zone 1 - Rockford	Zone 2 - Chicago	Zone 3 - Springfield	Zone 4 - Mt. Vernon/Belleville	Zone 5 - Marion
<b>Enthalpy Wheel - 75% sensible and latent efficiency</b>					
Assembly	0.00127	0.00092	0.00111	0.00213	0.00209
Education	0.00159	0.00164	0.00282	0.00202	0.00308
Grocery	0.00115	0.00159	0.00152	0.00153	0.00187
Healthcare	0.00465	0.00433	0.00480	0.00443	0.00443
Multifamily	0.00210	0.00325	0.00298	0.00370	0.00381
Office	0.00538	0.00518	0.00527	0.00529	0.00589
Retail	0.00156	0.00195	0.00020	0.00217	0.00223
<b>Enthalpy Plate - 50% sensible and latent efficiency</b>					
Assembly	NA	NA	0.00024	0.00115	0.00113
Education	0.00114	0.00118	0.00201	0.00142	0.00218
Grocery	0.00059	0.00089	0.00083	0.00079	0.00102
Healthcare	0.00287	0.00284	0.00306	0.00292	0.00275
Multifamily	NA	0.00128	0.00111	0.00172	0.00167
Office	0.00351	0.00344	0.00344	0.00345	0.00384
Retail	0.00087	0.00123	0.00001	0.00119	0.00124

**FOSSIL FUEL SAVINGS**

Gas savings algorithm is derived from the following:

$$\Delta\text{Therms} = (\text{Design Heating Load} * \text{TE\_ERV} * \text{EFLH} * \text{OccHours}/24) / (100,000 * \eta_{\text{Heat}})$$

Where:

Design Heating Load = (1.08 \* CFM \* ΔT)

1.08 = A constant for sensible heat equations (BTU/h/CFM.°F)

CFM = Cubic Feet per Minute of Energy Recovery Ventilator

ΔT = T\_RA – T\_DD

T\_RA = Temperature of the Return Air = 70°F or custom

<sup>791</sup> Demand savings modeled using IL TRM energy models with added energy recovery wheels or enthalpy plates. Energy recovery device specifications based on product data from the AHRI Certification Directory (<https://www.ahridirectory.org/Search/SearchHome?ReturnUrl=%2f>). Coincident demand measured according to TRM guidelines, though in 1-hour increments as established by the eQUEST simulation.

T\_DD = Temperature on design day of outside air<sup>792</sup>  
 = (see Table below) or custom

Zone	Weather Station	T_DD, Temperature, °F
1	Greater Rockford	-5.4
2	Chicago/O’Hare ARPT.	-1.0
3	Springfield/Capital	1.1
4	Scott AFB MidAmerica	7.2
5	Cape Girardeau Regional	10.1
Average	-	2.4

TE\_ERV = Thermal Effectiveness of Energy Recovery Equipment<sup>793</sup>  
 = (see Table below) or custom

Heat Recovery Equipment Type	TE_ERV (%)
Fixed Plate	0.65
Rotary Equipment	0.68
Heat Pipe	0.55

EFLH = Equivalent Full Load Hours for heating in Existing Buildings or New Construction are provided in section 4.4 HVAC End Use

OccHours = Average Hours per day facility is occupied  
 = custom or use Modeling Inputs in eQuest models:

Building Type	Weekday	Saturday	Sunday	Holiday	Annual Operating Hours	OccHours
Assembly/Convention Center	10am-9pm	10am-9pm	10am-9pm	closed	3905	10.7
Assisted Living	24/7	24/7	24/7	24/7	8760	24.0
College	8am-9pm	closed	closed	closed	3263	8.9
Convenience Store	7am-10pm	9am-9pm	10am-5pm	10am-5pm	4823	13.2
Elementary School	8am-4pm (20% in summer)	closed	closed	closed	1606	4.4
Garage	7am-5pm	8am-12pm	closed	closed	3342	9.1
Grocery	7am-9pm	7am-9pm	9am-8pm	closed	4814	13.2
Healthcare Clinic	7am-7pm	9am-5pm	closed	closed	3428	9.4
High School	8am-4pm (20% in summer)	closed	closed	closed	1606	4.4
Hospital	24/7	24/7	24/7	24/7	8760	24.0
Motel	24/7	24/7	24/7	24/7	8760	24.0
Manufacturing Facility (Light Industry)	Mfg: 6am-10pm, Office: 8am-5pm	Mfg: 6am-10pm, Office: closed	closed	closed	4848	13.3
Multi-Family Mid-Rise	24/7; Reduced occupancy 7am - 5pm	24/7; Reduced occupancy 9am - 3pm	24/7; Reduced occupancy 9am - 3pm	24/7; Reduced occupancy 9am - 3pm	7038	19.3

<sup>792</sup>Weather Station Data, 99.6% Heating DB - 2021 Fundamentals, ASHRAE Handbook. The following weather stations were referenced: Climate Zone 1: Chicago Rockford Int’l, Climate Zone 2: Chicago O’Hare Int’l, Climate Zone 3: Abraham Lincoln Capital, Climate Zone 4: Scott AFB, Climate Zone 5: Cape Girardeau Regional.

<sup>793</sup>Energy Recovery Fact Sheet - Center Point Energy, MN

Building Type	Weekday	Saturday	Sunday	Holiday	Annual Operating Hours	OccHours
Multi-Family High-Rise	24/7; Reduced occupancy 7am - 5pm	24/7; Reduced occupancy 9am - 3pm	24/7; Reduced occupancy 9am - 3pm	24/7; Reduced occupancy 9am - 3pm	7038	19.3
Movie Theater	10am-Midnight	10am-Midnight	10am-Midnight	10am-Midnight	5110	14.0
Office - Low-rise	8am-5pm	closed	closed	closed	2259	6.2
Office - Mid-rise	8am-5pm	20% 8am-noon	closed	closed	2301	6.3
Office - High-rise	8am-5pm	20% 8am-noon	closed	closed	2301	6.3
Religious Building	Office: 8am-5pm, other: closed	closed	8am-1pm	closed	260	0.7
Restaurant	7am-8pm	7am-8pm	7am-8pm	closed	4615	12.6
Retail - Department Store	9am-9pm	9am-9pm	10am-5pm	10am-5pm	4070	11.1
Retail - Strip Mall	9am-9pm	9am-9pm	10am-5pm	10am-5pm	4070	11.1
Warehouse (Conditioned Storage)	7am-7pm	7am-7pm (reduced occupancy)	closed	closed	3324	9.1

$\eta_{Heat}$  = Efficiency of heating system  
 = Actual

**WATER IMPACT DESCRIPTIONS AND CALCULATION**

N/A

**DEEMED O&M COST ADJUSTMENT CALCULATION**

N/A

**MEASURE CODE: CI-HVC-ERVE-V06-240101**

**REVIEW DEADLINE: 1/1/2026**

## 4.4.28 Stack Economizer for Boilers Serving HVAC Loads

### MEASURE DESCRIPTION

Stack economizers are designed to recover heat from hot boiler flue gasses. Recovered heat is used to preheat boiler feed water. This measure describes the retrofit of HVAC boilers with stack economizers. HVAC boilers are defined as those used for space heating applications. There is another, similar measure for boilers that serve process loads.

This measure was developed to be applicable to the following program types: NC, TOS, RF.

If applied to other program types, the measure savings should be verified.

### DEFINITION OF EFFICIENT EQUIPMENT

To qualify the economizer must be installed on a boiler exhaust stack. Heat captured by the economizer is to be used to pre-heat boiler feed water.

### DEFINITION OF BASELINE EQUIPMENT

The baseline boiler does not have an economizer installed.

### DEEMED LIFETIME OF EFFICIENT EQUIPMENT

The measure life for the boiler stack economizer is 15 years.<sup>794</sup>

### DEEMED MEASURE COST

The incremental and full measure cost for this measure is custom.

### DEEMED O&M COST ADJUSTMENTS

The O&M cost for this measure is custom.

### LOADSHAPE

N/A

### COINCIDENCE FACTOR

N/A

---

---

### Algorithm

---

---

### CALCULATION OF ENERGY SAVINGS

#### ELECTRIC ENERGY SAVINGS

N/A

#### SUMMER COINCIDENT PEAK DEMAND SAVINGS

N/A

#### FOSSIL FUEL SAVINGS

$$\Delta\text{therms} = \text{SF} * \text{MBH}_{\text{In}} * \text{EFLH} / 100$$

Where:

---

<sup>794</sup> PA Consulting, Focus on Energy Evaluation, Business Programs: Measure Life Study, August 25, 2009.

SF = Savings factor  
 = calculated custom as  $(T_{\text{existing}} - T_{\text{eff}}) / 40^{\circ}\text{F} * \text{TRE}$  or when not possible a default value based on the table below

Where:

$T_{\text{existing}}$  = Existing Full Fire Boiler Flue Gas Temperature as it exits the Stack<sup>795</sup>  
 = 425°F (water, 81.9% eff) or custom  
 = 480°F (steam, 80.7% eff) or custom

$T_{\text{eff}}$  = Efficient Full Fire Boiler Flue Gas Temperature as it exits the Stack  
 = 338°F (conventional economizer – Water Boiler)<sup>796</sup> or custom  
 = 365°F (conventional economizer – Steam Boiler)<sup>797</sup> or custom  
 = 280°F (condensing economizer – Water Boiler)<sup>798</sup> or custom  
 = 308°F (condensing economizer – Steam Boiler)<sup>799</sup> or custom

TRE = % efficiency increase for 40°F of stack temperature reduction  
 = 1%,<sup>800</sup> or custom

Based on defaults provided above:

Boiler Type	SF <sup>801</sup>	
	Conventional Economizer	Condensing Economizer
Hot Water Boiler	2.19% average SF or custom	3.63% average SF or custom
Steam Boiler	2.88% average SF or custom	4.31% average SF or custom

MBH<sub>In</sub> = Rated boiler input capacity, in MBH  
 = Actual

EFLH = Equivalent Full Load Hours for heating are provided in Section 4.4 HVAC End Use

<sup>795</sup> Cleaver Brooks. March 2012, Boiler Efficiency Guide, Pg. 7, Figure 1.

<sup>796</sup> The minimum stack temperature for a non-condensing economizer is 250°F from Department of Energy (DOE). January 2012, Steam Tip Sheet #26A, Consider Installing a Condensing Economizer. Advanced Manufacturing Office. Washington, DC: U.S. Department of Energy. The average temperature drop is assumed to be ½ way between the existing and efficient temperature minimum,  $(425^{\circ}\text{F} + 250^{\circ}\text{F}) / 2 = 338^{\circ}\text{F}$ .

<sup>797</sup> The minimum stack temperature for a non-condensing economizer is 250°F from Department of Energy (DOE). January 2012, Steam Tip Sheet #26A, Consider Installing a Condensing Economizer. Advanced Manufacturing Office. Washington, DC: U.S. Department of Energy. The average temperature drop is assumed to be ½ way between the existing and efficient temperature minimum,  $(480^{\circ}\text{F} + 250^{\circ}\text{F}) / 2 = 365^{\circ}\text{F}$ .

<sup>798</sup> The minimum stack temperature for a condensing economizer is 250°F from Department of Energy (DOE). January 2012, Steam Tip Sheet #26A, Consider Installing a Condensing Economizer. Advanced Manufacturing Office. Washington, DC: U.S. Department of Energy. The average temperature drop is assumed to be ½ way between the existing and efficient temperature minimum,  $(425^{\circ}\text{F} + 135^{\circ}\text{F}) / 2 = 280^{\circ}\text{F}$ .

<sup>799</sup> The minimum stack temperature for a condensing economizer is 250°F from Department of Energy (DOE). January 2012, Steam Tip Sheet #26A, Consider Installing a Condensing Economizer. Advanced Manufacturing Office. Washington, DC: U.S. Department of Energy. The average temperature drop is assumed to be ½ way between the existing and efficient temperature minimum,  $(480^{\circ}\text{F} + 135^{\circ}\text{F}) / 2 = 308^{\circ}\text{F}$ .

<sup>800</sup> United States EPA, Climate Wise: Wise Rules for Industrial Efficiency, July 1998. The Wise Rules indicate savings range of 1-2% per 40°F reduction, so utilizing 1% is a conservative approach.

<sup>801</sup> These average values should be utilized in absence of actual temperature data. An economizer with a zero temperature change between the existing and the efficient temperatures would not be installed, so these average values are conservative.

**WATER IMPACT DESCRIPTIONS AND CALCULATION**

N/A

**DEEMED O&M COST ADJUSTMENT CALCULATION**

Depending on design, stack economizers may require routine maintenance for optimal performance. A custom calculation should be used as necessary.

**MEASURE CODE: CI-HVC-BECO-V02-210101**

**REVIEW DEADLINE: 1/1/2025**

## 4.4.29 Stack Economizer for Boilers Serving Process Loads

### MEASURE DESCRIPTION

Stack economizers are designed to recover heat from hot boiler flue gasses. Recovered heat is used to preheat boiler feed water. This measure describes the retrofit of process boilers with stack economizers. Process boilers are defined as those used for industrial, manufacturing, or other non-HVAC applications. There is another, similar measure for boilers that serve HVAC loads.

This measure was developed to be applicable to the following program types: NC, TOS, RF.

If applied to other program types, the measure savings should be verified.

### DEFINITION OF EFFICIENT EQUIPMENT

To qualify the economizer must be installed on a boiler exhaust stack. Heat captured by the economizer is to be used to pre-heat boiler feed water.

### DEFINITION OF BASELINE EQUIPMENT

The baseline boiler does not have an economizer installed.

### DEEMED LIFETIME OF EFFICIENT EQUIPMENT

The measure life for the boiler stack economizer is 15 years.<sup>802</sup>

### DEEMED MEASURE COST

The incremental and full measure cost for this measure is custom.

### DEEMED O&M COST ADJUSTMENTS

The O&M cost for this measure is custom.

### LOADSHAPE

N/A

### COINCIDENCE FACTOR

N/A

---

### Algorithm

---

### CALCULATION OF ENERGY SAVINGS

#### ELECTRIC ENERGY SAVINGS

N/A

#### SUMMER COINCIDENT PEAK DEMAND SAVINGS

N/A

#### FOSSIL FUEL SAVINGS

$$\Delta \text{therms} = \text{SF} * \text{MBH}_{\text{In}} * 8766 * \text{UF} / 100$$

---

<sup>802</sup> PA Consulting, Focus on Energy Evaluation, Business Programs: Measure Life Study, August 25, 2009.



Where:

- SF =  $(T_{\text{existing}} - T_{\text{eff}}) / 40^{\circ}\text{F} * \text{TRE}$   
 = see default Savings Factor table below
- T\_existing = Existing Full Fire Boiler Flue Gas Temperature as it exits the Stack<sup>803</sup>  
 = 425°F (water, 81.9% eff per IL TRM) or custom  
 = 480°F (steam, 80.7% eff per IL TRM) or custom
- T\_eff = Efficient Full Fire Boiler Flue Gas Temperature as it exits the Stack  
 = 338°F (conventional economizer – Water Boiler)<sup>804</sup> or custom  
 = 365°F (conventional economizer – Steam Boiler)<sup>805</sup> or custom  
 = 280°F (condensing economizer – Water Boiler)<sup>806</sup> or custom  
 = 308°F (condensing economizer – Water Boiler)<sup>807</sup> or custom
- TRE = % efficiency increase for 40°F of stack temperature reduction  
 = 1%,<sup>808</sup> or custom

Based on defaults provided above:

Boiler Type	SF <sup>809</sup>	
	Conventional Economizer	Condensing Economizer
Hot Water Boiler	2.19% average SF or custom	3.63% average SF or custom
Steam Boiler	2.88% average SF or custom	4.31% average SF or custom

- MBH\_In = Rated boiler input capacity, in MBH  
 = Actual
- 8766 = Hours a year
- UF = Utilization Factor

<sup>803</sup> Cleaver Brooks. March 2012, Boiler Efficiency Guide, Pg. 7, Figure 1.

<sup>804</sup> The minimum stack temperature for a non-condensing economizer is 250°F from Department of Energy (DOE). January 2012, Steam Tip Sheet #26A, Consider Installing a Condensing Economizer. Advanced Manufacturing Office. Washington, DC: U.S. Department of Energy. The average temperature drop is assumed to be ½ way between the existing and efficient temperature minimum,  $(425^{\circ}\text{F} + 250^{\circ}\text{F}) / 2 = 338^{\circ}\text{F}$ .

<sup>805</sup> The minimum stack temperature for a non-condensing economizer is 250°F from Department of Energy (DOE). January 2012, Steam Tip Sheet #26A, Consider Installing a Condensing Economizer. Advanced Manufacturing Office. Washington, DC: U.S. Department of Energy. The average temperature drop is assumed to be ½ way between the existing and efficient temperature minimum,  $(480^{\circ}\text{F} + 250^{\circ}\text{F}) / 2 = 365^{\circ}\text{F}$ .

<sup>806</sup> The minimum stack temperature for a condensing economizer is 250°F from Department of Energy (DOE). January 2012, Steam Tip Sheet #26A, Consider Installing a Condensing Economizer. Advanced Manufacturing Office. Washington, DC: U.S. Department of Energy. The average temperature drop is assumed to be ½ way between the existing and efficient temperature minimum,  $(425^{\circ}\text{F} + 135^{\circ}\text{F}) / 2 = 280^{\circ}\text{F}$ .

<sup>807</sup> The minimum stack temperature for a condensing economizer is 250°F from Department of Energy (DOE). January 2012, Steam Tip Sheet #26A, Consider Installing a Condensing Economizer. Advanced Manufacturing Office. Washington, DC: U.S. Department of Energy. The average temperature drop is assumed to be ½ way between the existing and efficient temperature minimum,  $(480^{\circ}\text{F} + 135^{\circ}\text{F}) / 2 = 308^{\circ}\text{F}$ .

<sup>808</sup> United States EPA, Climate Wise: Wise Rules for Industrial Efficiency, July 1998. The Wise Rules indicate savings range of 1-2% per 40°F reduction, so utilizing 1% is a conservative approach.

<sup>809</sup> These average values should be utilized in absence of actual temperature data. An economizer with a zero temperature change between the existing and the efficient temperatures would not be installed, so these average values are conservative.

= 41.9%,<sup>810</sup> or custom

**WATER IMPACT DESCRIPTIONS AND CALCULATION**

N/A

**DEEMED O&M COST ADJUSTMENT CALCULATION**

N/A

**MEASURE CODE: CI-HVC-PECO-V02-220101**

**REVIEW DEADLINE: 1/1/2026**

---

<sup>810</sup> Work Paper – Tune up for Boilers serving Space Heating and Process Load by Resource Solutions Group, January 2012

### 4.4.30 Notched V Belts for HVAC Systems

#### MEASURE DESCRIPTION

This measure is for replacement of smooth v-belts in non-residential package and split HVAC systems with notched v-belts or for installing new equipment with synchronous belts instead of smooth v-belts. Typically there is a v-belt between the motor and the supply air fan and/or return air fan in larger package and split HVAC systems (RTU).

In general there are two styles of grooved v-belts, notched and synchronous. The DOE defines each as follows;

**Notched V-Belts** - A notched belt has grooves or notches that run perpendicular to the belt's length, which reduces the bending resistance of the belt. Notched belts can use the same pulleys as cross-section standard V-belts. They run cooler, last longer, and are about 2% more efficient than standard V-belts.

**Synchronous Belts** - Synchronous belts (also called cogged, timing, positive-drive, or high-torque drive belts) are toothed and require the installation of mating grooved sprockets. These belts operate with a consistent efficiency of 98% and maintain their efficiency over a wide load range.

- Smooth v-belts are usually referred to in five basic groups:
- "L" belts are low end belts that are for small, fractional horsepower motors and these are not used in RTUs.
- "A" and "B" belts are the two types typically used in RTUs. The "A" belt is a ½ inch width by 5/16 inch thickness and the "B" belt is larger, 21/32 inch wide and 12/32 inch thick so it can carry more power. V-belts come in a wide variety of lengths where 20 to 100 inches is typical.
- "C" and "D" belts are primarily for industrial applications with high power transmission requirements.
- V-belts are provided by various vendors. The notched version of these belts typically have an "X" added to the designation. For this HVAC fans notched v-belt Replacement measure, only the "A" and "B" v-belts are considered. A typical "A" v-belt is replaced by a notched "AX" v-belt and a "B" is replaced by a "BX." In general, smooth v-belts have an efficiency of 90% to 98% while notched v-belts have an efficiency of 95% to 98%. Because notched v-belts are more flexible they work with smaller diameter pulleys and they have less resistance to bending. Lower bending resistance increases the power transmission efficiency, lowers the waste heat, and allows the belt to last longer than a smooth belt.

Three research papers<sup>811 812 813</sup> show that the notched v-belt efficiency is 2% to 5% better than a typical smooth v-belt. A fourth paper by USDOE's Energy Efficiency and Renewable Energy<sup>814</sup> group reviewed most of the earlier literature and recommended using a conservative 2% efficiency improvement for energy savings for calculations.

For this measure it is assumed that upgrading a standard smooth v-belt with a new notched v-belt will result in a fan energy reduction of 2%.

#### DEFINITION OF EFFICIENT EQUIPMENT

For the Notched V-Belt characterization to apply, the Efficient Equipment is HVAC RTUs that have notched v-belts installed on the supply and/or return air fans. This can be done as a retrofit, TOS, or NC project.

For the Synchronous Belt characterization to apply, the Efficient Equipment is HVAC RTUs that have synchronous belts installed on the supply and/or return air fans. This can be done as a TOS or NC project. Retrofit projects can also claim savings, but costs should be verified independently (typically the cost of installing synchronous belts as a retrofit is not economically viable).

<sup>811</sup> "Gates Corporation Announces New EPDM Molded Notch V-Belts," The Gates Rubber Co., June 2010 (Assumed 3% efficiency improvement).

<sup>812</sup> "Synchronous Belt Drives Offer Low Cost Energy Savings," Baldor. February 2009. (attached in Reference Documents).

<sup>813</sup> "Energy Savings from Synchronous Belts," The Gates Rubber Co., February 2014. (Assumed 5% efficiency improvement).

<sup>814</sup> "Motor System Tip Sheet #5, Replace V-Belts with Cogged or Synchronous Belt Drives," USDOE-EERE, September 2005. (Assumed 2% efficiency improvement).

**DEFINITION OF BASELINE EQUIPMENT**

The Baseline Equipment is HVAC RTUs that have smooth v-belts installed on the supply and/or return air fans (i.e., RTU does not already have a notched v-belt installed).

**DEEMED LIFETIME OF EFFICIENT EQUIPMENT**

A v-belt has a life based on fan run hours which varies by building type based primarily on occupancy schedule because the fans are required by code to operate continuously during occupied hours. The supply and return fans will also run a few hours during unoccupied hours for heating and cooling as needed. For the notched v-belt EUL calculation, the default hours in the following table are used for a variety of building types and HVAC applications.<sup>815</sup>

$$EUL = \text{Belt Life} / \text{Occupancy Hours per year}$$

Where:

$$\text{Belt Life} = 24,000 \text{ hours}^{816}$$

$$\text{Occupancy Hours per year} = \text{values from Table below}$$

The notched v-belt measure EUL is summarized by building type in the following table.

**Notched v-belt Effective Useful Life (EUL)**

Building Type	Total Fan Run Hours	EUL (Years)	Model Source
Assembly	7235	3.3	eQuest
Assisted Living	8760	2.7	eQuest
Auto Dealership	7451	3.2	OpenStudio
College	4836	5.0	OpenStudio
Convenience Store	7004	3.4	eQuest
Drug Store	7156	3.4	OpenStudio
Elementary School	3765	6.4	OpenStudio
Emergency Services	8760	2.7	OpenStudio
Garage	7357	3.3	eQuest
Grocery	8543	2.8	OpenStudio
Healthcare Clinic	4314	5.6	OpenStudio
High School	3460	6.9	OpenStudio
Hospital - VAV econ	4666	5.1	OpenStudio
Hospital - CAV econ	8021	3.0	OpenStudio
Hospital - CAV no econ	7924	3.0	OpenStudio
Hospital - FCU	4055	5.9	OpenStudio
Manufacturing Facility	8706	2.8	eQuest
MF - High Rise	8760	2.7	OpenStudio
MF - Mid Rise	8760	2.7	OpenStudio
Hotel/Motel - Guest	2409	10.0	OpenStudio
Hotel/Motel - Common	8683	2.8	OpenStudio
Movie Theater	7505	3.2	eQuest
Office - High Rise - VAV econ	2369	10.1	OpenStudio
Office - High Rise - CAV econ	2279	10.5	OpenStudio
Office - High Rise - CAV no econ	5303	4.5	OpenStudio

<sup>815</sup> ComEd Trm June 1, 2010 page 139. The Office hours is based upon occupancy from the eQuest model developed for EFLH, since it was agreed the ComEd value was too low.

<sup>816</sup> "DEER2014-EUL-table-update\_2014-02-05.xlsx," Database for Energy Efficiency Resources (DEER), DEER2014 EUL Table. (attached in Reference Documents).

Building Type	Total Fan Run Hours	EUL (Years)	Model Source
Office - High Rise - FCU	1648	14.6	OpenStudio
Office - Low Rise	6345	3.8	OpenStudio
Office - Mid Rise	3440	7.0	OpenStudio
Religious Building	7380	3.3	eQuest
Restaurant	7302	3.3	OpenStudio
Retail - Department Store	7155	3.4	OpenStudio
Retail - Strip Mall	6921	3.5	OpenStudio
Warehouse	6832	3.5	OpenStudio
Unknown	6241	3.8	n/a

The lifetime of a synchronous belt system is the same as the lifetime of the equipment it is installed on because it is a permanent upgrade, involving the installation of toothed pulleys. Typical HVAC RTU lifetime is 15 years, which applies to synchronous belts as well. This is not to suggest that the actual belt component has an equivalent lifetime because they do require replacement. However, their O&M cost savings (derived from not having to tension, etc.) are assumed to offset the replacement cost of the belt, resulting in a net cost of zero. As a result, neither a separate lifetime nor O&M savings are quantified for synchronous belts and lifetime can therefore be considered as the lifetime of the equipment they’re installed on because it would not be possible to install a traditional or notched belt on the synchronous pulleys.

**DEEMED MEASURE COST**

Costs of belts and pulleys are known to vary substantially based on belt length and pulley diameter. Two cost estimations are provided below; a fully deemed approach for applications such as an upstream program where limited information is known, and a semi-custom approach that is useful when more accurate cost estimates are desired.

Fully Deemed:

A review of the Grainger online pricing for “A,” “B,” “AX,” and “BX” v-belts<sup>817</sup> revealed the incremental costs to upgrade to notched v-belts as summarized in the table below:

**Notched V-belt Incremental Cost Summary**

Smooth V-Belt Industry Number	Outside Length (Inches)	Dayton Smooth V-Belt*	Notched V-belt Industry Number	Dayton Notched v-belt*	Price Increase	% Increase
A30 (Item # 1A095)	32	\$10.38	AX30 (Item # 3GWU4)	\$14.64	\$4.26	41%
B29 (Item # 6L208)	32	\$14.38	BX29 (Item # 5TXL4)	\$20.80	\$6.42	45%

\* Pricing based on Dayton Belts as found on Grainger Website 10/30/14

Note that the incremental cost for notched V-Belts assumes that the notched belt is purchased and installed instead of a smooth v-belt. There is no difference in the cost of installation, only the material.

**Synchronous Belt Incremental Cost Summary**

Smooth V-Belt Industry Number	Smooth belt system Price*	Synchronous Belt Industry Number	Synchronous System Price*	Price Difference
Belt A30 (Item # 1A095)	\$10.38	Belt 1DHL5 (Item # 322L050)	\$15.37	\$4.99

<sup>817</sup> Grainger catalog on-line web-site for Dayton v-belt pricing.

Smooth V-Belt Industry Number	Smooth belt system Price*	Synchronous Belt Industry Number	Synchronous System Price*	Price Difference
Gearbelt pulley BK47 (Item #5UHD5)	\$47.98	Gearbelt sprocket GTR-36G-8M-12 (Item # 2UWH6)	\$113.91	\$65.93
* Costs based on Grainger pricing.				

Incremental cost for a NC or TOS project is \$136.85. This is the price of synchronous equipment (belt, two sprockets) subtract v-belt equipment (belt, two pulleys). Labor cost is assumed to be equal in the baseline and efficient cases.

Incremental cost for a RF project is \$380.49. This is the price of synchronous equipment and labor to install it<sup>818</sup> (not including a trip charge), less the cost of the v-belt (but not the pulleys).

Semi-Custom<sup>819</sup>

Use the following relationships along with NC, TOS and RF assumptions outlined above to estimate semi-custom costs.

Component	Type	Cost Function (per inch)	Inch Measurement
Standard V-Belt	A	\$0.28/in + \$0.96	Outside Length
Standard V-Belt	B	\$0.29/in + \$9.15	Outside Length
Standard Pulley	A, B, AX, BX	\$11.85/in - \$9.47	Outside Diameter
Notched Belt	AX	\$0.36/in + \$1.07	Outside Length
Notched Belt	BX	\$0.49/in + \$2.33	Outside Length
Synchronous Belt	1/2 inch	\$0.58/in + \$8.90	Pitch Length
Synchronous Belt	1 inch	\$0.26/in + \$5.67	Pitch Length
Synchronous Pulley	for use with 1/2 inch belt	\$27.20/in - \$21.19	Pitch Diameter
Synchronous Pulley	for use with 1 inch belt	\$25.04/in - \$27.23	Pitch Diameter

**DEEMED O&M COST ADJUSTMENTS**

N/A

**LOADSHAPE**

Loadshape C05 - Commercial Electric Heating and Cooling

**COINCIDENCE FACTOR**

N/A

---

**Algorithm**

---

<sup>818</sup> Assumed to be \$150 based on mechanical contractor estimate.

<sup>819</sup> Based on review and trend fitting cost data from Grainger online. See reference document “Notched V Belts costs.xlsx” for derivation.

**CALCULATION OF ENERGY SAVINGS**

**ELECTRIC ENERGY SAVINGS**

$$\Delta kWh = kW_{connected} * Hours * ESF$$

Where:

$kW_{Connected}$  =kW of equipment is calculated using motor efficiency<sup>820</sup>

$$= (HP * 0.746 kW/HP * Load Factor) / Motor Efficiency$$

Load Factor =Motors are assumed to have a load factor of 80% for calculating KW if actual values cannot be determined.<sup>821</sup> Custom load factor may be applied if known.

Motor Efficiency = Actual motor efficiency shall be used to calculate KW. If not known a value from the motor efficiency reference tables below should be used.<sup>822</sup> Default motor is a NEMA Premium Efficiency, ODP, 4-pole/1800 RPM fan motor.

Baseline Motor Efficiencies (EPACT)						
Size HP	Open Drip Proof (ODP)			Totally Enclosed Fan-Cooled (TEFC)		
	# of Poles					
	6	4	2	6	4	2
	Speed (RPM)					
	1200	1800	3600	1200	1800	3600
1/8	-	44.00%	-	-	-	-
1/6	57.50%	62.00%	-	-	-	-
1/4	68.00%	68.00%	-	68.00%	64.00%	-
1/3	70.00%	70.00%	72.00%	70.00%	68.00%	72.00%
1/2	78.50%	80.00%	68.00%	72.00%	74.00%	68.00%
3/4	77.00%	78.50%	74.00%	77.00%	75.50%	74.00%
1	80.00%	82.50%	75.50%	80.00%	82.50%	75.50%
1.5	84.00%	84.00%	82.50%	85.50%	84.00%	82.50%
2	85.50%	84.00%	84.00%	86.50%	84.00%	84.00%
3	86.50%	86.50%	84.00%	87.50%	87.50%	85.50%
5	87.50%	87.50%	85.50%	87.50%	87.50%	87.50%
7.5	88.50%	88.50%	87.50%	89.50%	89.50%	88.50%
10	90.20%	89.50%	88.50%	89.50%	89.50%	89.50%
15	90.20%	91.00%	89.50%	90.20%	91.00%	90.20%
20	91.00%	91.00%	90.20%	90.20%	91.00%	90.20%
25	91.70%	91.70%	91.00%	91.70%	92.40%	91.00%

Efficient Motor Efficiencies (NEMA Premium)						
Size HP	Open Drip Proof (ODP)			Totally Enclosed Fan-Cooled (TEFC)		
	# of Poles					
	2	4	6	2	4	6
	Speed (RPM)					

<sup>820</sup> Note that kW<sub>Connected</sub> may be determined using various methodologies. The examples provided use rated HP and assumed load factor. Other methodologies include rated voltage and full load current with assumed load factor, or actual measured voltage and current.

<sup>821</sup> Com Ed TRM June 1, 2010.

<sup>822</sup> Efficiency values for motors less than one HP taken from Baldor Electric Catalog 501, standard motor product catalog.

Efficient Motor Efficiencies (NEMA Premium)						
	1200	1800 (Default)	3600	1200	1800	3600
0.125 *	-	44.00%	-	-	-	-
1/6	57.50%	62.00%	-	-	-	-
1/4	68.00%	68.00%	-	68.00%	64.00%	-
1/3	70.00%	70.00%	72.00%	70.00%	68.00%	72.00%
1/2	78.50%	80.00%	68.00%	72.00%	74.00%	68.00%
3/4	77.00%	78.50%	74.00%	77.00%	75.50%	74.00%
1	82.50%	85.50%	77.00%	82.50%	85.50%	77.00%
1.5	86.50%	86.50%	84.00%	87.50%	86.50%	84.00%
2	87.50%	86.50%	85.50%	88.50%	86.50%	85.50%
3	88.50%	89.50%	85.50%	89.50%	89.50%	86.50%
5	89.50%	89.50%	86.50%	89.50%	89.50%	88.50%
7.5	90.20%	91.00%	88.50%	91.00%	91.70%	89.50%
10	91.70%	91.70%	89.50%	91.00%	91.70%	90.20%
15	91.70%	93.00%	90.20%	91.70%	92.40%	91.00%
20	92.40%	93.00%	91.00%	91.70%	93.00%	91.00%
25	93.00%	93.60%	91.70%	93.00%	93.60%	91.70%

Hours = When available, actual hours should be used. If actual hours are not available, default hours are provided in table below for HVAC fan operation<sup>823</sup>, which varies by building type:

Building Type	Total Fan Run Hours	Model Source
Assembly	7235	eQuest
Assisted Living	8760	eQuest
Auto Dealership	7451	OpenStudio
College	4836	OpenStudio
Convenience Store	7004	eQuest
Drug Store	7156	OpenStudio
Elementary School	3765	OpenStudio
Emergency Services	8760	OpenStudio
Garage	7357	eQuest
Grocery	8543	OpenStudio
Healthcare Clinic	4314	OpenStudio
High School	3460	OpenStudio
Hospital - VAV econ	4666	OpenStudio
Hospital - CAV econ	8021	OpenStudio
Hospital - CAV no econ	7924	OpenStudio
Hospital - FCU	4055	OpenStudio
Manufacturing Facility	8706	eQuest
MF - High Rise	8760	OpenStudio
MF - Mid Rise	8760	OpenStudio
Hotel/Motel - Guest	2409	OpenStudio
Hotel/Motel - Common	8683	OpenStudio

<sup>823</sup> Hours per year are estimated using the eQuest models as the total number of hours the fans are operating for heating, cooling and ventilation for each building type.



Building Type	Total Fan Run Hours	Model Source
Movie Theater	7505	eQuest
Office - High Rise - VAV econ	2369	OpenStudio
Office - High Rise - CAV econ	2279	OpenStudio
Office - High Rise - CAV no econ	5303	OpenStudio
Office - High Rise - FCU	1648	OpenStudio
Office - Low Rise	6345	OpenStudio
Office - Mid Rise	3440	OpenStudio
Religious Building	7380	eQuest
Restaurant	7302	OpenStudio
Retail - Department Store	7155	OpenStudio
Retail - Strip Mall	6921	OpenStudio
Warehouse	6832	OpenStudio
Unknown	6241	n/a

ESF = Energy Savings Factor, the ESF for notched v-belt Installation is assumed to be 2%  
 = the ESF for notched Synchronous Belt Installation is assumed to be 3.1%<sup>824</sup>

**For example**, a notched v-belt installation in an low rise office building RTU with a 5 HP NEMA premium efficiency motor using the default hours of operation, motor load and 89.5% motor efficiency;

$$\begin{aligned} \Delta kWh &= kW_{\text{connected}} * \text{Hours} * \text{ESF} \\ &= ((\text{HP} * 0.746 \text{ kW/HP} * \text{Load Factor}) / \text{Motor Efficiency}) * \text{Hours} * \text{ESF} \\ &= ((5 \text{ HP} * 0.746 \text{ kW/HP} * 80\%) / 89.5\%) * 6288 * 2\% \\ &= 419 \text{ kWh Savings} \end{aligned}$$

**SUMMER COINCIDENT PEAK DEMAND SAVINGS**

$$\Delta kW = kW_{\text{connected}} * \text{ESF} * \text{CF}$$

Where:

$kW_{\text{Connected}}$  = kW of equipment is calculated using motor efficiency.  
 =  $(\text{HP} * 0.746 \text{ kW/HP} * \text{Load Factor}) / \text{Motor Efficiency}$

$CF_{\text{SSP}}$  = Summer System Peak Coincidence Factor for Commercial cooling (during system peak hour)  
 = 91.3%<sup>825</sup>

$CF_{\text{PJM}}$  = PJM Summer Peak Coincidence Factor for Commercial cooling (average during peak period)  
 = 47.8%<sup>826</sup>

Variables as provided above

<sup>824</sup> Based on information found in Advanced Manufacturing Office, US DOE, “Replace V-Belts with Notched or Synchronous Drives”, (US Department of Energy Motor Systems Tip Sheet #5, DOE/GO-102012-3740, November 2012). V-belt drives can have a peak efficiency of 95% and synchronous belts operate at 98%, therefore ESF is  $(1-95\%/98\%) = 3.1\%$ .

<sup>825</sup> Based on analysis of Itron eShape data for Missouri, calibrated to Illinois loads, supplied by Ameren. The AC load during the utility’s peak hour is divided by the maximum AC load during the year.

<sup>826</sup> Based on analysis of Itron eShape data for Missouri, calibrated to Illinois loads, supplied by Ameren. The average AC load over the PJM peak period (1-5pm, M-F, June through August) is divided by the maximum AC load during the year.

**For example**, an office building RTU with a 5 HP NEMA premium efficiency motor using the default motor load and 89.5% motor efficiency;

$$\begin{aligned}\Delta kW_{SSP} &= kW_{connected} * ESF * CF \\ &= ((HP * 0.746 \text{ kW/HP} * \text{Load Factor}) / \text{Motor Efficiency}) * ESF * CF \\ &= ((5 \text{ HP} * 0.746 \text{ kW/HP} * 80\%) / 89.5\%) * 2\% * 0.913 \\ &= 0.0609 \text{ kW Savings}\end{aligned}$$

**FOSSIL FUEL SAVINGS**

N/A

**WATER IMPACT DESCRIPTIONS AND CALCULATION**

N/A

**DEEMED O&M COST ADJUSTMENT CALCULATION**

N/A

**MEASURE CODE: CI-HVC-NVBE-V06-210101**

**REVIEW DEADLINE: 1/1/2026**

### 4.4.31 Small Business Furnace and Rooftop Unit Tune-Up

#### DESCRIPTION

This measure is for a fossil fuel Small Business furnace or Gas-Fired Rooftop Unit that provides space heating. The tune-up will improve furnace or gas-fired rooftop unit performance by inspecting, cleaning, and adjusting the furnace or rooftop unit and appurtenances for correct and efficient operation. Additional savings may be realized through a complete system tune-up.

This measure was developed to be applicable to the following program types: RF (small businesses).

If applied to other program types, the measure savings should be verified.

#### DEFINITION OF EFFICIENT EQUIPMENT

To qualify for this measure an approved technician must complete the tune-up requirements listed below:<sup>827</sup>

- Measure combustion efficiency using an electronic flue gas analyzer
- Check and clean blower assembly and components per manufacturer’s recommendations
- Where applicable lubricate motor and inspect and replace fan belt, if required
- Inspect for gas leaks
- Clean burner per manufacturer’s recommendations and adjust as needed
- Check ignition system and safety systems and clean and adjust as needed
- Check and clean heat exchanger per manufacturer’s recommendations
- Inspect exhaust/flue for proper attachment and operation
- Inspect control box, wiring and controls for proper connections and performance
- Check air filter and clean or replace per manufacturer’s recommendations
- Inspect duct work connected to furnace for leaks or blockages
- Measure temperature rise and adjust flow as needed
- Check for correct line and load volts/amps
- Check thermostat operation is per manufacturer’s recommendations (if adjustments made, refer to ‘Small Commercial Programmable Thermostat Adjustment’ measure for savings estimate)
- Perform Carbon Monoxide test and adjust heating system until results are within standard industry acceptable limits

#### DEFINITION OF BASELINE EQUIPMENT

The baseline equipment is a furnace or a gas-fired rooftop unit assumed not to have had a tune-up in the past 3 years.

#### DEEMED LIFETIME OF EFFICIENT EQUIPMENT

The measure life for the tune up is 3 years.<sup>828</sup>

#### DEEMED MEASURE COST

The incremental cost for this measure should be the actual invoiced cost of the tune-up.

---

<sup>827</sup> American Standard Heating & Air Conditioning, Maintenance for Indoor Units

<sup>828</sup> Assumed consistent with other tune-up measures. For more detail, see: 4.4.1 Air Conditioner Tune-Up (3 years is given for “Clean Condenser Coils – Commercial” and “Clean Evaporator Coils”. DEER2014 EUL Table.) and 4.4.2 Space Heating Boiler Tune-Up (Act on Energy Commercial Technical Reference Manual No. 2010-4, 9.2.2 Gas Boiler Tune-up.)

**DEEMED O&M COST ADJUSTMENTS**

There are no expected O&M savings associated with this measure.

**LOADSHAPE**

Loadshape C04 - Commercial Electric Heating

**COINCIDENCE FACTOR**

N/A

**Algorithms**

**CALCULATION OF ENERGY SAVINGS**

**ELECTRIC ENERGY SAVINGS**

$$\Delta\text{kWh} = \Delta\text{Therms} * F_e * 29.3$$

Where:

$$\Delta\text{Therms} = \text{as calculated below}$$

$$F_e = \text{Furnace or rooftop fan energy consumption as a percentage of annual fuel consumption}$$

$$= 7.7\%^{829}$$

$$29.3 = \text{kWh per therm}$$

**SUMMER COINCIDENT PEAK DEMAND SAVINGS**

N/A

**FOSSIL FUEL SAVINGS**

$$\Delta\text{Therms} = (\text{Capacity} * \text{EFLH} * (((\text{Eff}_{\text{before}} + E_i) / \text{Eff}_{\text{before}}) - 1)) / 100,000$$

Where:

$$\text{Capacity} = \text{Furnace gas input size (Btu/hr)}$$

$$= \text{Actual}$$

$$\text{EFLH} = \text{Equivalent Full Load Hours for heating in Existing Buildings are provided in section 4.4 HVAC End Use}$$

$$\text{Eff}_{\text{before}} = \text{Efficiency of the furnace before the tune-up}$$

$$= \text{Actual}$$

*Note: Contractors should select a mid-level firing rate that appropriately represents the average building operating condition over the course of the heating season and take readings at a consistent firing rate for pre and post tune-up.*

$$E_i = \text{Efficiency Improvement of the furnace tune-up measure}$$

$$= \text{Actual}$$

<sup>829</sup>  $F_e$  is estimated using TRM models for the three most popular building types for programmable thermostats: low-rise office (10.2%), sit-down restaurant (8.6%), and retail – strip mall (4.4%). 7.7% reflects the average  $F_e$  of the three building types. See “Fan Energy Factor Example Calculation 2021-06-23.xlsx” for reference.

100,000 = Converts Btu to therms

**For example**, a 200 kBtu furnace in a Rockford low rise office records an efficiency prior to tune up of 82% AFUE and a 1.8% improvement in efficiency are tune up:

$$\begin{aligned}\Delta\text{therms} &= (200,000 * 1428 * (((0.82 + 0.018)/ 0.82) - 1)) / 100,000 \\ &= 62.3 \text{ therms}\end{aligned}$$

**WATER IMPACT DESCRIPTIONS AND CALCULATION**

N/A

**DEEMED O&M COST ADJUSTMENT CALCULATION**

N/A

**O&M COST ADJUSTMENT CALCULATION**

N/A

**MEASURE CODE: CI-HVC-FTUN-V05-230101**

**REVIEW DEADLINE: 1/1/2028**

## 4.4.32 Combined Heat and Power

### DESCRIPTION

During 2021 and 2022, a TAC CHP Working Group held multiple discussions with a view to updating this measure. While some progress was made, including moving towards a more custom approach, a difference in policy interpretation relating to the appropriate calculation of gas savings, and the appropriate data for determining emission rates over the lifetime of the measure, has prevented reaching consensus. Discussions will continue in 2023 and if required a non-consensus exhibit will be completed and filed in order that the Commission can provide a ruling on the appropriate methodology. Until then, the existing version of this measure is maintained.

The Combined Heat and Power (CHP) measure can provide energy savings within the State of Illinois through the development and operation of CHP projects. This measure is applicable for Conventional or Topping Cycle CHP systems, as well as Waste Heat-to-Power (WHP) or Bottoming Cycle CHP systems. The measure will reduce the total Btu's of energy required to meet the end use needs of the facility.

It is recognized that CHP system design and configuration may be complex, and as such the calculation of energy savings may not be reducible to the equations within this measure. In such cases a more comprehensive engineering and financial analysis may be developed that more accurately incorporates the attributes of complex CHP configurations such as variable-capacity systems, and partial combined-cycle CHP systems. Where noted, the use of values that are determined through an external engineering analysis may be substituted by agreement between the participant, the program administrator and independent evaluator. This substitution of values does not eliminate ex post evaluation risk (retroactive adjustments to savings claims) that exists when using custom inputs.

Due to the long planning horizon for CHP projects, CHP projects will use the project permit date to determine the version of the IL-TRM the implementation teams will follow. The purpose of this is to confirm the savings calculation methodologies for projects as early as possible due to the long planning horizon for the measure.

This measure was developed to be applicable to the following program types: Retrofit (RF), New Construction (NC). If applied to other program types, the measure savings should be verified.

### DEFINITION OF EFFICIENT EQUIPMENT

Conventional or Topping Cycle CHP is defined as an integrated system that is located at or near the building or facility (on-site, on the customer side of the meter) that utilizes a prime mover (reciprocating engine, gas turbine, micro-turbine, fuel cell, boiler/steam turbine combination) for the purpose of generating electricity and useful thermal energy (such as steam, hot water, or chilled water) where the primary function of the facility where the CHP is located is not to generate electricity for use on the grid. An eligible system must demonstrate a minimum total system efficiency of 60% (HHV),<sup>830</sup> with at least 20% of the system's total useful energy output in the form of useful thermal energy on an annual basis.

*Measuring and Calculating Conventional CHP Total System Efficiency:*

CHP efficiency is calculated using the following equation:

$$CHP_{Efficiency(HHV)} = \frac{\left[ CHP_{thermal} \left( \frac{kBtu}{yr} \right) + E_{CHP} \left( \frac{kWh}{yr} \right) * 3.412 \left( \frac{kBtu}{kWh} \right) \right]}{F_{totalCHP} \left( \frac{kBtu}{yr} \right)}$$

Where:

<sup>830</sup> Higher Heating Value (HHV): refers to the heating value of the fuel and is defined as the total thermal energy available, including the heat of condensation of water vapors, resulting from complete combustion of the fuel versus the Lower Heating Value (LHV), which assumes the heat of condensation is not available.

- $CHP_{\text{thermal}}$  = Useful annual thermal energy output from the CHP system, defined as the annual thermal energy output of the CHP system that is actually recovered and utilized in the facility/process.
- $E_{\text{CHP}}$  = Useful annual electricity output produced by the CHP system, defined as the annual electric energy output of the CHP system that is actually utilized to replace purchased electricity required to meet the requirements of the facility/process.
- $F_{\text{totalCHP}}$  = Total annual fuel consumed by the CHP system

For further definition of the terms, please see “Calculation of Energy Savings” Section below.

Waste Heat-to-Power or Bottoming Cycle CHP is defined as an integrated system that is located at or near the building or facility (on-site, on the customer side of the meter) that does one of the following:

- Utilizes exhaust heat from an industrial/commercial process to generate electricity (except for exhaust heat from a facility whose primary purpose is the generation of electricity for use on the grid); or
- Utilizes the pressure drop in an industrial/commercial facility to generate electricity through a backpressure steam turbine where the facility normally uses a pressure reducing valve (PRV) to reduce the pressure in their facility; or
- Utilizes the pressure reduction in natural gas pipelines (located at natural gas compressor stations) before the gas is distributed through the pipeline to generate electricity, provided that the conversion of energy to electricity is achieved without using additional fossil fuels.

Since these types of systems utilize waste heat as their fuel, they do not have to meet any specific total system efficiency level (assuming they use no additional fossil fuel in their operation) If additional fuel is used onsite, it should be accounted for using the following methodology:

- Treat the portion of Waste-Heat-to-Power that does not require any additional fuel using the Waste-Heat-to-Power methodology outlined in this document.
- Treat the portion of Waste-Heat-to-Power that requires additional fuel (if natural gas) using the Conventional CHP methodology outlined in this document. If the additional fuel is not natural gas, custom carbon equivalency calculations would be needed – refer to section “Calculation of Energy Savings” for more details.
- Add the energy savings together.

These systems may export power to the grid.

#### **DEFINITION OF BASELINE EQUIPMENT**

Electric Baseline: The baseline facility would be a facility that purchases its electric power from the grid.

Heating Baseline (for CHP applications that displace onsite heat): The baseline equipment would be the boiler/furnace operating onsite, or a boiler/furnace meeting the baseline equipment defined in the High Efficiency Boiler (Section 4.4.10)/Furnace (Section 4.4.11) measures of this TRM.

Cooling Baseline (for CHP applications that displace onsite cooling demands): The baseline equipment would be the chiller (or chillers) operating onsite, or a chiller (or chillers) meeting the definition of baseline equipment defined in the Electric Chiller (Section 4.4.6) measure of this TRM.

Facilities that use biogas or waste gas: Facilities that use (but are not purchasing) biogas or waste gas that is not otherwise used, whether they are using biogas or waste gas only or a combination of biogas or waste gas and natural gas to meet their energy demands are also eligible for this measure. If additional fuel is purchased to power the CHP system, then the additional natural gas should be taken into account using the following methodology:

- Treat the portion of CHP system that does not require any additional fuel, or that requires additional fuel that would otherwise be wasted (e.g., flared), using the Waste-Heat-to-Power methodology outlined in this document.

- Treat the portion of CHP that requires additional fuel (if natural gas) using the Conventional CHP methodology outlined in this document. If the additional fuel is not natural gas, custom carbon equivalency calculations would be needed – refer to section “Calculation of Energy Savings” for more details.
- Add the energy savings together.

Consumption of any biogas or waste gas that would not otherwise being wasted (e.g., flared) will be accounted for in the overall net BTU savings calculations the same as for purchased natural gas.

**DEEMED LIFETIME OF EFFICIENT EQUIPMENT**

Measure life is a custom assumption, dependent on the technology selected and the system installation.

**DEEMED MEASURE COST**

Custom installation and equipment cost will be used. These costs should include the cost of the equipment and the cost of installing the equipment. Equipment costs include, but are not limited to: prime mover, heat recovery system(s), exhaust gas treatment system(s), controls, and any interconnection/electrical connection costs.

The installations costs include labor and material costs such as, but not limited to: labor costs, materials such as ductwork, piping, and wiring, project and construction management, engineering costs, commissioning costs, and other fees.

Measure costs will also include the present value of expected maintenance costs over the life of the CHP system.

**LOADSHAPE**

Use Custom Loadshape. The loadshape should be obtained from the actual CHP operation strategy, based on the On-Peak and Off-Peak Energy definitions specified in Table 3.3 of “Section 3.5 Electrical Loadshapes” of the TRM.

**COINCIDENCE FACTOR**

Custom coincidence factor will be used. Actual value based on the CHP operation strategy will be used.

---



---

**Algorithm**

---

**CALCULATION OF ENERGY SAVINGS**

**i) Conventional or Topping Cycle CHP Systems:**

**Step 1: (Calculating Total Annual Source Fuel Savings in Btus)**

The first step is to calculate the total annual source fuel savings associated with the CHP installation, in order to ensure the CHP project produces positive total annual source fuel savings (i.e., reduction in source Btus):

$$S_{\text{FuelCHP}} = \text{Annual fuel savings (Btu) associated with the use of a Conventional CHP system to generate the useful electricity output (kWh, converted to Btu) and useful thermal energy output (Btu) versus the use of the equivalent electricity generated and delivered by the local grid and the equivalent thermal energy provided by the onsite boiler/furnace.}$$

$$= (F_{\text{grid}} + F_{\text{thermalCHP}}) - F_{\text{total CHP}}$$

Where:

$$F_{\text{grid}} = \text{Annual fuel in Btu that would have been used to generate the useful electricity output of the CHP system if that useful electricity output was provided by the local utility grid.}$$

$$= E_{\text{CHP}} * H_{\text{grid}}$$

Where:



- $E_{CHP}$  = Useful annual electricity output produced by the CHP system, defined as the annual electric energy output of the CHP system that is actually utilized to replace purchased electricity required to meet the requirements of the facility/process.<sup>831</sup>
- = (  $CHP_{capacity} * Hours$  ) -  $E_{Parasitic}$
- $CHP_{capacity}$  = CHP nameplate capacity  
= Custom input
- Hours = Annual operating hours of the system  
= Custom input
- $E_{Parasitic}$  = The electricity required to operate the CHP system that would otherwise not be required by the facility/process  
= Custom input
- $H_{grid}$  = Heat rate of the grid in Btu/kWh, based on the average fossil heat rate for the EPA eGRID subregion, adjusted to take into account T&D losses.

For systems operating less than 6,500 hrs per year:

Use the Non-baseload heat rate provided by EPA eGRID for RFC West region for ComEd territory (including independent providers connected to RFC West), and SERC Midwest region for Ameren territory (including independent providers connected to SERC Midwest).<sup>832</sup> Also include any line losses.

For systems operating more than 6,500 hrs per year:

Use the All Fossil Average heat rate provided by EPA eGRID for RFC West region for ComEd territory (including independent providers connected to RFC West), and SERC Midwest region for Ameren territory (including independent providers connected to SERC Midwest). Also include any line losses.

$F_{thermalCHP}$  = Annual fuel in Btu that would have been used on-site by a boiler/furnace to provide the useful thermal energy output of the CHP system.<sup>833</sup>

=  $CHP_{thermal} / Boiler_{eff}$  (or  $CHP_{thermal} / Furnace_{eff}$ )

$CHP_{thermal}$  = Useful annual thermal energy output from the CHP system, defined as the annual thermal energy output of the CHP system that is actually recovered and utilized in the facility/process.

= Custom input

$Boiler_{eff} / Furnace_{eff}$  = Efficiency of the on-site Boiler/Furnace that is displaced by the CHP system or if unknown, the baseline equipment value stated in the High Efficiency Boiler (Section 4.4.10) measure or High Efficiency Furnace (Section 4.4.11) measure in this TRM.

= Custom input

<sup>831</sup> For complex systems this value may be obtained from a CHP System design/financial analysis study.

<sup>832</sup> These values are subject to regular updates so should be reviewed regularly to ensure the current assumptions are correct. Refer to the latest EPA eGRID data. Current values, based on eGrid 2018 are:

Non-Baseload RFC West: 10,024 Btu/kWh \* (1 + Line Losses)

Non-Baseload SERC Midwest: 9,871 Btu/kWh \* (1 + Line Losses)

All Fossil Average RFC West: 9,575 Btu/kWh \* (1 + Line Losses)

All Fossil Average SERC Midwest: 10,369 Btu/kWh \* (1 + Line Losses)

<sup>833</sup> For complex systems this value may be obtained from a CHP System design/financial analysis study.

$F_{\text{total CHP}}$  = Total fuel in Btus consumed by the CHP system  
 = Custom input

**Step 2: (Savings Allocation to Program Administrators for Purposes of Assessing Compliance with Energy Savings Goals (Not for Use in Load Reduction Forecasting))**

Savings claims are a function of the electric output of the CHP system ( $E_{\text{CHP}}$ ), the used thermal output of the CHP system ( $F_{\text{thermalCHP}}$ ), and the CHP system efficiency ( $\text{CHP}_{\text{Eff}}(\text{HHV})$ ). The percentages of electric output and used thermal output that can be claimed also differ slightly depending on whether the project was included in both electric<sup>834</sup> and gas<sup>835</sup> Energy Efficiency Portfolio Standard (EEPS)<sup>836</sup> efficiency programs, only an electric EEPS program or only a gas EEPS program. The tables below provide the specific percentages of electric and/or thermal output that can be claimed under each of those three scenarios. These percentages apply only to cases in which natural gas is the fuel used by the CHP system. Saving estimates for systems using other fuels should be calculated on a custom basis. If the waste heat recovered from the CHP system is offsetting electric equipment, such as an absorption chiller offsetting an electric chiller, then the net change in electricity consumption associated with the electric equipment should be added to the allocated electric savings.

1) For systems participating in both electric EEPS and gas EEPS programs:

CHP Annual System Efficiency (HHV)	Allocated Electric Savings	Allocated Gas Savings
<b>60%</b>	65% of $E_{\text{CHP}}$ (kWh)	No gas savings
<b>&gt;60% to 65%</b>	65% of $E_{\text{CHP}}$ (kWh) + one percentage point increase for every one percentage point increase in CHP system efficiency (max 70% of $E_{\text{CHP}}$ in kWh)	No gas Savings
<b>&gt;65%</b>	70% of $E_{\text{chp}}$ (kWh)	2.5% of $F_{\text{thermal}}$ (Boiler Natural Gas offset by CHP thermal) for every one percentage point increase in CHP system efficiency above 65%.

Example: System with measured annual system efficiency (HHV) of 70%: Electric savings (kWh) = 70% of  $E_{\text{CHP}}$  measured over 12 months, and Gas savings (therms) = 12.5% of  $F_{\text{thermal}}$  measured over 12 months (70% - 65% = 5 X 2.5% = 12.5%).

2) For systems participating in only an electric EEPS program:

CHP Annual System Efficiency (HHV)	Allocated Electric Savings	Allocated Gas Savings
<b>60%</b>	65% of $E_{\text{CHP}}$ (useful electric output of CHP system in kWh)	No gas Savings
<b>Greater than 60%</b>	65% + one percentage point increase for every one percentage point increase in CHP system efficiency (no max)	No gas Savings

Example: System with measured annual fuel use efficiency of 75%: Electric savings (kWh) = 65% + 15% = 80% of  $E_{CHP}$  measured over 12 months (15% = 1% for every 1% increase in system efficiency). No gas savings (therms).

3) For systems participating in only a gas EEPS program:

CHP Annual System Efficiency (HHV)	Allocated Electric Savings	Allocated Gas Savings
<b>60% or greater</b>	No electric savings	2.5% of $F_{thermal}$ (Boiler Natural Gas offset by CHP thermal) for every one percentage point increase in CHP system efficiency above 60%.

Example: System with measured annual system efficiency (HHV) of 70%: No Electric savings (kWh). Gas savings (therms) = 25% of  $F_{thermal}$  measured over 12 months (70% - 60% = 10 X 2.5% = 25%).

Conventional or topping cycle CHP systems virtually always require an increase in the use of fuel on-site in order to produce electricity. Different jurisdictions and experts across the country have employed and/or put forward a variety of approaches to address how increased on-site fuel consumption should be reflected in the attribution of electric savings to CHP systems.<sup>837</sup> The approach reflected in the tables above is generally consistent – for CHP systems consuming natural gas – with approaches recently put forward by the Southwest Energy Efficiency Project (SWEET) and Institute for Industrial Productivity (IIP) that determine reduced electric savings based on the equivalent amount of carbon dioxide generated from the increased fuel used.<sup>838</sup>

There are a variety of ways one could treat the potential for gas utilities to claim savings from CHP projects in their EEPS portfolios. For projects in which a natural gas EEPS program is involved, the tables above treat savings from CHP installations in two steps: (1) a fuel-switch from electricity to natural gas (i.e., using more natural gas to eliminate the need to generate as much electricity on the grid); and (2) possible increases in CHP efficiency above a “benchmark” level. When both electric EEPS and natural gas EEPS programs are involved in a project, the program administrator claims all the electricity savings associated with a fuel-switch up to a “benchmark” 65% efficient CHP system. All the savings associated with increasing CHP efficiencies above that benchmark level are allocated to natural gas (e.g., if the CHP efficiency is 75%, the natural gas savings associated with an increase in CHP efficiency from 65% to 75% are allocated to natural gas). That is consistent with the notion that CHP efficiency typically increases primarily by increasing the use of the thermal output of the system (increasing the displacement of baseline gas use). For projects that involve only a natural gas EEPS program, the “benchmark” above which the gas utility can claim savings is lowered to 60%.

ii) **Waste-Heat-to-Power CHP Systems :**

**ELECTRIC ENERGY SAVINGS:**

$$\Delta kWh = E_{CHP}$$

Where:

$E_{CHP}$  = Useful annual electricity output produced by the CHP system, defined as the annual electric energy output of the CHP system that is actually utilized to replace purchased electricity required to meet the requirements of the facility/process.

= Custom input

<sup>839</sup> If some or all of the existing electric chiller peak demand is no longer needed due to new waste heat powered chillers (e.g., absorption), the coincidence factor should be adjusted appropriately.

**SUMMER COINCIDENT PEAK DEMAND SAVINGS**

$$\Delta kW = CF * CHP_{capacity}$$

Where:

- CF = Summer Coincidence factor. This factor should also consider any displaced chiller capacity.<sup>839</sup>  
= Custom input
- CHP<sub>Capacity</sub> = CHP nameplate capacity  
= Custom input

**FOSSIL FUEL ENERGY SAVINGS:**

$$\Delta Therms = F_{thermalCHP} \div 100,000$$

Where:

- F<sub>thermalCHP</sub> = Net savings in annual purchased fuel in Btu, if any, that would have been used on-site by a boiler/furnace to provide some or all of the useful thermal energy output of the CHP system.<sup>840</sup>
- 100,000 = Conversion factor for Btu to therms

**WATER IMPACT DESCRIPTIONS AND CALCULATION**

N/A

**DEEMED O&M COST ADJUSTMENT CALCULATION**

Custom estimates of maintenance costs that will be incurred for the life of the measure will be used. Maintenance costs vary with type and size of the prime mover. These costs include, but are not limited to:

- Maintenance labor
- Engine parts and materials such as oil filters, air filters, spark plugs, gaskets, valves, piston rings, electronic components, etc. and consumables such as oil
- Minor and major overhauls

For screening purposes, the US EPA has published resource guides that provide average maintenance costs based on CHP technology and system size.<sup>841</sup>

**COST-EFFECTIVENESS SCREENING AND LOAD REDUCTION FORECASTING**

For the purposes of forecasting load reductions due to CHP projects, changes in site energy use at the customer’s meter – reduced consumption of utility provided electricity – adjusted for utility line losses (at-the-busbar savings), customer switching estimates, NTG, and any other adjustment factors deemed appropriate, should be used.

For the purposes of screening a CHP measure application for cost-effectiveness, changes in site energy use – reduced consumption of utility provided electricity and the net change in consumption of fuel – should be used. In general, the benefit and cost components used in evaluating the cost-effectiveness of a CHP project would include at least the following terms:

<sup>839</sup> If some or all of the existing electric chiller peak demand is no longer needed due to new waste heat powered chillers (e.g., absorption), the coincidence factor should be adjusted appropriately.

<sup>840</sup> In most cases, it is expected that waste-heat-to-power systems will not provide any new net useful thermal energy output, since the CHP system will be driven by thermal energy that was otherwise being wasted. If additional natural gas or other purchased energy is used onsite, it should be properly accounted for.

<sup>841</sup> “EPA Combined Heat and Power Partnership Resources” Oct 07, 2014, in the document “Catalog of CHP Technologies”, US EPA, September 2017, pages 2-16,, 3-14, 4-14, 5-14, and 6-16.

**MEASURE CODE: CI-HVC-CHAP-V07-230101**

**REVIEW DEADLINE: 1/1/2025**

### 4.4.33 Industrial Air Curtain

#### DESCRIPTION

This measure applies to buildings with exterior entryways that utilize overhead doors. All other air curtain applications, such as through sliding door entryways or conventional foot-traffic entryways, require custom analysis as air curtain designs must often accommodate other factors that may change their effectiveness.

The use of overhead doors within exterior entryways during the heating season leads to the exfiltration of warm air from the upper portion of the door opening and the infiltration of colder air from the lower portion of the door opening. This results in increase heating energy use to compensate for heat losses every time a door is opened. By reducing heat losses, air curtains can also enhance the physical comfort of employees or customers near the entryway as there will be reduced temperature fluctuations when the door is opened and closed. In addition, in some cases excess heating capacity may be installed in buildings to meet this larger heating load. The addition of air curtains to exterior entryways that currently utilize overhead doors will result in energy savings and enhanced personal comfort, and also possibly in reduced equipment sizing and corresponding costs.

The primary markets for this measure are commercial and industrial facilities with overhead doors in exterior entryways, including but not limited to the following building types: retail, manufacturing, and warehouse (non-refrigerated).

#### *Limitations*

- For use in conditioned spaces with an overhead door in an exterior entryway. This measure does not include other door types such doorways to commercial spaces such as retail.
- This measure should only be applied to spaces in which the overhead door separates a conditioned space and an unconditioned space.
- Installation must follow manufacturer recommendations to attain proper air velocity, discharge angle down to the floor level, and unit position.
- Certain heating systems may not be a good fit for air curtains, such as locations with undersized heating capacity. In these cases, the installation of an air curtain may not effectively reduce heating system cycling given the inappropriately sized heating capacity.
- Buildings with slightly positive to slightly negative (~5 Pa to -10 Pa). For all other scenarios, custom analysis is recommended.
- Measure assumes that wind speeds at near ground level are less than or equal to 12 mph for 90% of the heating or cooling season. For areas with more extreme weather, custom analysis is necessary.
- Note: for cost effectiveness, it is recommended that minimum door open times should be approximately 15 hours per week.<sup>842</sup>

This measure was developed to be applicable to the following program types: NC, RF. If applied to other program types, the measure savings should be verified.

The following methodology is highly complex and requires significant data collection. It is hoped that simplifying steps can be made in future iterations based on continued metering and evaluation of installations. Also the data collected through implementing the measure in the way currently drafted will aid in simplifying efforts at a future date.

---

<sup>842</sup> Spentzas, Steve, et. al, "1009: Commercial and Industrial Air Curtains – Public Project Report," Nicor Gas Emerging Technology Program (Oct 2014): 9.

**DEFINITION OF EFFICIENT EQUIPMENT**

Overhead air curtains designed for commercial and industrial applications that have been tested and certified in accordance with ANSI/AMCA 220 and installed following manufacturer guidelines. Measure is for standard models without added heating.

**DEFINITION OF BASELINE EQUIPMENT**

No air curtain or other currently installed means to effectively reduce heat loss and air mixing during door openings, such as a vestibule or strip curtain.

**DEEMED LIFETIME OF EFFICIENT EQUIPMENT**

The expected measure life is assumed to be 15 years.<sup>843</sup>

**DEEMED MEASURE COST**

The incremental capital cost for overhead air curtains for exterior entryways are as follows, with an added average installation cost approximately equal to the capital cost.<sup>844</sup>

Door Size	Capital Cost
8'w x 8'h	\$3,600
10'w x 10'h	\$4,500
10'w x 12'h	\$5,400
12'w x 14'h	\$8,000
16'w x 16'h	\$13,300

**LOADSHAPE**

Heating Season: If electric heating, use Commercial Electric Heating Loadshape: C04. Otherwise, N/A

Cooling Season: Commercial Cooling Loadshape C03. Or, if applicable, use Commercial Electric Heating and Cooling Loadshape C05.

**COINCIDENCE FACTOR**

- CF<sub>SSP</sub> = Summer System Peak Coincidence Factor for Commercial cooling (during system peak hour)  
= 91.3%<sup>845</sup>
- CF<sub>PJM</sub> = PJM Summer Peak Coincidence Factor for Commercial cooling (average during peak period)  
= 47.8%<sup>846</sup>

---



---

**Algorithm**

---



---

<sup>843</sup> Navigant Consulting Inc, Measures and Assumptions for Demand Side Management (DSM) Planning: Appendix C: Substantiation Sheets, “Air Curtains – Single Door,” Ontario Energy Board, (April 2009): C-137.

2014 Database for Energy-Efficient Resources, EUL/RUL (Effective/Remaining Useful Life) Values, February 4, 2014.

<sup>844</sup> Based on manufacturer interviews and air curtain specification sheets.

<sup>845</sup> Based on analysis of Itron eShape data for Missouri, calibrated to Illinois loads, supplied by Ameren. The AC load during the utility’s peak hour is divided by the maximum AC load during the year.

<sup>846</sup>Based on analysis of Itron eShape data for Missouri, calibrated to Illinois loads, supplied by Ameren. The average AC load over the PJM peak period (1-5pm, M-F, June through August) is divided by the maximum AC load during the year.

### CALCULATION OF ENERGY SAVINGS

The following formulas provide a methodology for estimating cooling load (kWh) and heating load (therm) savings associated with the installation of air curtains on exterior entryways such as a single door or loading bay. This algorithm is based on the assumption that therm savings are directly related to the difference in cooling or heating losses due to infiltration or exfiltration through an entryway before and after the installation of an AMCA certified air curtain. Energy savings are assumed to be the result of a reduction of natural infiltration effects due to wind and thermal forces and follow the calculation methodology outlined by the ASHRAE Handbook.<sup>847</sup> The calculation assumes that the air curtain is appropriately sized and commissioned to be effective in mitigating infiltration of winds of up to 12 mph for at least 90% of the year (based on manufacturer literature and TMY3 wind speed ranges at near ground level for Illinois).<sup>848</sup> Additionally, this measure assumes the HVAC systems are appropriately balanced such that the maximum pressure differential between indoor air and outdoor air is within the range of  $5 \text{ Pa} < \Delta P < -10 \text{ Pa}$ .<sup>849</sup> Custom analysis is necessary if building pressurization exceeds this range. However, while effectiveness decreases, some studies suggest that air curtains outperform vestibules and single door construction for negatively pressurized buildings with a  $\Delta P$  of above  $-30 \text{ Pa}$ .<sup>850</sup>

This algorithm allows either actual inputs or provides estimates if actual data is not available. All weather dependent values are derived from TMY3 data for the closest weather station to those locations defined elsewhere in the Illinois TRM (which are based on 30 year climate normals). If TMY3 weather station data was not available for the data used in the Illinois TRM, the next closest weather station was used. It is assumed that weather variations are negligible between the weather stations located within the same region. This approach was followed as the air curtain algorithm has a number of weather dependent variables, which are all calculated in relation to the heating season or cooling season as defined by the balance point temperature deemed appropriate for the facility. All weather dependent data is based on TMY3 data and is listed in tables by both climate zone and balance point temperature, which is then normalized to the Illinois TRM climate zoned HDD/CDD definitions unless otherwise noted.

### ELECTRIC ENERGY SAVINGS

$$\Delta \text{kWh}_{\text{cooling}} = [(Q_{\text{tbc}} - Q_{\text{tac}}) / \text{EER} - (\text{HP} * 0.7457)] * t_{\text{open}} * \text{CD}$$

$$\Delta \text{kWh}_{\text{HPheating}} = [(Q_{\text{tbc}} - Q_{\text{tac}}) / \text{HSPF} - (\text{HP} * 0.7457)] * t_{\text{open}} * \text{HD}$$

$$\Delta \text{kWh}_{\text{Gasheating}} = - (\text{HP} * 0.7457) * t_{\text{open}} * \text{HD}$$

Where:

$Q_{\text{tbc}}$  = rate of total heat transfer through the open entryway, before air curtain (kBtu/hr)

$Q_{\text{tac}}$  = rate of total heat transfer through the open entryway, after air curtain (kBtu/hr)

(see calculation in ‘Heat Transfer Through Open Entryway with/without Air Curtain’ sections below)

EER = energy efficiency ratio of the cooling equipment (kBtu/kWh)

= Actual. If unknown, use the table C403.2.3(2) in IECC 2012 (or IECC 2018 or 2021 if through new construction) to assume values based on code estimates.

Note, IECC 2021 is expected to become effective statewide in 2023. IECC 2018 is the requisite code for any projects with permitting dates spanning July 1, 2019 to the IECC 2021 effective date. Prior to July 1, 2019, IECC 2015 is the

<sup>847</sup> ASHRAE, “Ventilation and Infiltration,” in 2013 ASHRAE Handbook – Fundamentals (2013): Ch 16.1 - 16.37.

<sup>848</sup> National Solar Radiation Data Base – 1991 – 2005 Update: Typical Meteorological Year 3, NREL.

<sup>849</sup> Spentzas, Steve, et. al, “1009: Commercial and Industrial Air Curtains – Public Project Report,” Nicor Gas Emerging Technology Program (Oct 2014): 10.

Wang, Liangzhu, “Investigation of the Impact of Building Entrance Air Curtain on Whole Building Energy Use,” Air Movement and Control International, Inc. (2013). 4.

<sup>850</sup> Wang, Liangzhu, “Investigation of the Impact of Building Entrance Air Curtain on Whole Building Energy Use,” Air Movement and Control International, Inc. (2013). 4.



applicable code. As code requirements and adoption can differ from municipality to municipality, the user should verify which version of code is applicable given these constraints.

HP = Input power for air curtain (hp)

= Actual value. If actual value not available, use the following estimates based on manufacturer specs

Door Size	Fan HP
8'w x 8'h	1
10'w x 10'h	1.5
10'w x 12'h	4
12'w x 14'h	6
16'w x 16'h	12

0.7457 = unit conversion factor, brake horsepower to electric power (kW/HP)

t<sub>open</sub> = average hours per day the door is open (hr/day)

= Actual or user defined estimated value.

CD = cooling days per year, total days in year above balance point temperature (day)

= use table below to select the best value for location:<sup>851</sup>

Climate Zone -Weather Station/City	CD (Balance Point Temperature)				
	45 °F	50 °F	55 °F	60 °F	65 °F
1 - Rockford AP / Rockford	194	168	148	124	97
2 - Chicago O'Hare AP / Chicago	194	173	153	127	95
3 - Springfield #2 / Springfield	214	194	174	148	114
4 - Belleville SIU RSCH / Belleville	258	229	208	174	138
5 - Carbondale Southern IL AP / Marion	222	201	181	158	130

HSPF = Heating System Performance Factor of heat pump equipment

= Actual. If unknown, use the table C403.2.3(2) in IECC 2012 (or IECC 2018 or 2021 if through new construction) to assume values based on code estimates.

Note, IECC 2021 is expected to become effective statewide in 2023. IECC 2018 is the requisite code for any projects with permitting dates spanning July 1, 2019 to the IECC 2021 effective date. Prior to July 1, 2019, IECC 2015 is the applicable code. Note IECC 2018 became effective July 1, 2019 and is the baseline for all New Construction permits from that date. As code requirements and adoption can differ from municipality to municipality, the user should verify which version of code is applicable given these constraints.

HD = heating days per year, total days in year above balance point temperature (day)

<sup>851</sup> National Solar Radiation Data Base – 1991 – 2005 Update: Typical Meteorological Year 3, NREL.

Note that cooling days (CD) are calculated by first determining its value from the TMY3 data associated with the appropriate weather station as defined by and used elsewhere in the Illinois TRM. Using the TMY3 outdoor air dry bulb hourly data, the annual hours are totaled for every hour that the outdoor air dry bulb temperature is above a designated zero heat loss balance point temperature or base temperature for cooling. For commercial and industrial (C&I) buildings, a base temperature for heating of 55 °F is designated in the Illinois TRM, but building specific base temperatures are recommended for large C&I projects. Additionally, the TRM uses a 30-year normal data for degree-days while the CD calculation was based on TMY3 data; in order to account for this, calculations of CD were also normalized by the ratio of CDD to align the calculated values more closely with the TRM.

= use table below to select an appropriate value:<sup>852</sup>

Climate Zone Weather Station/City	HD				
	45 °F	50 °F	55 °F	60 °F	65 °F
1 - Rockford AP / Rockford	142	160	183	204	228
2 - Chicago O'Hare AP / Chicago	150	166	192	219	253
3 - Springfield #2 / Springfield	125	142	167	194	230
4 - Belleville SIU RSCH / Belleville	101	115	134	156	180
5 - Carbondale Southern IL AP / Marion	103	123	148	174	205

**Heat Transfer Through Open Entryway without Air Curtain (Cooling Season)**

$$Q_{tbc} = 4.5 * CFM_{tot} * (h_{oc} - h_{ic}) / (1,000 \text{ Btu/kBtu})$$

Where:

4.5 = unit conversion factor with density of air: 60 min/hr \* 0.075 lbm/ft<sup>3</sup> (lb\*min/(ft\*hr))

CFM<sub>tot</sub> = Total air flow through entryway (cfm), see calculation below

h<sub>oc</sub> = average enthalpy of outside air during the cooling season (Btu/lb)

= use the below table to determine the approximate outdoor air enthalpy associated with an indoor temperature setpoint and climate zone.<sup>853</sup>

Climate Zone -Weather Station/City	h <sub>oc</sub>		
	67 °F	72 °F	77 °F
1 - Rockford AP / Rockford	31.6	33.0	35.3
2 - Chicago O'Hare AP / Chicago	32.0	33.6	35.4
3 - Springfield #2 / Springfield	32.9	34.6	36.6
4 - Belleville SIU RSCH / Belleville	33.5	35.0	36.4
5 - Carbondale Southern IL AP / Marion	34.6	36.2	37.7

h<sub>ic</sub> = average enthalpy of indoor air, cooling season (Btu/lb)

= use the below table to determine the approximate indoor air enthalpy associated with an indoor temperature setpoint in indoor relative humidity.

Relative Humidity (%)	h <sub>ic</sub>		
	67 °F	72 °F	77 °F
60	25.5	28.5	31.8
50	23.9	26.6	29.5
40	22.3	24.7	27.3

= an estimate 26.6 Btu/lb associated with the 72 °F and 50% indoor relative humidity case can be used as an approximation if no other data is available. For other indoor temperature setpoints and RH, enthalpies may be interpolated.

<sup>852</sup> Note that Heating Days (HD) are calculated following the same approach outlined in the Cooling Days section.

<sup>853</sup> Average enthalpies were estimated following ASHRAE guidelines for perfect gas relationships for dry air associated with hourly TMY3 data. Enthalpies were then averaged for all values associated with a dry-bulb outdoor air temperature that exceeded the indoor air temperature setpoint. Other enthalpy values may be interpolated for indoor air temperature setpoints not represented in the table. Note that while outdoor air enthalpies increase with higher temperature setpoints, the change in enthalpy from indoor to outdoor will decrease.

The total airflow through the entryway,  $CFM_{tot}$ , includes both infiltration due to wind as well as thermal forces, as follows:

$$CFM_{tot} = \text{sqrt}[(CFM_w)^2 + (CFM_t)^2]$$

Where:

$CFM_w$  = Infiltration due to the wind (cfm)

$CFM_t$  = Infiltration due to thermal forces (cfm)

The infiltration due to the wind is calculated as follows:

$$CFM_w = (v_{wc} * C_{wc}) * C_v * A_d * (88 \text{ fpm/mpH})$$

Where:

$v_{wc}$  = average wind speed during the cooling season based on entryway orientation (mph)

= use the below table to for the wind speed effects based on climate zone and entryway orientation:<sup>854</sup>

Climate Zone -Weather Station /City	Entryway Orientation			
	N	E	S	W
1 - Rockford AP / Rockford	4.2	4.1	4.7	4.8
2 - Chicago O'Hare AP / Chicago	4.7	4.5	5.4	4.6
3 - Springfield #2 / Springfield	4.1	3.7	6.0	5.0
4 - Belleville SIU RSCH / Belleville	3.3	2.7	3.8	4.2
5 - Carbondale Southern IL AP / Marion	3.1	2.9	4.4	3.8

$C_{wc}$  = wind speed correction factor due to wind direction in cooling season (%)

= because wind direction is not constant, a wind speed correction factor is used to adjust for the amount of time during the cooling season prevailing winds can be expected to impact the entryway. Use the following table to determine the correct wind speed correction factor for cooling applications.

Climate Zone -Weather Station /City	Entryway Orientation			
	N	E	S	W
1 - Rockford AP / Rockford	0.18	0.13	0.30	0.31
2 - Chicago O'Hare AP / Chicago	0.18	0.17	0.36	0.26
3 - Springfield #2 / Springfield	0.17	0.12	0.46	0.21
4 - Belleville SIU RSCH / Belleville	0.21	0.15	0.35	0.16
5 - Carbondale Southern IL AP / Marion	0.18	0.15	0.37	0.11

Note that correction factors do not add up to 1 (100%). This is attributed to periods of calm winds.

$C_v$  = effectiveness of openings,

= 0.3, assumes diagonal wind<sup>855</sup>

$A_d$  = area of the doorway (ft<sup>2</sup>)

= user defined

<sup>854</sup> Average wind speeds are calculated based on the TMY3 wind speed data. Because this data is collected at an altitude of 33 ft, wind speed is approximated for a 5 ft level based on ASHRAE Handbook guidelines using the urban/suburban parameters for adjusting wind speed based on altitude (Layer thickness (ft)  $\delta = 1200$ , Exponent  $a = 0.22$ ).

ASHRAE, "Airflow Around Buildings," in 2013 ASHRAE Handbook – Fundamentals (2013): p 24.3.

<sup>855</sup> ASHRAE, "Ventilation and Infiltration," in 2013 ASHRAE Handbook – Fundamentals (2013): p 16.13

The infiltration due to thermal forces is calculated as follows:

$$CFM_t = A_d * C_{dc} * (60 \text{ sec/min}) * \text{sqrt}[2 * g * H/2 * (T_{oc} - T_{ic}) / (459.7 + T_{oc})]$$

Where:

$C_{dc}$  = the discharge coefficient during the cooling season<sup>856</sup>  
 =  $0.4 + 0.0025 * |T_{ic} - T_{oc}|$   
 = 0.42, Illinois average at indoor air temp of 72°F

Note, values for  $C_{dc}$  show little variation due to balance point temperature, indoor air temperature, and climate zone. As such, if estimating results, the Illinois average value may be used as a simplification.

$g$  = acceleration due to gravity  
 = 32.2 ft/sec<sup>2</sup>

$H$  = the height of the entryway (ft)  
 = user input

$T_{ic}$  = Average indoor air temperature during cooling season  
 = User input, can assume indoor cooling temperature set-point

$T_{oc}$  = Average outdoor temp during cooling season (°F)  
 = the average outdoor temperature is dependent on the CD period and zone. As such, the following table may be used for average outdoor temperature during the cooling period.<sup>857</sup>

Climate Zone Weather Station/City	$T_{oc}$				
	62 °F	67 °F	72 °F	77 °F	82 °F
1 - Rockford AP / Rockford	72.9	76.0	79.2	82.5	85.5
2 - Chicago O'Hare AP / Chicago	72.9	76.0	79.4	82.8	85.5
3 - Springfield #2 / Springfield	73.7	76.7	79.9	83.4	86.4
4 - Belleville SIU RSCH / Belleville	74.9	77.7	81.0	84.3	86.9
5 - Carbondale Southern IL AP / Marion	75.1	77.7	80.9	84.7	87.4

459.7 = conversion factor from °F to °R  
 = calculation requires absolute temperature for values not calculated as a difference of temperatures.

**Heat Transfer Through Open Entryway with Air Curtain (Cooling Season)**

$$Q_{tac} = Q_{tbc} * (1 - E)$$

Where:

$E$  = the effectiveness of the air curtain (%)  
 = 0.60<sup>858</sup>

<sup>856</sup> ASHRAE, "Ventilation and Infiltration," in 2013 ASHRAE Handbook – Fundamentals (2013): p 16.13.

<sup>857</sup> Based on binned data from TMY3 & adjusted bracketed thermostat setpoint temperatures. Interpolate other values as needed.

<sup>858</sup> Assumed conservative estimate based on referenced study results and ASHRAE 2004 effectiveness range of 60-80% for air curtains. Jaramillo, Julian, et. Al. "Application of Air Curtains in Refrigerated Chambers," International Refrigeration and Air-Conditioning Conference, Purdue University e-Pubs (July 14-17, 2008).  
 ASHRAE, "Room Air Distribution Equipment," in 2004 ASHRAE Handbook – HVAC Systems and Equipment (2004): p 17.8.

**SUMMER COINCIDENT PEAK DEMAND SAVINGS**

$$\Delta kW = (\Delta kWh_{cooling} / (CD * 24)) * CF$$

Where:

- CF<sub>SSP</sub> = Summer System Peak Coincidence Factor for Commercial cooling (during system peak hour)  
= 91.3%<sup>859</sup>
- CF<sub>PJM</sub> = PJM Summer Peak Coincidence Factor for Commercial cooling (average during peak period)  
= 47.8%<sup>860</sup>

**FOSSIL FUEL SAVINGS**

Natural gas savings, Δtherms, associated with reduced infiltration through an entryway during the heating season are calculated by determining the difference between heat loss through the entryway before and after the installation of the air curtain.

$$\Delta thermos = (Q_{bc} - Q_{ac}) * t_{open} * HD / \eta$$

Where:

- Q<sub>bc</sub> = rate of sensible heat transfer through the open entryway, before air curtain (therm/hr)
- Q<sub>ac</sub> = rate of sensible heat transfer through the open entryway, after air curtain (therm/hr)
- t<sub>open</sub> = average hours per day the door is open (hr/day)  
= Actual or estimated user input value
- HD = heating days per year, total days in year above balance point temperature (day)  
= use table below to select an appropriate value:<sup>861</sup>

Climate Zone - Weather Station/City	HD				
	45 °F	50 °F	55 °F	60 °F	65 °F
1 - Rockford AP / Rockford	142	160	183	204	228
2 - Chicago O'Hare AP / Chicago	150	166	192	219	253
3 - Springfield #2 / Springfield	125	142	167	194	230
4 - Belleville SIU RSCH / Belleville	101	115	134	156	180
5 - Carbondale Southern IL AP / Marion	103	123	148	174	205

- η = efficiency of heating equipment  
= Actual. If unknown, assume 0.8

**Heat Transfer Through Open Entryway without Air Curtain (Heating Season)**

$$Q_{bc} = (1.08 \text{ Btu}/(\text{hr} * \text{°F} * \text{cfm})) * \text{CFM}_{tot} * (T_{ih} - T_{oh}) / (100,000 \text{ Btu/therm})$$

Where:

- 1.08 = sensible heat transfer coefficient (specific heat of air and unit conversions)

<sup>859</sup> Based on analysis of Itron eShape data for Missouri, calibrated to Illinois loads, supplied by Ameren. The AC load during the utility's peak hour is divided by the maximum AC load during the year.

<sup>860</sup> Based on analysis of Itron eShape data for Missouri, calibrated to Illinois loads, supplied by Ameren. The average AC load over the PJM peak period (1-5pm, M-F, June through August) is divided by the maximum AC load during the year

<sup>861</sup> Note that Heating Days (HD) are calculated following the same approach outlined in the Cooling Days section.

$CFM_{tot}$  = Total air flow through entryway (cfm)

$T_{ih}$  = Average indoor air temperature during heating season  
 = User input, can assume indoor heating temperature set-point

$T_{oh}$  = Average outdoor temp during heating season (°F)  
 = use table below, based on binned data from TMY3 & balance point temperature:

Climate Zone -Weather Station/City	Avg Outdoor Air Temp - Heating Season				
	45 °F	50 °F	55 °F	60 °F	65 °F
1 - Rockford AP / Rockford	26.3	28.8	31.6	34.2	37.3
2 - Chicago O'Hare AP / Chicago	29.4	31.2	34.0	36.8	40.3
3 - Springfield #2 / Springfield	29.4	31.5	34.6	37.7	41.6
4 - Belleville SIU RSCH / Belleville	31.7	33.6	36.2	39.2	42.3
5 - Carbondale Southern IL AP / Marion	32.5	34.9	37.8	40.7	44.0

The total airflow through the entryway,  $CFM_{tot}$ , includes both infiltration due to wind as well as thermal forces, as follows:

$$CFM_{tot} = \text{sqrt}[(CFM_w)^2 + (CFM_t)^2]$$

Where:

$CFM_w$  = Infiltration due to the wind (cfm)

$CFM_t$  = Infiltration due to thermal forces (cfm)

The infiltration due to the wind is calculated as follows:

$$CFM_w = (v_{wh} * C_{wh}) * C_v * A_d * (88 \text{ fpm/mph})$$

Where:

$v_{wh}$  = average wind speed during the heating season (mph)

= similar to cooling season wind speed assumptions, use the following table to determined average wind speed based on entryway orientation:

Climate Zone -Weather Station/ City	Entryway Orientation			
	N	E	S	W
1 - Rockford AP / Rockford	5.0	4.6	4.9	5.6
2 - Chicago O'Hare AP / Chicago	5.5	5.2	4.9	5.1
3 - Springfield #2 / Springfield	5.0	4.9	5.3	5.1
4 - Belleville SIU RSCH / Belleville	4.3	3.4	3.5	5.3
5 - Carbondale Southern IL AP / Marion	4.6	3.2	4.2	4.4

$C_{wh}$  = wind speed correction factor due to wind direction in heating season, (%)

= because wind direction is not constant, a wind speed correction factor is used to adjust for the amount of time during the heating season prevailing winds can be expected to impact the entryway. Use the following table to determine the correct wind speed correction factor for the heating applications.

Climate Zone -Weather Station/ City	Entryway Orientation			
	N	E	S	W
1 - Rockford AP / Rockford	0.18	0.13	0.30	0.31
2 - Chicago O'Hare AP / Chicago	0.21	0.10	0.26	0.39

3 - Springfield #2 / Springfield	0.21	0.14	0.27	0.34
4 - Belleville SIU RSCH / Belleville	0.31	0.15	0.22	0.29
5 - Carbondale Southern IL AP / Marion	0.31	0.11	0.27	0.18

Note that correction factors do not add up to 1 (100%). This is attributed to periods of calm winds.

$C_v$  = effectiveness of openings,  
= 0.3, assumes diagonal wind<sup>862</sup>

$A_d$  = area of the doorway (ft<sup>2</sup>)  
= user input

The infiltration due to thermal forces is calculated as follows:

$$CFM_t = A_d * C_{dh} * (60 \text{ sec/min}) * \text{sqrt}[2 * g * H/2 * (T_{ih} - T_{oh}) / (459.7 + T_{ih})]$$

Where:

$C_{dh}$  = the discharge coefficient during the heating season  
=  $0.4 + 0.0025 * |T_{ih} - T_{oh}|$   
= 0.49, Illinois average at indoor air temp of 72°F

Note, values for  $C_{dh}$  show little variation due to balance point temperature, indoor air temperature, and climate zone. As such, if estimating results, the Illinois average value may be used as a simplification.

$g$  = acceleration due to gravity  
= 32.2 ft/sec<sup>2</sup>

$H$  = the height of the entryway (ft)  
= user defined

**Heat Transfer Through Open Entryway without Air Curtain (Heating Season)**

$$Q_{ac} = Q_{bc} * (1 - E)$$

Where:

$E$  = the effectiveness of the air curtain (%)  
= 0.60<sup>863</sup>

**WATER AND OTHER NON-ENERGY IMPACT DESCRIPTIONS AND CALCULATION**

N/A

**DEEMED O&M COST ADJUSTMENT CALCULATION**

The air curtain would need to be regularly serviced and commissioned to ensure that it is appropriately operating. This is estimated at a cost of \$150.<sup>864</sup>

<sup>862</sup> ASHRAE, "Ventilation and Infiltration," in 2013 ASHRAE Handbook – Fundamentals (2013): p 16.13

<sup>863</sup> Assumed conservative estimate based on referenced study results and ASHRAE 2004 effectiveness range of 60-80% for air curtains. Jaramillo, Julian, et. Al. "Application of Air Curtains in Refrigerated Chambers," International Refrigeration and Air-Conditioning Conference, Purdue University e-Pubs (July 14-17, 2008).

ASHRAE, "Room Air Distribution Equipment," in 2004 ASHRAE Handbook – HVAC Systems and Equipment (2004): p 17.8.

<sup>864</sup> Assumes approximately 1 hour of maintenance (include cleaning out filters, greasing, and checking that the designed angle of attack on the blower nozzle is at the designed position) based on manufacturer input and product spec sheets.

**MEASURE CODE: CI-HVC-AIRC-V06-240101**

**REVIEW DEADLINE: 1/1/2024**



#### 4.4.34 Destratification Fan

##### DESCRIPTION

This measure applies to buildings with high bay ceiling construction without fans currently installed for the purpose of destratifying air. There is also a separate measure for destratification fans as applied to agricultural settings (“High Volume Low Speed Fans”). All other destratification fan applications require custom analysis.

Air stratification leads to higher temperatures at the ceiling and lower temperatures at the ground. During the heating season, destratification fans improve air temperature distribution in a space by circulating warmer air from the ceiling back down to the floor level, thereby enhancing comfort and saving energy. Energy savings are realized by a reduction of heat loss through the roof-deck and walls as a result of a smaller temperature differential between indoor temperature and outdoor air.

Note that further, but limited, empirical evidence suggests that improved air mixing due to destratification would also result in shorter heating system runtimes due to warmer air reaching the thermostat level sooner, and possibly even allow a facility to lower the thermostat set point while maintaining a similar level of occupant comfort. This is supported by measured data in which an increase in temperatures was observed at the thermostat (5 foot level) level when air is destratified, resulting in an approximate temperature increase at the 5 foot level in the range of 1 – 3°F.<sup>865</sup> This measure does not currently attempt to quantify the potential impacts of air mixing from destratification; however, it should be noted that additional therms savings may be possible.

This measure was developed to be applicable to the following program types: NC, RF. If applied to other program types, the measure savings should be verified.

##### *Limitations*

- For use in conditioned, high bay structures. Recommended minimum ceiling height of 20 ft.
- This measure should only be applied to spaces in which the ceiling is subject to heat loss to outdoor air (i.e., single story or top floor spaces) and where there is sufficient space to allow for appropriate spacing of the fans. Other applications require custom analysis.
- Installation must follow manufacturer recommendations sufficient to effectively destratify the entire space. Please see calculation of effective area,  $A_{eff}$ , in the therms savings algorithm as a check if this criteria is met. Otherwise, custom calculation is necessary.
- Measure does not currently support facilities with night setbacks on heating equipment. Custom analysis is needed in this case.
- Certain heating systems may not be a good fit for destratification fans, such as locations with: high velocity vertical throw unit heaters, radiant heaters, and centralized forced air systems. In these cases, measured evidence of stratification should be confirmed, and custom analysis may be necessary.

##### DEFINITION OF EFFICIENT EQUIPMENT

High Volume, Low Speed (HVLS) fans with a minimum diameter of 14 ft with Variable Speed Drive (VSD) installed.<sup>866</sup>

Note that bell-shaped fans are currently excluded from this measure due to limited validation of the technology available. Further verification of effectiveness compared to HVLS is needed. A manufacturer of bell-shaped fans indicates that four bell-shaped fans provide an equivalent effective area as a typical HVLS fan. However, there is a need for further review of bell-shaped fan field test data supporting manufacturer claims regarding comparable effectiveness to HVLS technologies.

---

<sup>865</sup> Kosar, Doug, “1026: Destratification Fans – Public Project Report,” Nicor Gas, Emerging Technology Program (Oct 2014): 16.

<sup>866</sup> Kosar, Doug, “1026: Destratification Fans – Public Project Report,” Nicor Gas, Emerging Technology Program (Oct 2014): 16.

**DEFINITION OF BASELINE EQUIPMENT**

No destratification fans or other means to effectively mix indoor air.

**DEEMED LIFETIME OF EFFICIENT EQUIPMENT**

The expected measure life is assumed to be 10 years.<sup>867</sup>

**DEEMED MEASURE COST**

The incremental measure cost = [equipment cost of HVLS fans] + [installation costs (including materials and labor)]

Since installation cost is dependent on a variety of factors, actual costs should be used if known. The default incremental measure cost for HVLS fans are as follows:<sup>868</sup>

Fan Diameter (ft)	Incremental Cost
14	\$6,600
16	\$6,650
18	\$6,700
20	\$6,750
22	\$6,800
24	\$6,850

**LOADSHAPE**

Loadshape C04: Commercial Electric Heating.

**COINCIDENCE FACTOR**

There are no summer coincident peak demand savings for this measure due to no savings attributable to cooling during the summer peak period.

---

**Algorithm**

---

**CALCULATION OF SAVINGS**

The following formulas provide a methodology for estimating heating load savings associated with destratification fan use. This algorithm is based on the assumption that savings are directly related to the difference in heat loss through the envelope before and after destratification.

**ELECTRIC ENERGY SAVINGS**

The algorithm for this measure was developed for natural gas heating applications, however, for electric heating applications, the same methodology presented in the Fossil Fuel Savings Section may be used with the standard conversion factor from therms to kWh of 29.31 kWh/therm and an equipment efficiency as follows:

System Type	Cooling Capacity of Equipment	Age of Equipment	HSPF Estimate	η (Effective COP Estimate) (HSPF/3.413)
	All	Before 2009	6.8	2.0

<sup>867</sup> Consistent with both 2008 Database for Energy-Efficient Resources, EUL/RUL (Effective/Remaining Useful Life) Values, October 10, 2008 and GDS Associates, Inc, "Measure Life Report: Residential and Commercial/Industrial Lighting and HVAC Measures," New England Stat Program Working Group (June 2007), p30.

<sup>868</sup> Costs were obtained from manufacturer interviews and are based off of average or typical prices for base model HVLS fans. Costs include materials and labor to install the fans and tie fans into an existing electrical supply located near the fan.

System Type	Cooling Capacity of Equipment	Age of Equipment	HSPF Estimate	$\eta$ (Effective COP Estimate) (HSPF/3.413)
<b>Heat Pump</b> <sup>869</sup>	< 65,000 Btu/h	2009 - 2017	7.7	2.3
		2017 on	8.2	2.40
	$\geq 65,000$ Btu/h and < 135,000 Btu/h	2010 on	11.3	3.3
	$\geq 135,000$ Btu/h and < 240,000 Btu/h	2010 on	10.9	3.2
	$\geq 240,000$ Btu/h and < 760,000 Btu/h	2010 on	10.9	3.2
<b>Resistance</b>	N/A	N/A	N/A	1

Regardless of how the building is heated, the energy consumption of the fans must be accounted for. If the building is electrically heated, fan energy shall be subtracted from the savings as calculated above. If the building is heated with natural gas, this shall represent an electric penalty, i.e., an increase in consumption. This is calculated as follows:

$$\Delta kWh = - (W_{fan} * N_{fan}) * t_{eff}$$

$W_{fan}$  = fan input power (kW)  
 $N_{fan}$  = number of fans  
 $t_{eff}$  = effective annual operation time, based on balance point temperature (hr)  
 = see table below in Fossil Fuel Savings section for further detail

**SUMMER COINCIDENT PEAK DEMAND SAVINGS**

N/A

**FOSSIL FUEL SAVINGS**

$$\Delta Therms = [(\Delta Q_r + \Delta Q_w) * t_{eff}] / (100,000 * \eta)$$

Where:

- $\Delta Q_r$  = the heat loss reduction through the roof due to the destratification fan (Btu/hr)  
= See calculation section below
- $\Delta Q_w$  = the heat loss reduction through the exterior walls due to destratification fan (Btu/hr)

<sup>869</sup> Minimum heating efficiency standards for heat pumps are sourced from the Code of Federal Standards for Small and Large Commercial Package Air Conditioning and Heating Equipment (Air Cooled), 10 CFR 431.97 with compliance dates of June 16, 2008; January 1, 2010; January 1, 2017; and January 1, 2018. As the first federal appliance standards for heating efficiency for commercial heat pumps went into effect in June 2008, assuming efficiency standards equivalent to residential heat pumps prior to that date. Note, new Federal Standards affecting heat pumps become effective January 1, 2023. In order to allow for existing inventory meeting the previous federal standards to clear shelves, this measure characterization will incorporate these federal appliance standards as an equipment efficiency option on January 1, 2024. If the application of this measure is in a new construction building, the HVAC equipment efficiency should be sourced from the applicable code edition of IECC. As code requirements and adoption can differ from municipality to municipality, the user should verify which version of code is applicable given these constraints. Note, IECC 2021 is expected to become effective statewide in 2023. IECC 2018 is the requisite code for any projects with permitting dates spanning July 1, 2019 to the IECC 2021 effective date. Prior to July 1, 2019, IECC 2015 is the applicable code. If evaluation determines the applicable version of code, given location and timing, isn't an appropriate baseline due to supply constraints, low compliance, or other issues, the previous iteration of code may be used through 2023.

= See calculation section below

$t_{eff}$  = effective annual operation time, based on balance point temperature (hr)

= use table below to select an appropriate value:<sup>870</sup>

Climate Zone -Weather Station/City	$t_{eff}$				
	45 °F	50 °F	55 °F	60 °F	65 °F
1 - Rockford AP / Rockford	3810	4226	4880	5571	6436
2 - Chicago O'Hare AP / Chicago	3593	3986	4603	5254	6070
3 - Springfield #2 / Springfield	3038	3370	3891	4442	5131
4 - Belleville SIU RSCH / Belleville	2243	2488	2873	3280	3789
5 - Carbondale Southern IL AP / Marion	2271	2519	2909	3320	3836

100,000 = conversion factor (1 therm = 100,000 Btu)

$\eta$  = thermal efficiency of heating equipment

= Actual. If unknown, assume 0.8.

**For example**, for a warehouse facility located in Rockford, IL, installing destratification fans could reduce heat loss through the roof of 95,000 Btu/hr and a reduced heat loss through the wall of 51,228 Btu/hr. Assuming a balance point of 55°F the therms savings for the facility would be estimated as:

$$\begin{aligned} \Delta \text{Therms} &= [(\Delta Q_r + \Delta Q_w) * t_{eff}] / (100,000 * \eta) \\ &= [(95,000 \text{ Btu/hr} + 51,228 \text{ Btu/hr}) * 4880 \text{ hr}] / [(100,000 \text{ Btu/therm}) * 0.8] \\ &= 8,923 \text{ therms} \end{aligned}$$

**Heat loss reduction through the roof**

$$\begin{aligned} \Delta Q_r &= Q_{r,s} - Q_{r,d} \\ &= (1/R_r) * A_r * [(T_{r,s} - T_{oa}) - (T_{r,d} - T_{oa})] \\ &= (1/R_r) * A_r * (T_{r,s} - T_{r,d}) \end{aligned}$$

Where:

$Q_{r,s}$  = roof heat loss for stratified space

$Q_{r,d}$  = roof heat loss for destratified space

$R_r$  = overall thermal resistance through the roof (hr · ft<sup>2</sup> · °F / Btu)

= Actual or estimated based on construction type. If unknown, assume the following:

Thermal Resistance Factor (R-Factor) for Roof	Retrofit <sup>871</sup>	New Construction <sup>872</sup>
$R_r$	15.0 (hr · ft <sup>2</sup> · °F / Btu)	30.0 (hr · ft <sup>2</sup> · °F / Btu)

$A_r$  = roof area (ft<sup>2</sup>)

<sup>870</sup> These were calculated at various base temperatures using TMY3 data and adjusted to make consistent with the 30 year normal data used elsewhere. For more information see 'Destratification Fan Workpaper'; Robert Irmiger, Gas Technology Institute, 9/6/2015.

<sup>871</sup> Professional judgement was used to address older vintage structures and an estimate of 50% of current code standard was used.

<sup>872</sup> Consistent with IECC 2015/2018/2021 code requirements.

- = user input
- = can be approximated with floor area
- $T_{oa}$  = outside air temperature, note: therm savings calculations are actually independent of outside air because this term drops out of the heat loss reduction equation
- $T_{r,s}$  = indoor temperature at roof deck, stratified case (°F)  
= Actual. If unknown, use the following equation  
=  $m_s * h_r + T_{f,s}$
- $h_r$  = ceiling height/roof deck (ft)
- $m_s$  = estimated heat gain per foot elevation, stratified case (°F/ft)  
= 0.8 °F/ft  
= Professional judgement used to define value based on result from a Nicor Gas ETP Pilot field testing results and the Ansley article below.<sup>873,874</sup> Estimates from these sources fall on the conservative side of the industry rule of thumb range of 1-2 °F/ft heat gain.
- $T_{f,s}$  = estimated floor temperature, stratified case (°F)  
=  $T_{tstat} - m_s * h_{tstat}$   
=  $T_{tstat} - 4$  °F
- $T_{tstat}$  = temperature set point at the thermostat
- $h_{tstat}$  = vertical distance between the floor and the thermostat, assumed 5ft
- $T_{r,d}$  = indoor temp at roof, destratified case  
= actual value, or may be estimated using the following:<sup>875,876</sup>  
=  $T_{tstat} + 1$  °F

**For example**, for a 50,000 ft<sup>2</sup> warehouse built in 1997 with 30 ft ceilings and a thermostat set point of 65°F. No further measured values available.

$$\begin{aligned} \Delta Q_r &= (1/R_r) * A_r * (T_{r,s} - T_{r,d}) = (1/R_r) * A_r * [(m_s * h_r + T_{tstat} - 4 \text{ °F}) - (T_{tstat} + 1 \text{ °F})] \\ &= (1/R_r) * A_r * [(0.8\text{°F/ft} * h_r) - 5 \text{ °F}] \\ &= 1/(10 \text{ hr} \cdot \text{ft}^2 \cdot \text{°F} / \text{Btu}) * (50,000 \text{ ft}^2) * [(0.8\text{°F/ft} * 30 \text{ ft}) - 5 \text{ °F}] \\ &= 95,000 \text{ Btu/hr} \end{aligned}$$

**Heat loss reduction through exterior walls**

Note: a conservative estimate for therms savings would neglect the impact of heat loss through the walls. However, Ansley suggests that estimates based on the roof deck losses alone underestimate actual savings by up to 46%.<sup>877</sup>

$$\Delta Q_w = Q_{w,s} - Q_{w,d}$$

<sup>873</sup> Kosar, Doug, “1026: Destratification Fans – Public Project Report,” Nicor Gas, Emerging Technology Program (Oct 2014): 10-11. Field testing results indicated approximately 0.6 °F/ft for a garden center.

<sup>874</sup> Aynsley, Richard, “Saving Heating Costs in Warehouses,” ASHRAE Journal (Dec 2005): 48. Identifies a 0.8 °F/ft gain.

<sup>875</sup> Kosar, Doug, “1026: Destratification Fans – Public Project Report,” Nicor Gas, Emerging Technology Program (Oct 2014): 10-11. Field testing results indicated approximately 0.6 °F/ft for a garden center.

<sup>876</sup> Aynsley, Richard, “Saving Heating Costs in Warehouses,” ASHRAE Journal (Dec 2005): 48.

<sup>877</sup> Aynsley, Richard, “Saving Heating Costs in Warehouses,” ASHRAE Journal (Dec 2005): 51.

$$= (1/R_w) * A_w * (T_{w,s} - T_{w,d})$$

Where:

$R_w$  = overall thermal resistance through the exterior walls (hr · ft<sup>2</sup> · °F / Btu)  
 = Actual or estimated based on construction type.<sup>878</sup> If unknown, assume the following:

Thermal Resistance Factor (R-Factor) for Wall	Retrofit <sup>879</sup>	New Construction <sup>880</sup> (2010 or newer)
$R_w$	6.5 (hr · ft <sup>2</sup> · °F / Btu)	13.0 (hr · ft <sup>2</sup> · °F / Btu)

$A_w$  = area of exterior walls (ft<sup>2</sup>)  
 = user input

$T_{w,s}$  = average indoor air temperature for wall heat loss, stratified case  
 = If actual  $T_{r,s}$  measurement is available<sup>881</sup>  

$$= [(T_{r,s} * h_a) + (T_{tstat} * h_b)] / h_r$$

$$h_a = \text{vertical distance between the heat source and the ceiling}$$

$$h_b = \text{vertical distance between the floor and the heat source}$$
 = Otherwise, use the linear stratification equation at average space height, see definition above.  

$$= m_s * (h_r / 2) + T_{f,s}$$

$$= m_s * (h_r / 2) + (T_{tstat} - 4)$$

$T_{w,d}$  = average indoor air temperature for wall heat loss, destratified case  
 =  $T_{tstat} + 0.5$   
 = conservative estimate using engineering judgment based on the same assumption used for  $T_{r,f}$  estimate.

**For example,** for a 50,000 ft<sup>2</sup> warehouse built in 1997 with 1200 ft length of perimeter wall and 30 ft ceilings and a thermostat set point of 65°F and a measured temperature at the ceiling of 85°F and unit heaters located 10 feet from the roof:

$$\begin{aligned} \Delta Q_w &= (1/R_w) * A_w * (T_{w,s} - T_{w,d}) \\ &= (1/R_w) * A_w * [([(T_{r,s} * h_a) + (T_{tstat} * h_b)] / h_r) - (T_{tstat} + 0.5 \text{ °F})] \\ &= 1/(6.5 \text{ hr}\cdot\text{ft}^2\cdot\text{°F/Btu}) * (1200 * 30) * [([(85\text{°F} * 10\text{ft}) + (65\text{°F} * 20\text{ft})] / 30\text{ft}) - (65 + 0.5 \text{ °F})] \\ &= 1/(6.5 \text{ hr}\cdot\text{ft}^2\cdot\text{°F/Btu}) * (36,000\text{ft}^2) * (71.7 \text{ °F} - 65.5 \text{ °F}) \\ &= 34,338 \text{ Btu/hr} \end{aligned}$$

<sup>878</sup> Because heat loss through the walls is estimated using the average space temperature pre- and post- destratification. There are a number of factors that can impact the average space temperature causing deviations from estimates of many degrees in some cases. As such, it is recommended that a conservative value for the thermal resistance through the walls,  $R_w$ , be used. A recommended method for determining  $R_w$  would be to use the highest R-value for the wall space, neglecting lower R-values associated with windows, thermal bridges, etc.

<sup>879</sup>ANSI/ASHRAE/IESNA 100-1995, “Energy Conservation in Existing Buildings,” ASHRAE Standard (1995). Additionally, professional judgement was used to address older vintage structure prior to adoption of the 1995 standard and an estimate of 50% of current code standard was used.

<sup>880</sup>ANSI/ASHRAE/IESNA Standard 90.1-2007, “Energy Standard for Buildings Except Low-Rise Residential Buildings,” ASHRAE Standard (2007): Table 5.5-4 and Table 5.5-5.

<sup>881</sup> Aynsley, Richard, “Saving Heating Costs in Warehouses,” ASHRAE Journal (Dec 2005): 48.

**Measure eligibility check**

Use the following algorithm to verify a fan system is sufficiently sized to destratify air across the entire area.

Effective area,  $A_{eff}$ , is the area over which a fan or a group of fans can be expected to effectively destratify a space. If  $A_{eff}$  is less than the roof area,  $A_r$ , a custom analysis approach should be followed to account for the change in the effectiveness of the system. In lieu of more detailed studies, effective area is defined based on the measured results from an Enbridge Gas field study in which the area a fan was expected to effectively destratify was equal to 5 times the fan diameter.<sup>882</sup> Effective area, is calculated as follows:

$$A_{eff} = [\pi * (5 * D_{fan})^2] / 4 * N_{fan}$$

$$= 6.25 * \pi * D_{fan}^2 * N_{fan}$$

Where:

- $A_{eff}$  = the effective area fan area on the floor (ft<sup>2</sup>)
- $D_{fan}$  = fan diameter
- $N_{fan}$  = the number of fans

**WATER IMPACT DESCRIPTIONS AND CALCULATION**

N/A

**DEEMED O&M COST ADJUSTMENT CALCULATION**

N/A

**MEASURE CODE: CI-HVC-DSFN-V07-240101**

**REVIEW DEADLINE: 1/1/2025**

---

<sup>882</sup> Enbridge Gas Distribution, Inc., “Big Fans Deliver Big Bonus,” (Aug 2007). Additionally, multiple utilities have adopted this definition in their programs in including Enbridge Gas and Consumers Energy.

## 4.4.35 Economizer Repair and Optimization

### DESCRIPTION

Economizers are designed to use unconditioned outside air (OA) instead of mechanical cooling to provide cooling when exterior conditions permit. When the OA temperature is less than the changeover temperature (determined by a static setpoint or a reference return air sensor) up to 100% OA is supplied to help meet the facility's cooling needs, thus reducing mechanical cooling energy and saving energy. An economizer that is not working or is not properly adjusted can waste energy and cause comfort issues. This HVAC measure involves the repair and optimization of common economizer problems such as adjusting changeover setpoint, repairing damper motors and linkages, and replacing non-working sensors and/or controllers. These repairs and adjustments result in proper operation which maximizes both occupant comfort and energy savings.

This measure is only appropriate for single zone packaged rooftop units. Custom calculations are required for savings for multi-zone systems.

In general, the HVAC Economizer Optimization measure may involve both repair and/or optimization, as below.

**Economizer Repair** – The economizer repair work is performed to ensure that the existing economizer is working properly. This allows the system to take advantage of free cooling and ensure that the system is not supplying an excess amount of OA during non-economizing periods.

- **Replace Damper Motor** – If the existing damper motor is not operational, the unit will be replaced with a functioning motor to allow proper damper modulation.
- **Repair Damper Linkage** – If the existing linkage is broken or not adjusted properly, the unit will be replaced or adjusted to allow proper damper modulation.
- **Repair Economizer Wiring** – If the existing economizer is not operational due to a wiring issue, the issue will be repaired to allow proper economizer operation.
- **Reduce Over Ventilation** – If the unit is supplying excess OSA, the OSA damper position will be adjusted to meet minimum ventilation requirements.
- **Replace Economizer Sensor**– If the unit is equipped with a nonadjustable dry bulb (i.e., snapdisk) or malfunctioning analog sensor, the sensor is replaced with a new selectable sensor.
- **Replace Economizer Control**– If the existing economizer controller is not operational, the unit will be replaced or upgraded to allow for proper economizer operation.

**Economizer Optimization** – The economizer optimization work is performed to ensure that the existing economizer system is set up properly to maximize use of free cooling for units located in a particular climate zone.

- **Economizer Changeover Setpoint Adjustment** – If the unit is equipped with a fully operational economizer, the controller is adjusted to the appropriate changeover setpoint based on ASHRAE 90.1 (Figure 1 - *Table 6.5.1.1.3 High-Limit Shutoff Control Settings for Air Economizers*) for the corresponding climate zone.
- **Enable Integrated Operation** – If the unit is equipped with a fully operational economizer and is not set up to allow a minimum of two stages of cooling (1<sup>st</sup> stage – Economizer Only & 2<sup>nd</sup> Stage – Economizer & Mechanical cooling), the unit will be wired to allow two stage cooling

This measure was developed to be applicable to the following program types: RF, DI.

If applied to other program types, the measure savings should be verified.



**DEFINITION OF EFFICIENT EQUIPMENT**

The efficient equipment condition is defined by fully functional economizer that is programmed to meet ASHRAE 90.1 economizer changeover setpoint requirements for the facility’s climate zone and changeover control type (Figure 1 - Table 6.5.1.1.3 High-Limit Shutoff Control Settings for Air Economizers).<sup>883</sup>

**Figure 1 – Baseline ASHRAE High-Limit Shutoff Control Settings**

**TABLE 6.5.1.1.3 High-Limit Shutoff Control Settings for Air Economizers<sup>b</sup>**

Control Type	Allowed Only in Climate Zone at Listed Setpoint	Required High-Limit Setpoints (Economizer Off When):	
		Equation	Description
Fixed dry-bulb temperature	1b, 2b, 3b, 3c, 4b, 4c, 5b, 5c, 6b, 7, 8	$T_{OA} > 75^{\circ}\text{F}$	Outdoor air temperature exceeds 75°F
	5a, 6a	$T_{OA} > 70^{\circ}\text{F}$	Outdoor air temperature exceeds 70°F
	1a, 2a, 3a, 4a,	$T_{OA} > 65^{\circ}\text{F}$	Outdoor air temperature exceeds 65°F
Differential dry-bulb temperature	1b, 2b, 3b, 3c, 4b, 4c, 5a, 5b, 5c, 6a, 6b, 7, 8	$T_{OA} > T_{RA}$	Outdoor air temperature exceeds return air temperature
Fixed enthalpy with fixed dry-bulb temperature	All	$h_{OA} > 28 \text{ Btu/lb}^a$ or $T_{OA} > 75^{\circ}\text{F}$	Outdoor air enthalpy exceeds 28 Btu/lb <sup>a</sup> of dry air <sup>a</sup> or outdoor air temperature exceeds 75°F
Differential enthalpy with fixed dry-bulb temperature	All	$h_{OA} > h_{RA}$ or $T_{OA} > 75^{\circ}\text{F}$	Outdoor air enthalpy exceeds return air enthalpy or outdoor air temperature exceeds 75°F

a. At altitudes substantially different than sea level, the fixed enthalpy limit shall be set to the enthalpy value at 75°F and 50% RH. As an example, at approximately 6000 ft elevation, the fixed enthalpy limit is approximately 30.7 Btu/lb.  
 b. Devices with selectable rather than adjustable setpoints shall be capable of being set to within 2°F and 2 Btu/lb of the setpoint listed.

**Figure 2 – ASHRAE Climate Zone Map**

**NORMATIVE APPENDIX B  
CLIMATE ZONES FOR U.S. STATES AND COUNTIES**

This normative appendix provides the climate zones for U.S. states and counties. Figure B-1 contains the county-level climate zone map for the United States. Table B-1 lists each state and major counties within the state and shows the climate number and letter for each county listed.

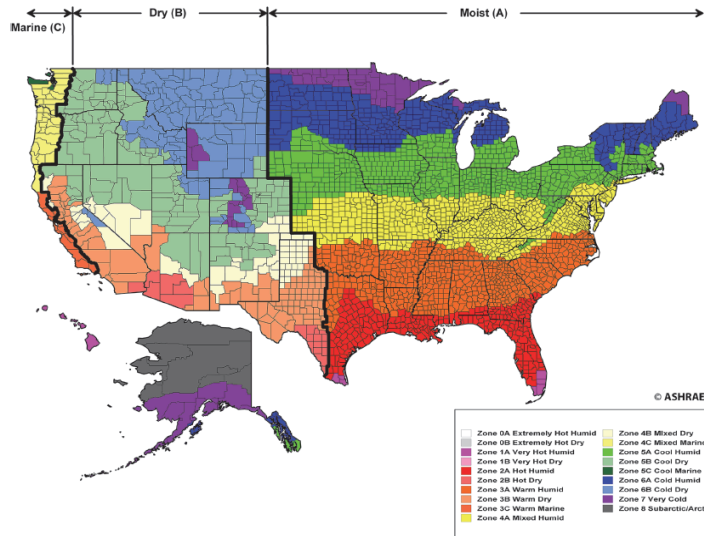

FIGURE B-1 Climate zones for United States counties.

**DEFINITION OF BASELINE EQUIPMENT**

The baseline for this measure is an existing economizer installed on a packaged single zone rooftop HVAC unit. The existing economizer system is currently not operating as designed due to mechanical and/or control problems, and/or is not optimally adjusted.

<sup>883</sup> ASHRAE, Standard 90.1-2013

**DEEMED LIFETIME OF EFFICIENT EQUIPMENT**

The measure life is assumed to be 5 years.<sup>884</sup>

**DEEMED MEASURE COST**

The cost for this measure can vary considerably depending upon the existing condition of the economizer and the work required to achieve the required efficiency levels. Measure cost should be determined on a site-specific basis.

**LOADSHAPE**

Loadshape C03 - Commercial Cooling

**COINCIDENCE FACTOR**

N/A

**Algorithm**

**CALCULATION OF ENERGY SAVINGS**

The savings calculation methodology uses a regression equation to calculate the energy savings for a variety of common situations.<sup>885</sup> The equation variables are limited to the ranges listed; if the actual conditions fall outside of these ranges, custom calculations are required.

**ELECTRIC ENERGY SAVINGS**

$$\Delta kWh = [\text{Baseline Energy Use (kWh/ton)} - \text{Proposed Energy Use (kWh/ton)}] * \text{Cooling Capacity (Tons)}$$

The following equations are used to calculate baseline and proposed electric energy use.<sup>886</sup>

Changeover types: Fixed Dry-Bulb (DB), Dual Temperature Dry-Bulb (DTDB), Dual Temperature Enthalpy (DTEnth), Fixed Enthalpy (Enth), and Analog ABCD Economizers (ABCD).

Electric Energy Use Equations (kWh/ton):

Building Type	Changeover Type	Equation
Assembly	DB	$CZ + CSP*(-2.021) + EL*(-16.362 + OAn*1.665 + OAx*(-3.13))$
	DTDB	$CZ + EL*(-11.5) + OAn*1.635 + OAx*(-2.817)$
	DTEnth	$CZ + EL*(-17.772) + OAn*1.853 + OAx*(-3.044)$
	Enth	$CZ + CSP*(-5.228) + EL*(-17.475) + OAn*1.765 + OAx*(-3.003)$
	ABCD	$CZ + CSP*(-2.234) + EL*(-16.394) + OAn*1.744 + OAx*(-3.01)$
Convenience Store	DB	$CZ + CSP*(-3.982) + EL*(-27.508) + OAn*2.486 + OAx*(-4.684)$
	DTDB	$CZ + EL*(-20.798) + OAn*2.365 + OAx*(-3.773)$
	DTEnth	$CZ + EL*(-30.655) + OAn*2.938 + OAx*(-4.461)$
	Enth	$CZ + CSP*(-8.648) + EL*(-25.678) + OAn*2.092 + OAx*(-3.754)$
	ABCD	$CZ + CSP*(-3.64) + EL*(-24.927) + OAn*2.09 + OAx*(-3.788)$

<sup>884</sup> DEER 2014 (DEER2014 EUT Table D08 v2.05).

<sup>885</sup> For more information on methodology, please refer to workpaper submitted by CLEAResult titled "CLEAResult\_Economizer Repair\_151020\_Finalv2.doc". Note that the original ComEd eQuest models were used in the analysis, rather than the VEIC developed models used elsewhere. VEIC do not consider this a significant issue as adjustments from the ComEd models were focused on calibrating EFLH values, not to overall energy use metrics. We also believe using the ComEd models is likely more conservative. It may be appropriate to update the analysis with the updated models at a later time.

<sup>886</sup> This approach allows the savings estimate to account for the operational attributes of the baseline as well as the proposed case, yielding a better estimate than an approach that assumes a particular baseline or proposed energy use to determine savings.

Building Type	Changeover Type	Equation
Office - Low Rise	DB	$CZ + CSP*(-0.967) + EL*(-6.327) + OAn*2.87 + OAx*(-1.047)$
	DTDB	$CZ + OAn*2.968 + OAx*(-0.943)$
	DTEnth	$CZ + EL*(-9.799) + OAn*3.106 + OAx*(-1.085)$
	Enth	$CZ + CSP*(-2.773) + EL*(-7.392) + OAn*2.941 + OAx*(-0.974)$
	ABCD	$CZ + CSP*(-1.234) + EL*(-7.229) + OAn*2.936 + OAx*(-0.995)$
Religious Facility	DB	$CZ + CSP*(-1.131) + OAn*3.542 + OAx*(-1.01)$
	DTDB	$CZ + EL*(-10.198) + OAn*4.056 + OAx*(-1.279)$
	DTEnth	$CZ + OAn*3.775 + OAx*(-1.031)$
	Enth	$CZ + CSP*(-2.13) + OAn*3.317 + OAx*(-0.629)$
	ABCD	$CZ + CSP*(-0.95) + OAn*3.313 + OAx*(-0.647)$
Restaurant	DB	$CZ + CSP*(-2.243) + EL*(-21.523) + OAx*(-1.909)$
	DTDB	$CZ + EL*(-14.427) + OAn*0.295 + OAx*(-1.451)$
	DTEnth	$CZ + EL*(-25.99) + OAn*0.852 + OAx*(-1.951)$
	Enth	$CZ + CSP*(-4.962) + EL*(-16.868) + OAn*(-0.12) + OAx*(-1.418)$
	ABCD	$CZ + CSP*(-2.115) + EL*(-16.15) + OAn*(-0.125) + OAx*(-1.432)$
Retail - Department Store	DB	$CZ + CSP*(-1.003) + OAn*3.765 + OAx*(-0.938)$
	DTDB	$CZ + OAn*3.688 + OAx*(-0.676)$
	DTEnth	$CZ + OAn*4.081 + OAx*(-1.072)$
	Enth	$CZ + CSP*(-2.545) + OAn*3.725 + OAx*(-0.788)$
	ABCD	$CZ + CSP*(-1.175) + OAn*3.708 + OAx*(-0.809)$
Retail - Strip Mall	DB	$CZ + CSP*(-1.192) + EL*(-5.62) + OAn*3.353 + OAx*(-1.142)$
	DTDB	$CZ + OAn*3.355 + OAx*(-0.915)$
	DTEnth	$CZ + EL*(-9.202) + OAn*3.642 + OAx*(-1.215)$
	Enth	$CZ + CSP*(-2.997) + EL*(-5.938) + OAn*3.312 + OAx*(-0.964)$
	ABCD	$CZ + CSP*(-1.36) + EL*(-5.884) + OAn*3.3 + OAx*(-0.987)$

Where:

- CZ = Climate Zone Coefficient
- = Depends on Building Type and Changover Type (see table below)

Building Type	Changeover Type	Electric Climate Zone Coefficients				
		CZ1 (Rockford)	CZ2 (Chicago)	CZ3 (Springfield)	CZ4 (Belleville)	CZ5 (Marion)
Assembly	DB	874.07	886.73	1043.38	1071.48	1072.20
	DTDB	698.45	711.89	870.13	899.51	903.10
	DTEnth	702.06	715.42	873.43	902.76	906.50
	Enth	851.95	865.43	1020.65	1047.10	1053.32
	ABCD	884.19	897.63	1053.12	1080.58	1086.35
Convenience Store	DB	1739.12	1787.09	2128.78	2206.65	2245.93
	DTDB	1389.28	1436.30	1780.99	1863.45	1904.89
	DTEnth	1398.42	1446.82	1789.71	1869.89	1912.59
	Enth	1643.51	1691.34	2032.83	2112.21	2157.63
	ABCD	1692.80	1740.62	2082.35	2162.73	2207.68
Office - Low Rise	DB	674.06	687.17	899.17	993.84	989.16

Building Type	Changeover Type	Electric Climate Zone Coefficients				
		CZ1 (Rockford)	CZ2 (Chicago)	CZ3 (Springfield)	CZ4 (Belleville)	CZ5 (Marion)
	DTDB	583.62	597.02	811.39	907.61	903.58
	DTEnth	588.94	602.11	816.02	912.49	908.26
	Enth	668.83	682.23	893.61	987.52	986.59
	ABCD	690.27	703.52	915.27	1009.94	1008.59
Religious Facility	DB	613.26	630.50	853.53	923.99	931.74
	DTDB	518.40	535.45	760.76	832.57	840.72
	DTEnth	513.59	531.20	756.26	829.13	837.26
	Enth	576.94	594.17	817.64	888.37	897.18
	ABCD	593.78	611.04	834.69	905.83	914.27
Restaurant	DB	1397.27	1430.45	1763.21	1837.63	1872.18
	DTDB	1191.82	1225.12	1558.32	1633.95	1669.13
	DTEnth	1192.84	1226.77	1559.41	1635.13	1671.11
	Enth	1343.56	1377.52	1710.11	1783.66	1821.67
	ABCD	1373.72	1407.70	1740.43	1814.74	1852.55
Retail - Department Store	DB	717.89	730.07	968.85	1034.78	1035.06
	DTDB	628.83	641.70	883.37	951.09	951.33
	DTEnth	629.35	641.90	882.84	951.33	951.44
	Enth	705.06	717.99	956.42	1020.57	1024.45
	ABCD	728.60	741.47	980.19	1045.30	1048.57
Retail - Strip Mall	DB	800.69	818.68	1070.39	1129.87	1133.84
	DTDB	692.97	711.31	965.63	1026.68	1030.41
	DTEnth	698.12	716.34	970.06	1031.78	1035.72
	Enth	784.54	803.35	1054.37	1112.72	1120.74
	ABCD	810.10	828.86	1080.11	1139.39	1146.95

CSP = Economizer Changeover Setpoint (°F or Btu/lb) (actual in ranges below)

Economizer Control Type		Economizer Changeover Setpoint
Dry-Bulb		60°F – 80°F
Dual Temperature Dry-Bulb		0°F – 5°F delta
Dual Temperature Enthalpy		0 Btu/lb – 5 Btu/lb delta
Enthalpy		18 Btu/lb – 28 Btu/lb
Analog ABCD Economizers	A	73°F
	B	70°F
	C	67°F
	D	63°F
	E	55°F

EL = Integrated Economizer Operation (Economizer Lockout)  
 = 1 for Economizer w/ Integrated Operation (Two Stage Cooling)  
 = 0 for Economizer w/ out Integrated Operation (One Stage Cooling)

OAn = Minimum Outside Air (%OA \* 100)<sup>887</sup>

= Actual. %OA must be between 15% and 70%. If unknown, assume:

- Functional Economizer – 30%
- Nonfunctional Economizer (Damper failed closed) – 15%
- Nonfunctional Economizer (Damper failed open) – 30% (assume Minimum Ventilation (Three Fingers))<sup>888</sup>

Note: the actual integer Oan value (e.g., 30) should be used in the regression algorithm, not the percentage (e.g., 0.3).

OAx = Maximum Outside Air (%)

= Actual. Must be between 15% and 70%. If unknown, assume:

- Functional Economizer – 70%
- Nonfunctional Economizer (Damper failed closed) – 15%
- Nonfunctional Economizer (Damper failed open) – 30% (assume Minimum Ventilation (Three Fingers))

**For example**, a low-rise office building in Rockford (Climate Zone 1) is heated and cooled with a packaged Gas (92 kBtu output) / DX (5 ton) RTU. The RTU is equipped with a fixed dry bulb outside air economizer and is programmed for integrated operation. When the technician inspects the RTU they find that the changeover setpoint is programmed to 62°F, which does not meet ASHRAE economizer high limit shut off air economizer recommendations. After further investigation it is found that the OA damper motor is not operational and is providing 30% outside air.

The technician replaces the damper motor and allow for proper OA damper modulation (30% Min OA & 70% Max OA). They also adjust the fixed dry-bulb changeover setpoint to meet the ASHRAE economizer high limit shut off air economizer recommendation of 70°F.

$\Delta kWh = [\text{Baseline Energy Use (kWh/ton)} - \text{Proposed Energy Use (kWh/ton)}] * \text{Cooling Capacity (tons)}$

Baseline Energy Use (kWh/ton) = Equation for Office Low Rise

$$= CZ + CSP*(-0.967) + EL*(-6.327) + OAn*2.87 + OAx*(-1.047)$$

$$= 674.06 + 62*(-0.967) + 0*(-6.327) + 30*2.87 + 30*(-1.047)$$

$$= 668.8 \text{ kWh/ton}$$

Proposed Energy Use (kWh/ton) = Equation for Office Low Rise

$$= CZ + CSP*(-0.967) + EL*(-6.327) + OAn*2.87 + OAx*(-1.047)$$

$$= 674.06 + 70*(-0.967) + 0*(-6.327) + 30*2.87 + 70*(-1.047)$$

$$= 619.2 \text{ kWh/ton}$$

$\Delta kWh = [668.8 \text{ (kWh/ton)} - 619.2 \text{ (kWh/ton)}] * 5 \text{ tons}$

= 49.6 kWh/ton \* 5 tons

= 248.08 kWh

### SUMMER COINCIDENT PEAK DEMAND SAVINGS

N/A - It is assumed that repair or optimization of the economizer will not typically have a significant impact summer peak demand.

<sup>887</sup> DNV GL, "HVAC Impact Evaluation Final Report WO32 HVAC – Volume 1: Report," California Public Utilities Commission, Energy Division, HVAC Commercial Quality Maintenance (CQM) (1/28/14).

<sup>888</sup> Technician rule of thumb taken from CPUC 'HVAC Impact Evaluation Final Report', WO32, 28Jan 2015, p18.

**FOSSIL FUEL SAVINGS**

$$\Delta\text{Therms} = [\text{Baseline Energy Use (Therms/kBtuh)} - \text{Proposed Energy Use (Therms/kBtuh)}] * \text{Output Heating Capacity (kBtuh)}$$

The following equations are used to calculate baseline and proposed electric energy use.

**Natural Gas Energy Use Equations (therms / kbtu output)**

Building Type	Changeover Type	Equation
Assembly	DB	$CZ + OAn * 0.0853$
	DTDB	$CZ + OAn * 0.0866$
	DTEnth	$CZ + OAn * 0.0866$
	Enth	$CZ + OAn * 0.0855$
	ABCD	$CZ + OAn * 0.0855$
Convenience Store	DB	$CZ + OAn * 0.26$
	DTDB	$CZ + OAn * 0.263$
	DTEnth	$CZ + OAn * 0.263$
	Enth	$CZ + OAn * 0.261$
	ABCD	$CZ + OAn * 0.261$
Office - Low Rise	DB	$CZ + OAn * 0.3$
	DTDB	$CZ + OAn * 0.301$
	DTEnth	$CZ + OAn * 0.301$
	Enth	$CZ + OAn * 0.3$
	ABCD	$CZ + OAn * 0.3$
Religious Facility	DB	$CZ + OAn * 0.35$
	DTDB	$CZ + OAn * 0.348$
	DTEnth	$CZ + OAn * 0.348$
	Enth	$CZ + OAn * 0.349$
	ABCD	$CZ + OAn * 0.349$
Restaurant	DB	$CZ + OAn * 0.0867$
	DTDB	$CZ + OAx * (-0.038) + OAn * OAx * 0.00149$
	DTEnth	$CZ + OAx * (-0.038) + OAn * OAx * 0.00149$
	Enth	$CZ + OAn * 0.0878$
	ABCD	$CZ + OAn * 0.0878$
Retail - Department Store	DB	$CZ + OAn * 0.319$
	DTDB	$CZ + OAn * 0.318$
	DTEnth	$CZ + OAn * 0.318$
	Enth	$CZ + OAn * 0.318$
	ABCD	$CZ + OAn * 0.318$
Retail - Strip Mall	DB	$CZ + OAn * 0.215$
	DTDB	$CZ + OAn * 0.216$
	DTEnth	$CZ + OAn * 0.216$
	Enth	$CZ + OAn * 0.215$
	ABCD	$CZ + OAn * 0.215$

Where:

- CZ = Climate Zone Coefficient
- = Depends on Building Type and Changeover Type (see table below)

Building Type	Changeover Type	Natural Gas Climate Zone Coefficients				
		CZ1 (Rockford)	CZ2 (Chicago)	CZ3 (Springfield)	CZ4 (Belleville)	CZ5 (Marion)
Assembly	DB	-0.03	-0.55	-1.06	-1.28	-1.71
	DTDB	-0.02	-0.57	-1.11	-1.34	-1.79
	DTEnth	-0.02	-0.57	-1.11	-1.34	-1.79
	Enth	-0.03	-0.55	-1.06	-1.29	-1.72
	ABCD	-0.03	-0.55	-1.06	-1.29	-1.72
Convenience Store	DB	2.95	0.50	-1.48	-2.96	-5.56
	DTDB	3.06	0.52	-1.56	-3.11	-5.81
	DTEnth	3.06	0.52	-1.56	-3.11	-5.81
	Enth	2.96	0.50	-1.49	-2.98	-5.59
	ABCD	2.96	0.50	-1.49	-2.98	-5.59
Office - Low Rise	DB	5.83	3.02	0.46	-0.92	-4.13
	DTDB	5.98	3.08	0.41	-1.03	-4.36
	DTEnth	5.98	3.08	0.41	-1.03	-4.36
	Enth	5.85	3.03	0.46	-0.93	-4.16
	ABCD	5.85	3.03	0.46	-0.93	-4.16
Religious Facility	DB	9.23	6.71	3.75	2.40	-0.80
	DTDB	9.41	6.83	3.77	2.39	-0.86
	DTEnth	9.41	6.83	3.77	2.39	-0.86
	Enth	9.25	6.73	3.75	2.40	-0.80
	ABCD	9.25	6.73	3.75	2.40	-0.80
Restaurant	DB	8.30	6.54	4.94	4.00	1.95
	DTDB	10.51	8.71	7.07	6.10	4.00
	DTEnth	10.51	8.71	7.07	6.10	4.00
	Enth	8.28	6.51	4.91	3.96	1.90
	ABCD	8.28	6.51	4.91	3.96	1.90
Retail - Department Store	DB	8.20	5.86	3.19	1.25	-2.59
	DTDB	8.35	5.94	3.18	1.18	-2.75
	DTEnth	8.35	5.94	3.18	1.18	-2.75
	Enth	8.21	5.87	3.18	1.24	-2.61
	ABCD	8.21	5.87	3.18	1.24	-2.61
Retail - Strip Mall	DB	6.40	4.35	2.07	0.49	-2.18
	DTDB	6.51	4.38	2.03	0.39	-2.34
	DTEnth	6.51	4.38	2.03	0.39	-2.34
	Enth	6.41	4.35	2.06	0.48	-2.20
	ABCD	6.41	4.35	2.06	0.48	-2.20

**For example**, a low-rise office building in Rockford (Climate Zone 1) is heated and cooled with a packaged Gas (92 kBtu output) / DX (5 ton) RTU. The RTU is equipped with a fixed dry bulb outside air economizer and is programmed for integrated operation. When the technician inspects the RTU they find that the changeover setpoint is programmed to 62°F, which does not meet ASHRAE economizer high limit shut off air economizer recommendations. After further investigation it is found the OA damper motor is not operational and is providing 30% outside air.

The technician replaces the damper motor and allow for proper OA damper modulation (30% Min OA & 70% Max OA). They also adjust the fixed dry-bulb changeover setpoint to meet the ASHRAE economizer high limit shut off air economizer recommendation of 70°F.

$$\Delta\text{Therms} = [\text{Baseline Energy Use (Therms/kBtuh)} - \text{Proposed Energy Use (Therms/kBtuh)}] * \text{Output Heating Capacity (kBtuh)}$$

$$\text{Baseline Energy Use (Therms/kBtuh)} = \text{Equation for Office Low Rise}$$

$$= \text{CZ} + \text{OAn} * 0.3$$

$$= 5.83 + 30 * 0.3$$

$$= 14.8 \text{ Therms/kBtuh output}$$

$$\text{Proposed Energy Use (Therms/kBtuh)} = \text{Equation for Office Low Rise}$$

$$= \text{CZ} + \text{OAn} * 0.3$$

$$= 5.83 + 30 * 0.3$$

$$= 14.8 \text{ Therms/kBtuh output}$$

$$\Delta\text{Therms} = [14.8(\text{Therms/kBtuh output}) - 14.8(\text{Therms/kBtuh output})] * 92\text{kBtuh output}$$

$$= 0.0(\text{Therms/kBtuh output}) * 92\text{kBtuh output}$$

$$= 0 \text{ Therms}$$

**WATER IMPACT DESCRIPTIONS AND CALCULATION**

N/A

**DEEMED O&M COST ADJUSTMENT CALCULATION**

N/A

**MEASURE CODE: CI-HVC-ECRP-V05-230101**

**REVIEW DEADLINE: 1/1/2026**



## 4.4.36 Multi-Family Space Heating Steam Boiler Averaging Controls

### DESCRIPTION

This measure covers multi-family space heating boiler averaging controls. Temperature sensors are placed in interior spaces to monitor the average temperature of the building. At a minimum, a sensor must be placed at each corner and at one central location. Additionally, a temperature sensor must monitor the outside air temperature. These sensors shall provide data to the averaging controls. The averaging controls will adjust the boiler operation based upon an average of the indoor sensors and the outside air temperature. These controls shall also incorporate a night-time setback capability. Buildings utilizing thermostatic radiator valves, or other modulating control valves or sequences to control the temperature in individual spaces, are not eligible.

This measure was developed to be applicable to the following program types: RF.

### DEFINITION OF EFFICIENT EQUIPMENT

To qualify the boiler(s) must incorporate an averaging control system utilizing at least 4 indoor sensors and 1 outdoor sensor. The controls shall have the capability to incorporate a nighttime setback throughout the building.

### DEFINITION OF BASELINE EQUIPMENT

The baseline is a boiler system without averaging controls or other steam supply modulating controls. Current boiler control system can utilize a single thermostat or aquastat and timer.

### DEEMED LIFETIME OF EFFICIENT EQUIPMENT

The measure life for the domestic hot water boiler(s) is 20 years.<sup>889</sup>

### DEEMED MEASURE COST

As a retrofit measure, the actual installed cost should be used for screening purposes. A deemed retrofit measure cost of \$5,060 can be used if the actual installed cost is unknown.<sup>890</sup>

### LOADSHAPE

N/A

### COINCIDENCE FACTOR

N/A

---

---

### Algorithm

---

---

### CALCULATION OF SAVINGS

#### ELECTRIC ENERGY SAVINGS

N/A

#### SUMMER COINCIDENT PEAK DEMAND SAVINGS

N/A

---

<sup>889</sup> The Brooklyn Union Gas Company, High Efficiency Heating and Water and Controls, Gas Energy Efficiency Program Implementation Plan.

<sup>890</sup> NREL, "Steam Balancing and Tuning for Multifamily Residential Buildings in Chicagoland-Second Year of Data Collection", August 2013.

**FOSSIL FUEL SAVINGS**

$$\Delta\text{Therms} = \text{Capacity} * \text{EFLH} * \text{SF} / 100,000$$

Where:

- Capacity = Boiler gas input size (Btu/h)  
= Actual
- EFLH = Effective Full Load Hours for heating in Existing Buildings are provided in section 4.4. HVAC End Use
- SF = Savings Factor  
= 10.2%,<sup>891</sup> or custom if savings can be substantiated
- 100,000 = converts Btu/h to therm

**For example**, a 1,000,000 btu/h steam boiler in a Mid-Rise Multi-Family building in Chicago has averaging controls installed.

$$\begin{aligned} \Delta\text{Therms} &= 1,000,000 * 1,685 * 0.102 / 100,000 \\ &= 1,719 \text{ therms} \end{aligned}$$

**WATER IMPACT DESCRIPTIONS AND CALCULATION**

N/A

**DEEMED O&M COST ADJUSTMENT CALCULATION**

N/A

**MEASURE CODE: CI-HVC-SBAC-V03-230101**

**REVIEW DEADLINE: 1/1/2028**

---

<sup>891</sup> “Steam Balancing and Tuning for Multifamily Residential Buildings in Chicagoland-Second Year of Data Collection”, NREL, August 2013, states that test buildings with steam balancing measures saved an average of 10.2%. The energy savings estimate assumes additional system balancing through the installation of large capacity air vents on steam main lines and the replacement of radiator vents. This work is assumed to be done in concert with any system being retrofitted with averaging controls.

## 4.4.37 Unitary HVAC Condensing Furnace

### DESCRIPTION

Condensing furnaces recover energy in combustion exhaust flue gasses that would otherwise simply be vented to the atmosphere, making them more efficient than non-condensing furnaces. This measure applies to a constant volume (CV), dedicated outside air system (DOAS), make-up air system (MUAS), or any unitary HVAC system that is utilizing an indirect gas fired process to heat 100% OA to provide ventilation or make-up air to commercial and industrial (C&I) building spaces. The unitary package must contain an indirect gas-fired, warm air furnace section, but the unitary package can be with or without an electric air conditioning section. The unitary package can be either a single package or split system that is applied indoors (non-weatherized) or outdoors (weatherized).

This measure excludes demand control ventilation, condensing unit heaters, and high efficiency (condensing) furnaces with annual fuel utilization efficiency (AFUE) ratings (for furnaces with less than 225,000 Btu/hr input capacity), which are covered by other measures for the C&I sector in the Technical Reference Manual (TRM).<sup>892</sup>

This measure was developed to be applicable to the following program types: TOS, NC. If applied to other program types, the measure savings should be verified.

### DEFINITION OF EFFICIENT EQUIPMENT

To qualify for this measure, the efficient unitary equipment must contain a condensing, warm air furnace with a natural gas thermal efficiency (TE) rating of 90% or higher, or alternatively, the unitary package must have equipment nameplate information for natural gas that identifies a heating output and heating input rating that has an output over input ratio of 0.90 or higher. These ratings must be certified by a recognized testing laboratory in accordance with American National Standards Institute (ANSI) Standard Z21.47 for Gas-Fired Central Furnaces.<sup>893</sup> The furnace must be vented and condensate disposed of in accordance with the equipment manufacturer installation instructions and applicable codes.

### DEFINITION OF BASELINE EQUIPMENT

The baseline equipment is expected to be unitary equipment that contains a non-condensing, warm air furnace with a natural gas thermal efficiency (TE) rating of 81%, or alternatively, the unitary package will have equipment nameplate information for natural gas that identifies a heating output and heating input rating that has an output over input ratio of 0.81. These ratings must be certified by a recognized testing laboratory in accordance with American National Standards Institute (ANSI) Standard Z21.47 for Gas-Fired Central Furnaces. Note, effective January 1, 2023, the Department of Energy (DOE) federal minimum efficiency standard is 81% for  $\geq 225,000$  Btu/hr input capacity furnaces per the Energy Conservation Standard for Commercial Warm Air Furnaces.<sup>894</sup> In the American Society of Heating, Refrigeration and Air-Conditioning Engineers (ASHRAE) Standard 90.1 Energy Standard for Buildings Except Low-Rise Residential Buildings<sup>895</sup> that minimum TE requirement is extended below 225,000 Btu/hr input capacity to require all commercial warm air furnaces and combination warm air furnace/air conditioning units to meet the minimum 81% TE.

---

<sup>892</sup> Illinois Statewide Technical Reference Manual (TRM), Version 12.0 (effective January 1, 2024), 2024.

<sup>893</sup> American National Standards Institute (ANSI), ANSI Z21.47 Standard for Central Gas-Fired Central Furnaces, 2012.

<sup>894</sup> Department of Energy (DOE), Commercial Warm Air Furnace Standard DOE 10 CFR, Part 431, Subpart D – Commercial Warm Air Furnaces, (10 CFR 431.77).

<sup>895</sup> American Society of Heating, Refrigeration and Air-Conditioning Engineers (ASHRAE), ASHRAE Standard 90.1 Energy Standard for Buildings Except Low-Rise Residential Buildings, 2013.<sup>896</sup> Minnesota Department of Commerce, Division of Energy Resources, Field Study of Condensing Heating in Makeup-Air and Mixed-Air Rooftop Units (RTUs), GTI, October 2017

**DEEMED LIFETIME OF EFFICIENT EQUIPMENT**

The expected measure life is assumed to be 15 years<sup>896</sup>, which is consistent with the established TRM measure life for single-package and split system unitary air conditioners, since in colder climates these unitary packages typically contain a gas-fired, warm air furnace section, with an electric air conditioning section.

**DEEMED MEASURE COST**

The actual incremental equipment and installation costs should be used, if available. If not, the incremental cost of \$5.42 per 1000 Btu/hr of output capacity should be used for the condensing furnace equipment (as part of a unitary package) and its installation (including the combustion condensate drainage and disposal system). This incremental cost is from the DOE Technical Support Document for the Notice of Proposed Rulemaking (NOPR) for the Commercial Warm Air Furnace Standard.<sup>897</sup> Per the DOE documentation, it is based on their representative 250,000 Btu/hr input capacity furnace at a 92% TE.

**LOADSHAPE**

Loadshape C23 - Commercial Ventilation

**COINCIDENCE FACTOR**

The coincidence factor is assumed to be 1.0 – that is, building ventilation will always be provided during peak periods.

---

**Algorithm**

---

**CALCULATION OF SAVINGS**

The following methodology provides formulas for estimating gas heating savings associated with condensing furnaces in unitary HVAC packages when applied as a CV, DOAS, MUAS, or any RTU that is indirectly heating 100% outside air (OA). These types of HVAC systems typically run continuously during the HVAC operating schedule to provide building ventilation and maintain indoor air quality or to compensate for exhaust and maintain neutral or slightly positive building pressurization. The algorithm estimates the gas use reduction resulting from utilizing condensing heating of 90% or higher thermal efficiency (TE) in place of the federal minimum TE of 80% (or other user defined baseline TE) for commercial warm air furnaces.

The methodology provides a representative group of operating schedules for the market sector applications highlighted earlier based on DOE commercial reference building models.<sup>898</sup> Heating loads during the operating schedule are determined based on hourly differences between a range of supply air (SA) heated to temperatures and the OA temperature using Typical Meteorological Year (TMYx) weather data.<sup>899</sup> These hourly heating loads are generated for all hours when the OA temperature is below the base temperature of 55 °F for heating in C&I settings per the TRM. To accommodate the variability in heating base temperatures in C&I settings, these hourly heating loads are also generated for base temperatures of 45 °F and 65 °F for heating. The hourly heating loads are then summed for the entire year. The annual heating loads are calculated in this manner for the climate zone 2 weather station (Chicago O’Hare Airport), which is then normalized to its National Centers for Environmental Information (NCEI)<sup>900</sup> 15-year (2006-2020) weather average by multiplying by the heating degree day (HDD) ratio of the NCEI/TRM HDD55 over the TMYx HDD55 (HDD at base temperature of 55 °F), and likewise for the annual heating loads for HDD45 (HDD at base temperature of 45 °F) and HDD65 (HDD at base temperature of 65 °F), using the values in Table 1 and Table 2. Since detailed hourly weather data is not available for all 5 of the TRM climate zone weather stations, the annual heating loads for the other climate zones are determined by multiplying the climate zone 2

<sup>896</sup> Minnesota Department of Commerce, Division of Energy Resources, Field Study of Condensing Heating in Makeup-Air and Mixed-Air Rooftop Units (RTUs), GTI, October 2017

<sup>897</sup> Department of Energy (DOE), Rulemaking for Commercial Warm Air Furnace Standard, Technical Support Document 2015.

<sup>898</sup> Department of Energy (DOE) National Renewable Energy Laboratory, Commercial Reference Building Models of the National Building Stock, 2011.

<sup>899</sup> TMYx climate normal data from year 2007 till 2021; [climate.onebuilding.org](http://climate.onebuilding.org).

<sup>900</sup> National Centers for Environmental Information, U.S Climate Normal 15-year data set from 2006-2020.

annual heating loads by the ratio of the other climate zone NCEI HDD over the climate zone 2 NCEI HDD, using the values in Table 1.

These annual heating loads on a per unit airflow basis are then used in conjunction with the actual airflow of the 100% OA system and its condensing efficiency to calculate the gas heating savings versus the baseline (non-condensing) heating efficiency. This measure results in additional electric use by the unitary HVAC package due to the additional pressure drop of the condensing heat exchanger of the warm air furnace section.

**Table 1. NCEI/TRM HDD Values for All Climate Zones**

Climate Zone - Weather Station/City	NCEI 15 Year Average HDD45 <sup>8</sup>	NCEI 15 Year Average HDD55 <sup>4,8</sup>	NCEI 15 Year Average HDD65 <sup>8</sup>
1 - Rockford AP / Rockford	2419	4171	6414
2 - Chicago O'Hare AP / Chicago	2059	3760	5963
3 - Springfield #2 / Springfield	1743	3296	5368
4 - Belleville SIU RSCH / Belleville	1089	2351	4162
5 - Carbondale Southern IL AP / Marion	1148	2499	4413

**Table 2. TMYx HDD Values for Climate Zone 2**

Climate Zone - Weather Station/City	TMYx HDD45 <sup>7</sup>	TMYx HDD55 <sup>7</sup>	TMYx HDD65 <sup>7</sup>
2 - Chicago O'Hare AP / Chicago	2093	3855	6086

**ELECTRIC ENERGY SAVINGS**

As noted previously, this measure results in additional SA fan electric use by the unitary HVAC system due to the additional pressure drop of the condensing heat exchanger of the warm air furnace section.

$$\Delta kWh = - (t_{FAN} * cfm * \Delta P) / (\eta_{FAN/MOTOR} * 8520)$$

Where:

$t_{FAN}$  = annual fan runtime (hr), refer to Tables 1 through 4

cfm = airflow (cfm), use actual or rated system airflow

$\Delta P$  = incremental pressure drop (inch W.G.), assume 0.15 if actual value not known

$\eta_{FAN/MOTOR}$  = combined fan and motor efficiency, assume 0.60 if actual value not known

8520 = conversion factor (fan horsepower – HP – calculation constant of 6356 for standard air conditions adjusted by 1 HP = 0.746 kW, or 6356/ 0.746 = 8520 for this kW calculation)

**SUMMER COINCIDENT PEAK DEMAND SAVINGS**

The additional SA fan electric use by the unitary HVAC system will typically result in a modest electric demand increase.

$$\Delta kW = (\Delta kWh / t_{FAN}) * CF$$

Where:

$$CF = 1.0$$

**For example**, for a “big box” retail store operating 24 hours a day and 7 days a week (8760 hours per year) with a 5000 cfm DOAS that has an incremental pressure drop of 0.15 inch W.G. and a combined fan and motor efficiency of 0.6 has annual kWh savings of:

$$\begin{aligned} \Delta kWh &= - (t_{FAN} * cfm * \Delta P) / (\eta_{FAN/MOTOR} * 8520) \\ &= - (8760 * 5000 * 0.15) / (0.6 * 8520) \\ &= - 1285 \text{ kWh} \\ \Delta kW &= (\Delta kWh / t_{FAN}) * CF \\ &= (- 1285 / 8760) * 1.0 \\ &= - 0.15 \text{ kW} \end{aligned}$$

### FOSSIL FUEL SAVINGS

$$\Delta \text{Therms} = [Q_{OA} * cfm * (1/TE_{NC} - 1/TE_C)] / 100,000$$

Where:

$$Q_{OA} = \text{annual outside air (OA) heating load per cfm of OA (Btu/cfm)}$$

First, select the most representative operating schedule for the application from among the four (4) scenarios listed below and its set of three (3) applicable tables. Second, select the table in that set with the most representative HDD base temperature – the base temperature for OA below which heating is required. If that base temperature is not readily determined, select the TRM default base temperature of 55 °F (HDD55) for heating in C&I settings. Third, select the climate zone within that table. Fourth, select an appropriate heated to supply air (SA) temperature within that table. Use the resulting  $Q_{OA}$  value, with linear interpolation allowed between SA temperatures.

The four (4) scenarios available are indicative of the following building applications and operating schedules:

1. 24 hour a day and 7 day a week (24/7) operation, with HVAC operating schedule of 8760 hours per year, typical of large retail stores with DOAS, hotel/multifamily buildings with corridor MUAS, and healthcare facilities with DOAS. Use Table 3 through Table 5.
2. 6:00 AM to 1:00 AM everyday operation, with HVAC operating schedule of 7300 hours per year, typical of full service and quick service restaurants with kitchen MUAS. Use Table 6 through Table 8.
3. 7:00 AM to 9:00 PM Monday-Friday, 7:00 AM to 10:00 PM Saturday, and 9:00 AM to 7:00 PM Sunday operations, with HVAC operating schedule of 5266 hours per year, typical of non-24/7 retail stores with DOAS. Use Table 9 through Table 11.
4. 7:00 AM to 9:00 PM Monday-Friday operation, with HVAC operating schedule of 3911 hours per year, typical of school buildings with DOAS. Use Table 12 through Table 14.

$$TE_{NC} = \text{non-condensing thermal efficiency (TE), use federal minimum TE of 81\% (0.81) or actual TE if known}$$

$$TE_C = \text{condensing thermal efficiency (TE), use actual TE or if unknown assume 90\% (0.90)}$$

100,000 = conversion factor (1 therm = 100,000 Btu)

**Continuing the previous example:** for a climate zone 2 (Chicago O'Hare AP / Chicago) application using a 90% TE condensing DOAS with a supply air temperature from the DOAS of 95 °F:

$$\begin{aligned} \Delta\text{Therms} &= [Q_{\text{OA}} * \text{cfm} * (1/\text{TE}_{\text{NC}} - 1/\text{TE}_{\text{C}})] / 100,000 \\ &= 307,374 * 5,000 * (1/0.81 - 1/0.90) / 100,000 \\ &= 1,897 \text{ therms} \end{aligned}$$

8760 Hour Annual Operation Scenario

**Table 3. 8760 Hour Annual Operation Scenario for HDD45**

Supply Air Fan Runtime = 8760 Hours	Q <sub>oa</sub> (Annual Btu/cfm) At Supply Air Temperature Of			
	Climate Zone - Weather Station/City	75°F	85°F	95°F
1 - Rockford AP / Rockford	200,876	246,935	292,995	339,054
2 - Chicago O'Hare AP / Chicago	171,021	210,235	249,449	288,663
3 - Springfield #2 / Springfield	144,713	177,895	211,076	244,258
4 - Belleville SIU RSCH / Belleville	90,394	111,120	131,847	152,574
5 - Carbondale Southern IL AP / Marion	95,368	117,235	139,102	160,970

**Table 4. 8760 Hour Annual Operation Scenario for HDD55**

Supply Air Fan Runtime = 8760 Hours	Q <sub>oa</sub> (Annual Btu/cfm) At Supply Air Temperature Of			
	Climate Zone - Weather Station/City	75°F	85°F	95°F
1 - Rockford AP / Rockford	229,235	285,134	341,034	396,933
2 - Chicago O'Hare AP / Chicago	206,610	256,992	307,374	357,756
3 - Springfield #2 / Springfield	181,126	225,294	269,462	313,630
4 - Belleville SIU RSCH / Belleville	129,220	160,730	192,240	223,751
5 - Carbondale Southern IL AP / Marion	137,337	170,826	204,316	237,806

**Table 5. 8760 Hour Annual Operation Scenario for HDD65**

Supply Air Fan Runtime = 8760 Hours	Q <sub>oa</sub> (Annual Btu/cfm) At Supply Air Temperature Of			
	Climate Zone - Weather Station/City	75°F	85°F	95°F
1 - Rockford AP / Rockford	249,288	321,098	392,909	464,719
2 - Chicago O'Hare AP / Chicago	231,766	298,529	365,292	432,055
3 - Springfield #2 / Springfield	208,624	268,721	328,818	388,914
4 - Belleville SIU RSCH / Belleville	161,761	208,358	254,955	301,553
5 - Carbondale Southern IL AP / Marion	171,517	220,924	270,332	319,739

7300 Hour Annual Operation Scenario

**Table 6. 7300 Hour Annual Operation Scenario for HDD45**

Supply Air Fan Runtime = 7300 Hours	Q <sub>oa</sub> (Annual Btu/cfm) At Supply Air Temperature Of			
	Climate Zone -Weather Station/City	75°F	85°F	95°F
1 - Rockford AP / Rockford	170,393	207,917	245,441	282,965
2 - Chicago O'Hare AP / Chicago	145,069	177,016	208,963	240,910
3 - Springfield #2 / Springfield	122,753	149,785	176,818	203,851
4 - Belleville SIU RSCH / Belleville	76,677	93,562	110,448	127,333
5 - Carbondale Southern IL AP / Marion	80,896	98,711	116,526	134,341

**Table 7. 7300 Hour Annual Operation Scenario for HDD55**

Supply Air Fan Runtime = 7300 Hours	Q <sub>oa</sub> (Annual Btu/cfm) At Supply Air Temperature Of			
	Climate Zone -Weather Station/City	75°F	85°F	95°F
1 - Rockford AP / Rockford	184,019	229,029	274,038	319,047
2 - Chicago O'Hare AP / Chicago	165,857	206,423	246,990	287,557
3 - Springfield #2 / Springfield	145,400	180,963	216,526	252,090
4 - Belleville SIU RSCH / Belleville	103,732	129,103	154,475	179,847
5 - Carbondale Southern IL AP / Marion	110,248	137,213	164,178	191,144

**Table 8. 7300 Hour Annual Operation Scenario for HDD65**

Supply Air Fan Runtime = 7300 Hours	Q <sub>oa</sub> (Annual Btu/cfm) At Supply Air Temperature Of			
	Climate Zone -Weather Station/City	75°F	85°F	95°F
1 - Rockford AP / Rockford	199,927	257,510	315,093	372,675
2 - Chicago O'Hare AP / Chicago	185,875	239,410	292,946	346,481
3 - Springfield #2 / Springfield	167,315	215,505	263,695	311,885
4 - Belleville SIU RSCH / Belleville	129,731	167,096	204,461	241,826
5 - Carbondale Southern IL AP / Marion	137,555	177,174	216,792	256,411

5266 Hour Annual Operation Scenario

**Table 9. 5266 Hour Annual Operation Scenario for HDD45**

Supply Air Fan Runtime = 5266 Hours	Q <sub>oa</sub> (Annual Btu/cfm) At Supply Air Temperature Of			
	Climate Zone -Weather Station/City	75°F	85°F	95°F
1 - Rockford AP / Rockford	116,847	142,840	168,834	194,827
2 - Chicago O'Hare AP / Chicago	99,481	121,611	143,742	165,872
3 - Springfield #2 / Springfield	84,178	102,904	121,630	140,355
4 - Belleville SIU RSCH / Belleville	52,581	64,278	75,975	87,672
5 - Carbondale Southern IL AP / Marion	55,474	67,815	80,156	92,496

**Table 10. 5266 Hour Annual Operation Scenario for HDD55**

Supply Air Fan Runtime = 5266 Hours	Q <sub>oa</sub> (Annual Btu/cfm) At Supply Air Temperature Of			
	Climate Zone -Weather Station/City	75°F	85°F	95°F
1 - Rockford AP / Rockford	125,486	156,333	187,181	218,028



Supply Air Fan Runtime = 5266 Hours	Q <sub>oa</sub> (Annual Btu/cfm) At Supply Air Temperature Of			
	75°F	85°F	95°F	105°F
2 - Chicago O'Hare AP / Chicago	113,100	140,903	168,706	196,509
3 - Springfield #2 / Springfield	99,150	123,524	147,897	172,271
4 - Belleville SIU RSCH / Belleville	70,736	88,125	105,513	122,902
5 - Carbondale Southern IL AP / Marion	75,180	93,660	112,141	130,622

**Table 11. 5266 Hour Annual Operation Scenario for HDD65**

Supply Air Fan Runtime = 5266 Hours	Q <sub>oa</sub> (Annual Btu/cfm) At Supply Air Temperature Of				
	Climate Zone -Weather Station/City	75°F	85°F	95°F	105°F
1 - Rockford AP / Rockford		136,447	175,864	215,281	254,697
2 - Chicago O'Hare AP / Chicago		126,857	163,503	200,149	236,795
3 - Springfield #2 / Springfield		114,190	147,177	180,164	213,151
4 - Belleville SIU RSCH / Belleville		88,540	114,117	139,694	165,271
5 - Carbondale Southern IL AP / Marion		93,880	120,999	148,119	175,239

3911 Hour Annual Operation Scenario

**Table 12. 3911 Hour Annual Operation Scenario for HDD45**

Supply Air Fan Runtime = 3911 Hours	Q <sub>oa</sub> (Annual Btu/cfm) At Supply Air Temperature Of				
	Climate Zone -Weather Station/City	75°F	85°F	95°F	105°F
1 - Rockford AP / Rockford		84,156	102,887	121,617	140,348
2 - Chicago O'Hare AP / Chicago		71,649	87,596	103,542	119,489
3 - Springfield #2 / Springfield		60,627	74,121	87,614	101,108
4 - Belleville SIU RSCH / Belleville		37,870	46,299	54,728	63,156
5 - Carbondale Southern IL AP / Marion		39,954	48,847	57,739	66,632

**Table 13. 3911 Hour Annual Operation Scenario for HDD55**

Supply Air Fan Runtime = 3911 Hours	Q <sub>oa</sub> (Annual Btu/cfm) At Supply Air Temperature Of				
	Climate Zone -Weather Station/City	75°F	85°F	95°F	105°F
1 - Rockford AP / Rockford		90,860	113,295	135,729	158,164
2 - Chicago O'Hare AP / Chicago		81,892	102,113	122,333	142,553
3 - Springfield #2 / Springfield		71,792	89,518	107,244	124,970
4 - Belleville SIU RSCH / Belleville		51,218	63,864	76,510	89,157
5 - Carbondale Southern IL AP / Marion		54,435	67,876	81,317	94,757

**Table 14. 3911 Hour Annual Operation Scenario for HDD65**

Supply Air Fan Runtime = 3911 Hours	Q <sub>oa</sub> (Annual Btu/cfm) At Supply Air Temperature Of				
	Climate Zone -Weather Station/City	75°F	85°F	95°F	105°F
1 - Rockford AP / Rockford		99,503	128,516	157,530	186,543
2 - Chicago O'Hare AP / Chicago		92,509	119,483	146,457	173,431
3 - Springfield #2 / Springfield		83,272	107,553	131,834	156,114
4 - Belleville SIU RSCH / Belleville		64,567	83,393	102,220	121,046

Supply Air Fan Runtime = 3911 Hours	Q <sub>oa</sub> (Annual Btu/cfm) At Supply Air Temperature Of			
	75°F	85°F	95°F	105°F
Climate Zone -Weather Station/City				
5 - Carbondale Southern IL AP / Marion	68,461	88,423	108,385	128,347

**WATER IMPACT DESCRIPTIONS AND CALCULATION**

N/A

**DEEMED O&M COST ADJUSTMENT CALCULATION**

The actual incremental annual maintenance costs should be used, if available. If not, the incremental cost of \$0.05 per 1000 Btu/hr of output capacity should be used for maintaining the combustion condensate disposal system yearly. This incremental cost is from the DOE Technical Support Document for the Notice of Proposed Rulemaking (NOPR) for the Commercial Warm Air Furnace Standard. Per the DOE documentation, it is based on their representative 250,000 Btu/hr input capacity furnace at a 92% TE.

**MEASURE CODE: CI-HVC-DSFN-V05-240101**

**REVIEW DEADLINE: 1/1/2027**

## 4.4.38 Covers and Gap Sealers for Room Air Conditioners

### DESCRIPTION

Room air conditioners (window ACs, through-the-wall or sleeve ACs, PTACs or PTHPs) constitute a permanent or semi-permanent penetration through the building's envelope. These units are often poorly installed, resulting in gaps that act like air leakage pathways through the building's envelope. The uncontrolled movement of air across the gaps in the envelope (infiltration) increases the building's winter heating requirements and reduces its overall energy performance.

The heat loss and infiltration can be reduced by installing a rigid or flexible insulated cover on the inside of a room AC. These covers should be maintained by building staff and should remain installed through the heating season. Simple uninsulated cloth covers with no sealing at edges do not qualify for this measure.

There are several types of AC covers available that may be eligible for this measure:

- If the room AC is left in the window or sleeve, a rigid cover that covers the indoor side of the AC unit with foam gaskets to seal the edges may be installed.
- If the room AC is absent or is removed during the heating months, a rigid cover that fits inside the sleeve with foam gaskets along the edges for proper air sealing may be installed.
- Flexible covers that are well insulated and perfectly cover the indoor side of the AC unit may also be eligible for this measure.

This measure was developed to be applicable to the following program types: RF, DI. If applied to other program types, the measure savings should be verified.

### DEFINITION OF EFFICIENT EQUIPMENT

The installed equipment is a rigid cover that fits inside the empty sleeve or completely covers the indoor side of a window AC unit, with foam gaskets sealing the edges. A flexible insulated cover that perfectly covers the indoor side of the unit and seals gaps may also be installed. Covers should remain installed throughout the winter heating season.

### DEFINITION OF BASELINE EQUIPMENT

The baseline equipment is a room AC (window AC, through-the-wall or sleeve AC, PTAC or PTHP) that is poorly installed with gaps around the edges and does not use AC covers or gap sealers during the winter heating months.

### DEEMED LIFETIME OF EFFICIENT EQUIPMENT

The estimated useful life of typical AC covers is 5 years.<sup>901</sup>

### DEEMED MEASURE COST

The measure cost is the full cost of installing AC covers. Actual installation costs (material and labor) should be used if available. In actual costs are unknown, assume material cost of \$24 (flexible covers) up to \$119, depending on size of the AC unit.<sup>902</sup> The install time per unit is 15 to 30 minutes at assumed labor rate of \$20/hour.

### LOADSHAPE

Loadshape C04 – Commercial Electric Heating

### COINCIDENCE FACTOR

N/A

---

<sup>901</sup> New York Standard Approach for Estimating Energy Savings from Energy Efficiency Programs V4, April 2016 (New York TRM).

<sup>902</sup> Cost estimates from customer invoices and vendors. Material costs can be lower for bulk orders.

**Algorithm**

**CALCULATION OF ENERGY SAVINGS**

**ELECTRIC ENERGY SAVINGS**

If the building is electrically heated, electric energy savings are calculated as follows:

$$\Delta kWh = (Q_{infiltration} * 1.08 * (T_{SA} - T_{OA}) * EFLH_{heat}) / (3,412 * COP)$$

Where:

$$Q_{infiltration} = \text{Air infiltration (CFM) due to poor installation of window or through-the-wall AC}^{903}$$

$$= ELA * 0.000645 * (f_s^2 * (T_{SA} - T_{OA}) + f_w^2 * U^2)^{1/2} * 2118.88$$

Where:

ELA = Effective Leakage Area (sq. in.)  
 = Can be collected on site; if unknown, assume 6 sq. in.<sup>904</sup>

0.000645 = Converts square inches to square meters

f<sub>s</sub> = Stack Coefficient  
 = 1/3 \* (9.81 \* Height \* 0.3048 / T<sub>OA</sub>)<sup>0.5</sup>

f<sub>w</sub> = Wind Coefficient  
 = A \* B \* (Height \* 0.3048 / 10)<sup>C</sup>

Where:

9.81 = Acceleration due to gravity (m/s<sup>2</sup>)

Height = Height of the location of the leakage area in feet  
 = Assume 8 ft per floor

0.3048 = Converts feet to meters

T<sub>OA</sub> = Average Outside Air Temperature during heating period.<sup>905</sup>  
 Use values from table below, based on facility location.<sup>906</sup> This figure must be in Kelvin to determine Stack Coefficient (f<sub>s</sub>) and infiltration (Q<sub>infiltration</sub>), but in Fahrenheit to determine energy savings (ΔkWh, ΔTherms).

Zone	T <sub>OA</sub> (°F)	T <sub>OA</sub> (K)
Zone 1 (Rockford)	31.63	272.94
Zone 2 (Chicago)	33.99	274.26
Zone 3 (Springfield)	34.58	274.58
Zone 4 (Belleville)	36.24	275.51
Zone 5 (Marion)	39.07	277.08

<sup>903</sup> Infiltration equation and values for stack and wind coefficient equations from “The Use of Blower Door Data.” Max Sherman, 1998. The equation is adjusted for wall leakage area (i.e. no ceiling or floor leakage).

<sup>904</sup> Average effective leakage area for multi-family building AC units from “There are Holes in Our Walls.” Prepared for Urban Green Council by Steven Winter Associates, April 2011.

<sup>905</sup> “Heating Period” is defined as hours when the TMY3 dry bulb temperature is less than 55°F (balance point).

<sup>906</sup> Based on NREL’s Typical Meteorological Year 3 (TMY3) data for different weather stations.

A, B and C = Constants based on the facility site’s shielding and terrain parameters. Use values from the tables below:<sup>907</sup>

Shielding Class	Shielding Type	Shielding Description	A
1	None	No obstructions or local shielding whatsoever (i.e. isolated building)	0.324
2	Light	Light local shielding with few obstructions (e.g. A few trees or a shed in the vicinity)	0.285
3	Moderate	Moderate local shielding; some obstructions within two house heights (e.g. Thick hedge fence on fence and nearby building)	0.24
4	Heavy	Heavy shielding; obstructions around most of perimeter buildings or trees within five building heights in most directions (e.g. Well developed/dense tract house)	0.185
5	Very Heavy	Very heavy shielding, large obstruction surrounding perimeter within two house heights (e.g. Typical downtown area)	0.102

Terrain Class	Terrain Type	Terrain Description	B	C
1	None	Ocean or other body of water with at least 5 km of unrestricted space	1.3	0.1
2	Light	Flat terrain with some isolated obstacles (e.g. Buildings or trees well separated from each other)	1	0.15
3	Moderate	Rural areas with low buildings, trees etc.	0.85	0.2
4	Heavy	Urban, industrial or forest areas	0.67	0.25
5	Very Heavy	Center of large city (e.g. Manhattan)	0.47	0.35

0.3048 = Converts feet to meters

$T_{SA}$  = Average Indoor Air Temperature during heating period. This figure will need to be in Kelvin to calculate infiltration ( $Q_{infiltration}$ ) and Fahrenheit to calculate energy savings ( $\Delta kWh$ ,  $\Delta Therms$ ).

= Collected on site. If unknown, assume 72°F (295 K). If known, convert °F to K by using the following equation:  $K = (°F + 459.67) * (5/9)$ .

U = Average Wind Speed (m/s) during heating period. Use table below, based on facility location.<sup>908</sup>

Zone	U (m/s)
Zone 1 (Rockford)	4.50
Zone 2 (Chicago)	4.67
Zone 3 (Springfield)	4.60
Zone 4 (Belleville)	3.92
Zone 5 (Marion)	3.07

2118.88 = Converts  $m^3/s$  to CFM

1.08 = Sensible heat transfer constant (Btu/hr.CFM.°F)

<sup>907</sup> Shielding and terrain class descriptions and constants from “The Use of Blower Door Data.” Max Sherman, 1998” and “Wind and Infiltration Interaction for Small Buildings.” MH Sherman and DT Grimsrud, Lawrence Berkley Laboratory, 1982.

<sup>908</sup> Based on TMY3 data, see “Covers for Room AC\_11092016.xls” for more information.

- EFLH<sub>heat</sub> = Equivalent Full Load Hours for heating in Existing Buildings from section 4.4 HVAC End Use<sup>909</sup>
- 3,412 = Converts Btus to kWh
- COP = Coefficient of Performance of the heating unit  
= Collected on site. If unknown assume 2.6 for PTHP<sup>910</sup>

Deemed per-unit savings for the Multi-Family Building type for Shielding Class 3 and Terrain Class 3 are as follows:

Multi-Family - Electric Savings per Unit (kWh/unit)						
Floor	Height	Rockford	Chicago	Springfield	Belleville	Marion
1	8	55.18	53.16	45.70	31.09	25.67
2	16	68.19	65.31	56.17	38.72	32.66
3	24	77.92	74.34	63.96	44.45	37.97
4	32	86.04	81.85	70.44	49.25	42.44
5	40	93.15	88.42	76.11	53.46	46.37
6	48	99.56	94.34	81.22	57.26	49.93
7	56	105.44	99.76	85.90	60.75	53.20
8	64	110.91	104.80	90.25	63.99	56.24
9	72	116.04	109.53	94.33	67.04	59.11
10	80	120.89	114.00	98.19	69.92	61.81
12	96	129.92	122.31	105.36	75.29	66.85
14	112	138.21	129.94	111.95	80.22	71.49
16	128	145.93	137.04	118.08	84.81	75.82
18	144	153.19	143.72	123.84	89.13	79.88
20	160	160.05	150.03	129.29	93.21	83.72
22	176	166.59	156.03	134.47	97.10	87.38
24	192	172.83	161.77	139.42	100.82	90.88
26	208	178.82	167.28	144.18	104.38	94.23
28	224	184.58	172.57	148.75	107.81	97.46
30	240	190.15	177.69	153.17	111.12	100.58

<sup>909</sup> Although in theory the hours should be all hours that infiltration is expected (i.e. all hours <55F), the IL TAC has agreed to use the Equivalent Full Load Hours to keep the savings at a more conservative level.

<sup>910</sup> From IECC 2012 Minimum Efficiency Requirements. For a 1 ton PTHP, COP = 2.9 – (0.026 \* 12,000/1,000).

**For example**, a mid-rise multi-family building located in the moderate terrain class and shielding class of Chicago, has 16 rooms on the 10<sup>th</sup> floor (80 feet high) with PTHPs that get covered with a cover and foam gasket during the heating months. The indoor temperature during the heating months is maintained at 74°F. The air infiltration and the related energy savings from the AC covers and seals are calculated as follows -

For Shielding Class 3 and Terrain Class 3,

A = 0.24, B = 0.85 and C = 0.2

Therefore,

$$f_s = 1/3 * (9.81 \text{ m/s}^2 * 80 \text{ ft} * 0.3048 \text{ m/ft} / 274.26 \text{ K})^{0.5} = 0.3 \text{ m/K}^{1/2} \cdot \text{s}$$

$$f_w = 0.24 * 0.85 * (80 \text{ ft} * 0.3048 \text{ m/ft} / 10 \text{ m})^{0.2} = 0.24$$

Total effective leakage area (ELA) = 16 units \* 6 sq. in. = 96 sq. in.

$$Q_{\text{infiltration}} = \text{ELA} * 0.000645 * (f_s^2 * (T_{\text{SA}} - T_{\text{OA}}) + f_w^2 * U^2)^{1/2} * 2118.88$$

$$= 96 * 0.000645 * (0.3^2 * (296.48 \text{ K} - 274.26 \text{ K}) + 0.24^2 * 4.67^2)^{1/2} * 2118.88$$

$$= 237 \text{ CFM}$$

$$\Delta \text{kWh} = (237 * 1.08 \text{ Btu/hr.CFM.}^\circ\text{F} * (74^\circ\text{F} - 33.99^\circ\text{F}) * 1,782) / (3,412 \text{ Btu/kWh} * 2.6)$$

$$= 2,057 \text{ kWh}$$

### SUMMER COINCIDENT PEAK DEMAND SAVINGS

As the savings occur during the winter season (non-peak), there are no demand savings associated with this measure.

### FOSSIL FUEL SAVINGS

If the building is heated with gas, the natural gas savings are calculated as follows:

$$\Delta \text{Therms} = (Q_{\text{infiltration}} * 1.08 \text{ Btu/hr.CFM.}^\circ\text{F} * (T_{\text{SA}} - T_{\text{OA}}) * \text{EFLH}_{\text{heat}}) / (100,000 \text{ Btu/therm} * \eta)$$

Where,

$\eta$  = Efficiency of heating equipment.

= Collected on site. If unknown, assume 80%<sup>911</sup>.

100,000 = Converts Btus to therms

Other factors as defined above

Deemed per-unit savings per unit for the Multi-Family Building type for Shielding Class 3 and Terrain Class 3 are as follows:

Multi-Family - Gas Savings per Unit (Therms/Unit)						
Floor	Height	Rockford	Chicago	Springfield	Belleville	Marion
1	8	6.12	5.90	5.07	3.45	2.85
2	16	7.56	7.24	6.23	4.29	3.62
3	24	8.64	8.24	7.09	4.93	4.21
4	32	9.54	9.08	7.81	5.46	4.71
5	40	10.33	9.81	8.44	5.93	5.14
6	48	11.04	10.46	9.01	6.35	5.54
7	56	11.69	11.06	9.53	6.74	5.90
8	64	12.30	11.62	10.01	7.10	6.24
9	72	12.87	12.15	10.46	7.43	6.55
10	80	13.41	12.64	10.89	7.75	6.85
12	96	14.41	13.56	11.68	8.35	7.41

<sup>911</sup> Energy Independence and Security Act of 2007 – averaged for hot water and steam boilers.

Multi-Family - Gas Savings per Unit (Therms/Unit)						
Floor	Height	Rockford	Chicago	Springfield	Belleville	Marion
14	112	15.33	14.41	12.41	8.90	7.93
16	128	16.18	15.20	13.09	9.40	8.41
18	144	16.99	15.94	13.73	9.88	8.86
20	160	17.75	16.64	14.34	10.34	9.28
22	176	18.47	17.30	14.91	10.77	9.69
24	192	19.16	17.94	15.46	11.18	10.08
26	208	19.83	18.55	15.99	11.57	10.45
28	224	20.47	19.14	16.50	11.96	10.81
30	240	21.09	19.70	16.98	12.32	11.15

**For example**, a gas-heated mid-rise multi-family building located in the moderate terrain class and shielding class of Chicago, has 16 rooms on the 10<sup>th</sup> floor (80 feet high) with room air conditioners that get covered with an AC cover and foam gasket during the heating months. The indoor temperature during the heating months is maintained at 74°F. The air infiltration and the related therm savings from the AC covers and seals are calculated as follows:

For Shielding Class 3 and Terrain Class 3,

A = 0.24, B = 0.85 and C = 0.2

Therefore,

$$f_s = 1/3 * (9.81 \text{ m/s}^2 * 80 \text{ ft} * 0.3048 \text{ m/ft} / 274.26 \text{ K})^{0.5} = 0.3 \text{ m/K}^{1/2} \cdot \text{s}$$

$$f_w = 0.24 * 0.85 * (80 \text{ ft} * 0.3048 \text{ m/ft} / 10 \text{ m})^{0.2} = 0.24$$

Total effective leakage area (ELA) = 16 units \* 6 sq.in = 96 sq. in

$$Q_{\text{infiltration}} = \text{ELA} * 0.000645 * (f_s^2 * (T_{SA} - T_{OA}) + f_w^2 * U^2)^{1/2} * 2118.88$$

$$= 96 * 0.000645 * (0.3^2 * (296.48 \text{ K} - 274.26 \text{ K}) + 0.24^2 * 4.67^2)^{1/2} * 2118.88$$

$$= 237 \text{ CFM}$$

$$\Delta \text{Therms} = (237 * 1.08 \text{ Btu/hr.CFM.}^\circ\text{F} * (74^\circ\text{F} - 33.99^\circ\text{F}) * 1,782) / (100,000 \text{ Btu/therm} * 80\%)$$

$$= 228 \text{ therms}$$

**WATER AND OTHER NON-ENERGY IMPACT DESCRIPTIONS AND CALCULATION**

N/A

**DEEMED O&M COST ADJUSTMENT CALCULATION**

N/A

**MEASURE CODE: CI-HVC-CRAC-V03-230101**

**REVIEW DEADLINE: 1/1/2027**



#### 4.4.39 High Temperature Heating and Ventilation (HTHV) Direct Fired Heater

##### **DESCRIPTION**

This measure applies to 100% outside air, high temperature heating and ventilation (HTHV) direct fired gas heaters. These units replace unit heaters (indirect gas fired or steam coil) or rooftop units in warehouses which suffer from extreme temperature stratification, minimal controls, and reduced heating efficiencies.

Warehouses have high ceilings (~30 ft high) and suffer from stratification of air. The warm air rises and remains near the roof which keeps the thermostat from reaching its desired setpoint. This increases the run hours of the heating unit and causes discomfort among the occupants. The HTHV units have high pressure fans that direct high temperature and high velocity air towards the floor to help minimize temperature stratification. On average, a 30 ft high warehouse could reduce its linear stratification from 0.53°F/ft to 0.13°F/ft, thus maintaining a more uniform temperature in the room and reducing the operating hours of the heating unit.

Since the HTHV units are direct fired, they also have improved efficiencies of 92% compared to 80% for a typical indirect fired unit heater or rooftop unit. They transfer the latent heat of the flue gases into the space instead of venting it out.

This measure only applies to high ceiling warehouses that do not have any other destratification technologies installed (e.g., destratification fans, air rotation units). New HTHV units must be the warehouse's primary heat source.

This measure was developed to be applicable to the following program types: RF, TOS, NC. If applied to other program types, the measure savings should be verified.

##### **DEFINITION OF EFFICIENT EQUIPMENT**

The efficient equipment must be a 100% outside air, HTHV direct fired gas heater with a discharge temperature greater than or equal to 150°F, a temperature rise that is greater than or equal to 140°F, and an efficiency exceeding 92%.

##### **DEFINITION OF BASELINE EQUIPMENT**

The baseline equipment must be an indirect fired gas, steam unit heater, or a rooftop unit used as the primary space heating source. Warehouses with existing destratification technologies (high volume, low speed fans or air turnover units) do not qualify for this measure.

##### **DEEMED LIFETIME OF EFFICIENT EQUIPMENT**

The measure life is assumed to be 15 years.<sup>912</sup>

##### **DEEMED MEASURE COST**

The measure cost should be based on a contractor's evaluation of the project scope and may vary significantly on a project-to-project basis. If unknown, for early replacement or retrofit projects, assume \$14.50/MBtuh (material cost for an HTHV unit) or \$26/MBtuh (sum of material and installation cost).<sup>913</sup>

The incremental measure cost, assuming a baseline of standard efficiency unit heaters, is \$7.43/MBtuh (material cost).<sup>914</sup>

---

<sup>912</sup> Based on "Field Demonstration of High Efficiency Gas Heaters", prepared for Better Buildings Alliance, US. DOE, Jim Young, Navigant Consulting, 2014.

<sup>913</sup> Average costs from CLEAResult's evaluation of 9 different projects in the Chicagoland area.

<sup>914</sup> Based on data collected in "Field Demonstration of High Efficiency Gas Heaters", prepared for Better Buildings Alliance, US. DOE, Jim Young, Navigant Consulting, 2014.

**LOADSHAPE**

Loadshape C04: Commercial Electric Heating

**COINCIDENCE FACTOR**

Assumed to be 0.

**Algorithm**

**CALCULATION OF ENERGY SAVINGS**

**ELECTRIC ENERGY SAVINGS**

HTHV units may increase the facility’s electric energy consumption due to high pressure motors that supply air at higher velocity.

$$\Delta kWh = - (kWh/HDD) * HDD$$

Where:

- kWh/HDD = increase in electric energy consumption due to HTHV fan motor  
= 1.04<sup>915</sup>
- HDD = heating degree days

Zone	City	HDD55 <sup>916</sup>	ΔkWh
1	Rockford	4,272	(4,443)
2	Chicago	4,029	(4,190)
3	Springfield	3,406	(3,542)
4	Belleville	2,515	(2,616)
5	Marion	2,546	(2,648)

Although HTHV fan motors have a higher power draw, they also result in decreased heating equipment operating time, potentially offsetting some of the increase in electrical energy consumption. Therefore, if replacing heating equipment other than unit heaters, a custom evaluation may be necessary to determine if there is an increase in electrical energy consumption.

**SUMMER COINCIDENT PEAK DEMAND SAVINGS**

Since HTHV units operate during the winter (non-peak) season, there are no demand savings associated with this measure.

**FOSSIL FUEL SAVINGS**

Custom calculation below. Otherwise, use a deemed savings factor from the table that follows.

$$\Delta Therms = (FLH_{base} * Cap_{base} / (\eta_{base} * 100)) - (FLH_{eff} * Cap_{eff} / (\eta_{eff} * 100))$$

Where:

- FLH<sub>base</sub> = LF<sub>base</sub> \* Hours
- FLH<sub>eff</sub> = LF<sub>eff</sub> \* Hours

<sup>915</sup> Based on data collected in “Field Demonstration of High Efficiency Gas Heaters”, prepared for Better Buildings Alliance, US. DOE, Jim Young, Navigant Consulting, 2014. This study replaced four standard unit heaters with HTHV units, and the electrical energy increased from 0.40 kWh/HDD to 1.44 kWh/HDD. Therefore, savings are assumed to be 1.04 kWh /HDD.

<sup>916</sup> 30-year normals from the National Climactic Data Center (NCDC), assuming base temperature 55.

Hours = Annual operating hours of the unit, calculated as total number of hours when outside air temperature is less than 55°F. This can be adjusted based on the facility’s occupancy schedule.

LF<sub>base</sub> = load factor of baseline unit heater  
=  $(Q_{inf,base} + Q_{w,base} + Q_{r,base}) / (Cap_{base} * 100)$

LF<sub>eff</sub> = load factor of HTHV heater  
=  $(Q_{inf,eff} + Q_{w,eff} + Q_{r,eff}) / (Cap_{eff} * 100)$

Cap<sub>base</sub> = existing heating unit input capacity (MBtuh)  
= can be collected on site, or assumed to be the same as HTHV unit capacity, Cap<sub>eff</sub>

Cap<sub>eff</sub> = HTHV unit input capacity (MBtuh)  
= can be collected on site or from specification sheets

η<sub>base</sub> = efficiency of existing heating unit  
= collected from equipment nameplate or assumed as 70% for steam unit heaters, 80% for gas fired unit heaters, and 84% for rooftop units<sup>917</sup>

η<sub>eff</sub> = efficiency of HTHV unit  
= collected from equipment nameplate or assumed as 92%

100 = converts MBtu to therms

See following table for savings inputs.

---

<sup>917</sup> Efficiency of existing systems assumed from ASHRAE 90.1 – 2010 and manufacturer’s specification sheets for various equipment. Steam unit heaters have a lower efficiency due to steam distribution losses.

Parameter	Existing Unit	Proposed (Efficient) Unit
<b>Temperatures</b>		
Setpoint Temperature (°F):	$T_{\text{setpoint}}$ = collected on site, or assumed as 65°F	
Ceiling Temperature <sup>918</sup> (°F):	Either collected on site when the existing unit is in operation with an infrared gun or assumed as: $T_{\text{c,base}} = T_{\text{setpoint}} + 0.53^{\circ}\text{F}/\text{ft} * \text{Height}$	Either collected on site when the proposed unit is in operation with an infrared gun or assumed as: $T_{\text{c,eff}} = T_{\text{setpoint}} + 2 \text{ to } 4^{\circ}\text{F}$
Average Room Temperature (°F):	$T_{\text{r,base}} = (T_{\text{setpoint}} + T_{\text{c,base}}) / 2$	$T_{\text{r,eff}} = (T_{\text{setpoint}} + T_{\text{c,eff}}) / 2$
Outside Air Temperature (°F):	$T_{\text{OA}}$ from local weather data <sup>919</sup>	
<b>Heat Loads</b>		
Infiltration Load <sup>920</sup> :	$Q_{\text{inf,base}} = 0.04\text{CFM}/\text{ft}^2 * (\text{Wall Surface Area} + \text{Roof Surface Area}) * 1.08 * (T_{\text{r,base}} - T_{\text{OA}})$	$Q_{\text{inf,eff}} = 0.04\text{CFM}/\text{ft}^2 * (\text{Wall Surface Area} + \text{Roof Surface Area}) * 1.08 * (T_{\text{r,eff}} - T_{\text{OA}})$
Wall Conduction Load <sup>921</sup> :	$Q_{\text{w,base}} = 1/\text{R-value}_{\text{wall}} * (\text{Wall Surface Area} * 1.08 * (T_{\text{r,base}} - T_{\text{OA}}))$ Where: R-value <sub>wall</sub> = the insulation value of the wall. It can be collected on site or assumed as R-15.	$Q_{\text{w,eff}} = 1/\text{R-value}_{\text{wall}} * (\text{Wall Surface Area} * 1.08 * (T_{\text{r,eff}} - T_{\text{OA}}))$ Where: R-value <sub>wall</sub> = the insulation value of the wall. It can be collected on site or assumed as R-15.
Roof Conduction Load:	$Q_{\text{r,base}} = 1/\text{R-value}_{\text{roof}} * (\text{Roof Surface Area} * 1.08 * (T_{\text{r,base}} - T_{\text{OA}}))$ Where: R-value <sub>roof</sub> = the insulation value of the roof. It can be collected on site or assumed as R-20.	$Q_{\text{r,eff}} = 1/\text{R-value}_{\text{roof}} * (\text{Roof Surface Area} * 1.08 * (T_{\text{r,eff}} - T_{\text{OA}}))$ Where: R-value <sub>roof</sub> = the insulation value of the roof. It can be collected on site or assumed as R-20.
<b>Surface Areas</b>		
Roof Surface Area:	Collected on site or assumed as: = facility area in ft <sup>2</sup> If facility area is unknown, assume facility area <sup>922</sup> : = 41.4 ft <sup>2</sup> /MBtuh * Cap <sub>eff</sub>	
Wall Surface Area:	Collected on site or assumed as: = (Height * Length + Height * Width) * 2 Where: Length, height, and width (feet) of the facility can be collected on site. If unknown, assume: Length = Width = (Facility Area) <sup>1/2</sup> and Height = 25 ft If facility area is unknown, assume facility area: = 41.4 ft <sup>2</sup> /MBtuh * Cap <sub>eff</sub>	

The default values from the table above were used to calculate the deemed savings values in the following table. Savings are provided for various rated input capacity ranges and weather stations.

<sup>918</sup> Baseline stratification rate is based on data collected in “Field Demonstration of High Efficiency Gas Heaters”, prepared for Better Buildings Alliance, US. DOE, Jim Young, Navigant Consulting, 2014. The study also verifies that the proposed ceiling temperature can be maintained within 2-4°F of the setpoint.

<sup>919</sup> Use Typical Meteorological Year (TMY3) data from NREL.

<sup>920</sup> Typical infiltration rate assumed from Infiltration Modeling Guidelines for Commercial Building Energy Analysis, prepared for US. DOE by Pacific Northwestern National Laboratory, 2009.

<sup>921</sup> Roof and Wall Insulation R-values are based on ASHRAE 90.1- 2010. (Jim Young 2014) (K. Gowri 2009).

<sup>922</sup> Based on DOE’s Commercial Prototype Modeled Warehouse building (in Chicago), via the Building Energy Codes Program.

Illinois Statewide Technical Reference Manual – 4.4.39 High Temperature Heating and Ventilation (HTHV) Direct Fired Heater

Cap <sub>eff</sub> (MBtu/hr)	Average Cap <sub>eff</sub> (MBtu/hr)	Nearest Weather Station	ΔTherms (Baseline: Steam Fired Unit Heaters )	ΔTherms (Baseline: Gas Fired Unit Heaters)	ΔTherms (Baseline: Rooftop Units)
300 < Cap <sub>eff</sub> ≤ 500	400	Rockford	3,120	1,996	1,620
500 < Cap <sub>eff</sub> ≤ 900	757	Rockford	5,208	3,346	2,725
900 < Cap <sub>eff</sub> ≤ 1,000	950	Rockford	6,280	4,047	3,297
1,000 < Cap <sub>eff</sub> ≤ 1,400	1,200	Rockford	7,656	4,932	4,020
1,400 < Cap <sub>eff</sub> ≤ 1,600	1,499	Rockford	9,249	5,966	4,872
1,600 < Cap <sub>eff</sub> ≤ 2,100	1,850	Rockford	11,100	7,160	5,865
2,100 < Cap <sub>eff</sub> ≤ 2,400	2,200	Rockford	12,914	8,338	6,820
2,400 ≤ Cap <sub>eff</sub>	2,718	Rockford	15,547	10,084	8,236
300 < Cap <sub>eff</sub> ≤ 500	400	Chicago	2,820	1,824	1,488
500 < Cap <sub>eff</sub> ≤ 900	757	Chicago	4,709	3,058	2,506
900 < Cap <sub>eff</sub> ≤ 1,000	950	Chicago	5,681	3,696	3,031
1,000 < Cap <sub>eff</sub> ≤ 1,400	1,200	Chicago	6,924	4,512	3,696
1,400 < Cap <sub>eff</sub> ≤ 1,600	1,499	Chicago	8,364	5,456	4,482
1,600 < Cap <sub>eff</sub> ≤ 2,100	1,850	Chicago	10,046	6,549	5,384
2,100 < Cap <sub>eff</sub> ≤ 2,400	2,200	Chicago	11,682	7,634	6,292
2,400 ≤ Cap <sub>eff</sub>	2,718	Chicago	14,079	9,214	7,583
300 < Cap <sub>eff</sub> ≤ 500	400	Springfield	2,452	1,588	1,300
500 < Cap <sub>eff</sub> ≤ 900	757	Springfield	4,095	2,665	2,188
900 < Cap <sub>eff</sub> ≤ 1,000	950	Springfield	4,950	3,221	2,651
1,000 < Cap <sub>eff</sub> ≤ 1,400	1,200	Springfield	6,024	3,936	3,240
1,400 < Cap <sub>eff</sub> ≤ 1,600	1,499	Springfield	7,285	4,767	3,912
1,600 < Cap <sub>eff</sub> ≤ 2,100	1,850	Springfield	8,732	5,717	4,718
2,100 < Cap <sub>eff</sub> ≤ 2,400	2,200	Springfield	10,164	6,666	5,500
2,400 ≤ Cap <sub>eff</sub>	2,718	Springfield	12,258	8,045	6,632
300 < Cap <sub>eff</sub> ≤ 500	400	Belleville	2,456	1,604	1,320
500 < Cap <sub>eff</sub> ≤ 900	757	Belleville	4,103	2,687	2,218
900 < Cap <sub>eff</sub> ≤ 1,000	950	Belleville	4,950	3,249	2,689
1,000 < Cap <sub>eff</sub> ≤ 1,400	1,200	Belleville	6,036	3,972	3,276
1,400 < Cap <sub>eff</sub> ≤ 1,600	1,499	Belleville	7,300	4,812	3,972
1,600 < Cap <sub>eff</sub> ≤ 2,100	1,850	Belleville	8,751	5,772	4,773
2,100 < Cap <sub>eff</sub> ≤ 2,400	2,200	Belleville	10,186	6,732	5,566
2,400 ≤ Cap <sub>eff</sub>	2,718	Belleville	12,285	8,127	6,713
300 < Cap <sub>eff</sub> ≤ 500	400	Marion	2,180	1,444	1,200
500 < Cap <sub>eff</sub> ≤ 900	757	Marion	3,649	2,430	2,021
900 < Cap <sub>eff</sub> ≤ 1,000	950	Marion	4,408	2,936	2,442
1,000 < Cap <sub>eff</sub> ≤ 1,400	1,200	Marion	5,364	3,576	2,988
1,400 < Cap <sub>eff</sub> ≤ 1,600	1,499	Marion	6,491	4,332	3,613
1,600 < Cap <sub>eff</sub> ≤ 2,100	1,850	Marion	7,789	5,217	4,348
2,100 < Cap <sub>eff</sub> ≤ 2,400	2,200	Marion	9,064	6,072	5,082
2,400 ≤ Cap <sub>eff</sub>	2,718	Marion	10,926	7,339	6,116

**WATER AND OTHER NON-ENERGY IMPACT DESCRIPTIONS AND CALCULATION**

N/A

**DEEMED O&M COST ADJUSTMENT CALCULATION**

N/A

**MEASURE CODE: CI-HVC-HTHV-V02-230101**

**REVIEW DEADLINE: 1/1/2028**

## 4.4.40 Gas High Efficiency Single Package Vertical Air Conditioner

### DESCRIPTION

This measure covers the installation of a single package vertical air conditioner (SPVAC) with a high efficiency gas furnace, referred to here as a through-the-wall (TTW) condensing gas furnace instead of a standard efficiency gas furnace. The primary market served by TTWs are multifamily housing and hospitality in a new construction application. High efficiency gas furnaces achieve savings through the utilization of a sealed, super insulated combustion chamber, more efficient burners, and multiple heat exchangers that remove a significant portion of the waste heat from the flue gases. Because multiple heat exchangers are used to remove waste heat from the escaping flue gases, most of the flue gases condense and must be drained. Management of the acidic condensate is currently a major limiting factor for retrofit application, making the new construction the best initial market point until the industry develops better strategies for condensate management for retrofit applications. Also, TTWs are normally installed at the exterior wall to access outside air to reject heat in the cooling cycle. Placement of TTWs near the exterior might be prohibitive in retrofit applications. Furnaces equipped with ECM fan motors and with above code EER ratings provide an opportunity for additional electric energy savings.

This measure assumes a unit size less than or equal to 65,000 Btu/hr.

This measure was developed to be applicable to the following program types: NC, TOS. If applied to other program types such as RF, the measure savings should be verified via a custom measure.

### DEFINITION OF EFFICIENT EQUIPMENT

To qualify for this measure the installed equipment must be a TTW condensing system with a code minimum 11.0 EER cooling system and a high-efficiency gas furnace with an annual fuel utilization efficiency (AFUE) of 90% or greater.<sup>923</sup> Fan electrical efficiency must exceed the program requirements.

### DEFINITION OF BASELINE EQUIPMENT

Baseline equipment for this measure are units with a cooling system that meets the current code minimum 11.0EER efficiency rating and a heating unit with an AFUE rating of 80% or less.

### DEEMED LIFETIME OF EFFICIENT EQUIPMENT

The expected measure life is assumed to be 16.5 years.<sup>924</sup>

### DEEMED MEASURE COST

The incremental capital cost for this measure depends on efficiency as listed below:<sup>925</sup>

AFUE	Incremental Cost Premium
80%	\$400
90%	\$400
95%	\$500

### LOADSHAPE

Loadshape R08 – Residential Cooling

### COINCIDENCE FACTOR

The summer peak coincidence factor for cooling is provided in two different ways below. The first is used to estimate peak savings during the utility peak hour and is most indicative of actual peak benefits. The second represents the

<sup>923</sup> Electronic Code of Federal Regulations: 10 CFR 431.97, last modified on September 23, 2019.

<sup>924</sup> Average of 15-18 year lifetime estimate made by the Consortium for Energy Efficiency in 2010.

<sup>925</sup> Based on discussion with TTW Manufacturers at AHR 2018 Show in Chicago, IL.

average savings over the defined summer peak period and is presented so that savings can be bid into PJM’s capacity market.

- CF<sub>SSP</sub> = Summer System Peak Coincidence Factor for Central A/C (during utility peak hour)  
= 68%<sup>926</sup>
- CF<sub>PJM</sub> = PJM Summer Peak Coincidence Factor for Central A/C (average during PJM peak period)  
= 46.6%<sup>927</sup>

---



---

**Algorithm**

---



---

**CALCULATION OF ENERGY SAVINGS**

**ELECTRIC ENERGY SAVINGS**

Electric savings come from a high efficiency cooling unit.<sup>928</sup> In some instances, the TTW unit provided by the manufacturer may not have higher efficiency cooling and fan blower motor systems integrated into the TTW design; in these cases, electric energy savings will be zero for those components.

$$\Delta kWh_{EER} = FLH_{cool} * Capacity * (1/EER_{base} - 1/EER_{eff}) / 1000$$

Where:

- FLH<sub>cool</sub> = Full load hours for cooling:<sup>929</sup>

Climate Zone (City based upon)	FLH <sub>cool</sub> (multifamily)
1 (Rockford)	467
2 (Chicago)	506
3 (Springfield)	663
4 (Belleville)	940
5 (Marion)	820
Weighted Average	564

- Capacity = Cooling capacity of the efficient unit in Btu/hr  
= Actual installed
- EER<sub>eff</sub> = Energy efficiency ratio of the efficient equipment  
= Actual installed rating
- EER<sub>base</sub> = Energy efficiency ratio of the baseline equipment<sup>930</sup>  
= 11.0

<sup>926</sup> Based on metering of 24 homes with central AC during PY4 and PY5 in Ameren Illinois service territory.

<sup>927</sup> Based on analysis of Itron eShape data for Missouri, calibrated to Illinois loads, supplied by Ameren. The average AC load over the PJM peak period (1-5pm, M-F, June through August) is divided by the maximum AC load during the year.

<sup>928</sup> If an ECM motor in the packaged system is present, savings should be claimed for this measure by referring to the Residential Furnace Blower Motor measure in the IL TRM.

<sup>929</sup> Full load hours for Chicago, Moline, and Rockford are provided in “Final Evaluation Report: Central Air Conditioning Efficiency Services (CACES), 2010, Navigant Consulting”, p.33. An average FLH/Cooling Degree Day (from NCD) ratio was calculated for these locations and applied to the CDD of the other locations to estimate FLH. There is a county mapping table in Volume 1, Section 3.7 providing the appropriate city to use for each county of Illinois.

<sup>930</sup> Electronic Code of Federal Regulations: 10 CFR 431.97, last modified on September 23, 2019.



**For example**, for a Rockford non-weatherized multifamily unit conditioned by a SPVAC with a 2-ton (24,000 Btu/hr) cooling capacity, a rated EER of 11.0, and an ECM fan blower motor installed.

$$\Delta kWh = [467 * 24,000 * (1/11.0 - 1/13.0) / 1000] = 157 \text{ kWh}$$

**SUMMER COINCIDENT PEAK DEMAND SAVINGS**

$$\Delta kW = CF * Capacity * (1/EER_{base} - 1/EER_{eff}) / 1000$$

Where:

CF<sub>SSP</sub> = Summer System Peak Coincidence Factor for Central A/C (during utility peak hour)  
= 68%<sup>931</sup>

CF<sub>PJM</sub> = PJM Summer Peak Coincidence Factor for Central A/C (average during PJM peak period)  
= 46.6%<sup>932</sup>

**FOSSIL FUEL SAVINGS**

$$\Delta Therms = EFLH_{heat} * Capacity * (AFUE_{eff} - AFUE_{base}) / AFUE_{base} / 100,000$$

Where:

EFLH<sub>heat</sub> = Equivalent Full Load Hours for heating.<sup>933</sup>

Climate Zone (City based upon)	EFLH <sub>heat</sub> (general multifamily)
1 (Rockford)	1,742
2 (Chicago)	1,704
3 (Springfield)	1,498
4 (Belleville)	1,208
5 (Marion)	1,429

Capacity = Nominal heating input capacity furnace size (Btu/hr) for efficient unit  
= Actual

AFUE<sub>eff</sub> = Efficient furnace annual fuel utilization efficiency rating  
= Actual installed rating

AFUE<sub>base</sub> = Baseline furnace annual fuel utilization efficiency rating  
= 80%

100,000 = Btu/Therm

**For example**, for a Chicago non-weatherized multifamily unit heated by an SPVAC with a 40 kBtu/hr capacity and a rated AFUE of 93%.

$$\Delta Therms = 1,704 * 40,000 * [(0.93 - 0.8) / 0.8] / 100,000 = 111 \text{ therms}$$

<sup>931</sup> Based on metering of 24 homes with central AC during PY4 and PY5 in Ameren Illinois service territory.

<sup>932</sup> Based on analysis of Itron eShape data for Missouri, calibrated to Illinois loads, supplied by Ameren. The average AC load over the PJM peak period (1-5pm, M-F, June through August) is divided by the maximum AC load during the year.

<sup>933</sup> See section 4.4 for details.

**WATER AND OTHER NON-ENERGY IMPACT DESCRIPTIONS AND CALCULATION**

N/A

**DEEMED O&M COST ADJUSTMENT CALCULATION**

N/A

**MEASURE CODE: CI-HVC -SPVA-V02-230101**

**REVIEW DEADLINE: 1/1/2027**

#### 4.4.41 Advanced Rooftop Controls (ARC)

##### **DESCRIPTION**

The Advanced Rooftop Controls (ARC) measure installs demand-controlled ventilation with optional supply-fan speed control via a variable-frequency drive to a single-zone, packaged HVAC unit with a functioning integrated economizer already installed. The demand-controlled ventilation modulates the outside air damper based on CO<sub>2</sub> concentration in the conditioned space. The supply-fan speed control options consist of setting the fan speed to 40% in ventilation mode and to 90% in heating and cooling modes, or of setting the fan speed to 40% in ventilation mode, to 75% in 1st stage heating and 1st stage cooling modes, and to 90% in 2nd stage heating and 2nd stage cooling modes. The measure results in fan, cooling, and heating savings compared to a baseline scenario of constant-volume, constant-ventilation operation typical of single-zone, packaged HVAC units. There are several off-the-shelf products available for the packaged HVAC unit market that support these control sequences, and the energy savings potential of these strategies has been studied and reported on.<sup>934</sup>

Demand-controlled ventilation modulates the percentage of outside air that is delivered to a space and its occupants by controlling the position of the outside air damper. The outside air damper is set to the minimum position required for the space and is opened further when CO<sub>2</sub> concentration in the conditioned space increases which indicates an increase in occupancy. The damper also opens to provide 100% outside air cooling (i.e., the unit economizes) when conditions permit. This portion of the measure saves energy by minimizing the energy required to unnecessarily heat and cool outside air. Demand-controlled ventilation can also be combined with the installation of a variable-frequency drive on the supply fan. This drive is used to reduce the speed of the supply fan when the full design airflow is not required. When the unit is only providing ventilation air (i.e., not heating or cooling), the airflow is reduced substantially but not below the required minimum ventilation rate. The flow for heating and cooling can also be reduced a small amount in most cases. Per the fan affinity laws, the reduction in flow correlates to a near cubic reduction in fan power. In these ways, this measure is able to achieve cooling, heating, and fan energy reduction.

This measure is intended for commercial buildings served by single-zone, packaged HVAC units. This measure was developed to be applicable to the following program types: RF, DI.

If applied to other program types, the measure savings should be verified.

##### **DEFINITION OF EFFICIENT EQUIPMENT**

The efficient equipment is a single-zone, packaged HVAC unit (with an existing functional integrated economizer) that has been retrofitted with demand-controlled ventilation controls with optional supply-fan speed control via a variable-frequency drive.

##### **DEFINITION OF BASELINE EQUIPMENT**

The baseline equipment is a single-zone, packaged HVAC unit (with an existing functional integrated economizer) that lacks demand-controlled ventilation controls and lacks supply-fan speed control via a variable-frequency drive.

##### **DEEMED LIFETIME OF EFFICIENT EQUIPMENT**

The deemed measure life is 10 years and based on the estimated life of a CO<sub>2</sub> sensor.<sup>935</sup>

---

<sup>934</sup> Katipamula, S., et al, "Advanced Rooftop Control (ARC) Retrofit: Field-Test Results", Pacific Northwest National Laboratory, July 2013.

<sup>935</sup> During conversations with vendors and Building Automation System (BAS) contractors, it was determined that sensors must be functional for up to 10 years. It is recommended that they are part of a normal preventive maintenance program in which calibration is an important part of extending useful life. Although they are not subject to mechanical failure, they do fall out of tolerance over time.

**DEEMED MEASURE COST**

Actual measure costs should be used if available. If costs are not available, the deemed measure cost below can be used.

**Table 1 – Deemed Measure Cost Details**

Measure	Material Unit (Each)	Material Cost / Unit	Labor Unit (Hours)	Labor Rate/ Unit	Total Cost
DCV	1	\$1,663.90	3	\$96.67	\$1,953.91
DCV and VFD with two speed modes (40% ventilating & 90% heating/cooling)	1	\$3,025.38	4	\$96.67	\$3,412.06
DCV and VFD with three speed modes (40% ventilating, 75% 1 <sup>st</sup> stage heating/cooling, & 90% 2 <sup>nd</sup> stage heating/cooling)	1	\$3,487.00	4	\$96.67	\$3,873.68

**LOADSHAPE**

Commercial ventilation C23

**COINCIDENCE FACTOR**

- CF<sub>SSP</sub> = Summer System Peak Coincidence Factor for Commercial cooling (during system peak hour)  
= 91.3% <sup>936</sup>
- CF<sub>PJM</sub> = PJM Summer Peak Coincidence Factor for Commercial cooling (average during peak period)  
= 47.8% <sup>937</sup>

---

**Algorithm**

---

**CALCULATION OF ENERGY SAVINGS**

To determine the savings associated with the Advanced Rooftop Controls (ARC) measure we utilized the available IL TRM prototype eQuest models which were initially created by the Energy Center of Wisconsin<sup>938</sup> but modified by VEIC in 2014 as part of the IL TRM v4.0 Equivalent Full Load Hours (EFLH) update. For each building type we used the most recent versions of the models for our baseline models (Assembly was not part of EFLH update). These models which were used are the most up-to-date versions and are readily available on the [VEIC SharePoint site](#), under the [TRM Reference Documents Section](#).

Upon examination of the ComEd building prototype models we found several of the baseline models did not have packaged single zone (PSZ) units. This measure is targeting packaged single zone HVAC systems. Therefore, as a basis for savings calculations, we chose only models that: 1) utilized PSZ HVAC systems, and 2) aligned with the small commercial building type applicable to this measure. Once the ComEd baseline models were selected, we determined several modifications were necessary to the prototype models in order to represent the baseline scenario for this measure:

1. Multistage PSZ HVAC System with Constant Volume Supply Fan
2. Optimized Economizer Controls by Climate Zone
  - a. Economizer Changeover Type – Set to fixed Dry Bulb

<sup>936</sup> Based on analysis of Itron eShape data for Missouri, calibrated to Illinois loads, supplied by Ameren. The AC load during the utility’s peak hour is divided by the maximum AC load during the year.

<sup>937</sup>Based on analysis of Itron eShape data for Missouri, calibrated to Illinois loads, supplied by Ameren. The average AC load over the PJM peak period (1-5pm, M-F, June through August) is divided by the maximum AC load during the year.

<sup>938</sup> Energy Center of Wisconsin, ComEd Portfolio Modeling Report, July 30, 2010.

- b. Economizer High-Limit Control Setpoints – Setpoints based on ASHRAE Climate Zones Fixed Dry Bulb Temperature recommendations.
- c. Enable Integrated Operation – Allows economizer to operate simultaneously with mechanical cooling

Additionally, several the building prototype models were found to have supply fan total static pressure modeled inputs that seem excessive and atypical for packaged single zone rooftop units – these included convenience stores (5 in. wc), manufacturing facilities (5 in. wc), office low rises (5 in. wc), religious buildings (5 in. wc), and restaurants (5 in. wc). The remaining models had supply fan total static pressure inputs more in line with what we would expect to find for packaged single zone rooftop units, ranging from 1.3 to 2 in. wc. For each model having a supply fan total static pressure above 2 in. wc, model inputs were adjusted to set these to 2 in. wc. To implement the modifications shown above, changes were made to eQUEST keywords in the ComEd prototype models as shown in the following table. Hard-coded system capacities and supply airflows can be found in the attached “Advanced Rooftop Controls\_End Use Analysis\_IL TRM.xlsx” spreadsheet.

**Table 2 – Prototype Modifications to eQuest Keywords**

Component Adjusted	eQuest Keyword	IL TR Value	Modified Prototype Value
System - System Type	SYSTEM:TYPE	PSZ	PVVT
System - Airflow and Temperature Control	SYSTEM:AIR/TEMP-CONTROL	N/A	STAGED-VOLUME
System – Supply Fan Total Static Pressure	SYSTEM:SUPPLY-STATIC	Varies	If >2: 2 Else: IL TR Value
System - Cooling and Heating Capacities	SYSTEM:COOLING-CAPACITY SYSTEM:HEATING-CAPACITY	Auto-sized	Hard-coded (after retrieving auto-sized outputs)
System - Supply Fan Control	SYSTEM:FAN-CONTROL	Varies	CONSTANT-VOLUME
System - Supply Fan Ratios	SYSTEM:MIN-FLOW-RATIO SYSTEM:CMIN-FLOW-RATIO SYSTEM:HMIN-FLOW-RATIO SYSTEM:-MAX-FAN-RATIO	N/A	1
System - Supply Airflow	SYSTEM:SUPPLY-FLOW	Auto-sized	Hard-coded (after retrieving auto-sized outputs)
Economizer - Changeover Type	SYSTEM:OA-CONTROL	Fixed	Single Dry-Bulb
Economizer - Changeover Setpoint	SYSTEM-ECONO-LIMIT-T	Varies	ASHRAE 90.1-2013 – High-Limit Shutoff Control Settings: ASHRAE CLIMATE ZONE – 4A = 65°F ASHRAE CLIMATE ZONE – 5A = 70°F
Economizer - Integrated Operation	SYSTEM:ECONO-LOCKOUT	Yes	No

Further modifications were then made to these baseline models to simulate the following measure scenarios:

1. Demand-controlled ventilation (DCV) controls
2. DCV and supply fan variable frequency drive (VFD) with two fan speed modes
  - a. 40% fan speed for ventilating
  - b. 90% fan speed for heating and cooling
3. DCV and supply fan VFD with three fan speed modes

- a. 40% fan speed for ventilating
- b. 75% fan speed for 1<sup>st</sup> stage heating and cooling
- c. 90% fan speed for 2<sup>nd</sup> and higher stage heating and cooling

The eQuest modifications from the baseline models to represent these measure scenarios are shown in the following table. Full modeled energy end use and savings summaries can be found in the attached “Advanced Rooftop Controls\_End Use Analysis\_IL TRM.xlsx” spreadsheet.

**Table 3 – Baseline and Measure Scenario eQuest Keywords**

Component Adjusted	eQuest Keyword	Baseline Value	Measure Scenario Values		
			1	2	3
System - Minimum Outside Air Control	SYSTEM:MIN-OA-METHOD	Fraction of Design Flow	DCV Return Sensor	DCV Return Sensor	DCV Return Sensor
System - Supply Airflow	SYSTEM:SUPPLY-FLOW	Hard-coded	1.0 × Hard-coded value	0.9 × Hard-coded value	0.9 × Hard-coded value
System - Supply Fan Control	SYSTEM:FAN-CONTROL	CONSTANT-VOLUME	CONSTANT-VOLUME	FAN-EIR-FPLR	FAN-EIR-FPLR
System - Supply Fan Ratios	SYSTEM:MIN-FLOW-RATIO	1	1	0.44*	0.44*
	SYSTEM:CMIN-FLOW-RATIO	1	1	1	0.83**
	SYSTEM:HMIN-FLOW-RATIO	1	1	1	0.83**
	SYSTEM:-MAX-FAN-RATIO	1	1	1	1

\*Since the total supply flow is limited by 0.9 of the baseline, a value of 0.44 for the minimum flow ratio results in a 40% fan speed:  $0.4/0.9=0.44$

\*\* Since the total supply flow is limited by 0.9 of the baseline, a value of 0.83 for the minimum heating/cooling flow ratios results in a 75% fan speed:  $0.75/0.9=0.83$

With these modifications in place each scenario was simulated in eQuest for each chosen IL TRM prototype building type across the five TRM climate zones. Whole building electric and gas savings were determined from the simulation output and are presented in the following sections. Electric savings have been normalized by cooling tons and heating savings by furnace kBtuh output.

**ELECTRIC ENERGY SAVINGS**

$$\Delta kWh = (\text{Capacity}_{\text{Cool}} \times \text{Normalized Electric Cooling Energy Savings}) + (\text{Capacity}_{\text{Heat}} \times \text{Normalized Electric Heating Energy Savings})$$

Where:

Capacity<sub>Cool</sub> = capacity of the cooling equipment in tons (nominal tonnage may be used).  
 = Actual

Normalized Electric Cooling Energy Savings  
 = kWh/ton savings value for the appropriate combination of building type, climate zone, and measure scenario per Table 4 – Electric Cooling Energy Savings Summary (kWh/ton)

**Table 4 – Electric Cooling Energy Savings Summary (kWh/ton)**

Building Type - IL TRM Prototype Model Name	Rockford - Zone 1			Chicago - Zone 2			Springfield - Zone 3			Mt Vernon/Belleville - Zone 4			Marion - Zone 5		
	Measure Scenario:														
	1 - DCV 2 - DCV and VFD w/ 2-speed fan control 3 - DCV and VFD w/ 3-speed fan control														
	1	2	3	1	2	3	1	2	3	1	2	3	1	2	3
Assembly	52.0	145.8	168.7	51.4	154.6	175.5	85.2	189.0	205.8	95.7	199.7	213.7	89.7	200.8	210.4
Assisted Living	8.0	574.4	604.7	8.8	580.5	605.5	14.7	578.2	598.7	15.6	589.1	609.4	16.5	600.9	615.5
College	49.7	410.8	448.4	54.1	410.4	442.0	106.5	464.1	490.9	139.1	514.3	537.0	158.7	511.9	526.3
Conditioned Storage	1.9	339.8	393.6	3.5	355.1	404.5	5.9	346.3	388.6	9.5	349.5	384.5	10.3	349.5	371.7
Convenience Store	46.4	918.9	984.1	49.9	921.0	977.0	82.3	955.1	1,000.2	86.9	996.3	1,035.0	103.7	998.3	1,022.7
Garage	14.8	479.7	578.9	19.2	482.9	573.6	25.9	510.4	586.3	48.4	570.1	640.3	53.0	589.0	648.7
Grocery	41.8	480.1	505.1	43.9	486.5	507.6	68.1	502.8	520.4	83.2	536.1	550.6	89.7	539.8	547.9
Manufacturing Facility	7.7	773.4	824.8	9.0	761.4	807.1	19.6	771.8	809.3	30.8	801.2	832.8	34.2	784.9	802.5
Office Low Rise	15.2	1,071.2	1,147.3	17.2	1,065.8	1,131.8	23.1	1,062.2	1,115.7	30.5	1,091.4	1,137.7	31.2	1,042.2	1,071.7
Religious Building	6.5	869.4	1,016.9	6.3	894.6	1,029.6	11.1	931.0	1,047.1	15.5	1,005.4	1,108.3	15.0	1,051.1	1,134.0
Restaurant	13.8	554.0	598.2	14.9	574.2	610.8	26.4	564.5	596.6	27.7	606.3	637.2	25.8	603.5	628.3
Retail Department Store	34.0	692.6	751.0	34.4	697.7	749.0	55.4	715.0	757.7	60.8	725.4	761.1	64.3	723.2	743.8
Retail Strip Mall	30.9	739.7	782.5	32.9	734.1	770.5	50.8	748.5	776.8	55.3	761.3	784.8	60.1	755.2	768.4

Capacity<sub>Heat</sub> = capacity of the heating equipment in tons (nominal tonnage may be used).  
= Actual

Normalized Electric Heating Energy Savings

= kWh/ton savings value for the appropriate combination of building type, climate zone, and measure scenario per Table 5 – Electric Energy Heating Savings Summary (kWh/ton)<sup>939</sup>

<sup>939</sup> Values for electric heat are based on converting the gas therm/kBtu/h factors to electric kWh/ton factors factoring in the gas heating efficiencies used in the models and assuming a 2.3 COP heat pump. See 'ARC\_ElectricHeatCalculation.xls' for calculation.

**Table 5 – Electric Heating Energy Savings Summary (kWh/ton)**

	Rockford - Zone 1			Chicago - Zone 2			Springfield - Zone 3			Mt Vernon/Belleville - Zone 4			Marion - Zone 5		
	Measure Scenario: 1 - DCV 2 - DCV and VFD w/ 2-speed fan control 3 - DCV and VFD w/ 3-speed fan control														
Building Type	1	2	3	1	2	3	1	2	3	1	2	3	1	2	3
Assembly	868.6	893.1	893.1	868.6	893.1	893.1	746.3	795.2	783.0	734.0	783.0	770.7	734.0	807.4	795.2
Assisted Living	119.3	59.6	23.9	95.4	47.7	11.9	83.5	35.8	11.9	83.5	59.6	23.9	71.6	59.6	23.9
College	880.8	831.9	807.4	770.7	734.0	709.6	648.4	611.7	599.5	526.1	513.8	489.3	342.5	330.3	318.1
Conditioned Storage	305.8	171.3	146.8	269.1	134.6	110.1	244.7	110.1	85.6	232.4	97.9	73.4	183.5	48.9	36.7
Convenience Store	587.2	464.9	440.4	526.1	403.7	379.2	452.6	342.5	330.3	428.2	330.3	305.8	354.8	269.1	244.7
Garage	59.6	47.7	35.8	47.7	35.8	35.8	47.7	35.8	23.9	47.7	35.8	23.9	47.7	35.8	35.8
Grocery	894.6	835.0	811.1	799.2	739.5	727.6	703.7	656.0	632.2	632.2	596.4	584.5	489.0	453.3	441.3
Manufacturing Facility	59.6	47.7	35.8	47.7	35.8	35.8	47.7	35.8	23.9	35.8	23.9	23.9	23.9	23.9	23.9
Office - Low Rise	334.0	143.1	119.3	298.2	107.4	83.5	238.6	95.4	71.6	214.7	71.6	59.6	155.1	23.9	23.9
Religious Building	107.4	131.2	155.1	95.4	107.4	131.2	83.5	95.4	107.4	71.6	95.4	107.4	71.6	71.6	83.5
Restaurant	345.9	262.4	226.6	298.2	214.7	190.8	262.4	190.8	167.0	238.6	190.8	155.1	202.8	155.1	131.2
Retail - Department Store	298.2	178.9	167.0	274.3	155.1	131.2	238.6	131.2	119.3	214.7	131.2	107.4	178.9	107.4	95.4
Retail - Strip Mall	286.3	226.6	202.8	250.5	190.8	178.9	214.7	167.0	155.1	202.8	167.0	155.1	178.9	143.1	131.2

**For example**, a 10-ton rooftop heat pump on an office low rise building in Chicago installs DCV with 2-speed supply fan control (operating at 40% in ventilating mode and 90% in heating and cooling modes):

$$\begin{aligned}
 \Delta kWh &= (\text{Capacity}_{\text{Cool}} \times \text{Normalized Electric Cooling Energy Savings}) + (\text{Capacity}_{\text{Heat}} \times \text{Normalized Electric Heating Energy Savings}) \\
 &= (10 \text{ tons} \times 1,065.8 \text{ kWh/ton}) + (10 \text{ tons} \times 107.4 \text{ kWh/ton}) \\
 &= 11,732 \text{ kWh}
 \end{aligned}$$



**SUMMER COINCIDENT PEAK DEMAND SAVINGS**

$$\Delta kW_{SSP} = (\text{tons}) \times \text{Normalized Electric Cooling Peak Demand Savings} \times CF_{SSP}$$

$$\Delta kW_{PJM} = (\text{tons}) \times \text{Normalized Electric Cooling Peak Demand Savings} \times CF_{PJM}$$

Where:

tons = capacity of the cooling equipment in tons (nominal tonnage may be used).  
 = Actual

CF<sub>SSP</sub> = Summer System Peak Coincidence Factor for Commercial cooling (during system peak hour)  
 = 91.3%<sup>940</sup>

CF<sub>PJM</sub> = PJM Summer Peak Coincidence Factor for Commercial cooling (average during peak period)  
 = 47.8%<sup>941</sup>

Normalized Electric Peak Demand Savings

= kW/ton savings value for the appropriate combination of building type, climate zone, and measure scenario per Table 6 – Electric Peak Demand Savings Summary (kW/ton)

**Table 6 – Electric Peak Demand Savings Summary (kW/ton)**

Building Type - IL TRM Prototype Model Name	Rockford - Zone 1			Chicago - Zone 2			Springfield - Zone 3			Mt Vernon/Belleville - Zone 4			Marion - Zone 5		
	Measure Scenario:														
	1 - DCV 2 - DCV and VFD w/ 2-speed fan control 3 - DCV and VFD w/ 3-speed fan control														
	1	2	3	1	2	3	1	2	3	1	2	3	1	2	3
Assembly	0.024	0.107	0.107	0.086	0.126	0.126	0.015	0.042	0.042	0.069	0.095	0.095	0.048	0.064	0.064
Assisted Living	0.021	0.116	0.116	0.021	0.075	0.075	0.018	0.086	0.086	0.021	0.092	0.092	0.024	0.081	0.081
College	0.007	0.207	0.207	0.007	0.090	0.090	0.006	0.179	0.179	0.005	0.132	0.132	0.009	0.074	0.074
Conditioned Storage	0.007	0.065	0.065	0.006	0.083	0.083	0.010	0.096	0.096	0.005	0.060	0.060	0.007	0.071	0.071
Convenience Store	0.047	0.369	0.369	0.053	0.394	0.394	0.042	0.395	0.395	0.017	0.356	0.356	0.067	0.390	0.390
Garage	0.012	0.054	0.054	0.011	0.053	0.053	0.011	0.053	0.053	0.011	0.068	0.068	0.007	0.061	0.061
Grocery	0.065	0.122	0.122	0.034	0.080	0.080	0.033	0.088	0.088	0.072	0.119	0.119	0.033	0.082	0.082
Manufacturing Facility	0.008	0.335	0.335	0.006	0.296	0.296	-0.003	0.283	0.283	0.000	0.333	0.333	0.049	0.376	0.376
Office Low Rise	0.011	0.395	0.395	0.009	0.346	0.346	0.007	0.366	0.366	0.011	0.384	0.384	0.029	0.385	0.385
Religious Building	0.000	0.462	0.465	0.000	0.406	0.409	0.000	0.461	0.461	0.000	0.456	0.457	0.000	0.464	0.467
Restaurant	0.030	0.231	0.231	0.034	0.162	0.162	0.023	0.113	0.113	0.033	0.134	0.134	0.006	0.069	0.069
Retail Department Store	0.057	0.152	0.152	0.042	0.120	0.120	0.029	0.099	0.099	0.029	0.113	0.113	0.066	0.149	0.149
Retail Strip Mall	0.046	0.171	0.171	0.046	0.191	0.191	0.042	0.189	0.189	0.020	0.158	0.158	0.066	0.178	0.178

<sup>940</sup> Based on analysis of Itron eShape data for Missouri, calibrated to Illinois loads, supplied by Ameren. The AC load during the utility’s peak hour is divided by the maximum AC load during the year.

<sup>941</sup> Based on analysis of Itron eShape data for Missouri, calibrated to Illinois loads, supplied by Ameren. The average AC load over the PJM peak period (1-5pm, M-F, June through August) is divided by the maximum AC load during the year.

**For example**, a 10-ton rooftop air conditioner on an office low rise building in Chicago installs DCV with 2-speed supply fan control (operating at 40% in ventilating mode and 90% in heating and cooling modes) using the Summer System Peak Coincidence Factor:

$$\begin{aligned} \Delta kW &= (10 \text{ tons}) \times (0.346 \text{ kW/ton}) \times 91.3\% \\ &= 3.159 \text{ kW} \end{aligned}$$

**FOSSIL FUEL SAVINGS**

$$\Delta \text{Therms} = (\text{kBtuh output}) \times \text{Normalized Gas Energy Savings}$$

Where:

kBtuh = heating output of the gas furnace in kBtuh  
 = Actual

Normalized Gas Energy Savings

= therms/kBtuh output savings value for the appropriate combination of building type, climate zone, and measure scenario per Table 7 – Gas Energy Savings Summary (therms/kBtuh output)

**Table 7 – Gas Energy Savings Summary (therms/kBtuh output)**

Building Type - IL TRM Prototype Model Name	Rockford - Zone 1			Chicago - Zone 2			Springfield - Zone 3			Mt Vernon/Belleville - Zone 4			Marion - Zone 5				
	Measure Scenario:																
	1 - DCV			2 - DCV and VFD w/ 2-speed fan control			3 - DCV and VFD w/ 3-speed fan control			1 - DCV			2 - DCV and VFD w/ 2-speed fan control			3 - DCV and VFD w/ 3-speed fan control	
	1	2	3	1	2	3	1	2	3	1	2	3	1	2	3		
Assembly	7.1	7.3	7.3	7.1	7.3	7.3	6.1	6.5	6.4	6.0	6.4	6.3	6.0	6.6	6.5		
Assisted Living	1.0	0.5	0.2	0.8	0.4	0.1	0.7	0.3	0.1	0.7	0.5	0.2	0.6	0.5	0.2		
College	7.2	6.8	6.6	6.3	6.0	5.8	5.3	5.0	4.9	4.3	4.2	4.0	2.8	2.7	2.6		
Conditioned Storage	2.5	1.4	1.2	2.2	1.1	0.9	2.0	0.9	0.7	1.9	0.8	0.6	1.5	0.4	0.3		
Convenience Store	4.8	3.8	3.6	4.3	3.3	3.1	3.7	2.8	2.7	3.5	2.7	2.5	2.9	2.2	2.0		
Garage	0.5	0.4	0.3	0.4	0.3	0.3	0.4	0.3	0.2	0.4	0.3	0.2	0.4	0.3	0.3		
Grocery	7.5	7.0	6.8	6.7	6.2	6.1	5.9	5.5	5.3	5.3	5.0	4.9	4.1	3.8	3.7		
Manufacturing Facility	0.5	0.4	0.3	0.4	0.3	0.3	0.4	0.3	0.2	0.3	0.2	0.2	0.2	0.2	0.2		
Office Low Rise	2.8	1.2	1.0	2.5	0.9	0.7	2.0	0.8	0.6	1.8	0.6	0.5	1.3	0.2	0.2		
Religious Building	0.9	1.1	1.3	0.8	0.9	1.1	0.7	0.8	0.9	0.6	0.8	0.9	0.6	0.6	0.7		
Restaurant	2.9	2.2	1.9	2.5	1.8	1.6	2.2	1.6	1.4	2.0	1.6	1.3	1.7	1.3	1.1		
Retail Department Store	2.5	1.5	1.4	2.3	1.3	1.1	2.0	1.1	1.0	1.8	1.1	0.9	1.5	0.9	0.8		
Retail Strip Mall	2.4	1.9	1.7	2.1	1.6	1.5	1.8	1.4	1.3	1.7	1.4	1.3	1.5	1.2	1.1		

**For example**, a rooftop unit with a 148 kBtuh output gas furnace on an office low-rise building in Chicago installs DCV with 2-speed supply fan control (operating at 40% in ventilating mode and 90% in heating and cooling modes):

$$\begin{aligned} \Delta \text{Therms} &= (148 \text{ kBtuh}) \times (0.9 \text{ therms/kBtuh output}) \\ &= 133.2 \text{ therms} \end{aligned}$$

**WATER AND OTHER NON-ENERGY IMPACT DESCRIPTIONS AND CALCULATION**

N/A

**DEEMED O&M COST ADJUSTMENT CALCULATION**

N/A

**MEASURE CODE: CI-HVC-ARTC-V03-230101**

**REVIEW DEADLINE: 1/1/2027**

4.4.42 Advanced Thermostats for Small Commercial – Retired 12/31/2019. Replaced with  
4.4.48 Small Commercial Thermostats

#### 4.4.43 Packaged RTU Sealing

##### **DESCRIPTION**

The HVAC Packaged RTU Sealing Measure targets areas of the RTU that are readily accessible and can be easily sealed. By sealing the following areas, the amount of uncontrolled infiltration will be reduced leading to increased occupant comfort and an overall reduction in energy use.

The measure seeks to target the following three areas for sealing.

1. Economizer Hood – Seal the interior and exterior seams that connect the economizer to the RTU using UL listed metal tape and/or silicone caulking.
2. RTU Curb – Seal supply and return duct seams inside of RTU with mastic along with any leaks that are found around the perimeter of the roof to RTU connection using UL listed metal tape and/or silicone caulking.
3. Non-Removable Cabinet Panels – Seal all cabinet seams that are not typically removed during basic service (i.e., control panel) using UL listed metal tape and/or silicone caulking.

Uncontrolled infiltration of non-conditioned outside air (OSA) is a known issue for packaged rooftop units (RTU). This leakage can occur thru the curb, economizer assembly connection and cabinet panels. This leakage not only influences occupant comfort but also increases energy usage by increasing the heating and cooling loads while also reducing the unit's operating energy efficiency.

Prior to a recently released laboratory and field study developed by Robert Mowris & Associates, Inc.,<sup>942</sup> the energy effects of uncontrolled infiltration through cabinet leakage were difficult to quantify. However, this study determined that uncontrolled OSA infiltration not only increases the amount of energy to condition the excess air but also reduces the unit's operating efficiency (sensible EER) by 5.4%. By reducing the amount of uncontrolled OSA infiltration through RTU sealing the unit's operating efficiency (EER) can be increased reducing the amount of cooling energy. (Note: The referenced study quantifies improvements only from sealing the economizer hood – sealing the curb and non-access panels are recommended practice here but savings have not been quantified for these actions and may be in a future revision.)

This measure is only appropriate for packaged single zone rooftop units. Custom calculations are required for savings for built up air handling units or packaged multizone systems.

##### **DEFINITION OF EFFICIENT EQUIPMENT**

The efficient equipment condition is assumed to be a packaged HVAC system that has had the economizer hood, curb and non-access cabinet panels sealed.

##### **DEFINITION OF BASELINE EQUIPMENT**

The baseline equipment condition is assumed to be an operational packaged HVAC system that has not been previously sealed. The packaged HVAC systems must be single zone and must have a functioning economizer.

##### **DEEMED LIFETIME OF EFFICIENT EQUIPMENT**

Because the measure targets existing packaged RTU units, the deemed lifetime of the measure is assumed to be 5 years.<sup>943</sup>

---

<sup>942</sup>Robert Mowris & Associates, Inc., "Laboratory Test Results of Commercial Packaged HVAC Maintenance Faults," California Public Utilities Commission, Feb 15, 2016 page 203.

<sup>943</sup> Assumed to be one third of effective useful life of an RTU (15 years).

**DEEMED MEASURE COST**

Actual measure costs should be used if available. If costs are not available, the deemed measure cost below listed below can be used. The deemed measure costs are detailed for each individual RTU.

Measure	Material Unit	Material Cost / Unit	Labor Unit (Hours)	Labor Rate / Unit	Total Cost
HVAC Packaged RTU Sealing	1	\$48.99	1.5	\$97	\$194.49

**LOADSHAPE**

Loadshape C03 - Commercial Cooling

**COINCIDENCE FACTOR**

- CF<sub>SSP</sub> = Summer System Peak Coincidence Factor for Commercial cooling (during system peak hour)  
= 91.3%<sup>944</sup>
- CF<sub>PJM</sub> = PJM Summer Peak Coincidence Factor for Commercial cooling (average during peak period)  
= 47.8%<sup>945</sup>

---

**Algorithm**

---

**CALCULATION OF ENERGY SAVINGS**

To determine the savings associated with the Packaged RTU Sealing measure available IL TRM prototype eQuest models, which were initially created by the Energy Center of Wisconsin<sup>946</sup> but modified by VEIC in 2014 as part of the IL TRM v4.0 Equivalent Full Load Hours (EFLH) update, were utilized. For each building type we used the most recent versions of the models for our baseline models (Assembly was not part of EFLH update).

This measure is targeting packaged single zone HVAC systems. Therefore, as a basis for savings calculations, only models that had the following characteristics were chosen: 1) Packaged-Single Zone (PSZ) HVAC systems; and 2) aligned with the small commercial building type applicable to this measure. Several modifications to the models were necessary in order to simulate a functioning airside economizer, which is assumed to be present in the baseline scenario for this measure:

- 3) Optimized Economizer Controls by Climate Zone
  - a. Economizer Changeover Type – Set to fixed Dry Bulb
  - b. Economizer High-Limit Control Setpoints – Setpoints based on ASHRAE Climate Zones Fixed Dry Bulb Temperature recommendations.
  - c. Enable Integrated Operation – Allows economizer to operate simultaneously with mechanical cooling

To determine the energy use associated with an unsealed RTU, the prototype models were modified using the associated reduction in efficiency reported in a Robert Mowris and Associates, Inc. study that was performed for the California Public Utilities Commission in 2016.<sup>947</sup> For further detail on the full modeled energy end use and savings summaries, see: “Packaged RTU Sealing\_End Use Analysis\_IL TRM 09042018.xlsx” spreadsheet.

<sup>944</sup> Based on analysis of Itron eShape data for Missouri, calibrated to Illinois loads, supplied by Ameren. The AC load during the utility’s peak hour is divided by the maximum AC load during the year.

<sup>945</sup> Based on analysis of Itron eShape data for Missouri, calibrated to Illinois loads, supplied by Ameren. The average AC load over the PJM peak period (1-5pm, M-F, June through August) is divided by the maximum AC load during the year.

<sup>946</sup> Energy Center of Wisconsin, ComEd Portfolio Modeling Report, July 30, 2010.

<sup>947</sup> Robert Mowris & Associates, Inc., “Laboratory Test Results of Commercial Packaged HVAC Maintenance Faults,” California Public Utilities Commission, Feb 15, 2016 Section 5.4.

After analyzing the modeled cooling annual energy usage for both the baseline (unsealed) and measure (sealed) model scenarios it was determined that the building type and climate zone variables had a minimal impact on the overall energy savings associated with the measure. As a result, the overall average savings factor of 4.67% was deemed applicable for any small commercial building type across all climate zones. This single savings value used in conjunction with the energy and demand savings calculations listed in the following sections will allow the savings to be calculated based on the unit size and equivalent full load hours listed in the Illinois Technical Resource Manual (TRM).

**ELECTRIC ENERGY SAVINGS**

$$\Delta kWh = (kBtu/hr) / EER_{before} * EFLH_{cooling} * \%Savings$$

Where:

- kBtu/hr = rated capacity of the cooling equipment actually installed in kBtu per hour (1 ton of cooling capacity equals 12 kBtu/hr).  
= Actual
- EER<sub>before</sub> = Energy Efficiency Ratio (EER) of the baseline equipment  
= Actual
- %Savings = Deemed savings percentage  
= 4.67%<sup>948</sup>
- EFLH<sub>cooling</sub> = Equivalent Full Load Hours for cooling in Existing Buildings from section 4.4 HVAC End Use

**For example**, a 12 EER 5-ton rooftop air conditioner on a department store in Rockford receives packaged RTU sealing:

$$\begin{aligned} \Delta kWh &= (5 * 12) / 12 * 639 * 4.67\% \\ &= 149.2 kWh \end{aligned}$$

**SUMMER COINCIDENT PEAK DEMAND SAVINGS**

$$\Delta kW_{ssp} = (kBtu/hr) / EER_{before} * \%Savings * CF_{SSP}$$

$$\Delta kW_{pjm} = (kBtu/hr) / EER_{before} * \%Savings * CF_{PJM}$$

Where:

- kBtu/hr = Capacity of the cooling equipment actually installed in kBtu per hour (1 ton of cooling capacity equals 12 kBtu/hr).  
= Actual
- EER<sub>before</sub> = Energy Efficiency Ratio (EER) of the baseline equipment  
= Actual
- %Savings = Deemed savings percentage  
= 4.67%

<sup>948</sup> The average cooling energy savings for all building types and climate zones, as determined by modeling 13 small commercial building types across 5 weather zones utilizing the prototype TRM eQuest models. For additional reference on the methodology and approach to the calculation of the deemed savings factor, see “Packaged RTU Sealing\_End Use Analysis\_IL TRM 2022.xlsx”.

CF<sub>SSP</sub> = Summer System Peak Coincidence Factor for Commercial cooling (during system peak hour)

$$= 91.3\% \text{ }^{949}$$

CF<sub>PJM</sub> = PJM Summer Peak Coincidence Factor for Commercial cooling (average during peak period)

$$= 47.8\% \text{ }^{950}$$

**For example,** a 12 EER 5-ton rooftop air conditioner using the Summer System Peak Coincidence Factor receives RTU sealing:

$$\begin{aligned} \Delta kW &= (5 \cdot 12) / 12 * 4.67\% * 91.3\% \\ &= 0.213 \text{ kW} \end{aligned}$$

### FOSSIL FUEL SAVINGS

$$\Delta \text{Therm} = (\text{kBtu/hr}) / 100 / \text{Efficiency}_{\text{before}} * \text{EFLH}_{\text{heating}} * \% \text{Savings}$$

Where:

kBtu/hr = rated capacity of the heating equipment actually installed in kBtu per hour  
= Actual

100 = Converts kBtu/hr to Therms/hr

Efficiency<sub>before</sub> = Efficiency of the baseline equipment (rated)  
= Actual

%Savings = Deemed savings percentages by building type and climate zone are provided in the following table

Building Type	Savings Percentage				
	Zone 1 (Rockford)	Zone 2 (Chicago)	Zone 3 (Springfield)	Zone 4 (Belleville)	Zone 5 (Marion)
Assembly	2.84%	2.86%	2.86%	2.98%	2.94%
Assisted Living	4.01%	4.15%	4.35%	4.64%	5.44%
College	3.86%	3.88%	3.97%	4.09%	5.10%
Conditioned Storage (Warehouse)	0.92%	0.90%	0.87%	1.00%	1.23%
Convenience Store	3.07%	3.20%	3.43%	3.70%	4.63%
Garage	0.20%	0.21%	0.22%	0.23%	0.29%
Grocery	3.38%	3.49%	3.60%	3.79%	4.57%
Manufacturing Facility	0.18%	0.16%	0.16%	0.16%	0.16%
Office - Low Rise	2.19%	2.23%	2.37%	2.46%	2.96%
Religious Building	0.28%	0.28%	0.30%	0.31%	0.37%
Restaurant	2.76%	2.83%	2.96%	3.11%	3.58%
Retail - Department Store	1.87%	1.91%	2.00%	2.14%	2.88%
Retail - Strip Mall	2.06%	2.12%	2.29%	2.46%	3.17%

<sup>949</sup> Based on analysis of Itron eShape data for Missouri, calibrated to Illinois loads, supplied by Ameren. The AC load during the utility's peak hour is divided by the maximum AC load during the year.

<sup>950</sup> Based on analysis of Itron eShape data for Missouri, calibrated to Illinois loads, supplied by Ameren. The average AC load over the PJM peak period (1-5pm, M-F, June through August) is divided by the maximum AC load during the year.



$EFLH_{\text{heating}}$  = Equivalent Full Load Hours for heating in Existing Buildings from section 4.4 HVAC End Use

**For example**, a packaged RTU with an 80% efficient 150-kBtu/hr gas furnace on a department store in Rockford receives packaged RTU sealing:

$$\begin{aligned}\Delta\text{Therm} &= (150 / 100) / 80\% * 1,365 * 1.87\% \\ &= 47.9 \text{ Therms}\end{aligned}$$

**WATER AND OTHER NON-ENERGY IMPACT DESCRIPTIONS AND CALCULATION**

N/A

**DEEMED O&M COST ADJUSTMENT CALCULATION**

N/A

**MEASURE CODE: CI-HVC-PRTU-V02-230101**

**REVIEW DEADLINE: 1/1/2026**

## 4.4.44 Commercial Ground Source and Ground Water Source Heat Pump

### DESCRIPTION

This measure characterizes the installation of a Ground Source Heat Pump under the following scenarios:

- A. New Construction:
  - i. The installation of a new Ground Source Heat Pump system meeting ENERGY STAR efficiency standards presented below in a new C&I building.
  - ii. Note the baseline in this case should be determined via EM&V and the algorithms are provided to allow savings to be calculated from any baseline condition.
- B. Time of Sale:
  - i. The planned installation of a new Ground Source Heat Pump system meeting ENERGY STAR efficiency standards presented below to replace an existing system(s) that does not meet the criteria for early replacement described in section C below.
  - ii. Note the baseline in this case is an equivalent replacement system to that which exists currently in the building. Where unknown, the baseline should be determined via EM&V and the algorithms are provided to allow savings to be calculated from any baseline condition. The calculation of savings is dependent on whether an incentive for the installation has been provided by both a gas and electric utility, only an electric utility or only a gas utility.
  - iii. DHW savings are calculated based upon the fuel type and efficiency of the existing unit.
- C. Early Replacement/Retrofit:
  - i. The early removal of functioning electric or gas space heating and/or cooling systems from service, prior to the natural end of life, and replacement with a new high efficiency Ground Source Heat Pump system.
  - ii. Note the baseline in this case is the existing equipment being replaced. The calculation of savings is dependent on whether an incentive for the installation has been provided by both a gas and electric utility, only an electric utility or only a gas utility. DHW savings are calculated based upon the fuel and efficiency of the existing unit.
  - iii. Early Replacement determination will be based on meeting the following conditions:
    - The existing unit is operational when replaced, or
    - The existing unit requires minor repairs to be operational, defined as costing less than:<sup>951</sup>

Existing System	Maximum repair cost
Air Source Heat Pump	\$263/ton
Chiller	\$308/ton
Boiler (Steam)	\$3.87/kBtu
Boiler (Hot Water)	\$4.25/kBtu
Furnace	\$2.49/kBtu
Ground Source Heat Pump	\$2,185/ton

- All other conditions will be considered Time of Sale.

The Baseline efficiency of the existing unit replaced:

- Use actual existing efficiency whenever possible.
- If the efficiency of the existing unit is unknown, use assumptions based on the federal minimum standards provided in tables below.
- If the operational status or repair cost of the existing unit is unknown use time of sale assumptions.

<sup>951</sup> The Technical Advisory Committee agreed that if the cost of repair is less than 20% of the new baseline replacement cost (defined in the Measure Costs section), it can be considered early replacement.

The installation of the GSHP should meet the following design parameters to ensure a properly sized circulation pump. If the GSHP design does not meet the following parameters, a custom calculation should be performed to account for the motor energy consumed by the circulation pump. Optimal design parameters are:

- Circulation pump is included in the manufacturer assembly of the GSHP system  
Or;
- Circulation pump flow rate less than or equal to 3.0 GPM per system ton
- Variable flow controls on pumps serving systems greater than 10 tons. Variable flow controls include one of the following:
  - A variable speed system pump controlled from differential pressure and 2-way water flow control valves on each heat pump.
  - Individual on/off pumps on each heat pump controlled by heat pump demand. The heat pumps may be decoupled from the ground heat exchanger using a separate variable speed pump controlled by differential temperature across the ground loop.
- On/off or variable flow controls on pumps for systems less than 10 tons. On/off pump controls shall operate only when heat pump(s) are running.
- System pumping head less than 80 feet. For systems 10 tons or smaller system pumping head should not exceed 40 feet.

This measure was developed to be applicable to the following program types: TOS, NC, EREP. If applied to other program types, the measure savings should be verified.

#### **DEFINITION OF EFFICIENT EQUIPMENT**

For these products, the baseline equipment includes Air Conditioning, Space Heating and Domestic Hot Water Heating.

New Construction:

To calculate savings with an electric baseline, the baseline equipment is assumed to be an Air Source Heat Pump meeting the Federal Standard efficiency level as outlined in Table 2 (effective 1/1/2016 to 6/30/2019) or Table 7 (effective 7/1/2019 to 9/30/2022) or Table 12 (effective 10/1/2022) ; and a Federal Standard electric hot water heater efficiency level as outlined in Table 6 (effective 1/1/2016 to 6/30/2019) or Table 11 (effective 7/1/2019 to 9/30/2022) or Table 16 (effective 10/1/2022).

To calculate savings with a chiller/unitary cooling systems and boiler/furnace baseline, the baseline equipment is assumed to meet the minimum standard efficiencies as outlined in the Table 3 (effective 1/1/2016 to 6/30/2019) or Table 8 (effective 7/1/2019 to 9/30/2022) or Table 13 (effective 10/1/2022) for chillers/unitary cooling systems, and Table 4 (effective 1/1/2016 to 6/30/2019) or Table 9 (effective 7/1/2019 to 9/30/2022) or Table 14 (effective 10/1/2022) for boilers or Table 5 (effective 1/1/2016 to 6/30/2019) or Table 10 (effective 7/1/2019 to 9/30/2022) or Table 15 (effective 10/1/2022) for furnaces. If a desuperheater is installed, the domestic hot water heater minimum standard efficiency is calculated as per Table 6 (effective 1/1/2016 to 6/30/2019) or Table 11 (effective 7/1/2019 to 9/30/2022) or Table 16 (effective 10/1/2022) below.

In order for this characterization to apply, the baseline equipment is assumed to meet the efficiency requirements within the IECC code in effect on the date of the building permit. As code requirements and adoption can differ from municipality to municipality, the user should verify which version of code is applicable given these constraints.

Note, IECC 2021 is expected to become effective statewide in 2023. IECC 2018 is the requisite code for any projects with permitting dates spanning July 1, 2019 to the IECC 2021 effective date. Prior to July 1, 2019, IECC 2015 is the applicable code. If evaluation determines the applicable version of code, given location and timing, isn't an appropriate baseline due to supply constraints, low compliance, or other issues, the previous iteration of code may be used through 2023.

IECC 2021 leverages new DOE testing methods and associated metrics. The following conversion factors are recommended for use if the efficient equipment is not rated under the new testing procedure but the stipulated baseline is:<sup>952</sup>

$$\text{SEER2} = X * \text{SEER}$$

$$\text{EER2} = X * \text{EER}$$

$$\text{HSPF2} = X * \text{HSPF}$$

Where:

X	SEER2	EER2	HSPF2
Ducted	0.95	0.95	0.85
Ductless	1.00	1.00	0.90
Packaged	0.95	0.95	0.84

---

<sup>952</sup> Consortium for Energy Efficiency (CEE), Testing, Testing, M1, 2, 3, Transitioning to New Federal Minimum Standards, CEE Summer Program Meeting, June 10, 2022.

**Table 2: IECC 2015 ASHP Minimum Efficiency Requirements (effective 1/1/2016 to 6/30/2019):**

EQUIPMENT TYPE	SIZE CATEGORY	HEATING SECTION TYPE	SUBCATEGORY OR RATING CONDITION	MINIMUM EFFICIENCY		TEST PROCEDURE <sup>a</sup>
				Before 1/1/2016	As of 1/1/2016	
Air cooled (cooling mode)	< 65,000 Btu/h <sup>b</sup>	All	Split System	13.0 SEER <sup>c</sup>	14.0 SEER <sup>c</sup>	AHRI 210/240
			Single Package	13.0 SEER <sup>c</sup>	14.0 SEER <sup>c</sup>	
Through-the-wall, air cooled	≤ 30,000 Btu/h <sup>b</sup>	All	Split System	12.0 SEER	12.0 SEER	
			Single Package	12.0 SEER	12.0 SEER	
Single-duct high-velocity air cooled	< 65,000 Btu/h <sup>b</sup>	All	Split System	11.0 SEER	11.0 SEER	
Air cooled (cooling mode)	≥ 65,000 Btu/h and < 135,000 Btu/h	Electric Resistance (or None)	Split System and Single Package	11.0 EER	11.0 EER	
			All other	10.8 EER	10.8 EER	
	≥ 135,000 Btu/h and < 240,000 Btu/h	Electric Resistance (or None)	Split System and Single Package	10.6 EER	10.6 EER	
			All other	10.4 EER	10.4 EER	
	≥ 240,000 Btu/h	Electric Resistance (or None)	Split System and Single Package	9.5 EER	9.5 EER	
			All other	9.3 EER	9.3 EER	
Air cooled (heating mode)	< 65,000 Btu/h <sup>b</sup>	—	Split System	7.7 HSPF <sup>c</sup>	8.2 HSPF <sup>c</sup>	AHRI 210/240
			Single Package	7.7 HSPF <sup>c</sup>	8.0 HSPF <sup>c</sup>	
Through-the-wall, (air cooled, heating mode)	≤ 30,000 Btu/h <sup>b</sup> (cooling capacity)	—	Split System	7.4 HSPF	7.4 HSPF	
			Single Package	7.4 HSPF	7.4 HSPF	
Small-duct high velocity (air cooled, heating mode)	< 65,000 Btu/h <sup>b</sup>	—	Split System	6.8 HSPF	6.8 HSPF	
Air cooled (heating mode)	≥ 65,000 Btu/h and < 135,000 Btu/h (cooling capacity)	—	47°F db/43°F wb outdoor air	3.3 COP	3.3 COP	
			17°Fdb/15°F wb outdoor air	2.25 COP	2.25 COP	
	≥ 135,000 Btu/h (cooling capacity)	—	47°F db/43°F wb outdoor air	3.2 COP	3.2 COP	
			17°Fdb/15°F wb outdoor air	2.05 COP	2.05 COP	

**Table 3: IECC 2015 Electric Chillers, Air-Cooled and Water-Cooled minimum efficiencies (effective 1/1/2016 to 6/30/2019)**

EQUIPMENT TYPE	SIZE CATEGORY	UNITS	BEFORE 1/1/2015		AS OF 1/1/2015		TEST PROCEDURE <sup>c</sup>
			Path A	Path B	Path A	Path B	
Air-cooled chillers	< 150 Tons	EER (Btu/W)	≥ 9.562 FL	NA <sup>c</sup>	≥ 10.100 FL	≥ 9.700 FL	AHRI 550/590
			≥ 12.500 IPLV		≥ 13.700 IPLV	≥ 15.800 IPLV	
	≥ 150 Tons		≥ 9.562 FL	NA <sup>c</sup>	≥ 10.100 FL	≥ 9.700 FL	
			≥ 12.500 IPLV		≥ 14.000 IPLV	≥ 16.100 IPLV	
Air cooled without condenser, electrically operated	All capacities	EER (Btu/W)	Air-cooled chillers without condenser shall be rated with matching condensers and complying with air-cooled chiller efficiency requirements.				
Water cooled, electrically operated positive displacement	< 75 Tons	kW/ton	≤ 0.780 FL	≤ 0.800 FL	≤ 0.750 FL	≤ 0.780 FL	
			≤ 0.630 IPLV	≤ 0.600 IPLV	≤ 0.600 IPLV	≤ 0.500 IPLV	
	≥ 75 tons and < 150 tons		≤ 0.775 FL	≤ 0.790 FL	≤ 0.720 FL	≤ 0.750 FL	
			≤ 0.615 IPLV	≤ 0.586 IPLV	≤ 0.560 IPLV	≤ 0.490 IPLV	
	≥ 150 tons and < 300 tons		≥ 0.680 FL	≥ 0.718 FL	≥ 0.660 FL	≥ 0.680 FL	
			≥ 0.580 IPLV	≥ 0.540 IPLV	≥ 0.540 IPLV	≥ 0.440 IPLV	
	≥ 300 tons and < 600 tons		≤ 0.620 FL	≤ 0.639 FL	≤ 0.610 FL	≤ 0.625 FL	
			≤ 0.540 IPLV	≤ 0.490 IPLV	≤ 0.520 IPLV	≤ 0.410 IPLV	
≥ 600 tons	≤ 0.620 FL	≤ 0.639 FL	≤ 0.560 FL	≤ 0.585 FL			
		≤ 0.540 IPLV	≤ 0.490 IPLV	≤ 0.500 IPLV	≤ 0.380 IPLV		
Water cooled, electrically operated centrifugal	< 150 Tons	kW/ton	≤ 0.634 FL	≤ 0.639 FL	≤ 0.610 FL	≤ 0.695 FL	
			≤ 0.596 IPLV	≤ 0.450 IPLV	≤ 0.550 IPLV	≤ 0.440 IPLV	
	≥ 150 tons and < 300 tons		≤ 0.634 FL	≤ 0.639 FL	≤ 0.610 FL	≤ 0.635 FL	
			≤ 0.596 IPLV	≤ 0.450 IPLV	≤ 0.550 IPLV	≤ 0.400 IPLV	
	≥ 300 tons and < 400 tons		≤ 0.576 FL	≤ 0.600 FL	≤ 0.560 FL	≤ 0.595 FL	
			≤ 0.549 IPLV	≤ 0.400 IPLV	≤ 0.520 IPLV	≤ 0.390 IPLV	
	≥ 400 tons and < 600 tons		≤ 0.576 FL	≤ 0.600 FL	≤ 0.560 FL	≤ 0.585 FL	
			≤ 0.549 IPLV	≤ 0.400 IPLV	≤ 0.500 IPLV	≤ 0.380 IPLV	
≥ 600 Tons	≤ 0.570 FL	≤ 0.590 FL	≤ 0.560 FL	≤ 0.585 FL			
		≤ 0.539 IPLV	≤ 0.400 IPLV	≤ 0.500 IPLV	≤ 0.380 IPLV		
Air cooled, absorption, single effect	All capacities	COP	≥ 0.600 FL	NA <sup>c</sup>	≥ 0.600 FL	NA <sup>c</sup>	AHRI 560
Water cooled absorption, single effect	All capacities	COP	≥ 0.700 FL	NA <sup>c</sup>	≥ 0.700 FL	NA <sup>c</sup>	
Absorption, double effect, indirect fired	All capacities	COP	≥ 1.000 FL	NA <sup>c</sup>	≥ 1.000 FL	NA <sup>c</sup>	
			≥ 1.050 IPLV		≥ 1.050 IPLV		
Absorption double effect direct fired	All capacities	COP	≥ 1.000 FL	NA <sup>c</sup>	≥ 1.000 FL	NA <sup>c</sup>	
			≥ 1.000 IPLV		≥ 1.050 IPLV		

**Table 4: IECC 2015 Boiler minimum efficiency requirements (effective 1/1/2016 to 6/30/2019)**

EQUIPMENT TYPE <sup>a</sup>	SUBCATEGORY OR RATING CONDITION	SIZE CATEGORY (INPUT)	MINIMUM EFFICIENCY <sup>d, e</sup>	TEST PROCEDURE
Boilers, hot water	Gas-fired	< 300,000 Btu/h	80% AFUE	10 CFR Part 430
		≥ 300,000 Btu/h and ≤ 2,500,000 Btu/h <sup>b</sup>	80% $E_t$	10 CFR Part 431
		> 2,500,000 Btu/h <sup>a</sup>	82% $E_c$	
	Oil-fired <sup>c</sup>	< 300,000 Btu/h	80% AFUE	10 CFR Part 430
		≥ 300,000 Btu/h and ≤ 2,500,000 Btu/h <sup>b</sup>	82% $E_t$	10 CFR Part 431
		> 2,500,000 Btu/h <sup>a</sup>	84% $E_c$	
Boilers, steam	Gas-fired	< 300,000 Btu/h	75% AFUE	10 CFR Part 430
	Gas-fired- all, except natural draft	≥ 300,000 Btu/h and ≤ 2,500,000 Btu/h <sup>b</sup>	79% $E_t$	10 CFR Part 431
		> 2,500,000 Btu/h <sup>a</sup>	79% $E_t$	
	Gas-fired-natural draft	≥ 300,000 Btu/h and ≤ 2,500,000 Btu/h <sup>b</sup>	77% $E_t$	
		> 2,500,000 Btu/h <sup>a</sup>	77% $E_t$	
	Oil-fired <sup>c</sup>	< 300,000 Btu/h	80% AFUE	10 CFR Part 430
		≥ 300,000 Btu/h and ≤ 2,500,000 Btu/h <sup>b</sup>	81% $E_t$	10 CFR Part 431
		> 2,500,000 Btu/h <sup>a</sup>	81% $E_t$	

**Table 5: IECC 2015 Warm-air Furnace minimum efficiency standards (effective 1/1/2016 to 6/30/2019)**

EQUIPMENT TYPE	SIZE CATEGORY (INPUT)	SUBCATEGORY OR RATING CONDITION	MINIMUM EFFICIENCY <sup>d, e</sup>	TEST PROCEDURE <sup>a</sup>
Warm-air furnaces, gas fired	< 225,000 Btu/h	—	78% AFUE or 80% $E_t^c$	DOE 10 CFR Part 430 or ANSI Z21.47
	≥ 225,000 Btu/h	Maximum capacity <sup>c</sup>	80% $E_t^f$	ANSI Z21.47
Warm-air furnaces, oil fired	< 225,000 Btu/h	—	78% AFUE or 80% $E_t^c$	DOE 10 CFR Part 430 or UL 727
	≥ 225,000 Btu/h	Maximum capacity <sup>b</sup>	81% $E_t^g$	UL 727
Warm-air duct furnaces, gas fired	All capacities	Maximum capacity <sup>b</sup>	80% $E_c$	ANSI Z83.8
Warm-air unit heaters, gas fired	All capacities	Maximum capacity <sup>b</sup>	80% $E_c$	ANSI Z83.8
Warm-air unit heaters, oil fired	All capacities	Maximum capacity <sup>b</sup>	80% $E_c$	UL 731

**Table 6: IECC 2015 Water Heaters minimum performance (effective 1/1/2016 to 6/30/2019)**

EQUIPMENT TYPE	SIZE CATEGORY (input)	SUBCATEGORY OR RATING CONDITION	PERFORMANCE REQUIRED <sup>a, b</sup>	TEST PROCEDURE
Water heaters, electric	≤ 12 kW <sup>d</sup>	Resistance	0.97 - 0.00 132V, EF	DOE 10 CFR Part 430
	> 12 kW	Resistance	(0.3 + 27/ $V_m$ ), %/h	ANSI Z21.10.3
	≤ 24 amps and ≤ 250 volts	Heat pump	0.93 - 0.00 132V, EF	DOE 10 CFR Part 430
Storage water heaters, gas	≤ 75,000 Btu/h	≥ 20 gal	0.67 - 0.0019V, EF	DOE 10 CFR Part 430
	> 75,000 Btu/h and ≤ 155,000 Btu/h	< 4,000 Btu/h/gal	80% $E_t$ ( $Q/800 + 110 \cdot \sqrt{V}$ )SL, Btu/h	ANSI Z21.10.3
	> 155,000 Btu/h	< 4,000 Btu/h/gal	80% $E_t$ ( $Q/800 + 110 \cdot \sqrt{V}$ )SL, Btu/h	
Instantaneous water heaters, gas	> 50,000 Btu/h and < 200,000 Btu/h <sup>c</sup>	≥ 4,000 (Btu/h)/gal and < 2 gal	0.62 - 0.00 19V, EF	DOE 10 CFR Part 430
	≥ 200,000 Btu/h	≥ 4,000 Btu/h/gal and < 10 gal	80% $E_t$	ANSI Z21.10.3
	≥ 200,000 Btu/h	≥ 4,000 Btu/h/gal and ≥ 10 gal	80% $E_t$ ( $Q/800 + 110 \cdot \sqrt{V}$ )SL, Btu/h	



**Table 7: IECC 2018 ASHP Minimum Efficiency Requirements** (effective 7/1/2019 to 9/30/2022)

TABLE C403.3.2(2)  
MINIMUM EFFICIENCY REQUIREMENTS: ELECTRICALLY OPERATED UNITARY AND APPLIED HEAT PUMPS

EQUIPMENT TYPE	SIZE CATEGORY	HEATING SECTION TYPE	SUBCATEGORY OR RATING CONDITION	MINIMUM EFFICIENCY	TEST PROCEDURE <sup>a</sup>		
Air cooled (cooling mode)	< 65,000 Btu/h <sup>b</sup>	All	Split System	14.0 SEER	AHRI 210/240		
			Single Package	14.0 SEER			
Through-the-wall, air cooled	≤ 30,000 Btu/h <sup>b</sup>	All	Split System	12.0 SEER			
			Single Package	12.0 SEER			
Single-duct high-velocity air cooled	< 65,000 Btu/h <sup>b</sup>	All	Split System	11.0 SEER			
Air cooled (cooling mode)	≥ 65,000 Btu/h and < 135,000 Btu/h	Electric Resistance (or None)	Split System and Single Package	11.0 EER 12.0 IEER		AHRI 340/360	
		All other	Split System and Single Package	10.8 EER 11.8 IEER			
	≥ 135,000 Btu/h and < 240,000 Btu/h	Electric Resistance (or None)	Split System and Single Package	10.6 EER 11.6 IEER			
		All other	Split System and Single Package	10.4 EER 11.4 IEER			
	≥ 240,000 Btu/h	Electric Resistance (or None)	Split System and Single Package	9.5 EER 10.6 IEER			
		All other	Split System and Single Package	9.3 EER 9.4 IEER			
	Water to Air: Water Loop (cooling mode)	< 17,000 Btu/h	All	86°F entering water	12.2 EER		ISO 13256-1
		≥ 17,000 Btu/h and < 65,000 Btu/h	All	86°F entering water	13.0 EER		
≥ 65,000 Btu/h and < 135,000 Btu/h		All	86°F entering water	13.0 EER			
Water to Air: Ground Water (cooling mode)	< 135,000 Btu/h	All	59°F entering water	18.0 EER	ISO 13256-1		
Brine to Air: Ground Loop (cooling mode)	< 135,000 Btu/h	All	77°F entering water	14.1 EER	ISO 13256-1		
Water to Water: Water Loop (cooling mode)	< 135,000 Btu/h	All	86°F entering water	10.6 EER	ISO 13256-2		
Water to Water: Ground Water (cooling mode)	< 135,000 Btu/h	All	59°F entering water	16.3 EER			
Brine to Water: Ground Loop (cooling mode)	< 135,000 Btu/h	All	77°F entering fluid	12.1 EER			

Table 7 continued:

Air cooled (heating mode)	< 65,000 Btu/h <sup>b</sup>	—	Split System	8.2 HSPF	AHRI 210/240
		—	Single Package	8.0 HSPF	
Through-the-wall, (air cooled, heating mode)	≤ 30,000 Btu/h <sup>b</sup> (cooling capacity)	—	Split System	7.4 HSPF	
		—	Single Package	7.4 HSPF	
Small-duct high velocity (air cooled, heating mode)	< 65,000 Btu/h <sup>b</sup>	—	Split System	6.8 HSPF	
Air cooled (heating mode)	≥ 65,000 Btu/h and < 135,000 Btu/h (cooling capacity)	—	47°F db/43°F wb outdoor air	3.3 COP	
			17°Fdb/15°F wb outdoor air	2.25 COP	
	≥ 135,000 Btu/h (cooling capacity)	—	47°F db/43°F wb outdoor air	3.2 COP	
			17°Fdb/15°F wb outdoor air	2.05 COP	
Water to Air: Water Loop (heating mode)	< 135,000 Btu/h (cooling capacity)	—	68°F entering water	4.3 COP	ISO 13256-1
Water to Air: Ground Water (heating mode)	< 135,000 Btu/h (cooling capacity)	—	50°F entering water	3.7 COP	
Brine to Air: Ground Loop (heating mode)	< 135,000 Btu/h (cooling capacity)	—	32°F entering fluid	3.2 COP	
Water to Water: Water Loop (heating mode)	< 135,000 Btu/h (cooling capacity)	—	68°F entering water	3.7 COP	ISO 13256-2
Water to Water: Ground Water (heating mode)	< 135,000 Btu/h (cooling capacity)	—	50°F entering water	3.1 COP	
Brine to Water: Ground Loop (heating mode)	< 135,000 Btu/h (cooling capacity)	—	32°F entering fluid	2.5 COP	

For SI: 1 British thermal unit per hour = 0.2931 W. °C = [(°F) - 32]/1.8.

- a. Chapter 8 contains a complete specification of the referenced test procedure, including the reference year version of the test procedure.
- b. Single-phase, air-cooled heat pumps less than 65,000 Btu/h are regulated by NAECA. SEER and HSPF values are those set by NAECA.

**Table 8: IECC 2018 Electric Chillers, Air-Cooled and Water-Cooled minimum efficiencies (effective 7/1/2019 to 9/30/2022)**

TABLE C403.3.2(7)  
WATER CHILLING PACKAGES — EFFICIENCY REQUIREMENTS<sup>a, b, d</sup>

EQUIPMENT TYPE	SIZE CATEGORY	UNITS	BEFORE 1/1/2015		AS OF 1/1/2015		TEST PROCEDURE <sup>c</sup>		
			Path A	Path B	Path A	Path B			
Air-cooled chillers	< 150 Tons	EER (Btu/W)	≥ 9.562 FL	NA <sup>c</sup>	≥ 10.100 FL	≥ 9.700 FL	AHRI 550/590		
			≥ 12.500 IPLV		≥ 13.700 IPLV	≥ 15.800 IPLV			
	≥ 150 Tons		≥ 9.562 FL	NA <sup>c</sup>	≥ 10.100 FL	≥ 9.700 FL			
			≥ 12.500 IPLV		≥ 14.000 IPLV	≥ 16.100 IPLV			
Air cooled without condenser, electrically operated	All capacities	EER (Btu/W)	Air-cooled chillers without condenser shall be rated with matching condensers and complying with air-cooled chiller efficiency requirements.						
Water cooled, electrically operated positive displacement	< 75 Tons	kW/ton	≤ 0.780 FL	≤ 0.800 FL	≤ 0.750 FL	≤ 0.780 FL			
			≤ 0.630 IPLV	≤ 0.600 IPLV	≤ 0.600 IPLV	≤ 0.500 IPLV			
	≥ 75 tons and < 150 tons		≤ 0.775 FL	≤ 0.790 FL	≤ 0.720 FL	≤ 0.750 FL			
			≤ 0.615 IPLV	≤ 0.586 IPLV	≤ 0.560 IPLV	≤ 0.490 IPLV			
	≥ 150 tons and < 300 tons		≥ 0.680 FL	≥ 0.718 FL	≥ 0.660 FL	≥ 0.680 FL			
			≥ 0.580 IPLV	≥ 0.540 IPLV	≥ 0.540 IPLV	≥ 0.440 IPLV			
	≥ 300 tons and < 600 tons		≤ 0.620 FL	≤ 0.639 FL	≤ 0.610 FL	≤ 0.625 FL			
			≤ 0.540 IPLV	≤ 0.490 IPLV	≤ 0.520 IPLV	≤ 0.410 IPLV			
	≥ 600 tons		≤ 0.620 FL	≤ 0.639 FL	≤ 0.560 FL	≤ 0.585 FL			
			≤ 0.540 IPLV	≤ 0.490 IPLV	≤ 0.500 IPLV	≤ 0.380 IPLV			
	Water cooled, electrically operated centrifugal		< 150 Tons	kW/ton	≤ 0.634 FL	≤ 0.639 FL	≤ 0.610 FL	≤ 0.695 FL	
					≤ 0.596 IPLV	≤ 0.450 IPLV	≤ 0.550 IPLV	≤ 0.440 IPLV	
≥ 150 tons and < 300 tons		≤ 0.634 FL	≤ 0.639 FL		≤ 0.610 FL	≤ 0.635 FL			
		≤ 0.596 IPLV	≤ 0.450 IPLV		≤ 0.550 IPLV	≤ 0.400 IPLV			
≥ 300 tons and < 400 tons		≤ 0.576 FL	≤ 0.600 FL		≤ 0.560 FL	≤ 0.595 FL			
		≤ 0.549 IPLV	≤ 0.400 IPLV		≤ 0.520 IPLV	≤ 0.390 IPLV			
≥ 400 tons and < 600 tons		≤ 0.576 FL	≤ 0.600 FL		≤ 0.560 FL	≤ 0.585 FL			
		≤ 0.549 IPLV	≤ 0.400 IPLV		≤ 0.500 IPLV	≤ 0.380 IPLV			
≥ 600 Tons		≤ 0.570 FL	≤ 0.590 FL		≤ 0.560 FL	≤ 0.585 FL			
		≤ 0.539 IPLV	≤ 0.400 IPLV		≤ 0.500 IPLV	≤ 0.380 IPLV			
Air cooled, absorption, single effect		All capacities	COP		≥ 0.600 FL	NA <sup>c</sup>	≥ 0.600 FL	NA <sup>c</sup>	AHRI 560
Water cooled absorption, single effect		All capacities	COP		≥ 0.700 FL	NA <sup>c</sup>	≥ 0.700 FL	NA <sup>c</sup>	
Absorption, double effect, indirect fired	All capacities	COP	≥ 1.000 FL	NA <sup>c</sup>	≥ 1.000 FL	NA <sup>c</sup>			
			≥ 1.050 IPLV		≥ 1.050 IPLV				
Absorption double effect direct fired	All capacities	COP	≥ 1.000 FL	NA <sup>c</sup>	≥ 1.000 FL	NA <sup>c</sup>			
			≥ 1.000 IPLV		≥ 1.050 IPLV				

**Table 9: IECC 2018 Boiler minimum efficiency requirements** (effective 7/1/2019 to 9/30/2022)

Note Code of Federal Regulations for gas-fired hot water boilers manufactured after January 15, 2021 require <300,000Btuh hot water boilers to be 84% AFUE and <300,000 Btuh steam boilers to be 82% AFUE (10 CFR 432(e)(3)). This should be assumed baseline from 1/1/2022.

TABLE C403.3.2(5)  
MINIMUM EFFICIENCY REQUIREMENTS: GAS- AND OIL-FIRED BOILERS

EQUIPMENT TYPE <sup>a</sup>	SUBCATEGORY OR RATING CONDITION	SIZE CATEGORY (INPUT)	MINIMUM EFFICIENCY <sup>d, e</sup>	TEST PROCEDURE
Boilers, hot water	Gas-fired	< 300,000 Btu/h <sup>f, g</sup>	82% AFUE	10 CFR Part 430
		≥ 300,000 Btu/h and ≤ 2,500,000 Btu/h <sup>b</sup>	80% E <sub>t</sub>	10 CFR Part 431
		> 2,500,000 Btu/h <sup>a</sup>	82% E <sub>c</sub>	
	Oil-fired <sup>c</sup>	< 300,000 Btu/h <sup>a</sup>	84% AFUE	10 CFR Part 430
		≥ 300,000 Btu/h and ≤ 2,500,000 Btu/h <sup>b</sup>	82% E <sub>t</sub>	10 CFR Part 431
		> 2,500,000 Btu/h <sup>a</sup>	84% E <sub>c</sub>	
Boilers, steam	Gas-fired	< 300,000 Btu/h <sup>f</sup>	80% AFUE	10 CFR Part 430
	Gas-fired- all, except natural draft	≥ 300,000 Btu/h and ≤ 2,500,000 Btu/h <sup>b</sup>	79% E <sub>t</sub>	10 CFR Part 431
		> 2,500,000 Btu/h <sup>a</sup>	79% E <sub>t</sub>	
	Gas-fired-natural draft	≥ 300,000 Btu/h and ≤ 2,500,000 Btu/h <sup>b</sup>	77% E <sub>t</sub>	
		> 2,500,000 Btu/h <sup>a</sup>	77% E <sub>t</sub>	
	Oil-fired <sup>c</sup>	< 300,000 Btu/h	82% AFUE	10 CFR Part 430
		≥ 300,000 Btu/h and ≤ 2,500,000 Btu/h <sup>b</sup>	81% E <sub>t</sub>	10 CFR Part 431
		> 2,500,000 Btu/h <sup>a</sup>	81% E <sub>t</sub>	

**Table 10: IECC 2018 Warm-air Furnace minimum efficiency standards** (effective 7/1/2019 to 9/30/2022)

TABLE C403.3.2(4)  
WARM-AIR FURNACES AND COMBINATION WARM-AIR FURNACES/AIR-CONDITIONING UNITS, WARM-AIR DUCT FURNACES AND UNIT HEATERS, MINIMUM EFFICIENCY REQUIREMENTS

EQUIPMENT TYPE	SIZE CATEGORY (INPUT)	SUBCATEGORY OR RATING CONDITION	MINIMUM EFFICIENCY <sup>d, e</sup>	TEST PROCEDURE <sup>a</sup>
Warm-air furnaces, gas fired	< 225,000 Btu/h	—	80% AFUE or 80%E <sub>t</sub>	DOE 10 CFR Part 430 or ANSI Z21.47
	≥ 225,000 Btu/h	Maximum capacity <sup>c</sup>	80%E <sub>t</sub> <sup>f</sup>	ANSI Z21.47
Warm-air furnaces, oil fired	< 225,000 Btu/h	—	83% AFUE or 80%E <sub>t</sub>	DOE 10 CFR Part 430 or UL 727
	≥ 225,000 Btu/h	Maximum capacity <sup>b</sup>	81%E <sub>t</sub> <sup>g</sup>	UL 727
Warm-air duct furnaces, gas fired	All capacities	Maximum capacity <sup>b</sup>	80%E <sub>c</sub>	ANSI Z83.8
Warm-air unit heaters, gas fired	All capacities	Maximum capacity <sup>b</sup>	80%E <sub>c</sub>	ANSI Z83.8
Warm-air unit heaters, oil fired	All capacities	Maximum capacity <sup>b</sup>	80%E <sub>c</sub>	UL 731

**Table 11: IECC 2018 Water Heaters minimum performance (effective 7/1/2019 to 9/30/2022)**

TABLE C404.2  
MINIMUM PERFORMANCE OF WATER-HEATING EQUIPMENT

EQUIPMENT TYPE	SIZE CATEGORY (input)	SUBCATEGORY OR RATING CONDITION	PERFORMANCE REQUIRED <sup>a, b</sup>	TEST PROCEDURE
Water heaters, electric	≤ 12 kW <sup>d</sup>	Tabletop <sup>e</sup> , ≥ 20 gallons and ≤ 120 gallons	0.93 - 0.00132V, EF	DOE 10 CFR Part 430
		Resistance ≥ 20 gallons and ≤ 55 gallons	0.960 - 0.0003V, EF	
		Grid-enabled <sup>f</sup> > 75 gallons and ≤ 120 gallons	1.061 - 0.00168V, EF	
	> 12 kW	Resistance	(0.3 + 27/V <sub>m</sub> ), %/h	ANSI Z21.10.3
	≤ 24 amps and ≤ 250 volts	Heat pump > 55 gallons and ≤ 120 gallons	2.057 - 0.00113V, EF	DOE 10 CFR Part 430
Storage water heaters, gas	≤ 75,000 Btu/h	≥ 20 gallons and > 55 gallons	0.675 - 0.0015V, EF	DOE 10 CFR Part 430
		> 55 gallons and ≤ 100 gallons	0.8012 - 0.00078V, EF	
	> 75,000 Btu/h and ≤ 155,000 Btu/h	< 4,000 Btu/h/gal	80% E <sub>t</sub>	ANSI Z21.10.3
	> 155,000 Btu/h	< 4,000 Btu/h/gal	80% E <sub>t</sub>	
Instantaneous water heaters, gas	> 50,000 Btu/h and < 200,000 Btu/h <sup>c</sup>	≥ 4,000 (Btu/h)/gal and < 2 gal	0.82 - 0.00 19V, EF	DOE 10 CFR Part 430
	≥ 200,000 Btu/h	≥ 4,000 Btu/h/gal and < 10 gal	80% E <sub>t</sub>	ANSI Z21.10.3
	≥ 200,000 Btu/h	≥ 4,000 Btu/h/gal and ≥ 10 gal	80% E <sub>t</sub>	

**Table 12: IECC 2021 ASHP Minimum Efficiency Requirements** (expected to become effective statewide in 2023)

TABLE C403.3.2(2)  
ELECTRICALLY OPERATED AIR-COOLED UNITARY HEAT PUMPS—MINIMUM EFFICIENCY REQUIREMENTS<sup>a, d</sup>

EQUIPMENT TYPE	SIZE CATEGORY	HEADING SECTION TYPE	SUBCATEGORY OR RATING CONDITION	MINIMUM EFFICIENCY	TEST PROCEDURE <sup>e</sup>
Air cooled (cooling mode)	< 66,000 Btu/h	All	Split system, three phase and applications outside US single phase <sup>b</sup>	14.0 SEER before 1/1/2023 14.3 SEER2 after 1/1/2023	AHRI 210/240—2017 before 1/1/2023 AHRI 210/240—2023 after 1/1/2023
			Single package, three phase and applications outside US single phase <sup>b</sup>	14.0 SEER before 1/1/2023 13.4 SEER2 after 1/1/2023	
Space constrained, air cooled (cooling mode)	≤ 30,000 Btu/h	All	Split system, three phase and applications outside US single phase <sup>b</sup>	12.0 SEER before 1/1/2023 11.7 SEER2 after 1/1/2023	AHRI 210/240—2017 before 1/1/2023 AHRI 210/240—2023 after 1/1/2023
			Single package, three phase and applications outside US single phase <sup>b</sup>	12.0 SEER before 1/1/2023 11.7 SEER2 after 1/1/2023	
Single duct, high velocity, air cooled (cooling mode)	< 65,000	All	Split system, three phase and applications outside US single phase <sup>b</sup>	12.0 SEER before 1/1/2023 12.0 SEER2 after 1/1/2023	AHRI 210/240—2017 before 1/1/2023 AHRI 210/240—2023 after 1/1/2023
Air cooled (cooling mode)	≥ 65,000 Btu/h and < 135,000 Btu/h	Electric resistance (or none)	Split system and single package	11.0 EER 12.2 IEER before 1/1/2023 14.1 IEER after 1/1/2023	AHRI 340/360
		All other		10.8 EER 12.0 IEER before 1/1/2023 13.9 IEER after 1/1/2023	
	≥ 135,000 Btu/h and < 240,000 Btu/h	Electric resistance (or none)		10.6 EER 11.6 IEER before 1/1/2023 13.5 IEER after 1/1/2023	
		All other		10.4 EER 11.4 IEER before 1/1/2023 13.3 IEER after 1/1/2023	
	≥ 240,000 Btu/h	Electric resistance (or none)		9.5 EER 10.6 IEER before 1/1/2023 12.5 IEER after 1/1/2023	
		All other		9.3 EER 10.4 IEER before 1/1/2023 12.3 IEER after 1/1/2023	
Air cooled (heating mode)	< 65,000 Btu/h	All	Split system, three phase and applications outside US single phase <sup>b</sup>	8.2 HSPF before 1/1/2023 7.5 HSPF2 after 1/1/2023	AHRI 210/240—2017 before 1/1/2023 AHRI 210/240—2023 after 1/1/2023
			Single package, three phase and applications outside US single phase <sup>b</sup>	8.0 HSPF before 1/1/2023 6.7 HSPF2 after 1/1/2023	

**Table 12 continued:**

**TABLE C403.3.2(2)—continued  
ELECTRICALLY OPERATED AIR-COOLED UNITARY HEAT PUMPS—MINIMUM EFFICIENCY REQUIREMENTS<sup>a, d</sup>**

EQUIPMENT TYPE	SIZE CATEGORY	HEADING SECTION TYPE	SUBCATEGORY OR RATING CONDITION	MINIMUM EFFICIENCY	TEST PROCEDURE <sup>a</sup>
Space constrained, air cooled (heating mode)	≤ 30,000 Btu/h	All	Split system, three phase and applications outside US single phase <sup>b</sup>	7.4 HSPF before 1/1/2023 6.3 HSPF2 after 1/1/2023	AHRI 210/240—2017 before 1/1/2023 AHRI 210/240—2023 after 1/1/2023
			Single package, three phase and applications outside US single phase <sup>b</sup>	7.4 HSPF before 1/1/2023 6.3 HSPF2 after 1/1/2023	
Small duct, high velocity, air cooled (heating mode)	< 65,000 Btu/h	All	Split system, three phase and applications outside US single phase <sup>b</sup>	7.2 HSPF before 1/1/2023 6.1 HSPF2 after 1/1/2023	AHRI 210/240—2017 before 1/1/2023 AHRI 210/240—2023 after 1/1/2023
Air cooled (heating mode)	≥ 65,000 Btu/h and < 135,000 Btu/h (cooling capacity)	All	47°F db/43°F wb outdoor air	3.30 COP <sub>H</sub> before 1/1/2023 3.40 COP <sub>H</sub> after 1/1/2023	AHRI 340/360
			17°F db/15°F wb outdoor air	2.25 COP <sub>H</sub>	
	47°F db/43°F wb outdoor air		3.20 COP <sub>H</sub> before 1/1/2023 3.30 SOP <sub>H</sub> after 1/1/2023		
	17°F db/15°F wb outdoor air		2.05 COP <sub>H</sub>		
	47°F db/43°F wb outdoor air		3.20 COP <sub>H</sub>		
	17°F db/15°F wb outdoor air		2.05 COP <sub>H</sub>		
≥ 135,000 Btu/h and < 240,000 Btu/h (cooling capacity)					
≥ 240,000 Btu/h (cooling capacity)					



**Table 13: IECC 2021 Electric Chillers, Air-Cooled and Water-Cooled minimum efficiencies** (expected to become effective statewide in 2023)

**TABLE C403.3.2(3)**  
**WATER-CHILLING PACKAGES—MINIMUM EFFICIENCY REQUIREMENTS<sup>a, b, e, f</sup>**

EQUIPMENT TYPE	SIZE CATEGORY	UNITS	PATH A	PATH B	TEST PROCEDURE <sup>e</sup>
Air cooled chillers	< 150 tons	EER (Btu/Wh)	≥ 10.100 FL	≥ 9.700 FL	AHRI 550/590
			≥ 13.700 IPLV.IP	≥ 15.800 IPLV.IP	
	≥ 150 tons		≥ 10.100 FL	≥ 9.700FL	
			≥ 14.000 IPLV.IP	≥ 16.100 IPLV.IP	
Air cooled without condenser, electrically operated	All capacities	EER (Btu/Wh)	Air-cooled chillers without condenser must be rated with matching condensers and comply with air-cooled chiller efficiency requirements		AHRI 550/590
Water cooled, electrically operated positive displacement	< 75 tons	kW/ton	≤ 0.750 FL	≤ 0.780 FL	AHRI 550/590
			≤ 0.600 IPLV.IP	≤ 0.500 IPLV.IP	
	≥ 75 tons and < 150 tons		≤ 0.720 FL	≤ 0.750 FL	
			≤ 0.560 IPLV.IP	≤ 0.490 IPLV.IP	
	≥ 150 tons and < 300 tons		≤ 0.660 FL	≤ 0.680 FL	
			≤ 0.540 IPLV.IP	≤ 0.440 IPLV.IP	
	≥ 300 tons and < 600 tons		≤ 0.610 FL	≤ 0.625 FL	
			≤ 0.520 IPLV.IP	≤ 0.410 IPLV.IP	
≥ 600 tons	≤ 0.560 FL	≤ 0.585 FL			
≤ 0.500 IPLV.IP	≤ 0.380 IPLV.IP				
Water cooled, electrically operated centrifugal	< 150 tons	kW/ton	≤ 0.610 FL	≤ 0.695 FL	AHRI 550/590
			≤ 0.550 IPLV.IP	≤ 0.440 IPLV.IP	
	≥ 300 tons and < 400 tons		≤ 0.610 FL	≤ 0.635 FL	
			≤ 0.550 IPLV.IP	≤ 0.400 IPLV.IP	
	≥ 400 tons and < 600 tons		≤ 0.560 FL	≤ 0.595 FL	
			≤ 0.520 IPLV.IP	≤ 0.390 IPLV.IP	
	≥ 600 tons		≤ 0.560 FL	≤ 0.585 FL	
			≤ 0.500 IPLV.IP	≤ 0.380 IPLV.IP	
≤ 0.560 FL	≤ 0.585 FL				
≤ 0.500 IPLV.IP	≤ 0.380 IPLV.IP				
Air cooled absorption, single effect	All capacities	COP (W/W)	≥ 0.600 FL	NA <sup>d</sup>	AHRI 560
Water cooled absorption, single effect	All capacities	COP (W/W)	≥ 0.700 FL	NA <sup>d</sup>	AHRI 560
Absorption double effect, indirect fired	All capacities	COP (W/W)	≥ 1.000 FL	NA <sup>d</sup>	AHRI 560
			≥ 0.150 IPLV.IP		
Absorption double effect, direct fired	All capacities	COP (W/W)	≥ 1.000 FL	NA <sup>d</sup>	AHRI 560
			≥ 1.000 IPLV		

- a. Chapter 6 contains a complete specification of the referenced standards, which include test procedures, including the reference year version of the test procedure.
- b. The requirements for centrifugal chillers shall be adjusted for nonstandard rating conditions per Section C403.3.2.1 and are applicable only for the range of conditions listed there. The requirements for air-cooled, water-cooled positive displacement and absorption chillers are at standard rating conditions defined in the reference test procedure.
- c. Both the full-load and IPLV.IP requirements must be met or exceeded to comply with this standard. When there is a Path B, compliance can be with either Path A or Path B for any application.
- d. NA means the requirements are not applicable for Path B, and only Path A can be used for compliance.
- e. FL is the full-load performance requirements, and IPLV.IP is for the part-load performance requirements.
- f. This table is a replica of ASHRAE 90.1 Table 6.8.1-3 Water-Chilling Packages—Minimum Efficiency Requirements.



**Table 14: IECC 2021 Boiler minimum efficiency requirements** (expected to become effective statewide in 2023)

Note Code of Federal Regulations for gas -fired hot water boilers manufactured after January 15, 2021 require <300,000 Btuh hot water boilers to be 84% AFUE and <300,000 Btuh steam boilers to be 82% AFUE (10 CFR 432(e)(3)). This should be assumed baseline from 1/1/2022.

TABLE C403.3.2(6)  
GAS- AND OIL-FIRED BOILERS—MINIMUM EFFICIENCY REQUIREMENTS<sup>1</sup>

EQUIPMENT TYPE <sup>2</sup>	SUBCATEGORY OR RATING CONDITION	SIZE CATEGORY (INPUT)	MINIMUM EFFICIENCY	EFFICIENCY AS OF 3/2/2022	TEST PROCEDURE <sup>3</sup>
Boilers, hot water	Gas fired	< 300,000 Btu/h <sup>a, b</sup> for applications outside US	82% AFUE	82% AFUE	DOE 10 CFR 430 Appendix N
		≥ 300,000 Btu/h and ≤ 2,500,000 Btu/h <sup>a</sup>	80% $E_t^d$	80% $E_t^d$	DOE 10 CFR 431.86
		> 2,500,000 Btu/h <sup>b</sup>	82% $E_c^c$	82% $E_c^c$	
	Oil fired <sup>d</sup>	< 300,000 Btu/h <sup>a, b</sup> for applications outside US	84% AFUE	84% AFUE	DOE 10 CFR 430 Appendix N
		≥ 300,000 Btu/h and ≤ 2,500,000 Btu/h <sup>a</sup>	82% $E_t^d$	82% $E_t^d$	DOE 10 CFR 431.86
		> 2,500,000 Btu/h <sup>b</sup>	84% $E_c^c$	84% $E_c^c$	
Boilers, steam	Gas fired	< 300,000 Btu/h <sup>a</sup> for applications outside US	80% AFUE	80% AFUE	DOE 10 CFR 430 Appendix N
	Gas fired—all, except natural draft	≥ 300,000 Btu/h and ≤ 2,500,000 Btu/h <sup>a</sup>	79% $E_t^d$	79% $E_t^d$	DOE 10 CFR 431.86
		> 2,500,000 Btu/h <sup>b</sup>	79% $E_t^d$	79% $E_t^d$	
	Gas fired—natural draft	≥ 300,000 Btu/h and ≤ 2,500,000 Btu/h <sup>a</sup>	77% $E_t^d$	79% $E_t^d$	
		> 2,500,000 Btu/h <sup>b</sup>	77% $E_t^d$	79% $E_t^d$	
	Oil fired <sup>d</sup>	< 300,000 Btu/h <sup>a</sup> for applications outside US	82% AFUE	82% AFUE	DOE 10 CFR 430 Appendix N
		≥ 300,000 Btu/h and ≤ 2,500,000 Btu/h <sup>a</sup>	81% $E_t^d$	81% $E_t^d$	DOE 10 CFR 431.86
		> 2,500,000 Btu/h <sup>b</sup>	81% $E_t^d$	81% $E_t^d$	

**Table 15: IECC 2021 Warm-air Furnace minimum efficiency standards** (expected to become effective statewide in 2023)

TABLE C403.3.2(5)  
 WARM-AIR FURNACES AND COMBINATION WARM-AIR FURNACES/AIR-CONDITIONING UNITS,  
 WARM-AIR DUCT FURNACES AND UNIT HEATERS—MINIMUM EFFICIENCY REQUIREMENTS<sup>a</sup>

EQUIPMENT TYPE	SIZE CATEGORY (INPUT)	SUBCATEGORY OR RATING CONDITION	MINIMUM EFFICIENCY	TEST PROCEDURE <sup>a</sup>
Warm-air furnace, gas fired for application outside the US	< 225,000 Btu/h	Maximum capacity <sup>c</sup>	80% AFUE (nonweatherized) or 81% AFUE (weatherized) or 80% $E_t^{b,d}$	DOE 10 CFR 430 Appendix N or Section 2.39, Thermal Efficiency, ANSI Z21.47
Warm-air furnace, gas fired	< 225,000 Btu/h	Maximum capacity <sup>c</sup>	80% $E_t^{b,d}$ before 1/1/2023 81% $E_t^d$ after 1/1/2023	Section 2.39, Thermal Efficiency, ANSI Z21.47
Warm-air furnace, oil fired for application outside the US	< 225,000 Btu/h	Maximum capacity <sup>c</sup>	83% AFUE (nonweatherized) or 78% AFUE (weatherized) or 80% $E_t^{b,d}$	DOE 10 CFR 430 Appendix N or Section 42, Combustion, UL 727
Warm-air furnace, oil fired	< 225,000 Btu/h	Maximum capacity <sup>c</sup>	80% $E_t$ before 1/1/2023 82% $E_t^d$ after 1/1/2023	Section 42, Combustion, UL 727
Electric furnaces for applications outside the US	< 225,000 Btu/h	All	96% AFUE	DOE 10 CFR 430 Appendix N
Warm-air duct furnaces, gas fired	All capacities	Maximum capacity <sup>c</sup>	80% $E_c^e$	Section 2.10, Efficiency, ANSI Z83.8
Warm-air unit heaters, gas fired	All capacities	Maximum capacity <sup>c</sup>	80% $E_c^{e,f}$	Section 2.10, Efficiency, ANSI Z83.8
Warm-air unit heaters, oil fired	All capacities	Maximum capacity <sup>c</sup>	80% $E_c^{e,f}$	Section 40, Combustion, UL 731

**Table 16: IECC 2021 Water Heaters minimum performance** (expected to become effective statewide in 2023)

**TABLE C404.2  
MINIMUM PERFORMANCE OF WATER-HEATING EQUIPMENT**

EQUIPMENT TYPE	SIZE CATEGORY (input)	SUBCATEGORY OR RATING CONDITION	PERFORMANCE REQUIRED <sup>a, b</sup>	TEST PROCEDURE
Water heaters, electric	≤ 12 kW <sup>d</sup>	Tabletop <sup>e</sup> , ≥ 20 gallons and ≤ 120 gallons	0.93 – 0.00132V, EF	DOE 10 CFR Part 430
		Resistance ≥ 20 gallons and ≤ 55 gallons	0.960 – 0.0003V, EF	
		Grid-enabled <sup>f</sup> > 75 gallons and ≤ 120 gallons	1.061 – 0.00168V, EF	
	> 12 kW	Resistance	(0.3 + 27/V <sub>m</sub> ), %/h	ANSI Z21.10.3
	≤ 24 amps and ≤ 250 volts	Heat pump > 55 gallons and ≤ 120 gallons	2.057 – 0.00113V, EF	DOE 10 CFR Part 430
Storage water heaters, gas	≤ 75,000 Btu/h	≥ 20 gallons and ≤ 55 gallons	0.675 – 0.0015V, EF	DOE 10 CFR Part 430
		> 55 gallons and ≤ 100 gallons	0.8012 – 0.00078V, EF	
	> 75,000 Btu/h and ≤ 155,000 Btu/h	< 4,000 Btu/h/gal	80% E <sub>t</sub> (Q/800 + 110.√V̄)SL, Btu/h	ANSI Z21.10.3
> 155,000 Btu/h	< 4,000 Btu/h/gal	80% E <sub>t</sub> (Q/800 + 110.√V̄)SL, Btu/h		
Instantaneous water heaters, gas	> 50,000 Btu/h and < 200,000 Btu/h <sup>e</sup>	≥ 4,000 Btu/h/gal and < 2 gal	0.82 – 0.0019V, EF	DOE 10 CFR Part 430
	≥ 200,000 Btu/h	≥ 4,000 Btu/h/gal and < 10 gal	80% E <sub>t</sub>	ANSI Z21.10.3
	≥ 200,000 Btu/h	≥ 4,000 Btu/h/gal and ≥ 10 gal	80% E <sub>t</sub> (Q/800 + 110.√V̄)SL, Btu/h	
Storage water heaters, oil	≤ 105,000 Btu/h	≥ 20 gal and ≤ 50 gallons	0.68 – 0.0019V, EF	DOE 10 CFR Part 430
	≥ 105,000 Btu/h	< 4,000 Btu/h/gal	80% E <sub>t</sub> (Q/800 + 110.√V̄)SL, Btu/h	ANSI Z21.10.3
Instantaneous water heaters, oil	≤ 210,000 Btu/h	≥ 4,000 Btu/h/gal and < 2 gal	0.59 – 0.0019V, EF	DOE 10 CFR Part 430
	> 210,000 Btu/h	≥ 4,000 Btu/h/gal and < 10 gal	80% E <sub>t</sub>	ANSI Z21.10.3
	> 210,000 Btu/h	≥ 4,000 Btu/h/gal and ≥ 10 gal	78% E <sub>t</sub> (Q/800 + 110.√V̄)SL, Btu/h	
Hot water supply boilers, gas and oil	≥ 300,000 Btu/h and < 12,500,000 Btu/h	≥ 4,000 Btu/h/gal and < 10 gal	80% E <sub>t</sub>	ANSI Z21.10.3
Hot water supply boilers, gas	≥ 300,000 Btu/h and < 12,500,000 Btu/h	≥ 4,000 Btu/h/gal and ≥ 10 gal	80% E <sub>t</sub> (Q/800 + 110.√V̄)SL, Btu/h	
Hot water supply boilers, oil	> 300,000 Btu/h and < 12,500,000 Btu/h	> 4,000 Btu/h/gal and > 10 gal	78% E <sub>t</sub> (Q/800 + 110.√V̄)SL, Btu/h	

Time of Sale: The baseline for this measure is a new replacement unit of the same system type as the existing unit, meeting the minimum standard efficiencies provided above.

Early replacement / Retrofit: The baseline for this measure is the efficiency of the *existing* heating, cooling and hot water equipment for the assumed remaining useful life of the existing unit, and a new baseline heating and cooling system for the remainder of the measure life (as provided in table above).

#### DEEMED LIFETIME OF EFFICIENT EQUIPMENT

The expected measure life of the ground source heat pump is assumed to be 25 years.<sup>953</sup>

The expected measure life of the ground loop field is assumed to be 50 years.<sup>954</sup>

For early replacement, the remaining life of existing equipment is assumed to be 6 years for ASHP and Central AC, 7 years for furnace, 8 years for boilers and GSHP,<sup>955</sup> and 25 years for electric resistance.<sup>956</sup>

#### DEEMED MEASURE COST

New Construction and Time of Sale: Incremental costs of the Ground Source Heat Pump should be used. This would be the actual installed cost of the Ground Source Heat Pump, well drilling, building retrofit, and system commissioning costs (default of \$10,923/ton),<sup>957</sup> minus the assumed installation cost of the baseline equipment (\$6562 + \$600 for ASHP,<sup>958</sup> or \$12.43/kBtu capacity for a new baseline efficient furnace or \$19.33/kBtu capacity for a new efficient steam boiler or \$21.27/kBtu capacity for a new efficient hot water boiler,<sup>959</sup> and \$1,539/ton for new baseline chiller replacement<sup>960</sup>).

Early Replacement: The actual installed cost of the Ground Source Heat Pump should be used (default cost for total system retrofit provided above). The assumed deferred cost (after 8 years) of replacing existing equipment with a new baseline unit is assumed to be \$7,527 + \$688 for a new baseline Air Source Heat Pump, or \$12.43/kBtu capacity for a new baseline efficient furnace or \$19.33/kBtu capacity for a new efficient steam boiler or \$21.27/kBtu capacity for a new efficient hot water boiler and \$1,539/ton for new baseline chiller replacement. This future cost should be discounted to present value using the nominal societal discount rate.

#### LOADSHAPE

Loadshape C04 – Commercial Electric Heating (if replacing building with no existing cooling)

Loadshape C05 - Commercial Electric Heating and Cooling

Note for the purpose of cost effectiveness screening for a fuel switch scenario, the heating kWh increase and cooling kWh decrease should be calculated separately such that the appropriate loadshape (i.e., Loadshape C04 - Commercial Electric Heating and Loadshape C03 – Commercial Cooling respectively) can be applied.

#### COINCIDENCE FACTOR

The summer peak coincidence factor for cooling is provided in two different ways below. The first is used to estimate peak savings during the utility peak hour and is most indicative of actual peak benefits, and the second represents the *average* savings over the defined summer peak period and is presented so that savings can be bid into PJM's

---

<sup>953</sup> System life of indoor components as per US DOE estimates from the Office of Energy Efficiency & Renewable Energy. The ground loop has a much longer life, but the compressor and other mechanical components are the same as an ASHP.

<sup>954</sup> U.S. DOE Office of Energy Efficiency & Renewable Energy, Energy Saver details and descriptions for Geothermal Heat Pumps

<sup>955</sup> Assumed to be one third of effective useful life of replaced equipment.

<sup>956</sup> Assume full measure life (16 years) for replacing electric resistance as we would not expect that resistance heat would fail during the lifetime of the efficient measure.

<sup>957</sup> Average calculated based on reviewing cost information received from Chicagoland GSHP installers.

<sup>958</sup> Assumed consistent with Residential assumptions - Full install ASHP costs are based upon data provided by Ameren. See 'ASHP Costs\_06242022'.

<sup>959</sup> Average calculated based on RSMMeans Mechanical Cost Data 2015.

<sup>960</sup> Average calculated based on RSMMeans Mechanical Cost Data 2015 for Scroll, air cooled condenser chillers.

capacity market. Both values provided are based on analysis of Itron eShape data for Missouri, calibrated to Illinois loads, supplied by Ameren.

$$\begin{aligned} CF_{SSP} &= \text{Summer System Peak Coincidence Factor for Commercial cooling (during system peak hour)} \\ &= 91.3\% \text{ }^{961} \end{aligned}$$

$$\begin{aligned} CF_{PJM} &= \text{PJM Summer Peak Coincidence Factor for Commercial cooling (average during peak period)} \\ &= 47.8\% \text{ }^{962} \end{aligned}$$

---



---

### Algorithm

---

#### CALCULATION OF ENERGY SAVINGS

##### ELECTRIC ENERGY SAVINGS AND FOSSIL FUEL SAVINGS

###### Non-fuel switch measures:

$$\Delta kWh = [\text{Cooling savings}] + [\text{Heating savings}] + [\text{DHW savings}]$$

$$\text{Cooling Savings} = (\text{Capacity}_{\text{cool}} * \text{EFLH}_{\text{Cool}} * (1/\text{EER2}_{\text{base}} - 1/\text{EER2}_{\text{GSHP}}))/1000$$

$$\text{Heating Savings} = (\text{Capacity}_{\text{Heat}} * \text{EFLH}_{\text{Heat}} * (1/\text{HSPF2}_{\text{base}} - 1/(\text{COP}_{\text{GSHP}} * 3.412)))/1000$$

$$\text{DHW Savings} = \text{Elec}_{\text{DHW}} * (\% \text{DHW} * ((1/\text{EF}_{\text{elecbase}}) * \text{HotWaterUse}_{\text{Gallon}} * \gamma_{\text{Water}} * (\text{T}_{\text{out}} - \text{T}_{\text{in}}) * 1/3412))$$

###### Fuel switch measures:

Fuel switch measures must produce positive total lifecycle energy savings (i.e., reduction in Btus at the premises) in order to qualify. This is determined as follows (note for early replacement measures the lifetime savings should be calculated by calculating savings for the remaining useful life of the existing equipment and for the remaining measure life):

$$\text{SiteEnergySavings (MMBTUs)} = \text{FuelSwitchSavings} + \text{NonFuelSwitchSavings}$$

$$\text{FuelSwitchSavings} = \text{GasHeatReplaced} - \text{GSHPSiteHeatConsumed}$$

$$\text{NonFuelSwitchSavings} = \text{FurnaceFanSavings} + \text{GSHPSiteCoolingImpact} + \text{GSHPSiteWaterImpact}$$

$$\text{GasHeatReplaced} = (\text{HeatLoad} * 1/\text{AFUE}_{\text{base}}) / 1,000,000$$

$$\text{FurnaceFanSavings} = (\text{FurnaceFlag} * \text{HeatLoad} * 1/\text{AFUE}_{\text{base}} * F_e) / 1,000,000$$

$$\text{GSHPSiteHeatConsumed} = (\text{HeatLoad} * 1/\text{COP}_{\text{GSHP}}) / 1,000,000$$

$$\text{GSHPSiteCoolingImpact} = (\text{EFLH}_{\text{cool}} * \text{Capacity}_{\text{Cool}} * (1/\text{EER2}_{\text{base}} - 1/\text{EER2}_{\text{GSHP}})/1000 * 3412) / 1,000,000$$

$$\text{GSHPSiteWaterImpact}_{\text{Gas}} = (\% \text{DHWD} \text{Displaced} * ((1/\text{EF}_{\text{Gas}} * \text{GPD} * \text{Household} * 365.25 * \gamma_{\text{Water}} * (\text{T}_{\text{OUT}} - \text{T}_{\text{IN}}) * 1.0) / 1,000,000$$

$$\text{GSHPSiteWaterImpact}_{\text{Electric}} = (\% \text{DHWD} \text{Displaced} * ((1/\text{EF}_{\text{Elec}} * \text{GPD} * \text{Household} * 365.25 * \gamma_{\text{Water}} * (\text{T}_{\text{OUT}} - \text{T}_{\text{IN}}) * 1.0) / 1,000,000$$

If SiteEnergySavings calculated above is positive, the measure is eligible.

<sup>961</sup> Based on analysis of Itron eShape data for Missouri, calibrated to Illinois loads, supplied by Ameren. The AC load during the utility's peak hour is divided by the maximum AC load during the year.

<sup>962</sup> Based on analysis of Itron eShape data for Missouri, calibrated to Illinois loads, supplied by Ameren. The average AC load over the PJM peak period (1-5pm, M-F, June through August) is divided by the maximum AC load during the year.

The appropriate savings claim is dependent on which utilities are supporting the measure as provided in a table below:

Measure supported by:	Electric Utility claims (kWh):	Gas Utility claims (therms):
Electric utility only	SiteEnergySavings * 1,000,000/3,412	N/A
Electric and gas utility (Note utilities may make alternative agreements to how savings are allocated as long as total MMBtu savings remains the same).	%IncentiveElectric * SiteEnergySavings * 1,000,000/3,412	%IncentiveGas * SiteEnergySavings * 10
Gas utility only	N/A	SiteEnergySavings * 10

Note for Early Replacement measures, the efficiency terms of the existing unit should be used for the remaining useful life of the existing equipment (6 years for ASHP and Central AC, 6 years for furnace, 8 years for boilers or GSHP, 15 years for electric resistance), and the efficiency terms for a new baseline unit should be used for the remaining years of the measure. See assumptions below.

Where:

Capacity<sub>cool</sub> = Cooling Output Capacity of Ground Source Heat Pump (Btu/hr)  
= Actual installed

EFLH<sub>cool</sub> = Cooling Equivalent Full Load Hours  
Dependent on building type and Existing Buildings or New Construction, provided in section 4.4 HVAC End Use

EER2<sub>Base</sub> = Energy Efficiency Ratio (EER2) of existing cooling unit (kBtu/hr / kW).  
For early replacement, use actual EER2 rating for the remaining useful life of the existing equipment (6 years for ASHP and Central AC, 8 years for GSHP). If EER2 unknown but SEER2 available, convert using the equation:<sup>963</sup>  $EER2_{exist} = (-0.02 * SEER2_{exist}^2) + (1.12 * SEER2_{exist})$ .

For TOS, NC, and the remaining measure life of early replacement, use minimum standard efficiencies as specified in tables in 'Definition of Baseline Equipment' section.

EER2<sub>GSHP</sub> = Part Load Energy Efficiency Ratio efficiency of efficient GSHP unit<sup>964</sup>  
= Actual installed

HeatLoad = Calculated heat load for the building  
= EFLH<sub>Heat</sub> \* Capacity<sub>Heat</sub>

Capacity<sub>Heat</sub> = Heating Output Capacity of Ground Source Heat Pump (Btu/hr)  
= Actual installed

EFLH<sub>Heat</sub> = Heating Equivalent Full Load Hours of heat pump  
Dependent on building type and Existing Buildings or New Construction, provided in section 4.4 HVAC End Use

HSPF2<sub>Base</sub> = Heating System Performance Factor of baseline electric heating system (kBtu/kWh)

<sup>963</sup> From Wassmer, M. (2003). A Component-Based Model for Residential Air Conditioner and Heat Pump Energy Calculations. Masters Thesis, University of Colorado at Boulder.

<sup>964</sup> From Res GSHP measure of the IL-TRM: As per conversations with David Buss territory manager for Connor Co, the EER rating of an ASHP equate most appropriately with the full load EER of a GSHP.

For early replacement, use actual HSPF2 rating for the remaining useful life of the existing equipment (6 years for ASHP and Central AC, 8 years for GSHP or 15 years for electric resistance). For electric resistance, assume 3.41.<sup>965</sup>

For TOS, NC, and the remaining measure life of early replacement, use minimum standard efficiencies as specified in tables in ‘Definition of Baseline Equipment’ section.

- COP<sub>GSHP</sub> = Part Load Coefficient of Performance of efficient GSHP<sup>966</sup>  
= Actual installed
- 3.412 = Constant to convert the COP of the unit to the Heating Season Performance Factor (HSPF)
- EleC<sub>DHW</sub> = 1 if building has electric DHW  
= 0 if building has non electric DHW  
= 0 if one to one replacement of existing Ground Source Heat Pump
- %DHW = Percentage of total DHW load that the GSHP will provide  
= Actual if known  
= If unknown and if desuperheater installed, assume 44%<sup>967</sup>  
= 0% if no desuperheater installed
- EF<sub>elecbase</sub> = Energy Factor of baseline electric DHW  
= Actual. If unknown or for new construction, assume federal standard as defined in applicable table in ‘Definition of Baseline Equipment’ section.
- HotWaterUse<sub>Gallon</sub> = Estimated annual hot water consumption (gallons)  
= Actual if possible to provide reasonable custom estimate. If not, two methodologies are provided to develop an estimate:
  1. Consumption per usable storage tank capacity  
= Capacity \* Consumption/cap

Where:

Capacity = Usable capacity of hot water storage tank in gallons  
= Actual

Consumption/cap = Estimate of consumption per gallon of usable tank capacity, based on building type:<sup>968</sup>

Building Type <sup>969</sup>	Consumption/Cap
Convenience	528
Education	568
Grocery	528

<sup>965</sup> Electric resistance has a COP of 1.0 which equals 1/0.293 = 3.41 HSPF.

<sup>966</sup> As per Res GSHP measure.

<sup>967</sup> Assumes that the desuperheater can provide two thirds of hot water needs for eight months of the year (2/3 \* 2/3 = 44%). Based on input from Doug Dougherty, Geothermal Exchange Organization.

<sup>968</sup> Methodology based on Cadmus analysis. Annual hot water usage in gallons based on CBECS (2012) and RECS (2009) consumption data of East North Central (removed outliers of 1,000 kBtu/h or less) to calculate hot water usage. Annual hot water gallons per tank size gallons based on the tank sizing methodology found in ASHRAE 2011 HVAC Applications. Chapter 50 Service Water Heating. Demand assumptions (gallons per day) for each building type based on ASHRAE Chapter 50 and to LBNL White Paper. LBL-37398 Technology Data Characterizing Water Heating in Commercial Buildings: Application to End Use Forecasting. Assumes hot water heater efficiency of 80%.

<sup>969</sup> According to CBECS 2012 “Lodging” buildings include Dormitories, Hotels, Motel or Inns and other Lodging and “Nursing” buildings include Assisted Living and Nursing Homes.

Building Type <sup>969</sup>	Consumption/Cap
Health	788
Large Office	511
Large Retail	528
Lodging	715
Other Commercial	341
Restaurant	622
Small Office	511
Small Retail	528
Warehouse	341
Nursing	672
Multi-Family	894

2. Consumption per unit area by building type  
 = (Area/1000) \* Consumption/1,000 sq.ft.

Where:

Area = Area in sq.ft that is served by DHW boiler  
 = Actual

Consumption/1,000 sq.ft. = Estimate of DHW consumption per 1,000 sq.ft. based on building type.<sup>970</sup>

Building Type <sup>971</sup>	Consumption/1,000 sq.ft.
Convenience	4,594
Education	7,285
Grocery	697
Health	24,540
Large Office	1,818
Large Retail	1,354
Lodging	29,548
Other Commercial	3,941
Restaurant	44,439
Small Office	1,540
Small Retail	6,111
Warehouse	1,239
Nursing	30,503
Multi-Family	15,434

$\gamma_{\text{Water}}$  = Density of water  
 = 8.33 pounds per gallon

$T_{\text{out}}$  = Tank temperature

<sup>970</sup> Methodology based on Cadmus analysis. Annual hot water usage in gallons based on CBECS (2012) and RECS (2009) consumption data of East North Central (removed outliers of 1,000 kBtu/h or less) to calculate hot water usage. Annual hot water gallons per tank size gallons based on the tank sizing methodology found in ASHRAE 2011 HVAC Applications. Chapter 50 Service Water Heating. Demand assumptions (gallons per day) for each building type based on ASHRAE Chapter 50 and to LBNL White Paper. LBL-37398 Technology Data Characterizing Water Heating in Commercial Buildings: Application to End Use Forecasting. Assumes hot water heater efficiency of 80%.

<sup>971</sup> According to CBECS 2012 “Lodging” buildings include Dormitories, Hotels, Motel or Inns and other Lodging and “Nursing” buildings include Assisted Living and Nursing Homes.



	= 125°F
$T_{in}$	= Incoming water temperature from well or municipal system = 50.7°F <sup>972</sup>
1	= Heat Capacity of water (1 Btu/lb·°F)
3.412	= Conversion from Btu to kWh
$AFUE_{base}$	= Baseline Annual Fuel Utilization Efficiency Rating. For early replacement measures, use actual AFUE rating for the remaining useful life of the existing equipment (6 years for furnace, 8 years for boilers).  For TOS, NC, and the remaining measure life of early replacement, use minimum standard efficiencies as specified in tables in 'Definition of Baseline Equipment' section.
FurnaceFlag	= 1 if system replaced is a gas furnace, 0 if not.
$F_e$	= Furnace Fan energy consumption as a percentage of annual fuel consumption = 7.7% <sup>973</sup>
$EF_{GasBase}$	= Energy factor of Baseline natural gas DHW heater  = Actual. If unknown or New Construction, assume federal standard as defined in applicable table in 'Definition of Baseline Equipment' section.
3412	= Btu per kWh
%IncentiveElectric	= % of total incentive paid by electric utility  = Actual
%IncentiveGas	= % of total incentive paid by gas utility  = Actual

---

<sup>972</sup> Table 4 in Chen, et. al., "Calculating Average Hot Water Mixes of Residential Plumbing Fixtures", June 2020, reports a value of 50.7°F for inlet water temperature for U.S. Census Division 3.

<sup>973</sup>  $F_e$  is estimated using TRM models for the three most popular building types for programmable thermostats: low-rise office (10.2%), sit-down restaurant (8.6%), and retail – strip mall (4.4%). 7.7% reflects the average  $F_e$  of the three building types. See "Fan Energy Factor Example Calculation 2021-06-23.xlsx" for reference.

**Non-Fuel Switch Illustrative Examples**

**New Construction using ASHP baseline:**

**For example**, a 10 ton closed loop unit with Part Load EER rating of 20 and Part Load COP of 4.4, with desuperheater installed, and with a 100 gallon electric water heater in an Assisted living building in Chicago:

$$\begin{aligned} \Delta kWh &= [120,000 * 1,457 * (1/11 - 1/20) / 1000] + [1,646 * 120,000 * (1/11 - 1/(4.4*3.412)) / 1000] \\ &+ [1 * 0.44 * ((1/0.9568 * (100*672) * 8.33 * (125-50.7) * 1)/3412)] \\ &= 7,153 + 4,800 + 5,606 = 17,559 kWh \end{aligned}$$

**Early Replacement:**

**For example**, a 10 ton closed loop unit with Part Load EER rating of 20 and Part Load COP of 4.4 and with desuperheater installed in in an Assisted living building in Chicago with a 100 gallon electric water heater, replacing an existing working Air Source Heat Pump with efficiency ratings of 8.2 EER and 7.7 HSPF:

$$\begin{aligned} \Delta kWh \text{ for remaining life of existing unit (1st 8 years):} \\ &= [120,000 * 1,457 * (1/8.2 - 1/20) / 1000] + [1,646 * 120,000 * (1/7.7 - 1/(4.4*3.412)) / 1000] \\ &+ [1 * 0.44 * ((1/0.9568 * (100*672) * 8.33 * (125-50.7) * 1)/3412)] \\ &= 12,580 + 12,495 + 5606 = 30,681 kWh \end{aligned}$$

$$\begin{aligned} \Delta kWh \text{ for remaining measure life (next 17 years):} \\ &= [120,000 * 1,457 * (1/11 - 1/20) / 1000] + [1,646 * 120,000 * (1/11 - 1/(4.4*3.412)) / 1000] \\ &+ [1 * 0.44 * ((1/0.9568 * (100*672) * 8.33 * (125-50.7) * 1)/3412)] \\ &= 7,153 + 4,800 + 5,606 = 17,559 kWh \end{aligned}$$

**Fuel Switch Illustrative Example**

*[for illustrative purposes a 50:50 Incentive is used for joint programs]*

**Early Replacement fuel switch:**

A 10 ton closed loop unit with Part Load EER rating of 20 and Part Load COP of 4.4 in an Assisted Living building in Chicago with a 100 gallon gas water heater replaces an existing working natural gas boiler with 75% efficiency and central AC of 9.5 EER, and desuperheater installed with natural gas existing DHW heater:

$$\begin{aligned} \text{LifetimeSiteEnergySavings (MMBTUs)} &= \text{LifetimeGasHeatReplaced} + \text{LifetimeFurnaceFanSavings} - \\ &\text{LifetimeGSHPSiteHeatConsumed} + \text{LifetimeGSHPSiteCoolingImpact} + \\ &\text{LifetimeGSHPSiteWaterImpact} \end{aligned}$$

$$\begin{aligned} \text{LifetimeGasHeatReplaced} &= ((\text{HeatLoad} * 1/\text{AFUE}_{\text{exist}}) / 1,000,000 * 8 \text{ years}) + ((\text{HeatLoad} * \\ &1/\text{AFUE}_{\text{base}}) / 1,000,000 * 17 \text{ years}) \\ &= ((120,000 * 1,646 * 1/0.75) / 1,000,000 * 8) + ((120,000 * 1,646 * 1/0.8) / 1,000,000 * 17) \\ &= 6304.2 \text{ MMBtu} \end{aligned}$$

$$\begin{aligned} \text{LifetimeFurnaceFanSavings} &= ((\text{FurnaceFlag} * \text{HeatLoad} * 1/\text{AFUE}_{\text{exist}} * F_e) / 1,000,000 * 8 \text{ years}) \\ &+ ((\text{FurnaceFlag} * \text{HeatLoad} * 1/\text{AFUE}_{\text{base}} * F_{e\_New}) / 1,000,000 * 17 \text{ years}) \\ &= 0 \text{ MMBtu} \end{aligned}$$

$$\begin{aligned} \text{LifetimeGSHPSiteHeatConsumed} &= (\text{HeatLoad} * 1/\text{COP}_{\text{GSHP}}) / 1,000,000 * 25 \text{ years} \\ &= (120,000 * 1,646 * 1/4.4) / 1,000,000 * 25 \\ &= 1122.3 \text{ MMBtu} \end{aligned}$$

**Fuel Switch Illustrative Example continued**

$$\text{LifetimeGSHPSiteCoolingImpact} = \left( \frac{((\text{EFLH}_{\text{cool}} * \text{Capacity}_{\text{cool}} * (1/\text{EER}_{\text{exist}} - 1/\text{EER}_{\text{GSHP}}))/1000 * 3412) / 1,000,000 * 6 \text{ years}}{1,000,000 * 19 \text{ years}} \right) + \left( \frac{((\text{EFLH}_{\text{cool}} * \text{Capacity}_{\text{cool}} * (1/\text{EER}_{\text{base}} - 1/\text{EER}_{\text{GSHP}}))/1000 * 3412) / 1,000,000 * 19 \text{ years}}{1,000,000 * 19 \text{ years}} \right)$$

$$= \left( \frac{((120000 * 1,457 * (1/9.5 - 1/20)) / 1000 * 3412) / 1,000,000 * 6}{1,000,000 * 19} \right) + \left( \frac{((120000 * 1,457 * (1/11 - 1/20)) / 1000 * 3412) / 1,000,000 * 19}{1,000,000 * 19} \right)$$

$$= 661.5 \text{ MMBtu}$$

$$\text{LifetimeGSHPSiteWaterImpact}_{\text{Gas}} = \left( \frac{(\% \text{DHWD} \text{Displaced} * ((1/\text{EF}_{\text{Gas}} * \text{GPD} * \text{Household} * 365.25 * \gamma_{\text{Water}} * (T_{\text{OUT}} - T_{\text{IN}}) * 1.0) / 1,000,000) * 25 \text{ years}}{1,000,000} \right)$$

$$= (0.44 * (1/0.8 * (100*672) * 8.33 * (125-50.7) * 1) / 1,000,000) * 25$$

$$= 571.9 \text{ MMBtu}$$

$$\text{LifetimeSiteEnergySavings (MMBTUs)} = 6304.2 + 0 - 1122.3 + 661.5 + 571.9 = 6,415 \text{ MMBtu [Measure is eligible]}$$

First 6 years:

$$\text{SiteEnergySavings\_FirstYear (MMBTUs)} = \text{GasHeatReplaced} + \text{FurnaceFanSavings} - \text{GSHPSiteHeatConsumed} + \text{GSHPSiteCoolingImpact} + \text{GSHPSiteWaterImpact}$$

$$\text{GasHeatReplaced} = (\text{HeatLoad} * 1/\text{AFUE}_{\text{exist}}) / 1,000,000$$

$$= (120,000 * 1,646 * 1/0.75) / 1,000,000$$

$$= 263.4 \text{ MMBtu}$$

$$\text{FurnaceFanSavings} = (\text{FurnaceFlag} * \text{HeatLoad} * 1/\text{AFUE}_{\text{exist}} * F_e) / 1,000,000$$

$$= 0 \text{ MMBtu}$$

$$\text{GSHPSiteHeatConsumed} = (\text{HeatLoad} * 1/\text{COP}_{\text{GSHP}}) / 1,000,000$$

$$= (120,000 * 1,646 * 1/4.4) / 1,000,000$$

$$= 44.9 \text{ MMBtu}$$

$$\text{GSHPSiteCoolingImpact} = \left( \frac{((\text{EFLH}_{\text{cool}} * \text{Capacity}_{\text{cool}} * (1/\text{EER}_{\text{exist}} - 1/\text{EER}_{\text{GSHP}}))/1000 * 3412) / 1,000,000}{1,000,000} \right)$$

$$= \left( \frac{((120000 * 1,457 * (1/9.5 - 1/20)) / 1000 * 3412) / 1,000,000}{1,000,000} \right)$$

$$= 33.0 \text{ MMBtu}$$

$$\text{GSHPSiteWaterImpact}_{\text{Gas}} = \left( \frac{(\% \text{DHWD} \text{Displaced} * ((1/\text{EF}_{\text{Gas}} * \text{GPD} * \text{Household} * 365.25 * \gamma_{\text{Water}} * (T_{\text{OUT}} - T_{\text{IN}}) * 1.0) / 1,000,000) * 25 \text{ years}}{1,000,000} \right)$$

$$= (0.44 * (1/0.8 * (100*672) * 8.33 * (125-50.7) * 1) / 1,000,000) * 25$$

$$= 22.9 \text{ MMBtu}$$

$$\text{SiteEnergySavings\_FirstYear (MMBTUs)} = 263.4 + 0 - 44.9 + 33 + 22.9 = 274.4 \text{ MMBtu}$$

**Fuel Switch Illustrative Example continued**

Remaining 10 years:

$$\text{SourceEnergySavings\_PostAdj (MMBTUs)} = \text{GasHeatReplaced} + \text{FurnaceFanSavings} - \text{GSHPSourceHeatConsumed} + \text{GSHPSourceCoolingImpact} + \text{GSHPSourceWaterImpact}$$

$$\begin{aligned} \text{GasHeatReplaced} &= (\text{HeatLoad} * 1/\text{AFUE}_{\text{exist}}) / 1,000,000 \\ &= (120,000 * 1,646 * 1/0.8) / 1,000,000 \\ &= 246.9 \text{ MMBtu} \end{aligned}$$

$$\begin{aligned} \text{FurnaceFanSavings} &= (\text{FurnaceFlag} * \text{HeatLoad} * 1/\text{AFUE}_{\text{exist}} * F_e) / 1,000,000 \\ &= 0 \text{ MMBtu} \end{aligned}$$

$$\begin{aligned} \text{GSHPSiteHeatConsumed} &= (\text{HeatLoad} * 1/\text{COP}_{\text{GSHP}}) / 1,000,000 \\ &= (120,000 * 1,646 * 1/4.4) / 1,000,000 \\ &= 44.9 \text{ MMBtu} \end{aligned}$$

$$\begin{aligned} \text{GSHPSiteCoolingImpact} &= ((\text{EFLH}_{\text{cool}} * \text{Capacity}_{\text{Cool}} * (1/\text{EER}_{\text{exist}} - 1/\text{EER}_{\text{GSHP}})) / 1000 * 3412) / 1,000,000 \\ &= ((120000 * 1,457 * (1/11 - 1/20)) / 1000 * 3412) / 1,000,000 \\ &= 24.4 \text{ MMBtu} \end{aligned}$$

$$\begin{aligned} \text{GSHPSiteWaterImpact}_{\text{Gas}} &= (\% \text{DHWDisplaced} * ((1/\text{EF}_{\text{Gas}} * \text{GPD} * \text{Household} * 365.25 * \gamma_{\text{Water}} * (T_{\text{OUT}} - T_{\text{IN}}) * 1.0) / 1,000,000 \\ &= (0.44 * (1/0.8 * (100 * 672) * 8.33 * (125 - 50.7) * 1) / 1,000,000 \\ &= 22.9 \text{ MMBtu} \end{aligned}$$

$$\text{SourceEnergySavings\_PostAdj (MMBTUs)} = 246.9 + 0 - 44.9 + 24.4 + 22.9 = 249.3 \text{ MMBtu}$$

Savings would be claimed as follows:

Measure supported by:	Electric Utility claims:	Gas Utility claims:
Electric utility only	First 6 years: $274.4 * 1,000,000 / 3412$ = 80,422 kWh Remaining 10 years: $249.3 * 1,000,000 / 3412$ = 73,066 kWh	N/A
Electric and gas utility	First 6 years: $0.5 * 274.4 * 1,000,000 / 3412$ = 40,211 kWh Remaining 10 years: $0.5 * 249.3 * 1,000,000 / 3412$ = 36,533 kWh	First 6 years: $0.5 * 274.4 * 10$ = 1372 Therms Remaining 10 years: $0.5 * 249.3 * 10$ = 1247 Therms
Gas utility only	N/A	First 6 years: $274.4 * 10$ = 2744 Therms Remaining 10 years: $249.3 * 10$ = 2493 Therms

### SUMMER COINCIDENT PEAK DEMAND SAVINGS

$$\Delta kW = (\text{Capacity}_{\text{Cool}} * (1/\text{EER}_{2\text{base}} - 1/\text{EER}_{2\text{GSHP}}))/1000 * \text{CF}$$

Where:

$\text{CF}_{\text{SSP}}$  = Summer System Peak Coincidence Factor for Central A/C (during system peak hour)  
= 91.3%<sup>974</sup>

$\text{CF}_{\text{PJM}}$  = PJM Summer Peak Coincidence Factor for Central A/C (average during peak period)  
= 47.8%<sup>975</sup>

#### New Construction or Time of Sale:

**For example**, a 10 ton closed loop unit with Full Load EER rating of 20:

$$\begin{aligned}\Delta kW_{\text{SSP}} &= (120,000 * (1/11 - 1/20))/1000 * 0.913 \\ &= 4.482\text{kW}\end{aligned}$$

$$\begin{aligned}\Delta kW_{\text{PJM}} &= (36,000 * (1/11 - 1/20))/1000 * 0.478 \\ &= 2.347\text{kW}\end{aligned}$$

#### Early Replacement:

**For example**, a 10 ton closed loop unit with Full Load 20 EER replaces an existing working Air Source Heat Pump with 8.2 EER:

$$\begin{aligned}\Delta kW_{\text{SSP}} \text{ for remaining life of existing unit (1st 8 years):} \\ &= (120,000 * (1/8.2 - 1/20))/1000 * 0.913 \\ &= 7.883 \text{ kW}\end{aligned}$$

$$\begin{aligned}\Delta kW_{\text{SSP}} \text{ for remaining measure life (next 17 years):} \\ &= (120,000 * (1/11 - 1/20))/1000 * 0.913 \\ &= 4.482\text{kW}\end{aligned}$$

$$\begin{aligned}\Delta kW_{\text{PJM}} \text{ for remaining life of existing unit (1st 8 years):} \\ &= (120,000 * (1/8.2 - 1/20))/1000 * 0.478 \\ &= 4.127 \text{ kW}\end{aligned}$$

$$\begin{aligned}\Delta kW_{\text{PJM}} \text{ for remaining measure life (next 17 years):} \\ &= (120,000 * (1/11 - 1/20))/1000 * 0.478 \\ &= 2.347\text{kW}\end{aligned}$$

### FOSSIL FUEL SAVINGS

Calculation provided together with Electric Energy Savings above.

<sup>974</sup> Based on analysis of Itron eShape data for Missouri, calibrated to Illinois loads, supplied by Ameren. The AC load during the utility's peak hour is divided by the maximum AC load during the year.

<sup>975</sup> Based on analysis of Itron eShape data for Missouri, calibrated to Illinois loads, supplied by Ameren. The average AC load over the PJM peak period (1-5pm, M-F, June through August) is divided by the maximum AC load during the year.

### WATER AND OTHER NON-ENERGY IMPACT DESCRIPTIONS AND CALCULATION

N/A

### DEEMED O&M COST ADJUSTMENT CALCULATION

N/A

### COST EFFECTIVENESS SCREENING AND LOAD REDUCTION FORECASTING WHEN FUEL SWITCHING

This measure can involve fuel switching from gas to electric.

For the purposes of forecasting load reductions due to fuel switch GSHP projects; changes in site energy use at the customer’s meter (using  $\Delta kWh$  algorithm below), customer switching estimates, NTG, and any other adjustment factors deemed appropriate, should be used.

The inputs to cost effectiveness screening should reflect the actual impacts on the electric and fuel consumption at the customer meter and, for fuel switching measures, should therefore reflect the decrease in one fuel and increase in another, as opposed to the single savings value calculated in the “Electric and Fossil Fuel Energy Savings” section above. Therefore in addition to the calculation of savings claimed, the following values should be used to assess the cost effectiveness of the measure. For Early Replacement measures, the efficiency terms of the existing unit should be used for the remaining useful life of the existing equipment (6 years for ASHP and Central AC, 7 years for furnace, 8 years for boilers or GSHP, 15 years for electric resistance), and the efficiency terms for a new baseline unit should be used for the remaining years of the measure.

$$\begin{aligned} \Delta \text{Therms} &= [\text{Heating Consumption Replaced}] + [\text{DHW Savings if existing natural gas DHW}] \\ &= [(\text{HeatLoad} * 1 \text{ AFUE}_{\text{base}}) / 100,000] + [(1 - \text{ElecDHW}) * \% \text{DHW} * (1 / \text{EF}_{\text{GasBase}} * \\ &\quad \text{HotWaterUse}_{\text{Gallon}} * \gamma_{\text{Water}} * (T_{\text{OUT}} - T_{\text{IN}}) * 1.0) / 100,000] \\ \Delta \text{kWh} &= [\text{FurnaceFanSavings}] - [\text{GSHP heating consumption}] + [\text{Cooling savings}] + [\text{DHW savings} \\ &\quad \text{if existing electric DHW}] \\ &= [\text{FurnaceFlag} * \text{HeatLoad} * 1 / \text{AFUE}_{\text{base}} * F_e * 0.000293] - [(\text{HeatLoad} * (1 / \text{COP}_{\text{GSHP}} * \\ &\quad 3.412)) / 1000] + [(\text{EFLH}_{\text{cool}} * \text{Capacity}_{\text{Cool}} * (1 / \text{EER}_{2\text{base}} - 1 / \text{EER}_{2\text{GSHP}})) / 1000] + [\text{ElecDHW} * \\ &\quad \% \text{DHW} * ((1 / \text{EF}_{\text{ELEC}} * \text{HotWaterUse}_{\text{Gallon}} * \gamma_{\text{Water}} * (T_{\text{OUT}} - T_{\text{IN}}) * 1.0) / 3412)] \end{aligned}$$

**Illustrative Example of Cost Effectiveness Inputs for Fuel Switching:**

**For example**, a 10 ton unit with Part Load EER rating of 20 and Part Load COP of 4.4 in an Assisted living building in Chicago with a 100 gallon gas water heater replaces an existing working natural gas boiler with 75% efficiency and air-cooled chiller of 9.5 EER. [Note the calculation provides the annual savings for the first 8 years of the measure life, an additional calculation (not shown) would be required to calculate the annual savings for the remaining life (years 9-25)]:

$$\begin{aligned} \Delta \text{Therms} &= [\text{HeatLoad} * 1 \text{ AFUE}_{\text{base}}] / 100,000 + [(1 - \text{ElecDHW}) * \% \text{DHW} * (1 / \text{EF}_{\text{GasBase}} * \\ &\quad \text{HotWaterUse}_{\text{Gallon}} * \gamma \text{Water} * (T_{\text{OUT}} - T_{\text{IN}}) * 1.0) / 100,000] \\ &= [(120,000 * 1,646 * 1/0.75) / 100,000] + [(1 - 0) * 0.44 * (1/0.8 * (100 * 672) * 8.33 * (125 - \\ &\quad 50.7) * 1) / 100,000] \\ &= 2,634 + 229 \\ &= 2,863 \text{ therms} \\ \Delta \text{kWh} &= [\text{FurnaceFlag} * \text{HeatLoad} * 1 / \text{AFUE}_{\text{base}} * F_e * 0.000293] - [(\text{HeatLoad} * (1 / \text{COP}_{\text{GSHP}} * \\ &\quad 3.412)) / 1000] + [(\text{EFLH}_{\text{cool}} * \text{Capacity}_{\text{Cool}} * (1 / \text{EER}_{\text{base}} - 1 / \text{EER}_{\text{GSHP}})) / 1000] + [\text{ElecDHW} * \% \text{DHW} \\ &\quad * ((1 / \text{EF}_{\text{ELEC}} * \text{HotWaterUse}_{\text{Gallon}} * \gamma \text{Water} * (T_{\text{OUT}} - T_{\text{IN}}) * 1.0) / 3412)] \\ &= 0 - [(1646 * 120000 * (1 / 4.4 * 3.412)) / 1000] + [(1457 * 120000 * (1 / 11 - 1 / 20)) / 1000] + [0 \\ &\quad * (0.44 * ((1 / 0.9568) * (100 * 672) * 8.33 * (125 - 50.7) * 1 / 3412))] \\ &= 0 - 153,168 + 7153 + 0 \\ &= -146,015 \text{ kWh} \end{aligned}$$

**MEASURE CODE: CI-HVC-GSHP-V08-240101**

**REVIEW DEADLINE: 1/1/2025**

## 4.4.45 Adsorbent Air Cleaning

### DESCRIPTION

The Adsorbent Air Cleaning (AAC) measure installs modular adsorbent air cleaning devices (“AAC modules”) into commercial forced air HVAC systems. These devices pass return air through adsorbent media which remove the gas-phase contaminants carbon dioxide and species of volatile organic compounds (VOCs) from the return air, allowing it to be recirculated rather than removed from the building as exhaust and replaced with ventilation air. This allows HVAC system operators to substantially reduce the amount of outside air brought in for ventilation while still maintaining acceptable indoor air quality, resulting in heating and cooling energy savings. An energy penalty is incurred due to the operation of fans integrated within the AAC modules, as well as from integrated electric heaters used in a regeneration cycle which purges the adsorbent media of contaminants to allow them to be used again. Net energy savings are calculated and are equal to the cooling and heating energy savings due to reduced outdoor air minus the energy required to operate the AAC modules.

This measure serves the market for medium to large commercial and institutional buildings.

This measure is currently applicable to the following program types: NC, RF, DI. If applied to other program types, the measure savings should be verified.

### DEFINITION OF EFFICIENT EQUIPMENT

Efficient equipment is defined as a commercial HVAC system which has AAC modules installed in the return airstream, with the number of modules determined by appropriate sizing calculations. The modules allow for a substantial reduction in the volume of outside air introduced to the building compared to systems without AAC modules.

### DEFINITION OF BASELINE EQUIPMENT

Baseline equipment is a variable air volume HVAC system equipped with an integrated economizer and which does not have AAC modules installed. Heating is provided by either electricity, natural gas, or heat pump.

### DEEMED LIFETIME OF EFFICIENT EQUIPMENT

The expected measure life for HVAC applications is 20 years.<sup>976</sup>

### DEEMED MEASURE COST

Actual measure costs should be used if available. If costs are not available, the deemed measure cost below can be used, which is based on a cost per cfm of supply air flow rate.<sup>977</sup>

Unit	Material Cost / Unit (\$/cfm)	Labor Cost / Unit (\$/cfm)	Total Cost / Unit (\$/cfm)
Supply Air CFM	\$0.90	\$0.48	\$1.38

For example, the default deemed measure cost of installing the AAC measure in an HVAC system with a design supply air flow rate of 75,000 cfm is:

$$\text{Deemed Measure Cost (\$)} = 75,000 \text{ cfm} * \$1.38/\text{cfm} = \$103,500$$

### LOADSHAPE

For buildings with gas heat:

<sup>976</sup> Expected lifetime based on median years of axial fans and dampers from the ASHRAE Equipment Life Expectancy Chart.

<sup>977</sup> Default measure cost is based on sales information and labor cost estimates provided by a major Original Equipment Manufacturer (OEM) of AAC units. The OEM's estimates are based on prior installation experiences and case studies.



Loadshape C03 – Commercial Cooling

For buildings with electric heat:

Loadshape C05 – Commercial Electric Heating and Cooling

**COINCIDENCE FACTOR**

The coincidence factor is assumed to be the PJM Summer Peak Coincidence Factor for Commercial Cooling:

$$CF_{PJM} = 47.8\%^{978}$$

---

**Algorithm**

---

**CALCULATION OF ENERGY SAVINGS**

Savings associated with the Adsorbent Air Cleaning measure were derived from the results of a pilot study conducted in a commercial office building in Chicago during the 2019-2020 cooling and heating seasons. The building had a VAV system with economizer and electric heat. During the study, outdoor air rates were reduced according to the AAC module manufacturer’s recommendations. Building cooling and heating loads associated with preconditioning outdoor air were continuously measured both with baseline and reduced outdoor air flow rates over a range of outdoor air temperatures and humidities. Statistical models were developed to predict energy and peak electric load savings as a function of outdoor air flow rate and outdoor air conditions. The models were then used to simulate energy use and peak load savings in other Illinois climate zones using TMY data.

In addition to monitoring cooling and heating energy, the pilot study also measured the electricity used to operate the AAC modules for the duration of the cooling and heating seasons. This energy penalty was subtracted from the cooling and heating load savings to calculate net savings.

**ELECTRIC ENERGY SAVINGS**

Identify the building’s heating fuel. Electric energy savings will differ for buildings with natural gas, electric resistance, or electric heat pumps as a heating fuel.

For buildings with **natural gas** as a heating fuel, electric energy savings are:

$$\Delta kWh = \Delta V_{OA} * (NCLS / Cooling_{COP} - Annual Electric_{AAC})$$

For buildings with **electric resistance** as a heating fuel, electric energy savings are:

$$\Delta kWh = \Delta V_{OA} * (NCLS / Cooling_{COP} + NHLS - Annual Electric_{AAC})$$

For buildings with **electric heat pumps** as a heating fuel, electric energy savings are:

$$\Delta kWh = \Delta V_{OA} * (NCLS / Cooling_{COP} + NHLS / Heating_{COP} - Annual Electric_{AAC})$$

Where:

$\Delta V_{OA}$  = reduction in minimum outside air flow in scfm due to incorporating an AAC module

= if the rate is unknown, calculate using the following equation:

$$\Delta V_{OA} = V_{supply} * F_{OA} * F_R, \text{ where:}$$

---

<sup>978</sup> Based on analysis of Itron eShape data for Missouri, calibrated to Illinois loads, supplied by Ameren. The average AC load over the PJM peak period (1-5pm, M-F, June through August) is divided by the maximum AC load during the year.

- $V_{supply}$  = design or operational peak supply air flow rate of air handler in scfm
- $F_{OA}$  = operational minimum fraction of outside air in supply airflow before installing AAC modules
- $F_R$  = percentage reduction of outside air due to AAC modules  
= custom; if unknown, use 0.7 as a default<sup>979</sup>

**NCLS (Normalized Cooling Load Savings)**

=  $\Delta kWh/\Delta scfm$  savings value for the appropriate climate zone in the table below:

Normalized Cooling Load Savings (kWh/cfm)				
Rockford – Zone 1	Chicago – Zone 2	Springfield – Zone 3	Mt. Vernon/Belleville – Zone 4	Marion – Zone 5
17.9	18.6	24.2	26.5	23.6

**NHLS (Normalized Heating Load Savings)**

=  $\Delta kWh/\Delta scfm$  savings value for the appropriate climate zone and  $F_{OA}$  in the table below:

$F_{OA}$	Normalized Heating Load Savings (kWh/cfm)				
	Rockford – Zone 1	Chicago – Zone 2	Springfield – Zone 3	Mt. Vernon/Belleville – Zone 4	Marion – Zone 5
0.10	2.24	1.13	1.09	0.76	0.95
0.15	3.32	1.94	2.14	1.72	1.81
0.20	3.90	2.44	2.76	2.28	2.37
0.25	4.31	2.80	3.09	2.53	2.68
0.30	4.54	3.05	3.25	2.68	2.85

$Cooling_{COP}$  = seasonal average COP of building cooling plant. If unknown, use 4.0 as a default<sup>980</sup>

$Heating_{COP}$  = seasonal average COP of heat pump. If unknown, use 2.5 as a default<sup>981</sup>

$Annual\ Electric_{AAC}$  = annual electricity consumed by AAC modules for the appropriate climate zone

AAC Electricity Consumption (kWh/cfm)				
Rockford – Zone 1	Chicago – Zone 2	Springfield – Zone 3	Mt. Vernon/Belleville – Zone 4	Marion – Zone 5
1.07	0.91	1.06	0.98	0.89

<sup>979</sup> The default value of 0.7 for  $F_R$  is based on a survey of previous case studies which documented the field installation of AAC modules in existing HVAC systems.

<sup>980</sup> The default cooling COP value of 4.0 is an approximation consistent with cooling analysis in the LEED rating system, and approximates a modern, moderate efficiency water-cooled chiller (COP = 6.0) with cooling tower and pump energy usage.

<sup>981</sup> The default heating COP value of 2.5 is an approximation representing an air-source heat pump of moderate efficiency.

**For example**, office building in Climate Zone 3 is equipped with a VAV system with electric heat and has a cooling plant COP of 4.0, a design supply air flow rate of 50,000 scfm and an outdoor air ventilation rate of 10,000 scfm. Installing AAC modules will allow reduction of the outdoor air ventilation rate by 70%. In this case:

$$V_{\text{supply}} = 50,000 \text{ scfm}$$

$$F_{\text{OA}} = 10,000 \text{ scfm} / 50,000 \text{ scfm} = 0.2$$

$$F_{\text{R}} = 0.7$$

$$\Delta V_{\text{OA}} = V_{\text{supply}} * F_{\text{OA}} * F_{\text{R}} = 50,000 \text{ scfm} * 0.2 * 0.7 = 7,000 \text{ scfm}$$

$$\text{Normalized Cooling Load Savings} = 24.2 \text{ kWh/scfm (Climate zone 3, } F_{\text{OA}} = 0.2)$$

$$\text{Cooling}_{\text{COP}} = 4.0$$

$$\text{Normalized Heating Load Savings} = 2.76 \text{ kWh/scfm (Climate zone 3, } F_{\text{OA}} = 0.2)$$

$$\text{Annual Electric}_{\text{AAC}} = 1.06 \text{ kWh/scfm (Climate zone 3)}$$

$$\begin{aligned} \Delta \text{kWh} &= \Delta V_{\text{OA}} * (\text{NCLS} / \text{Cooling}_{\text{COP}} + \text{NHLS} - \text{Annual Electric}_{\text{AAC}}) \\ &= 7,000 \text{ scfm} * (24.2 \text{ kWh/scfm} / 4.0 + 2.76 \text{ kWh/scfm} - 1.06 \text{ kWh/scfm}) \\ &= 54,250 \text{ kWh} \end{aligned}$$

**SUMMER COINCIDENT PEAK DEMAND SAVINGS**

$$\Delta \text{kW} = \Delta V_{\text{OA}} * (\text{Normalized Peak Cooling Load Savings} / \text{Cooling}_{\text{COP}}) * \text{CF}_{\text{PJM}}$$

Where:

$$\text{CF}_{\text{PJM}} = 0.478$$

Normalized Peak Cooling Load Savings

= ΔkW/Δscfm savings value for the appropriate combination of building type, climate zone, and measure scenario, as detailed in the table below

Normalized Peak Cooling Load Savings (kW/cfm)				
Rockford – Zone 1	Chicago – Zone 2	Springfield – Zone 3	Mt. Vernon/Belleville – Zone 4	Marion – Zone 5
0.0259	0.0256	0.0296	0.0293	0.0283

**FOSSIL FUEL SAVINGS**

Natural gas savings do not apply to buildings where electricity is the heating fuel. For buildings where natural gas is the heating fuel:

$$\Delta \text{therms} = \Delta V_{\text{OA}} * (\text{NHLS} / \eta) * 0.03412$$

Where:

$$\eta = \text{efficiency of gas heating equipment. If unknown, use 0.78 as default.}$$

$$0.03412 = \text{therms per kWh. Conversion factor to convert kWh to therms}$$

**MEASURE CODE: CI-HVC-ADAC-V04-240101**

**REVIEW DEADLINE: 1/1/2027**

## 4.4.46 Server Room Temperature Set back

### DESCRIPTION

This measure involves adjusting existing thermostats or building automation systems for reduced cooling energy consumption and fan energy consumption in server room and/or data center spaces. Existing set points should be documented through an audit or retro-commissioning study. A maximum temperature adjustment of 95°F will limit significant increase in server fan power consumption.

This measure was developed to be applicable to the following program types: RF, DI

If applied to other program types, the measure savings should be verified.

### DEFINITION OF EFFICIENT EQUIPMENT

The criteria for this measure is established by optimizing the cooling temperature setpoint with a commercial thermostat or building automation system, up to a maximum of 95°F, which is adjusted to meet or approach ASHRAE recommended standards for data center cooling.

### DEFINITION OF BASELINE EQUIPMENT

The baseline for this measure is a commercial thermostat or building automation system that is currently controlling to cooling temperature setpoints that do not align with ASHRAE TC 9.9.

### DEEMED LIFETIME OF EFFICIENT EQUIPMENT

The expected measure life of a programmable thermostat is assumed to be 8 years.<sup>982</sup> For the purposes of claiming savings for an adjustment of an existing thermostat, this is reduced to a 50% persistence factor to give a final measure life of 4 years. It is recommended that this assumption be evaluated by future energy measurement and verification activities.

### DEEMED MEASURE COST

Actual labor costs should be used if the implementation method allows. If unknown the labor cost for this measure is assumed to be \$35.24 per thermostat,<sup>983</sup> as summarized in the following table.

Measure	Units	Materials	Labor	Total Cost (including O&P)	City Cost Index (Install Only)*	Total	Source
Adjust Temperature Set Points	4	\$0.00	\$5.95	\$6.55	134.5%	\$35.24	RS Means 2010 (pg 255, Section 23-09-8100)
* Chicago, IL – Division 23							

### LOADSHAPE

Loadshape C03 – Commercial Cooling

### COINCIDENCE FACTOR

Since the server room is cooled 8760 hours, the summer peak coincidence factor is assumed to be 100%.

<sup>982</sup> 8 years is based upon ASHRAE Applications (2003), Section 36, Table 3 estimate of 16 years for the equipment life, reduced by 50% to account for persistence issues.

<sup>983</sup> RSMMeans, "Instrumentation and Control for HVAC", Mechanical Cost Data, Kingston, MA: Reed Construction Data, 2010, pg. 255 & 632.

---

---

**Algorithm**

---

**CALCULATION OF ENERGY SAVINGS**

**ELECTRIC ENERGY SAVINGS**

$$\Delta kWh = \text{Capacity} * (1/\text{EER}) * \text{EFLH} * \text{LF} * \% \text{Savings} * (T_{\text{after}} - T_{\text{before}})$$

Where:

- Capacity = Capacity of the cooling equipment actually installed in kBtu per hour (1 ton of cooling capacity equals 12 kBtu/hr)  
= Actual
- EER = Energy efficiency ratio of the equipment  
= Actual
- EFLH = Equivalent full load hours for cooling  
= 8,760
- LF = Load Factor,  
= 65%<sup>984</sup>
- %Savings = Deemed percent savings  
= 4% per degree increase<sup>985</sup>
- T<sub>after</sub> = Space temperature setpoint after adjustment, maximum of 95°F  
= Actual
- T<sub>before</sub> = Space temperature setpoint before adjustment  
= Actual

**SUMMER COINCIDENT PEAK DEMAND SAVINGS**

$$\Delta kW = \text{Capacity} * (1/\text{EER}) * \text{LF} * \% \text{Savings} * (T_{\text{after}} - T_{\text{before}}) * \text{CF}$$

Where:

- CF = Summer Peak Coincidence Factor for measure  
= 1.0

**FOSSIL FUEL SAVINGS**

N/A

**WATER AND OTHER NON-ENERGY IMPACT DESCRIPTIONS AND CALCULATION**

N/A

---

<sup>984</sup>ASHRAE Technical Support Document, 4.2.3.2 “Estimate the Average Computer Server Heat Load”, page 4-15.

<sup>985</sup>J. Brandon. “Going Green In The Data Center: Practical Steps For Your SME To Become More Environmentally Friendly. Processor”, 29, Sept. 2007.

**DEEMED O&M COST ADJUSTMENT CALCULATION**

N/A

**MEASURE CODE: CI-HVC-SRSB-V01-200101**

**REVIEW DEADLINE: 1/1/2024**

4.4.47 Air Deflectors for Unit Ventilators – PROVISIONAL MEASURE –REMOVED IN V12.



## 4.4.48 Small Commercial Thermostats

### DESCRIPTION

This measure characterizes the energy savings from the installation of either a Programmable or an advanced Thermostat to reduce heating and cooling consumption in a small commercial building.

The thermostat must be installed to control a single-zone HVAC system. This measure is limited to packaged HVAC units 10 tons or less. This measure should not be used when HVAC systems are being replaced, in new construction and whenever code compliance is required.

The savings associated with small commercial installations of thermostats had not been well evaluated at the time this measure was created for TRM Version 8.0. In the absence of assumptions specific to small commercial customers, the percent savings derived from Illinois Residential evaluations were used. In version 9.0 the cooling savings percentage was updated based on research conducted on small commercial programmable thermostat applications.<sup>986</sup> In CY2020, additional research was performed to support a potential update to the heating savings percentage. The results did not provide a sufficient statistically significant basis for changing the current assumption.

Note that while these devices and service could potentially be used as part of a demand response program, the costs, delivery, impacts, and other aspects of DR-specific program delivery are not included in this characterization at this time, though they could be added in the future.

This measure was developed to be applicable to the following program types: TOS, RF, DI.

If applied to other program types, the measure savings should be verified.

### DEFINITION OF EFFICIENT EQUIPMENT

The criteria for this measure are established by replacement of a manual-only thermostat, with one that has the capability to establish a schedule of time and/or temperature setpoints, or replacement of a programmable thermostat with an Advanced Thermostat.

### DEFINITION OF BASELINE EQUIPMENT

The baseline is assumed to be a manual or programmable thermostat.

### DEEMED LIFETIME OF EFFICIENT EQUIPMENT

The expected measure life is assumed to be 11 years.<sup>987</sup>

### DEEMED MEASURE COST

For DI and other programs for which installation services are provided, the actual material, labor, and other costs should be used. If unknown then the average incremental cost for the new installation measure is assumed to be \$175.

### LOADSHAPE

Loadshape C05 – Commercial Electric Heating and Cooling, or

Loadshape C03 – Commercial Cooling

---

<sup>986</sup> See “Small Commercial Thermostats Research,” memorandum from Guidehouse to ComEd dated May 15, 2020.

<sup>987</sup> Based on 2017 Residential Smart Thermostat Workpaper, prepared by SCE and Nest for SCE (Work Paper SCE17HC054, Revision #0). Estimate ability of smart systems to continue providing savings after disconnection and conduct statistical survival analysis which yields 9.2-13.8 year range.

**COINCIDENCE FACTOR**

In the absence of conclusive results from empirical studies on peak savings, the TAC agreed to a temporary assumption of 50% of the cooling coincidence factor, acknowledging that while the savings from the Thermostat will track with the cooling load, the impact during peak periods may be lower. This is an assumption that could use future evaluation to improve these estimates.

$$CF_{SSP} = \text{Summer System Peak Coincidence Factor for Commercial cooling (during system peak hour)}$$

$$= 45.7^{988}$$

$$CF_{PJM} = \text{PJM Summer Peak Coincidence Factor for Commercial cooling (average during peak period)}$$

$$= 23.9\%^{989}$$

---

**Algorithm**

---

**CALCULATION OF ENERGY SAVINGS**

**ELECTRIC ENERGY SAVINGS**

Heating savings are provided based upon the percentage savings from the Residential version of this measure. Cooling savings are based on research on small commercial programmable thermostat installations. Future research on heating savings percentages for small commercial applications, and heating and cooling savings percentages for Advanced Thermostat applications, should be used to improve this assumption.

$$\Delta kWh^{990} = \Delta kWh_{heating} + \Delta kWh_{cooling}$$

$$\Delta kWh_{heating} = (\%ElecHeat * kBtu/hr_{heat} * 1/HSPF2 * EFLH_{heat} * Heating\_Reduction * BAF) + (\Delta Therms * F_e * 29.3)$$

$$\Delta kWh_{cool} = kBtu/hr_{cool} * 1/SEER2 * EFLH_{cool} * Cooling\_Reduction * BAF$$

Where:

- $\%ElecHeat$  = Percentage of heating savings assumed to be electric  
= 1 if electric heat, 0 if gas heat. If unknown assume 0.08<sup>991</sup>.
- $kBtu/hr_{heat}$  = capacity of the heating equipment in kBtu per hour.  
= Actual. If unknown assume 114.5<sup>992</sup>
- $HSPF2$  = Heating Seasonal Performance Factor of the equipment  
= Actual, if unknown a blended baseline value of 5.1 HSPF2<sup>993</sup>.
- $EFLH_{heat}$  = Heating mode equivalent full load hours in Existing Buildings are provided in section 4.4 HVAC End Use.

<sup>988</sup> Based on analysis of Itron eShape data for Missouri, calibrated to Illinois loads, supplied by Ameren. The AC load during the utility’s peak hour is divided by the maximum AC load during the year. Multiplied by 50%.

<sup>989</sup> Based on analysis of Itron eShape data for Missouri, calibrated to Illinois loads, supplied by Ameren. The average AC load over the PJM peak period (1-5pm, M-F, June through August) is divided by the maximum AC load during the year. Multiplied by 50%.

<sup>990</sup> Electrical savings are a function of both heating and cooling energy usage reductions. For heating this is a function of the percent of electric heat (heat pumps) and fan savings in the case of a natural gas furnace.

<sup>991</sup> Based on percentage of customers in ComEd Small Business Thermostat program with electric heat.

<sup>992</sup> Average capacity of 705 installs of thermostats in Ameren Illinois territory installed from 2015-2020.

<sup>993</sup> Blended Baseline value came from percentage of accounts with heat pumps (40.17%) at 7.5 HSPF2 and electric furnaces (59.83%) at 3.41 HSPF as reported in the ComEd Baseline Study August 14, 2020.

Heating_Reduction	= Assumed percentage reduction in total building heating energy consumption due to thermostat = 8.8% <sup>994</sup>
ΔTherms	= Therm savings if Natural Gas heating system = See calculation in Fossil Fuel section below
F <sub>e</sub>	= Furnace Fan energy consumption as a percentage of annual fuel consumption = 7.7% <sup>995</sup>
29.3	= kWh per therm
kBtu/hr <sub>cool</sub>	= capacity of the cooling equipment actually installed in kBtu per hour (1 ton of cooling capacity equals 12 kBtu/hr) = Actual. If unknown assume 61.0 <sup>996</sup>
SEER2	= Seasonal Energy Efficiency Ratio of the cooling equipment = Actual, is unknown assume Code base. For midstream programs, assume a value of 12.4 SEER2. <sup>997</sup>
EFLH <sub>cool</sub>	= Equivalent Full Load Hours for cooling in Existing Buildings are provided in section 4.4 HVAC End Use.
Cooling_Reduction	= Average percentage reduction in total building cooling energy consumption due to installation of thermostat: = 17.7% <sup>998</sup>

<sup>994</sup> Assumed equal to assumption for Residential Advanced Thermostats with manual thermostat baseline, before adding savings from Thermostat Optimization (which is not applicable to small commercial customers). Note that a Guidehouse billing study in CY2020 did not find a statistically significant basis for adjusting this assumption for commercial applications, see "Small Commercial Thermostats TRM Research" memo. April 21, 2021.

Estimates of heating and cooling reduction factors are based on consumption data analyses with matching to non-participants and are therefore net with respect to participant spillover and between net and gross with respect to free ridership. Like all consumption data analyses, they are gross with respect to non-participant spillover. For more detail, see Table 5-3 in Volume 4 of the IL-TRM. Consistent with Section 7.2 of the Illinois EE Policy Manual, applicable net-to-gross adjustments to these factors will be determined as part of the annual SAG net-to-gross process.

<sup>995</sup> F<sub>e</sub> is estimated using TRM models for the three most popular building types for programmable thermostats: low-rise office (10.2%), sit-down restaurant (8.6%), and retail – strip mall (4.4%). 7.7% reflects the average F<sub>e</sub> of the three building types. See "Fan Energy Factor Example Calculation 2021-06-23.xlsx" for reference.

<sup>996</sup> Average capacity of 639 installs of thermostats on units <=10tons in Ameren Illinois territory installed from 2015-2020 and 706 installs on units <=10tons in ComEd territory in 2021.

<sup>997</sup> Calculated as the blend of heat pump and other central air conditioning (CAC) equipment in the East North Central census region as found in the 2012 Commercial Building Energy Consumption Survey (CBECS), where 4.5% of buildings with cooling systems able to be controlled by a smart thermostat utilize a heat pump with an assumed code baseline SEER of 13 (SEER2 12.4). This assumes a system capacity less than 65 kbtu/h. The remaining 94% of cooling systems are assumed to be split-system and single package CAC systems (<65 kbtu/h) with varying code SEER baselines. The 13.47 SEER / 12.8 SEER2 is the weighted average of cooling systems.

<sup>998</sup> Based on research conducted by Guidehouse on a sample of IL Small Commercial programmable thermostat installations, which found a range of savings values depending on the modeling assumptions used. Guidehouse recommended selecting the midpoint of this range, which it deemed preferable to continuing to rely on Residential assumptions, while also accounting for the relative uncertainties involved. See "Small Commercial Thermostats Research" memo completed in 2020.

Estimates of heating and cooling reduction factors are based on consumption data analyses with matching to non-participants and are therefore net with respect to participant spillover and between net and gross with respect to free ridership. Like all consumption data analyses, they are gross with respect to non-participant spillover. For more detail, see Table 5-3 in Volume 4 of the IL-TRM. Consistent with Section 7.2 of the Illinois EE Policy Manual, applicable net-to-gross adjustments to these factors will be determined as part of the annual SAG net-to-gross process.

BAF = Baseline adjustment factor.  
 = 1.0, if the baseline thermostat was manual type  
 = 0.6, if the baseline thermostat was programmable type<sup>999</sup>  
 = 0.8, if the baseline is unknown<sup>1000</sup>

**SUMMER COINCIDENT PEAK DEMAND SAVINGS**

$$\Delta KW = \text{kBtu/hr}_{\text{cool}} * 1/\text{EER2} * \text{Cooling\_Reduction} * \text{BAF} * \text{CF}$$

Where:

EER2 = Energy Efficiency Ratio of the equipment  
 = Actual, if unknown assume current Code. For midstream programs, assume a value of 10.9 EER2.<sup>1001</sup> For air-cooled units < 65 kBtu/hr, assume the following conversion from SEER to EER for calculation of peak savings:<sup>1002</sup>

$$\text{EER} = (-0.02 * \text{SEER}^2) + (1.12 * \text{SEER})$$

CF<sub>SSP</sub> = Summer System Peak Coincidence Factor for Commercial cooling (during system peak hour)  
 = 45.7<sup>1003</sup>

CF<sub>PJM</sub> = PJM Summer Peak Coincidence Factor for Commercial cooling (average during peak period)  
 = 23.9%<sup>1004</sup>

Other variables as provided above.

**FOSSIL FUEL SAVINGS**

$$\Delta \text{Therms} = ((1 - \% \text{ElectricHeat}) * \text{EFLH}_{\text{heat}} * \text{Capacity} * 1/\text{AFUE} * \text{Heating\_Reduction} * \text{BAF}) / 100,000 \text{Btu/Therm}$$

Where:

Capacity = Nominal Heating Input Capacity (Btu/hr) of heating system

<sup>999</sup> This factor represents the ratio of thermostat adjustment savings to thermostat replacement savings. It is based on actual thermostat algorithm data (i.e., degrees of setback, hours values, fan modes) from two years of ComEd AirCare Plus Program data (PY9+ and CY2018), including 382 thermostat adjustment installations and 3,847 thermostat replacement installations. An analysis of the data showed that on average, thermostat adjustments saved 61% and 59% of the thermostat replacement cooling savings and heating savings, respectively. For simplicity, a value of 0.6 was selected for both cooling and heating savings adjustment. See IL TRM Workpaper “4.4.48 Small Commercial Thermostats”, Guidehouse, 6/23/2021 for details.

<sup>1000</sup> Review of ComEd’s 2020 Baseline Study and 2019-2020 Program Data indicates that approximately half of installs are in buildings with existing manual thermostats, and half with existing programmable thermostats.

<sup>1001</sup> Calculated using the SEER to EER formula and assumed SEER of 13.47, converted to EER2.

<sup>1002</sup> Based on Wassmer, M. (2003). A Component-Based Model for Residential Air Conditioner and Heat Pump Energy Calculations. Masters Thesis, University of Colorado at Boulder. Note this is appropriate for single speed units only.

<sup>1003</sup> Based on analysis of Itron eShape data for Missouri, calibrated to Illinois loads, supplied by Ameren. The AC load during the utility’s peak hour is divided by the maximum AC load during the year. Multiplied by 50%.

<sup>1004</sup> Based on analysis of Itron eShape data for Missouri, calibrated to Illinois loads, supplied by Ameren. The average AC load over the PJM peak period (1-5pm, M-F, June through August) is divided by the maximum AC load during the year. Multiplied by 50%.

= Actual  
AFUE = Annual Fuel Utilization Efficiency Rating  
= Actual, if unknown assume code baseline. For midstream prorams, assume a value of 0.8.<sup>1005</sup>

Other variables as provided above.

**WATER AND OTHER NON-ENERGY IMPACT DESCRIPTIONS AND CALCULATION**

N/A

**DEEMED O&M COST ADJUSTMENT CALCULATION**

N/A

**MEASURE CODE: CI-HVC-THST-V06-240101**

**REVIEW DEADLINE: 1/1/2029**

---

<sup>1005</sup> Residential sized units (<225kbtu/h) as per Code of Federal Regulations, effective November, 2015 (10 CFR 432(e))

## 4.4.49 Boiler Chemical Descaling

### DESCRIPTION

The measure is for a non-residential hot water or steam boiler serving process loads or one that provides space heating. Even with careful and precise water treatment in a boiler system, mineral scales are formed over time due to the high pressure and heat. Boiler scale is typically calcium, carbon, iron and silica particle deposits that form on the boiler tubes. Scale creates a problem because it typically possesses a thermal conductivity, an order of magnitude less than the corresponding value for bare steel. Even thin layers of scale serve as an effective insulator and inhibit heat transfer. The result is overheating of boiler tube metal, tube failures, and loss of energy efficiency.

De-scaling a boiler system will improve boiler efficiency by removing mineral scale build up on boiler tubes. De-scaling is done either through mechanical or chemical cleaning techniques. There are several limitations to mechanical cleaning, namely firetube boilers cannot be mechanically cleaned. Depending on the size of the boiler, it can take up to a week to mechanically clean the tubes. This measure applies to chemical de-scaling, which is an efficient alternative, since it is not plagued by these limitations. The procedure typically involves the boiler being emptied and taken off-line, following which, the correct chemical solution ratio is pumped through the boiler system for four to eight hours.

This measure was developed to be applicable to the following program types: RF. If applied to other program types, the measure savings should be verified.

### DEFINITION OF EFFICIENT EQUIPMENT

To qualify for this measure, the facility must, as applicable, complete the chemical de-scaling by an approved technician and be NSF/ANSI/CAN 60 compliant.<sup>1006</sup>

The efficient equipment is a boiler system which has been de-scaled using a chemical solution. After the cleaning is complete, the personnel have to ensure that all safety checks are completed including checks for leaks. Lastly, any remains of the descaling chemical solution have to be eliminated from the tubes by flushing the system with water and a blowdown.

### DEFINITION OF BASELINE EQUIPMENT

The baseline condition is a boiler system that is compromised by scale build up.

### DEEMED LIFETIME OF EFFICIENT EQUIPMENT

The lifetime of this measure varies based on the location of the site in Illinois. It has been established that the rate of scale buildup in hydronic systems is directly dependent on the hardness of the supply water (the amount of dissolved Calcium, Magnesium and Iron).<sup>1007</sup> Based on an analysis of water supply composition in Illinois,<sup>1008</sup> the estimated life of measure(in years) before requiring de-scaling is listed below:

Climate Zone	Measure Life of De-scaling
Rockford	2
Chicago	6

<sup>1006</sup> NSF/ANSI/CAN 60 Standard: "If you manufacture, sell or distribute water treatment chemicals in North America, your products are required to comply with NSF/ANSI/CAN 60: Drinking Water Treatment Chemicals – Health Effects by most governmental agencies that regulate drinking water supplies."

<sup>1007</sup> 'Study on Benefits of Removal of Water Hardness (Calcium and Magnesium Ions) from a Water Supply', Battelle Memorial Institute, accessed April 2020.

<sup>1008</sup> The Water Quality Reports from 'Illinois American Water' were analyzed for all five TRM zones in Illinois. Based on the water hardness level and Iron content, a correlation was made to the estimated usage of hydronic equipment before de-scaling is required. See page v of 'Study on Benefits of Removal of Water Hardness (Calcium and Magnesium Ions) from a Water Supply', Battelle Memorial Institute and "Water Quality Summary.xlsx" for reference.

Climate Zone	Measure Life of De-scaling
Springfield	2
Belleville	3
Marion	3

**DEEMED MEASURE COST**

The cost of this measure is estimated to be \$378/MMBtu/hr per boiler.<sup>1009</sup>

**LOADSHAPE**

N/A

**COINCIDENCE FACTOR**

N/A

---



---

**Algorithm**

---

**CALCULATION OF ENERGY SAVINGS**

**ELECTRIC ENERGY SAVINGS**

N/A

**SUMMER COINCIDENT PEAK DEMAND SAVINGS**

N/A

**FOSSIL FUEL SAVINGS**

$$\Delta\text{Therms} = (\text{Capacity} * \text{EFLH} * \%Ei) / 100,000$$

Where:

- Capacity = Nominal Heating Input Capacity Boiler Size (Btu/hr) for boiler unit  
= Actual
- EFLH = Equivalent Full Load Hours for heating in Existing Buildings are provided in section 4.4 HVAC End Use. For process loads, use custom hours.
- %Ei = Percent efficiency improvement from chemical descaling  
= Dependent on system pressure and estimate of scale thickness. If unknown assume normal.<sup>1010</sup>

---

<sup>1009</sup> Averaged from quotes from two chemical de-scaling solution manufacturers. Quote based on one day service with two personnel, including circulating pumps, tank assembly and other necessary fittings. Quotes based on pilot project study done by Nicor Gas Emerging Technology Program and Gas Technology Institute (GTI), “Descaling of Steam Boiler Systems”, 2019-2020. A 20% RYDLYME solution is assumed for cost, based on the pilot.

<sup>1010</sup> Estimates based on pilot project study done by Nicor Gas Emerging Technology Program and Gas Technology Institute (GTI), “Descaling of Steam Boiler Systems”, 2019-2020, and review of the following studies: ‘Clean Firetube Boiler Waterside Heat Transfer Surfaces’, U.S. Department of Energy, April 2012. ‘Energy Conservation Program Guide for Industry and Commerce’, NBS Handbook 115 Supplement 1, U.S. Department of Energy, December 1975, accessed April 2020.

Scale Thickness (inches)	Efficiency Improvement (%Ei)	
	Low Pressure (15psig and below) Applications	High Pressure (above 15psig) Applications
Low ( $\leq 1/64$ )	1%	1.6%
Normal ( $\geq 1/32$ & $\leq 3/64$ )	2.5%	3.9%
High ( $\geq 1/16$ )	3.9%	6.2%

100,000 = Converts Btu to Therms

**For example**, a 10,000 MBH firetube steam boiler in a Manufacturing facility in Rockford. The scaling on the tubes was estimated to be of ‘normal’ thickness and the steam supply was ‘low pressure’ at 15 psig.

$$\begin{aligned} \Delta\text{Therms} &= (\text{Capacity} * \text{EFLH} * \%Ei) / 100,000 \\ &= (10,000,000 * 1,048 * 0.025) / 100,000 \\ &= 2,620 \text{ Therms} \end{aligned}$$

**WATER AND OTHER NON-ENERGY IMPACT DESCRIPTIONS AND CALCULATION**

N/A

**DEEMED O&M COST ADJUSTMENT CALCULATION**

N/A

**MEASURE CODE: CI-HVC-BCHD-V02-240101**

**REVIEW DEADLINE: 1/1/2029**



#### 4.4.50 Electric Chillers with Integrated Variable Speed Drives – REMOVED v12

#### 4.4.51 Advanced Rooftop Controls with High Rotor Pole Switch Reluctance Motors

##### **DESCRIPTION**

A High Rotor Pole Switch Reluctance Motor (HRSRM) is a type of brushless DC electric motor that runs by reluctance torque. Unlike other DC motor types, power is delivered to windings in the stator rather than the rotor. This simplifies the mechanical design; power does not need to be delivered to a moving part, but requires a switching system through software control to deliver power to the different windings. Electronic devices can precisely time switch, facilitating HRSRM configurations.

In applications on rooftop units (RTUs), the HRSRM motor is comparable or more efficient than an RTU equipped with a variable speed drive supply fan. It results in fan-energy savings and can also include cooling savings if coupled with compressor or ventilation control, compared to a baseline scenario of constant-volume, constant-ventilation operation that is typical of single-zone, packaged HVAC units.

Fan energy savings come from the new integrated motor controls that allow for higher efficiency at varying loads and is achieved in all applications. Cooling savings can also be added from the effective use of variable speed or multi-stage cooling.

The markets that can be served by HRSRM motors are those which utilize RTUs, including but not limited to:

- 1 Fast-Service Restaurant
- 2 Full-Service Restaurant
- 3 Small Office
- 4 Stand-Alone Retail
- 5 Strip Mall
- 6 Warehouse

This measure was developed to be applicable to the following program types: NC, RF, EREP. If applied to other program types, the measure savings should be verified.

##### **DEFINITION OF EFFICIENT EQUIPMENT**

The efficient equipment is a single-zone, packaged HVAC unit with an existing functional integrated economizer that has been fitted with a HRSRM supply-fan and integrated speed control. This applies to both retrofit and new construction, and early replacement applications.

##### **DEFINITION OF BASELINE EQUIPMENT**

The baseline equipment is a single-zone, packaged HVAC unit (with an existing functional integrated economizer) that lacks demand-controlled ventilation controls and lacks supply-fan speed control via a variable-frequency drive.

##### **DEEMED LIFETIME OF EFFICIENT EQUIPMENT**

The expected measure life is assumed to be 12 years based on the HRSRM life.<sup>1011</sup>

##### **DEEMED MEASURE COST**

Actual measure costs should be used if available. If costs are not available, the deemed measure cost below can be used. Material cost is based on the horsepower (hp) of the supply fan used in the RTU. Retrofit represents the full cost of the installation. New construction and early replacement represent the incremental cost of the motor itself on a new unit.<sup>1012</sup>

---

<sup>1011</sup> Based on life cycle of a switch reluctance motor from P. Andrada, B. Blanque, E. Martinez, J.I. Perat, J.A. Sanchez, and M. Torrent, "Environmental and life cycle cost analysis of one switched reluctance motor drive and two inverter-fed induction motor drives," IET Electric Power Applications (2010): page 8.

<sup>1012</sup> Based on cost data from Turntide on HRSRM motors, <https://turntide.com>

**Deemed Measure Cost Details**

Type	HP	Material Cost	Labor Hours	Labor Rate	Deemed Cost
Retrofit	1	\$1,554.75	3	\$96.67	\$1,844.76
Retrofit	1.5	\$1,580.75	3	\$96.67	\$1,870.76
Retrofit	2	\$1,644.75	3	\$96.67	\$1,934.76
Retrofit	5	\$1,758.75	3	\$96.67	\$2,048.76
Retrofit	7.5	\$2,417.75	3	\$96.67	\$2,707.76
Retrofit	10	\$2,587.75	3	\$96.67	\$2,877.76
New Construction/Early Replacement	1	\$932.85	-	-	\$932.85
New Construction/Early Replacement	1.5	\$948.45	-	-	\$948.45
New Construction/Early Replacement	2	\$986.85	-	-	\$986.85
New Construction/Early Replacement	5	\$1,055.25	-	-	\$1,055.25
New Construction/Early Replacement	7.5	\$1,450.65	-	-	\$1,450.65
New Construction/Early Replacement	10	\$1,552.65	-	-	\$1,552.65

**LOADSHAPE**

Commercial ventilation C23

**COINCIDENCE FACTOR**

CF<sub>SSP</sub> = Summer System Peak Coincidence Factor for Commercial cooling (during system peak hour)  
 = 91.3%<sup>1013</sup>

CF<sub>PJM</sub> = PJM Summer Peak Coincidence Factor for Commercial cooling (average during peak period)  
 = 47.8%<sup>1014</sup>

<sup>1013</sup> Based on analysis of Itron eShape data for Missouri, calibrated to Illinois loads, supplied by Ameren. The AC load during the utility’s peak hour is divided by the maximum AC load during the year.

<sup>1014</sup> Based on analysis of Itron eShape data for Missouri, calibrated to Illinois loads, supplied by Ameren. The average AC load over the PJM peak period (1-5pm, M-F, June through August) is divided by the maximum AC load during the year

**Algorithm**

**CALCULATION OF ENERGY SAVINGS**

Six different building types were selected for study. OpenStudio measures were used to generate ASHRAE 90.1-2013 code-compliant DOE prototype baseline models for each building type. The total conditioned area, the number of conditioned zones, and the peak cooling demand for each building are summarized in the following table.<sup>1015</sup>

**Selected DOE Prototype Buildings**

Building Type	Small Office	Stand-Alone Retail	Warehouse	Strip Mall	Fast-Service Restaurant	Full-Service Restaurant
Conditioned Area (ft <sup>2</sup> )	5,502	24,692	52,045	22,500	2,501	5,502
Number of Conditioned Zones	5	4	3	10	2	2
Total Fan Break Horsepower (BHP)	3.5	25	5	23	7	11
Design Cooling Load (Ton)	8.5	65	13	69	20	33

In order to achieve savings, the RTU control options consist of following modes:

1. Ventilation Mode:
  - a. Outdoor air is at a minimum for building type
  - b. Fan speed set to 40%
  - c. Heating and cooling coils are off
2. Economizer Mode
  - a. Outdoor air rate was set from 40% and increased as needed to satisfy indoor air temperature
  - b. When outdoor air could no longer satisfy cooling, cooling mode was staged on
3. Mechanical Cooling Mode
  - a. Outdoor air is at a minimum for building type
  - b. Compressors (if multiple or variable) were staged/modulated to meet setpoint temperature of the space
  - c. Supply fan set to 100%
4. Heating mode
  - a. Outdoor air is at a minimum for building type
  - b. Heating coil staged as necessary
  - c. Supply fan set to 100%

The models produced a percentage energy savings based on using a HRSRM fan and varying compressor types. Retrofit savings include fan only. For new construction and early replacement, savings are based on compressor type and energy efficiency of the unit. These RTU control options are reflected in the table below. As a correction to these entries, a second set of single two-stage compressor RTU fan options are also reflected in the *Energy Savings Type: ESF\_Fan* entry in the table below<sup>1016</sup> and are characterized by the following speed settings:

1. Ventilation Mode:
  - a. Outdoor air is at a minimum for building type
  - b. Supply fan set to 40%

<sup>1015</sup> Korbaga Woldekidan, Daniel Studer, and Ramin Faramarzi, "Performance Evaluation of Three RTU Energy Efficiency Technologies," 2019.

<sup>1016</sup> Lick, A., A. Cardiel, J. Zhou, S. Hackel, S. Pigg, and K. Gries. "Switched-Reluctance Motor Field Evaluation Final Report." Slipstream project report for the ComEd Energy Efficiency Program. March 25, 2022. <https://comedemergingtech.com/project/srm-field-evaluation..>

- c. Heating and cooling coils are off
- 2. Economizer Mode:
  - a. No change compared to existing RTU settings
- 3. Mechanical Cooling Mode (Stage 1):
  - a. Outdoor air is at a minimum for building type
  - b. Compressor stage 1 ON
  - c. Supply fan set to 75%
- 4. Mechanical Cooling Mode (Stage 2):
  - a. Outdoor air is at a minimum for building type
  - b. Compressor stage 1 & 2 ON
  - c. Supply fan set to 90%
- 5. Heating Mode:
  - a. Outdoor air is at a minimum for building type
  - b. Heating coil staged as necessary
  - c. Supply fan set to 90%

### ELECTRIC ENERGY SAVINGS

For units with cooling capacities less than 65 kBtu/hr:

$$\Delta\text{kWH} = (\text{kBtu/hr}) * (1/\text{SEER}_{\text{exist}}) * \text{EFLH} * \text{ESF}_{\text{Cooling}} + 0.746 * \text{FanHP} * \text{RunHours} * \text{ESF}_{\text{Fan}}$$

For units with cooling capacities equal to or greater than 65 kBtu/hr:

$$\Delta\text{kWH} = (\text{kBtu/hr}) * (1/\text{IEER}_{\text{exist}}) * \text{EFLH} * \text{ESF}_{\text{Cooling}} + 0.746 * \text{FanHP} * \text{RunHours} * \text{ESF}_{\text{Fan}}$$

Where:

kBtu/hr	= capacity of the cooling equipment in kBtu per hour (1 ton of cooling capacity equals 12 kBtu/hr)
SEER <sub>exist</sub>	= Seasonal Energy Efficiency Ratio of the existing equipment  = Actual. Or assume Code base in place at the original time of existing unit installation. IECC 2018 (effective July 1, 2019 to until IECC 2021 effective date) and IECC 2021 (expected to become effective statewide in 2023) provided below for referenced. As code requirements and adoption can differ from municipality to municipality, the user should verify which version of code is applicable given these constraints.
IEER <sub>exist</sub>	= Integrated Energy Efficiency Ratio of the existing equipment  = Actual. Or assume Code base in place at the original time of existing unit installation. IECC 2018 (effective July 1, 2019 to until IECC 2021 effective date) and IECC 2021 (is expected to become effective statewide in 2023) provided below for reference. As code requirements and adoption can differ from municipality to municipality, the user should verify which version of code is applicable given these constraints.
EFLH	= Equivalent Full Load Hours for cooling in Existing Buildings or New Construction are provided in Illinois TRM version 8.0 section 4.4 HVAC End Use
ESF <sub>Cooling</sub>	= Energy savings factor for cooling as found in table below. <sup>1017</sup>
ESF <sub>Fan</sub>	= Energy savings factor for cooling as found in table below <sup>1018</sup>

<sup>1017</sup> Average cooling savings for all building types from paper entitled “Performance Evaluation of Three RTU Energy Efficiency Technologies.” Savings averaged by RTU compressor type.

<sup>1018</sup> Based on forthcoming ComEd Field Study (final results TBD)

**Energy Savings Factors**

Energy Savings Type	Retrofit Type	HRSRM on Single Stage Compressor	HRSRM on Single Two Stage Compressor	HRSRM on Variable Speed Compressor
ESF_Cooling <sup>1019</sup>	New Construction/Early Replacement	0%	0%	0%
ESF_Cooling <sup>1020</sup>	Supply Fan Retrofit Only	0.0%	0.0%	0.0%
ESF_Fan <sup>1020</sup>	New Construction/Early Replacement	46.6%	61.0%	64.8%
ESF_Fan <sup>1020</sup>	Supply Fan Retrofit Only	46.6%	61.0%	64.8%

FanHP = Horsepower of fan in RTU

= Actual

RunHours = Annual operating hours for fan motor based on building type

= Default hours are provided for HVAC applications which vary by HVAC application and building type in the following table.<sup>1021</sup> When available, actual hours should be used.

Building Type	Total Fan Run Hours	Model Source
Assembly	7,235	eQuest
Assisted Living	8,760	eQuest
Auto Dealership	7,451	OpenStudio
College	4,836	OpenStudio
Convenience Store	7,004	eQuest
Drug Store	7,156	OpenStudio
Elementary School	3,765	OpenStudio
Emergency Services	8,760	OpenStudio
Garage	7,357	eQuest
Grocery	8,543	OpenStudio
Healthcare Clinic	4,314	OpenStudio
High School	3,460	OpenStudio
Manufacturing Facility	8,706	eQuest
MF – High Rise	8,760	OpenStudio
MF – Mid Rise	8,760	OpenStudio
Hotel/Motel – Guest	2,409	OpenStudio
Hotel/Motel – Common	8,683	OpenStudio
Movie Theater	7,505	eQuest
Office – Low Rise	6,345	OpenStudio
Office – Mid Rise	3,440	OpenStudio
Religious Building	7,380	eQuest
Restaurant	7,302	OpenStudio
Retail – Department Store	7,155	OpenStudio
Retail – Strip Mall	6,921	OpenStudio

<sup>1019</sup> Energy savings in this row only are due to control of the RTU that goes beyond solely fan motor replacement and utilizes additional control like ventilation or compressor control. Measures should incorporate additional control to claim savings here. See related footnotes for details.

<sup>1020</sup> The numbers in the “HRSRM on Single Two Stage Compressor” column are based on the field study “Switched-Reluctance Motor Field Evaluation Final Report.” The numbers in the other two columns are based on the field study and the simulation study “Performance Evaluation of Three RTU Energy Efficiency Technologies.”

<sup>1021</sup> Hours per year are estimated using the eQuest or OpenStudio models as the total number of hours the fans are operating for heating, cooling, and ventilation for each building type.

Building Type	Total Fan Run Hours	Model Source
Warehouse	6,832	OpenStudio
Unknown	6,241	n/a

**2018 IECC Minimum Efficiency Requirements**

TABLE C403.3.2(1)  
MINIMUM EFFICIENCY REQUIREMENTS: ELECTRICALLY OPERATED UNITARY AIR CONDITIONERS AND CONDENSING UNITS

EQUIPMENT TYPE	SIZE CATEGORY	HEATING SECTION TYPE	SUBCATEGORY OR RATING CONDITION	MINIMUM EFFICIENCY	TEST PROCEDURE <sup>a</sup>		
Air conditioners, air cooled	< 65,000 Btu/h <sup>b</sup>	All	Split System	13.0 SEER	AHRI 210/240		
			Single Package	14.0 SEER			
Through-the-wall (air cooled)	≤ 30,000 Btu/h <sup>b</sup>	All	Split system	12.0 SEER			
			Single Package	12.0 SEER			
Small-duct high-velocity (air cooled)	< 65,000 Btu/h <sup>b</sup>	All	Split System	11.0 SEER			
Air conditioners, air cooled	≥ 65,000 Btu/h and < 135,000 Btu/h	Electric Resistance (or None)	Split System and Single Package	11.2 EER 12.8 IEER		AHRI 340/360	
			All other	11.0 EER 12.6 IEER			
	≥ 135,000 Btu/h and < 240,000 Btu/h	Electric Resistance (or None)	Split System and Single Package	11.0 EER 12.4 IEER			
			All other	10.8 EER 12.2 IEER			
	≥ 240,000 Btu/h and < 760,000 Btu/h	Electric Resistance (or None)	Split System and Single Package	10.0 EER 11.6 IEER			
			All other	9.8 EER 11.4 IEER			
	≥ 760,000 Btu/h	Electric Resistance (or None)	Split System and Single Package	9.7 EER 11.2 IEER			
			All other	9.5 EER 11.0 IEER			
	Air conditioners, water cooled	< 65,000 Btu/h <sup>b</sup>	All	Split System and Single Package	12.1 EER 12.3 IEER		AHRI 210/240
				Split System and Single Package	12.1 EER 13.9 IEER		
≥ 65,000 Btu/h and < 135,000 Btu/h		Electric Resistance (or None)	Split System and Single Package	11.9 EER 13.7 IEER	AHRI 340/360		
			All other	12.5 EER 13.9 IEER			
≥ 135,000 Btu/h and < 240,000 Btu/h		Electric Resistance (or None)	Split System and Single Package	12.3 EER 13.7 IEER			
			All other	12.4 EER 13.6 IEER			
≥ 240,000 Btu/h and < 760,000 Btu/h		Electric Resistance (or None)	Split System and Single Package	12.2 EER 13.4 IEER			
			All other	12.2 EER 13.5 IEER			
≥ 760,000 Btu/h		Electric Resistance (or None)	Split System and Single Package	12.0 EER 13.3 IEER			
			All other	12.0 EER 13.3 IEER			

Illinois Statewide Technical Reference Manual – 4.4.51 Advanced Rooftop Controls with High Rotor Pole Switch Reluctance Motors

Air conditioners, evaporatively cooled	< 65,000 Btu/h <sup>b</sup>	All	Split System and Single Package	12.1 EER 12.3 IEER	AHRI 210/240
	≥ 65,000 Btu/h and < 135,000 Btu/h	Electric Resistance (or None)	Split System and Single Package	12.1 EER 12.3 IEER	AHRI 340/360
		All other	Split System and Single Package	11.9 EER 12.1 IEER	
	≥ 135,000 Btu/h and < 240,000 Btu/h	Electric Resistance (or None)	Split System and Single Package	12.0 EER 12.2 IEER	
		All other	Split System and Single Package	11.8 EER 12.0 IEER	
	≥ 240,000 Btu/h and < 760,000 Btu/h	Electric Resistance (or None)	Split System and Single Package	11.9 EER 12.1 IEER	
		All other	Split System and Single Package	11.7 EER 11.9 IEER	
	≥ 760,000 Btu/h	Electric Resistance (or None)	Split System and Single Package	11.7 EER 11.9 IEER	
All other		Split System and Single Package	11.5 EER 11.7 IEER		
Condensing units, air cooled	≥ 135,000 Btu/h	—	—	10.5 EER 11.8 IEER	AHRI 365
Condensing units, water cooled	≥ 135,000 Btu/h	—	—	13.5 EER 14.0 IEER	
Condensing units, evaporatively cooled	≥ 135,000 Btu/h	—	—	13.5 EER 14.0 IEER	

For SI: 1 British thermal unit per hour = 0.2931 W.

- a. Chapter 6 contains a complete specification of the referenced test procedure, including the reference year version of the test procedure.
- b. Single-phase, air-cooled air conditioners less than 65,000 Btu/h are regulated by NAECA. SEER values are those set by NAECA.



**2021 IECC Minimum Efficiency Requirements**

TABLE C403.3.2(1)  
ELECTRICALLY OPERATED UNITARY AIR CONDITIONERS AND CONDENSING UNITS—MINIMUM EFFICIENCY REQUIREMENTS<sup>a, d</sup>

EQUIPMENT TYPE	SIZE CATEGORY	HEADING SECTION TYPE	SUBCATEGORY OR RATING CONDITION	MINIMUM EFFICIENCY	TEST PROCEDURE <sup>a</sup>
Air conditioners, air cooled	< 65,000 Btu/h <sup>b</sup>	All	Split system, three phase and applications outside US single phase <sup>b</sup>	13.0 SEER before 1/1/2023 13.4 SEER <sub>2</sub> after 1/1/2023	AHRI 210/240—2017 before 1/1/2023
			Single-package, three phase and applications outside US single phase <sup>b</sup>	14.0 SEER before 1/1/2023 13.4 SEER <sub>2</sub> after 1/1/2023	AHRI 210/240—2023 after 1/1/2023
Space constrained, air cooled	≤ 30,000 Btu/h <sup>b</sup>	All	Split system, three phase and applications outside US single phase <sup>b</sup>	12.0 SEER before 1/1/2023 11.7 SEER <sub>2</sub> after 1/1/2023	AHRI 210/240—2017 before 1/1/2023
			Single package, three phase and applications outside US single phase <sup>b</sup>	12.0 SEER before 1/1/2023 11.7 SEER <sub>2</sub> after 1/1/2023	AHRI 210/240—2023 after 1/1/2023
Small duct, high velocity, air cooled	< 65,000 Btu/h <sup>b</sup>	All	Split system, three phase and applications outside US single phase <sup>b</sup>	12.0 SEER before 1/1/2023 12.1 SEER <sub>2</sub> after 1/1/2023	AHRI 210/240—2017 before 1/1/2023 AHRI 210/240—2023 after 1/1/2023
Air conditioners, air cooled	≥ 65,000 Btu/h and < 135,000 Btu/h	Electric resistance (or none)	Split system and single package	11.2 EER 12.9 IEER before 1/1/2023 14.8 IEER after 1/1/2023	AHRI 340/360
		All other		11.0 EER 12.7 IEER before 1/1/2023 14.6 IEER after 1/1/2023	
	Electric resistance (or none)	11.0 EER 12.4 IEER before 1/1/2023 14.2 IEER after 1/1/2023			
	All other	10.8 EER 12.2 IEER before 1/1/2023 14.0 IEER after 1/1/2023			
≥ 135,000 Btu/h and < 240,000 Btu/h	All other	All other	All other	10.8 EER 12.2 IEER before 1/1/2023 14.0 IEER after 1/1/2023	All other

TABLE C403.3.2(1)—continued  
ELECTRICALLY OPERATED UNITARY AIR CONDITIONERS AND CONDENSING UNITS—MINIMUM EFFICIENCY REQUIREMENTS<sup>a, d</sup>

EQUIPMENT TYPE	SIZE CATEGORY	HEADING SECTION TYPE	SUBCATEGORY OR RATING CONDITION	MINIMUM EFFICIENCY	TEST PROCEDURE <sup>e</sup>
Air conditioners, air cooled (continued)	≥ 240,000 Btu/h and < 760,000 Btu/h	Electric resistance (or none)	Split system and single package	10.0 EER 11.6 IEER before 1/1/2023 13.2 IEER after 1/1/2023	AHRI 340/360
		All other		9.8 EER 11.4 IEER before 1/1/2023 13.0 IEER after 1/1/2023	
	≥ 760,000 Btu/h	Electric resistance (or none)		9.7 EER 11.2 IEER before 1/1/2023 12.5 IEER after 1/1/2023	
		All other		9.5 EER 11.0 IEER before 1/1/2023 12.3 IEER after 1/1/2023	
Air conditioners, water cooled	< 65,000 Btu/h	All	Split system and single package	12.1 EER 12.3 IEER	AHRI 210/240
	≥ 65,000 Btu/h and < 135,000 Btu/h	Electric resistance (or none)		12.1 EER 13.9 IEER	AHRI 340/360
		All other		11.9 EER 13.7 IEER	
	≥ 135,000 Btu/h and < 240,000 Btu/h	Electric resistance (or none)		12.5 EER 13.9 IEER	
		All other		12.3 EER 13.7 IEER	
	≥ 240,000 Btu/h and < 760,000 Btu/h	Electric resistance (or none)		12.4 EER 13.6 IEER	
		All other		12.2 EER 13.4 IEER	
	≥ 760,000 Btu/h	Electric resistance (or none)		12.2 EER 13.5 IEER	
All other		12.0 EER 13.3 IEER			

TABLE C403.3.2(1)—continued  
ELECTRICALLY OPERATED UNITARY AIR CONDITIONERS AND CONDENSING UNITS—MINIMUM EFFICIENCY REQUIREMENTS<sup>a, d</sup>

EQUIPMENT TYPE	SIZE CATEGORY	HEADING SECTION TYPE	SUBCATEGORY OR RATING CONDITION	MINIMUM EFFICIENCY	TEST PROCEDURE <sup>a</sup>
Air conditioners, evaporatively cooled	< 65,000 Btu/h <sup>b</sup>	All	Split system and single package	12.1 EER 12.3 IEER	AHRI 210/240
	≥ 65,000 Btu/h and < 135,000 Btu/h	Electric resistance (or none)		12.1 EER 12.3 IEER	AHRI 340/360
		All other		11.9 EER 12.1 IEER	
	≥ 135,000 Btu/h and < 240,000 Btu/h	Electric resistance (or none)		12.0 EER 12.2 IEER	
		All other		11.8 EER 12.0 IEER	
	≥ 240,000 Btu/h and < 760,000 Btu/h	Electric resistance (or none)		11.9 EER 12.1 IEER	
		All other		11.7 EER 11.9 IEER	
≥ 760,000 Btu/h	Electric resistance (or none)	11.7 EER 11.9 IEER			
All other	11.5 EER 11.7 IEER				
Condensing units, air cooled	≥ 135,000 Btu/h	—	—	10.5 EER 11.8 IEER	AHRI 365
Condensing units, water cooled	≥ 135,000 Btu/h	—	—	13.5 EER 14.0 IEER	AHRI 365
Condensing units, evaporatively cooled	≥ 135,000 Btu/h	—	—	13.5 EER 14.0 IEER	AHRI 365

**SUMMER COINCIDENT PEAK DEMAND SAVINGS**

$$\Delta kW = [(kBtu/hr) * (1/EER_{exist}) * ESF_{Cooling} + 0.746 * FanHP * ESF_{Fan}] * CF$$

Where:

- EER<sub>exist</sub> = Energy Efficiency Ratio of the existing equipment (assume the following conversion from SEER to EER for calculation of peak savings: EER = (-0.02 \* SEER<sup>2</sup>) + (1.12 \* SEER))  
= Actual, or assume Code base in place at the original time of existing unit installation
- CF<sub>SSP</sub> = Summer System Peak Coincidence Factor for Commercial cooling (during system peak hour)  
= 91.3%
- CF<sub>PJM</sub> = PJM Summer Peak Coincidence Factor for Commercial cooling (average during peak period)  
= 47.8%

**FOSSIL FUEL SAVINGS**

N/A

**WATER AND OTHER NON-ENERGY IMPACT DESCRIPTIONS AND CALCULATION**

N/A

**DEEMED O&M COST ADJUSTMENT CALCULATION**

N/A

**MEASURE CODE: CI-HVC-HSRM-V04-240101**

**REVIEW DEADLINE: 1/1/2025**

## 4.4.52 Hydronic Heating Radiator Replacement

### DESCRIPTION

A hydronic heating radiator's capacity to evenly and consistently distribute heat throughout a space, utilizing piped hot-water or steam is often stymied by the buildup of mineral deposits and contaminants. Past research has shown that eliminating these deposits regularizes flow rate and boiler behavior, in effect restoring a radiator to a like-new condition.<sup>1022</sup> A space is heated more effectively in this improved state and this condition furthermore reduces the need for continual (additionally wasteful) thermostat readjustment. A straightforward process to achieve this is to simply replace the fouled hydronic radiator pipe system with a new system equivalent to the replaced system's pre-fouled performance levels. This avoids any possible inconsistencies associated with a radiator-flushing procedure (e.g., less-than-expected savings, failure to return the pipe system to like-new condition, inability to treat a system due to its interlinking with separate domestic hot water systems, etc.) and furthermore ensures that expected savings are realized. This measure offers benefits during heating seasons for natural gas, is applicable to both residential and commercial applications, and considers hot water or steam as the source of thermal energy (seeing as both heat transfer mediums can theoretically act as the intermediary from which contaminants precipitate).

The calculations of savings presented in this section are furthermore normalized to apply to both commercial and multi-family residential applications and additionally consider the differences between the physical characteristics of hot water or steam (e.g., thermal resistance, temperature, convective heat transfer) when computing the savings tabulated in the 'Annual Normalized Gas Savings per Surface Area' table shown below.

This measure was developed to be applicable to the following program types: RF

If applied to other program types, the measure savings should be verified.

### DEFINITION OF EFFICIENT EQUIPMENT

The efficient equipment is a new replacement hydronic radiator free of mineral deposit scaling and/or sludge which must reflect the capacity of the replaced system's pre-fouled performance levels (i.e., a "like-for-like" replacement).

### DEFINITION OF BASELINE EQUIPMENT

The baseline condition is the hydronic radiator being replaced, which has shown decreased performance due to a high degree of mineral deposit scaling and sludge buildup. The built-up scale inside the radiators is predominantly assumed to be Iron Oxide ( $\text{Fe}_3\text{O}_4$ ) and to have a thermal conductivity of 3.01 Btu/hr-ft·°F.<sup>1023</sup>

A "standard scaled" radiator is assumed to be 10% clogged and a "heavily scaled" radiator is assumed to be 30% clogged. An implementation contractor will need to verify the baseline condition of the radiator, to classify it as either standard or heavily scaled. Measuring the surface temperature spread using an infrared temperature thermometer can be used to determine this; surface temperature spot readings below 180°F for a steam system and below 100°F for a hot water system can be labeled as 'standard scaling'. A "heavily scaled" radiator is assumed to one with surface temperature spots below 150°F for a steam system and below 90°F for a hot water system.<sup>1024</sup> This should be verified by the implementation contractor by measuring the radiator surface temperature at multiple points when operating the boiler system at full load and when outdoor air temperatures are below 20°F. Implementer should strive to perform spot readings on at least 10% of total radiators. Based on the collected spot temperature readings, qualify the facility as either standard scaled or heavily scaled.

<sup>1022</sup> Day, Paul and Balmer, Paul. "Independent Study Shows Sludge Build-up Significantly Affects Hydronic Heating System Performance," May, 2011. Accessed 03/25/20.

<sup>1023</sup> The thermal properties of Iron Oxide are referenced from the following: Takeda, Mikako and Onishi, Takashi and Nakakubo, Shouhei and Fujimoto, Shinji. "Physical Properties of Iron-Oxide Scales on Si-Containing Steels at High Temperature," Materials Transactions Vol 50, No. 9 (2009): pp. 2242-2246. doi:10.2320/matertrans.M2009097.

<sup>1024</sup> Assumptions based on typical operating hot water/steam supply temperatures for cast-iron radiators of 170°F and 220°F. 'Clogged' surface temperature assumptions based on temperatures below which performance of radiators starts dropping considerably.

The baseline for this measure is aging scaled radiators. Most facilities tend not to replace their old radiators and often tend to add a means of secondary heating. This measure is aimed at these facilities to incentivize the replacement of these old radiators.

**DEEMED LIFETIME OF EFFICIENT EQUIPMENT**

Hydronic radiator systems are extremely diverse, in size, scope or application, and in the materials utilized for the heat transfer surface. Cast iron, steel, and copper piping are common in radiators, as are polymer materials such as polyethylene (often seen in newer radiator systems). As such, an estimated useful life will naturally vary based on these circumstances and the quality of previous radiator maintenance. The estimated useful life of a typical hydronic radiator has been approximated to be 25 years.<sup>1025</sup>

**DEEMED MEASURE COST**

The measure cost is the full cost of removing the existing unit and installing a new one. The actual program cost should be used. If unknown, assume \$61.35 per vertical column.<sup>1026</sup> For more details on the definition of section of a radiator, the cited reference can be used.<sup>1027</sup>

**LOADSHAPE**

N/A

**COINCIDENCE FACTOR**

N/A

---

---

**Algorithm**

---

---

**CALCULATION OF ENERGY SAVINGS**

**ELECTRIC ENERGY SAVINGS**

N/A

**SUMMER COINCIDENT PEAK DEMAND SAVINGS**

N/A

**FOSSIL FUEL SAVINGS**

The annual natural gas savings per area for radiator replacement is calculated by determining the difference between the heat transfer from the replacement radiator and the radiator being replaced.

---

<sup>1025</sup> Examples from the following source use “system design lives” of 20 and 25 years, and cite the service lifetimes of a cast iron hydronic radiator’s boiler to often be “30 years or more”.

Siegenthaler, John, Modern Hydronic Heating: For Residential and Light Commercial Buildings 3rd Edition, Delmar Cengage Learning, Clifton Park, New York, 2012.

There is limited information available on system lifetimes of hydronic radiators, as well-built and well-maintained systems tend to last for decades. We assume that a midpoint of the “design-lives” cited above (25) can correspond to the time a hydronic radiator system begins to underperform, with one known reason for underperformance (which also happens to be the focus of this measure) being the corrosion of piping materials and/or the presence of precipitated mineral contaminates restricting flow rate and thus hindering heat transfer.

<sup>1026</sup> Average calculated from RSMean Cost Data 2020 for Hydronic Heating Radiators, Cast Iron.

<sup>1027</sup> Express Radiant, “Calculating Radiator Output”, 2014. This reference shows a representation of how a section of a typical radiator is defined.

$$\Delta Therms = \frac{[Q_{New} - Q_{Base}] * EFLH}{(100,000 * \eta)}$$

$$Q_{Base} = \frac{(A * \Delta T)}{R_{Base}}$$

$$R_{Base} = R_{conv1} + R_{cond} + \left( \frac{R_{rad} * R_{conv2}}{R_{rad} + R_{conv2}} \right)$$

$$Q_{New} = \frac{(A * \Delta T)}{R_{New}}$$

The thermal resistance components remain the same as the above ( $R_{Base}$ ), with the exception of the contaminate oxide layer which is no longer present in the post-case:

$$R_{New} = R_{conv1} + \left( \frac{R_{rad} * R_{conv2}}{R_{rad} + R_{conv2}} \right)$$

Where:

$Q_{New}$  (Btu/hr) = The heat emission from the replacement hydronic heating system

$Q_{Base}$  (Btu/hr) = The heat emission from the hydronic heating system being replaced

$EFLH$  = Effective full load hours based on the climate zone

**Heating Season Recirculation Hours**

Climate Zone	Hours
1 – Rockford	5,039
2 – Chicago	4,963
3 – Springfield	4,495
4 – Belleville	4,021
5 – Marion	4,150

$\eta$  = Actual Thermal Efficiency of the Heating Equipment (if unknown, use 81.9% for water boilers<sup>1028</sup> and 80.7% for steam boilers<sup>1029</sup>)

100,000 = conversion factor (1 Therm = 100,000 Btu)

$A$  (ft<sup>2</sup>) = the effective area of heat transfer of the radiator<sup>1030</sup>

$\Delta T$  (°F) = the temperature difference between the supply fluid temperature and the conditioned room design temperature

$R_{Base}$  (ft<sup>2</sup> °F hr/ BTU) = the overall thermal resistance of the system before replacement

$R_{New}$  (ft<sup>2</sup> °F hr/ BTU) = the overall thermal resistance of the system after replacement

<sup>1028</sup> Average efficiencies of units from the California Energy Commission (CEC).

<sup>1029</sup> Ibid.

<sup>1030</sup> The pipe diameter is assumed to be 2 inches and the thickness of mineral deposits in a fouled radiator (which, recall, are assumed to be composed of iron oxide), is a function of the percent of the pipe diameter which is clogged and the assumed pipe diameter.

$R_{conv1}$  (ft<sup>2</sup> °F hr/ BTU) = the thermal resistance of convection between the hot water/steam and the radiator<sup>1031</sup>

$R_{cond}$  (ft<sup>2</sup> °F hr/ BTU) = the thermal resistance of conduction in the oxide layer buildup<sup>1032</sup>

$R_{rad}$  (ft<sup>2</sup> °F hr/ BTU) = the thermal resistance of radiation between the radiator and the conditioned space<sup>1033</sup>

$R_{conv2}$  (ft<sup>2</sup> °F hr/ BTU) = the thermal resistance of convection between radiator and the conditioned space<sup>1034</sup>

**Annual Normalized Gas Savings per Surface Area (therms/ft<sup>2</sup>)**

HVAC System Type		1 – Rockford	2 – Chicago	3 – Springfield	4 – Belleville	5 – Marion
Hot Water Radiator	Standard Scaling	0.115	0.113	0.102	0.091	0.094
	Heavy Scaling	0.337	0.332	0.301	0.269	0.278
Steam Radiator	Standard Scaling	0.170	0.168	0.152	0.136	0.140
	Heavy Scaling	0.501	0.493	0.447	0.400	0.413

$$\Delta Therms = HS_{cz} * Area_{radiator}$$

Where:

$HS_{cz}$  = Annual heating savings per area of radiator by climate zone, values from ‘Annual Normalized Gas Savings per Surface Area’ table above.

$Area_{radiator}$  = Total surface area of radiator (ft<sup>2</sup>)

Example:

**For example,** a building in Climate Zone 1 is equipped with a heavily scaled steam radiator system. The surface area of the replacement and radiator being replaced was calculated to be 85 ft<sup>2</sup>.

$$\begin{aligned} \Delta Therms &= \text{Annual Normalized Gas Savings (therms/ft}^2\text{)} * \text{Surface Area (ft}^2\text{)} \\ &= 0.501 * 85 \\ &= 42.59 \text{ therms annually} \end{aligned}$$

**WATER AND OTHER NON-ENERGY IMPACT DESCRIPTIONS AND CALCULATION**

N/A

**DEEMED O&M COST ADJUSTMENT CALCULATION**

N/A

<sup>1031</sup> For a steam system, the supply temperature is assumed to be 220°F. For a hot water system, the supply temperature is assumed to be 170°F. This implies convective heat transfer coefficients of 1,100 Btu/hr·ft<sup>2</sup>·°F and 700 Btu/hr·ft<sup>2</sup>·°F for steam and hot water, respectively, the inverses of which equate to steam’s or hot water’s thermal resistances.

<sup>1032</sup> Recall that iron oxide has a thermal conductivity of 3.01 Btu/hr·ft<sup>2</sup>·°F.

<sup>1033</sup> Stefan-Boltzmann constant is assumed to be 1.714×10<sup>-9</sup> BTU·hr<sup>-1</sup>·ft<sup>-2</sup>·°R<sup>-4</sup>.

<sup>1034</sup> The convective heat transfer coefficient of Air is assumed to be 1.844 Btu/hr·ft<sup>2</sup>·°F. Emissivity of radiator surface is assumed to be 0.6.



**MEASURE CODE: CI-HVC-HHRR-V02-240101**

**REVIEW DEADLINE: 1/1/2028**

## 4.4.53 HVAC Supply, Return and Exhaust Fans – Fan Energy Index

### DESCRIPTION

The Fan Energy Index (FEI) is a new fan efficiency metric that allows for the comparison of different fans at application specific operating conditions. This is a significant improvement over the current Fan Efficiency Grade metric, which is defined at a rated condition. FEI is incorporated in ASHRAE 90.1-2019 and IECC-2021. These codes set the baseline FEI as 1.0 for constant speed fan operation and 0.95 for variable speed fan operation. More efficient fans will have FEI greater than these values. It is only applicable to stand-alone fans, and not for fans embedded in packaged equipment. This measure results in fan energy savings compared to a baseline scenario of an existing fan's FEI or code minimum FEI for a new fan.

Note this measure should be used for evaluating more efficient over baseline fans with the same control system. Measure 4.4.26 should be utilized to evaluate control system modifications. When combining the two measures, the  $FEP_{New}$  value should be used to replace the  $\left(0.746 \times HP \times \frac{LF}{\eta_{motor}}\right)$  term in Measure 4.4.26 Variable Speed Drive for HVAC Supply and Return Fans.

This measure serves the market for commercial and industrial buildings.

This measure was developed to be applicable to the following program types: TOS, NC, and EREP. If applied to other program types, the measure savings should be verified.

### DEFINITION OF EFFICIENT EQUIPMENT

In order for this characterization to apply, the efficient equipment is assumed to exceed the efficiency requirements defined by the program.

### DEFINITION OF BASELINE EQUIPMENT

For Time of Sale (TOS): The baseline equipment is assumed to meet the efficiency requirements within the IECC code in effect on the date of the building permit or sale (if unknown assume IECC 2021).

For New Construction (NC): The baseline equipment is assumed to meet the efficiency requirements within the IECC code in effect on the date of the building permit (if unknown assume IECC 2021). As code requirements and adoption can differ from municipality to municipality, the user should verify which version of code is applicable given these constraints.

For Early Replacement (EREP): The baseline equipment is assumed to be the existing fan.

### DEEMED LIFETIME OF EFFICIENT EQUIPMENT

For variable speed fans, the expected measure life is 15 years.<sup>1035</sup>

For constant speed fans, the expected measure life is 18 years for centrifugal housed and unhoused fans. The expected measure life is 25 years for all other fan types.<sup>1036</sup>

---

<sup>1035</sup> "NEEP Incremental Cost Study – Phase II Final Report, Navigant, 2013."

<sup>1036</sup> U.S. Department of Energy Fans and Blowers Working Group, Energy Conservation Program: Final Determination of Fans and Blowers as Covered Equipment

**DEEMED MEASURE COST**

Actual measure costs should be used if available. Default measure costs are noted below for fans with FEI greater than 1.0<sup>1037</sup>. These costs are established at an FEI of 1.2. To calculate the cost for a fan with different FEI, prorate the default cost with the actual FEI (see example).

**TOS and NC**

Fan Type	Cost (\$/hp)	
	Small (< 10 hp)	Large (>= 10 hp)
Axial Cylindrical Housed	\$264	\$87
Panel	\$29	\$10
Centrifugal Housed	\$199	\$55
Centrifugal Unhoused	\$76	\$18
Inline and Mixed Flow	\$297	\$97
Radial	\$119	\$33
Power Roof Ventilator	\$140	\$42
Axial Cylindrical Housed	\$264	\$87

**EREP**

Fan Type	Cost (\$/hp)	
	Small (< 10 hp)	Large (>= 10 hp)
Axial Cylindrical Housed	\$3,218	\$1,068
Panel	\$319	\$104
Centrifugal Housed	\$1,381	\$382
Centrifugal Unhoused	\$827	\$195
Inline and Mixed Flow	\$2,301	\$751
Radial	\$1,570	\$434
Power Roof Ventilator	\$1,536	\$460
Axial Cylindrical Housed	\$3,218	\$1,068

**For example**, the default deemed measure cost of installing a new construction, centrifugal housed, 5 hp fan with FEI = 1.3 is:

Deemed Measure Costs (\$) = \$199 per hp \* 5 hp \* (1.3 / 1.2) = \$1,078

**LOADSHAPE**

- Loadshape C39 – VFD – Supply fans <10 HP
- Loadshape C40 – VFD – Return fans <10 HP
- Loadshape C41 – VFD – Exhaust fans <10 HP

**COINCIDENCE FACTOR**

The demand savings factor (DSF) is already based upon coincident savings, and thus there is no additional coincidence factor for this characterization.

<sup>1037</sup> Costs are based on the U.S. Department of Energy Fans and Blowers Working Group spreadsheet: EERE-2013-BT-STD-0006-0189\_attachment\_1.xlsx.

**Algorithm**

**CALCULATION OF ENERGY SAVINGS**

**ELECTRIC ENERGY SAVINGS**

Note this measure should be used for evaluating more efficient over baseline fans with the same control system. Measure 4.4.26 Variable Speed Drives for HVAC Supply and Return Fans should be utilized to evaluate control system modifications. When combining the two measures, the  $FEP_{New}$  value should be used to replace the  $(0.746 \times HP \times \frac{LF}{\eta_{motor}})$  term in Measure 4.4.26.

$$\Delta kWh_{fan} = FEP_{New} * \left( \frac{FEI_{New}}{FEI_{Base}} - 1 \right) * RHRS * \sum_{0\%}^{100\%} (\%FF * PLR)$$

$$\Delta kWh_{total} = \Delta kWh_{fan} * (1 + IE_{energy})$$

Where:

- $\Delta kWh_{fan}$  = Fan-only annual energy savings (kWh)
- $FEP_{New}$  = Fan Electrical Power of new fan at 100% flow fraction (kW)
- $FEI_{New}$  = Fan Energy Index of new fan at 100% flow fraction (-)
- $FEI_{Base}$  = Fan Energy Index of baseline fan at 100% flow fraction (-)

**TOS and NC:**  $FEI_{base}$  is defined per IECC.  
 = 0.95 for Variable Speed Fan  
 = 1.0 for Constant Speed Fan

**EREP:**  $FEI_{base}$  is defined as existing fan efficiency. If unknown, use:<sup>1038</sup>

Fan Type	Drive Type		
	Variable Speed – Belt	Constant Speed – Belt	Constant Speed – Direct
Axial Cylindrical Housed	0.88	0.88	0.97
Panel	0.95	0.95	0.88
Centrifugal Housed	0.92	0.92	0.92
Centrifugal Unhoused	0.94	0.94	1.03
Inline and Mixed Flow	0.79	0.79	0.77
Radial	0.81	0.81	0.94
Power Roof Ventilator	0.82	0.82	0.76

$RHRS$  = Annual operating hours for fan based on building type

<sup>1038</sup> “Fan Energy Index Market Research: Final Report”, prepared for ComEd by Slipstream, May 2021.

Default hours are provided for HVAC applications which vary by HVAC application and building type.<sup>1039</sup> When available (provided via Energy Management Software or metered), actual hours should be used.

Building Type	Total Fan Run Hours	Model Source
Assembly	7235	eQuest
Assisted Living	8760	eQuest
Auto Dealership	7451	OpenStudio
College	4836	OpenStudio
Convenience Store	7004	eQuest
Drug Store	7156	OpenStudio
Elementary School	3765	OpenStudio
Emergency Services	8760	OpenStudio
Garage	7357	eQuest
Grocery	8543	OpenStudio
Healthcare Clinic	4314	OpenStudio
High School	3460	OpenStudio
Hospital – VAV econ	4666	OpenStudio
Hospital – CAV econ	8021	OpenStudio
Hospital – CAV no econ	7924	OpenStudio
Hospital – FCU	4055	OpenStudio
Manufacturing Facility	8706	eQuest
MF – High Rise	8760	OpenStudio
MF – Mid Rise	8760	OpenStudio
Hotel/Motel – Guest	2409	OpenStudio
Hotel/Motel – Common	8683	OpenStudio
Movie Theater	7505	eQuest
Office – High Rise – VAV econ	2369	OpenStudio
Office – High Rise – CAV econ	2279	OpenStudio
Office – High Rise – CAV no econ	5303	OpenStudio
Office – High Rise – FCU	1648	OpenStudio
Office – Low Rise	6345	OpenStudio
Office – Mid Rise	3440	OpenStudio
Religious Building	7380	eQuest
Restaurant	7302	OpenStudio
Retail – Department Store	7155	OpenStudio
Retail – Strip Mall	6921	OpenStudio
Warehouse	6832	OpenStudio
Unknown	6241	n/a

%FF = Percentage of run-time spent within a given flow fraction range<sup>1040</sup>

Flow Fraction (% of design cfm)	Percent of Time at Flow Fraction
0% to 10%	0.0%

<sup>1039</sup> Hours per year are estimated using the eQuest or OpenStudio models as the total number of hours the fans are operating for heating, cooling and ventilation for each building type.

<sup>1040</sup> Default Fan Duty Cycle Based on 2012 ASHRAE Handbook; HVAC Systems and Equipment (pg. 45.11, Figure 12)

Flow Fraction (% of design cfm)	Percent of Time at Flow Fraction
10% to 20%	1.0%
20% to 30%	5.5%
30% to 40%	15.5%
40% to 50%	22.0%
50% to 60%	25.0%
60% to 70%	19.0%
70% to 80%	8.5%
80% to 90%	3.0%
90% to 100%	0.5%

PLR = Part load ratio for a given flow fraction range<sup>1041</sup>

Control Type	Flow Fraction									
	10%	20%	30%	40%	50%	60%	70%	80%	90%	100%
No Control or Bypass Damper	1.00	1.00	1.00	1.00	1.00	1.00	1.00	1.00	1.00	1.00
Discharge Dampers	0.46	0.55	0.63	0.70	0.77	0.83	0.88	0.93	0.97	1.00
Outlet Damper, BI & Airfoil Fans	0.53	0.53	0.57	0.64	0.72	0.80	0.89	0.96	1.02	1.05
Inlet Damper Box	0.56	0.60	0.62	0.64	0.66	0.69	0.74	0.81	0.92	1.07
Inlet Guide Vane, BI & Airfoil Fans	0.53	0.56	0.57	0.59	0.60	0.62	0.67	0.74	0.85	1.00
Inlet Vane Dampers	0.38	0.40	0.42	0.44	0.48	0.53	0.60	0.70	0.83	0.99
Outlet Damper, FC Fans	0.22	0.26	0.30	0.37	0.45	0.54	0.65	0.77	0.91	1.06
Eddy Current Drives	0.17	0.20	0.25	0.32	0.41	0.51	0.63	0.76	0.90	1.04
Inlet Guide Vane, FC Fans	0.21	0.22	0.23	0.26	0.31	0.39	0.49	0.63	0.81	1.04
VFD with duct static pressure controls	0.09	0.10	0.11	0.15	0.20	0.29	0.41	0.57	0.76	1.01
VFD with low/no duct static pressure	0.05	0.06	0.09	0.12	0.18	0.27	0.39	0.55	0.75	1.00

Provided below are the resultant values based upon the defaults provided above:

Control Type	$\sum_{0\%}^{100\%} (\%FF \times PLR)$
No Control or Bypass Damper	1.00
Discharge Dampers	0.80
Outlet Damper, BI & Airfoil Fans	0.78
Inlet Damper Box	0.69
Inlet Guide Vane, BI & Airfoil Fans	0.63
Inlet Vane Dampers	0.53
Outlet Damper, FC Fans	0.53
Eddy Current Drives	0.49
Inlet Guide Vane, FC Fans	0.39
VFD with duct static pressure controls	0.30
VFD with low/no duct static pressure	0.27

<sup>1041</sup> Methodology developed and tested in Del Balso, Ryan Joseph. "Investigation into the Reliability of Energy Efficiency/Demand Side Management Savings Estimates for Variable Frequency Drives in Commercial Applications". A project report submitted to the Faculty of the Graduate School of the University of Colorado, 2013.

$\Delta kWh_{total}$  = Total project annual energy savings (kWh)  
 $IE_{energy}$  = HVAC interactive effects factor for energy (default = 15.7%)

**SUMMER COINCIDENT PEAK DEMAND SAVINGS**

$$\Delta kW_{fan} = FEP_{New} * \left( \frac{FEI_{New}}{FEI_{Base}} - 1 \right) * PLR_{FFpeak}$$

$$\Delta kW_{total} = \Delta kW_{fan} * (1 + IE_{demand})$$

Where:

$\Delta kW_{fan}$  = Fan-only summer coincident peak demand impact (kW)  
 $PLR_{FFpeak}$  = The part load ratio for the average flow fraction between the peak daytime hours during the weekday peak time period based on the baseline flow control type (default average flow fraction during peak period = 90%)  
 $\Delta kW_{total}$  = Total project summer coincident peak demand impact (kW)  
 $IE_{demand}$  = HVAC interactive effects factor summer coincident peak demand (default = 15.7%)

**FOSSIL FUEL SAVINGS**

There are no expected fossil fuel impacts for this measure.

**WATER AND OTHER NON-ENERGY IMPACT DESCRIPTIONS AND CALCULATION**

N/A

**DEEMED O&M COST ADJUSTMENT CALCULATION**

N/A

**MEASURE CODE: CI-HVC-FFEI-V03-240101**

**REVIEW DEADLINE: 1/1/2025**

#### 4.4.54 Process Heating Boiler

##### DESCRIPTION

A process boiler is a pressure vessel that transfers heat to water for industrial process applications. Process boilers can be configured as an integrated packaged boiler or as modular instantaneous boiler arrays. This measure is applicable to boilers which serve process loads in a facility.

Modular instantaneous boilers are a recent addition to the industrial/commercial market aimed at addressing some of the drawbacks of conventional large boiler systems. They achieve high efficiencies by using multiple smaller sized modules to meet the minimum demand. They allow each boiler to operate at or close to full rated load most of the time, with reduced standby losses. The boiler design is a low water mass pressure vessel that produces steam at operating pressure rapidly then shuts off the combustion system once the demand requirement is met, thereby saving fuel.

Traditional packaged boiler systems are designed to provide the entire steam load of the facility using one or two boilers. Typically, the boiler horsepower is sized for the maximum steam load required at any facility. However, the average steam load of any facility is only 30 to 40 percent of this, and the average load on the boiler system is low. Therefore, they are not able to achieve these high efficiencies.<sup>1042</sup>

This measure was developed to be applicable to the following program types: NC, EREP, TOS.

##### DEFINITION OF EFFICIENT EQUIPMENT

The efficient case is the replacement of a non-residential standard efficiency process boiler for process loads with a high-efficiency process boiler exceeding the energy conservation standards outlined below. The efficient unit may either be a conventional packaged boiler or a modular boiler array system. Non-residential commercial boilers are defined as having an input rating greater than 300,000 Btu/h.

##### DEFINITION OF BASELINE EQUIPMENT

For Time of Sale and New Construction:

Gas-fired boilers, termed as commercial packaged boilers, manufactured after January 10, 2023 must comply with the standards defined in the Code of Federal Regulations, 10 CFR 431.87.<sup>1043</sup>

Note, for natural draft steam boilers, as IECC 2021, Illinois state energy code, expected to become effective statewide in 2023, exceeds the minimum federal efficiency standards, it was replaced in favor of the more aggressive thermal efficiency values in the table below. For new construction applications where the permitting date is prior to the state’s adoption of IECC 2021 it is recommended to use the applicable edition of IECC corresponding to that timeline. As code requirements and adoption can differ from municipality to municipality, the user should verify which version of code is applicable given these constraints.

**Boiler baseline efficiency standards**

Boiler Type	Efficiency <sup>1044</sup>
Hot Water Boiler $\geq 300,000$ Btu/h and $\leq 2,500,000$ Btu/h	84% $E_T$
Hot Water Boiler $> 2,500,000$ Btu/h and $\leq 10,000,000$ Btu/h	85% $E_C$
Hot Water Boiler $> 10,000,000$ Btu/h	82% $E_C$

<sup>1042</sup> Modular boiler arrays have greater combustion efficiencies as compared to traditional steam boilers. This has been verified via a field study done by Nicor Gas ETP. The study covered an industrial manufacturing facility with (10) modular process steam boiler systems; the effective efficiency was found to be in line with the rated manufacturer efficiency of 87%.

<sup>1043</sup> Boilers  $\geq 300,000$  Btu/hr, Code of Federal Regulations, 10 CFR 431.87, Table 1 – Commercial Packaged Boiler Energy Conservation Standards.

<sup>1044</sup> Ibid.



Boiler Type	Efficiency <sup>1044</sup>
Steam Boiler $\geq 300,000$ Btu/h and $\leq 2,500,000$ Btu/h	81% E <sub>T</sub>
Steam Boiler $\geq 2,500,000$ Btu/h and $\leq 10,000,000$ Btu/h	82% E <sub>T</sub>
Steam Boiler $> 10,000,000$ Btu/h	79% E <sub>T</sub>

where E<sub>T</sub> means “thermal efficiency” and E<sub>C</sub> means “combustion efficiency” as defined in 10 CFR 431.82.

For early replacement: The efficiency of the existing equipment should be used for the assumed remaining useful life of the equipment and a new baseline equipment as described above for the remainder of the measure life.

**DEEMED LIFETIME OF EFFICIENT EQUIPMENT**

The expected measure life is assumed to be 25 years.<sup>1045</sup>

For EREP, the remaining useful life of the existing equipment is assumed to be 1/3<sup>rd</sup> of EUL (25/3) or 8 years.

**DEEMED MEASURE COST**

The measure cost for this technology is tiered based on the boiler type and combustion efficiencies. As installation costs for the base case and the measure case units are assumed to be the same, labor costs are not specified for this measure.

**Incremental and Gross Measure costs for Process Boilers**

Boiler Type	Incremental Measure Cost (\$/Kbtu) <sup>1046</sup>	Full Measure Cost (\$/Kbtu) <sup>1047</sup>
Hot Water Boiler $\geq 85\%$ E <sub>C</sub> and $< 90\%$ E <sub>C</sub>	\$2.17	\$12.94
Hot Water Boiler $\geq 90\%$ E <sub>C</sub>	\$12.17	\$22.95
Steam Boiler $\geq 83\%$ E <sub>C</sub> and $< 85\%$ E <sub>C</sub>	\$4.35	\$19.24
Modular Steam Boiler Arrays ( $\geq 85\%$ E <sub>C</sub> ) <sup>1048</sup>	Custom	

A deferred baseline replacement cost, consistent with the delta between the full measure cost and incremental cost above should be assumed after the remaining useful life of the existing equipment.

**LOADSHAPE**

N/A

**COINCIDENCE FACTOR**

N/A

---

**Algorithm**

---

<sup>1045</sup> <https://www.govinfo.gov/content/pkg/FR-2020-01-10/pdf/2019-26356.pdf>.

<sup>1046</sup> California ETRM measure “Process Boiler”, <https://www.caetrm.com/measure/SWWH008/01/>, accessed April 16, 2021..

<sup>1047</sup> Ibid.

<sup>1048</sup> Miura Modular Boilers, <https://s29958.pcdn.co/wp-content/uploads/2019/03/LXBrochure2016.pdf>

**CALCULATION OF ENERGY SAVINGS**

**ELECTRIC ENERGY SAVINGS**

N/A

**SUMMER COINCIDENT PEAK DEMAND SAVINGS**

N/A

**FOSSIL FUEL SAVINGS**

For first 8 years:

$$\Delta Therms = 8,766 * Capacity * UF * \left( \frac{Efficiency_{EE}}{Efficiency_{Exist}} - 1 \right) * \frac{1}{100,000}$$

For remaining 17 years:

$$\Delta Therms = 8,766 * Capacity * UF * \left( \frac{Efficiency_{EE}}{Efficiency_{Base}} - 1 \right) * \frac{1}{100,000}$$

Where:

- 8,766 = Annual Operating hours for Process Boilers  
The assumed hours of operation are based on continual plant operation. Variation in plant operating hours is accounted for in the utilization factor. While the boiler may operate during the entire year, it may not be operating at its full rated load.
- Capacity = Nominal heating input capacity boiler size for high-efficiency unit (Btu/hr)
- UF = Utilization Factor  
= Custom or if unknown 41.9%<sup>1049</sup>
- Efficiency<sub>Exist</sub> = Existing boiler efficiency rating,  
= Actual
- Efficiency<sub>Base</sub> = Baseline boiler efficiency rating, dependent on year and boiler type or use actual operating efficiencies for early replacements. See table in “Definition of Baseline Equipment.”
- Efficiency<sub>EE</sub> = Efficient boiler efficiency rating for packaged or modular boiler system  
= Actual value, specified to one significant digit (i.e., 95.7%)
- 100,000 = Constant to convert from Btu to therm

**For example**, an 800,000 Btu/hr gas-fired process steam boiler with a thermal efficiency rating of 87% is installed replacing a similar sized natural draft steam boiler with baseline efficiency of 77%.

$$\begin{aligned} \Delta Therms &= 8,766 * 800,000 * 0.419 * (0.870 - 0.770) / 0.770 / 100,000 \\ &= 3,816 \text{ therms} \end{aligned}$$

<sup>1049</sup> Illinois TRM v9.0, measure 4.4.3 Process Boiler Tune-up, “Work Paper – Tune up for Boilers serving Space Heating and Process Load by Resource Solutions Group, January 2012”.

**WATER AND OTHER NON-ENERGY IMPACT DESCRIPTIONS AND CALCULATION**

N/A

**DEEMED O&M COST ADJUSTMENT CALCULATION**

N/A

**MEASURE CODE: CI-HVC-PHBO-V03-240101**

**REVIEW DEADLINE: 1/1/2027**

## 4.4.55 Commercial Gas Heat Pump

### DESCRIPTION

Heat pumps are a class of HVAC equipment that moves heat from cold source to warm sink, moving heat “uphill”. Often heat pumps can operate in reverse, using a reversing valve or other means to provide air conditioning (A/C) and space heating with the same product. If heat recovery is employed, the heat pump can also provide service hot water (SHW). Heat pumps generally involve the use of a refrigerant and utilize refrigeration cycles. Gas-fired heat pumps are a subset of heat pumps whose primary input drive energy is a gaseous fuel, instead of an electrically-driven compressor. Gas-fired heat pumps can be separated into two categories, *work-activated* technologies where a delivered fuel drives a prime mover (e.g., internal combustion engine) which supplies work to a refrigerant compressor, and *heat-activated* where the primary energy input to the heat pump cycle is thermal energy, often from fuel combustion, driving a sorption-type or other thermally-driven heat pump cycle.

This measure characterizes the installation of a commercial gas-fired heat pump for the following scenarios: NC, TS, EREP, and RF.

#### A. New Construction:

- i. The installation of a new commercial heat-activated (e.g., sorption-type) or work-activated (e.g., engine-driven) gas heat pump, certified to ANSI Z21.40.1 or ANSI Z21.40.2 respectively, that meets the criteria laid out in ANSI Z21.40.4 Performance Testing and Rating of Gas-Fired, Air Conditioning and Heat Pump Appliances.
- ii. Note the baseline in this case should be determined via EM&V and the algorithms are provided to allow savings to be calculated from any baseline condition defined in the Efficient Equipment section.

#### B. Time of Sale:

- i. The planned installation of a new gas heat pump meeting the efficiency standards laid out below that does not meet the criteria for early replacement as described in section C below.
- ii. Note the baseline in this case is the purchase of new equipment that is similar technology to existing equipment. Where unknown, the baseline should be determined via EM&V and the algorithms are provided to allow savings to be calculated from any baseline condition. The calculation of savings is dependent on whether an incentive for the installation has been provided by both a gas and electric utility, only an electric utility, or only a gas utility. SHW savings are calculated based on the fuel and efficiency of the existing unit.

#### C. Early Replacement/Retrofit:

- i. The early removal of functioning electric or gas space heating and/or cooling systems from service, prior to the natural end of life, and replacement with a new high efficiency commercial gas heat pump system.
- ii. Note the baseline in this case is the existing equipment being replaced. The calculation of savings is dependent on whether an incentive for the installation has been provided by both a gas and electric utility, only an electric utility, or only a gas utility. SHW savings are calculated based on the fuel and efficiency of the existing unit.
- iii. Early Replacement determination will be based on meeting the following conditions:
  - a. The existing unit is operational when replaced, or
  - b. The existing unit requires minor repairs to be operational, defined as costing less than 20% of the new baseline replacement cost (as defined in the Measured Cost section of the relevant equipment).
  - c. All other conditions will be considered Time of Sale.

For the Baseline efficiency of the existing unit being replaced:

- a. Use actual existing efficiency whenever possible.
- b. If the efficiency of the existing unit is unknown, use assumptions based on the Federal minimum standards provided in tables below.

- c. If the operational status or repair cost of the existing unit is unknown use time of sale assumptions.

**DEFINITION OF EFFICIENT EQUIPMENT**

Gaseous fuel heat pumps for space heating/cooling and domestic/service hot water heating. The table below shows the current gas heat pump products in two broad commercial categories – water heating and space heating/cooling. The table additionally lists applicable industry test methods and the primary efficiency metric.

**Table 1: Current Gas Heat Pump Products**

Equipment			Test Method	Efficiency Metric	
Category	Sector	Type	Industry	Primary Metric	Tested Performance
Water Heating	Commercial	Gas HPWH with or without storage tank	ANSI/ASHRAE 118.1	Coefficient of Performance (COP)	> 1.2 COP
Space Heating & Cooling	Commercial	Gas-fired air-conditioner or heat pump	ANSI Z21.40.4	Coefficient of Performance (COP) for heating / cooling	> 1.2 COP <sub>heating</sub> or > 1.0 COP <sub>cooling</sub>

**DEFINITION OF BASELINE EQUIPMENT**

The baseline equipment includes Service Hot Water, Space Heating, and Air-Conditioning.

New Construction:

The 2018 edition of the IECC (effective July 1, 2019 to the IECC 2021 effective date) and IECC 2021 (expected to become effective statewide in 2023) for commercial facilities and is applicable here.

To calculate savings with an electric baseline, the baseline equipment is assumed to be an Air Source Heat Pump meeting the state energy code efficiency level as outlined in Table 2 (IECC 2018, effective July 1, 2019 to IECC 2021 effective date) and Table 7 (IECC 2021, expected to become effective statewide in 2023) below.

To calculate savings with a chiller/unitary cooling system (Table 3, IECC 2018 and Table 8, IECC 2021) and boiler/furnace baseline (Table 4 and Table 9 for boilers and Table 5 and Table 10 for warm air furnaces), the baseline equipment is assumed to meet the minimum standard efficiencies as outlined in their respective tables.

To calculate savings with water heater applications, the baseline equipment is assumed to meet the minimum standard efficiencies outlined in Table 6 (IECC 2018) or Table 11 (IECC 2021).

As code requirements and adoption can differ from municipality to municipality, the user should verify which version of code is applicable given these constraints. If evaluation determines the applicable version of code, given location and timing, isn't an appropriate baseline due to supply constraints, low compliance, or other issues, the previous iteration of code may be used through 2023.

**Table 2: IECC 2018 Air-Source Heat Pumps Minimum Efficiency Requirements**

TABLE C403.3.2(2)  
MINIMUM EFFICIENCY REQUIREMENTS: ELECTRICALLY OPERATED UNITARY AND APPLIED HEAT PUMPS

EQUIPMENT TYPE	SIZE CATEGORY	HEATING SECTION TYPE	SUBCATEGORY OR RATING CONDITION	MINIMUM EFFICIENCY	TEST PROCEDURE <sup>a</sup>
Air cooled (cooling mode)	< 65,000 Btu/h <sup>b</sup>	All	Split System	14.0 SEER	AHRI 210/240
			Single Package	14.0 SEER	
Through-the-wall, air cooled	≤ 30,000 Btu/h <sup>b</sup>	All	Split System	12.0 SEER	
			Single Package	12.0 SEER	
Single-duct high-velocity air cooled	< 65,000 Btu/h <sup>b</sup>	All	Split System	11.0 SEER	
Air cooled (cooling mode)	≥ 65,000 Btu/h and < 135,000 Btu/h	Electric Resistance (or None)	Split System and Single Package	11.0 EER 12.0 IEER	
		All other	Split System and Single Package	10.8 EER 11.8 IEER	
	≥ 135,000 Btu/h and < 240,000 Btu/h	Electric Resistance (or None)	Split System and Single Package	10.6 EER 11.6 IEER	
		All other	Split System and Single Package	10.4 EER 11.4 IEER	
	≥ 240,000 Btu/h	Electric Resistance (or None)	Split System and Single Package	9.5 EER 10.6 IEER	
		All other	Split System and Single Package	9.3 EER 9.4 IEER	
Water to Air: Water Loop (cooling mode)	< 17,000 Btu/h	All	86°F entering water	12.2 EER	ISO 13256-1
	≥ 17,000 Btu/h and < 65,000 Btu/h	All	86°F entering water	13.0 EER	
	≥ 65,000 Btu/h and < 135,000 Btu/h	All	86°F entering water	13.0 EER	
Water to Air: Ground Water (cooling mode)	< 135,000 Btu/h	All	59°F entering water	18.0 EER	ISO 13256-1
Brine to Air: Ground Loop (cooling mode)	< 135,000 Btu/h	All	77°F entering water	14.1 EER	ISO 13256-1
Water to Water: Water Loop (cooling mode)	< 135,000 Btu/h	All	86°F entering water	10.6 EER	ISO 13256-2
Water to Water: Ground Water (cooling mode)	< 135,000 Btu/h	All	59°F entering water	16.3 EER	
Brine to Water: Ground Loop (cooling mode)	< 135,000 Btu/h	All	77°F entering fluid	12.1 EER	

(Table 2 Continued)

Air cooled (heating mode)	< 65,000 Btu/h <sup>b</sup>	—	Split System	8.2 HSPF	AHRI 210/240
		—	Single Package	8.0 HSPF	
Through-the-wall, (air cooled, heating mode)	≤ 30,000 Btu/h <sup>b</sup> (cooling capacity)	—	Split System	7.4 HSPF	
		—	Single Package	7.4 HSPF	
Small-duct high velocity (air cooled, heating mode)	< 65,000 Btu/h <sup>b</sup>	—	Split System	6.8 HSPF	
Air cooled (heating mode)	≥ 65,000 Btu/h and < 135,000 Btu/h (cooling capacity)	—	47°F db/43°F wb outdoor air	3.3 COP	
			17°Fdb/15°F wb outdoor air	2.25 COP	
	≥ 135,000 Btu/h (cooling capacity)	—	47°F db/43°F wb outdoor air	3.2 COP	
			17°Fdb/15°F wb outdoor air	2.05 COP	
Water to Air: Water Loop (heating mode)	< 135,000 Btu/h (cooling capacity)	—	68°F entering water	4.3 COP	ISO 13256-1
Water to Air: Ground Water (heating mode)	< 135,000 Btu/h (cooling capacity)	—	50°F entering water	3.7 COP	
Brine to Air: Ground Loop (heating mode)	< 135,000 Btu/h (cooling capacity)	—	32°F entering fluid	3.2 COP	
Water to Water: Water Loop (heating mode)	< 135,000 Btu/h (cooling capacity)	—	68°F entering water	3.7 COP	ISO 13256-2
Water to Water: Ground Water (heating mode)	< 135,000 Btu/h (cooling capacity)	—	50°F entering water	3.1 COP	
Brine to Water: Ground Loop (heating mode)	< 135,000 Btu/h (cooling capacity)	—	32°F entering fluid	2.5 COP	

For SI: 1 British thermal unit per hour = 0.2931 W, °C = [(°F) - 32]/1.8.

- a. Chapter 6 contains a complete specification of the referenced test procedure, including the reference year version of the test procedure.
- b. Single-phase, air-cooled heat pumps less than 65,000 Btu/h are regulated by NAECA. SEER and HSPF values are those set by NAECA.

**Table 3: IECC 2018 Electric Chillers, Air-Cooled and Water-Cooled Minimum Efficiency Requirements**

TABLE C403.3.2(7)  
WATER CHILLING PACKAGES — EFFICIENCY REQUIREMENTS<sup>a, b, d</sup>

EQUIPMENT TYPE	SIZE CATEGORY	UNITS	BEFORE 1/1/2015		AS OF 1/1/2015		TEST PROCEDURE <sup>c</sup>	
			Path A	Path B	Path A	Path B		
Air-cooled chillers	< 150 Tons	EER (Btu/W)	≥ 9.562 FL	NA <sup>c</sup>	≥ 10.100 FL	≥ 9.700 FL	AHRI 550/590	
			≥ 12.500 IPLV		≥ 13.700 IPLV	≥ 15.800 IPLV		
	≥ 150 Tons	≥ 9.562 FL	NA <sup>c</sup>	≥ 10.100 FL	≥ 9.700 FL			
		≥ 12.500 IPLV		≥ 14.000 IPLV	≥ 16.100 IPLV			
Air cooled without condenser, electrically operated	All capacities	EER (Btu/W)	Air-cooled chillers without condenser shall be rated with matching condensers and complying with air-cooled chiller efficiency requirements.					
Water cooled, electrically operated positive displacement	< 75 Tons	kW/ton	≤ 0.780 FL	≤ 0.800 FL	≤ 0.750 FL	≤ 0.780 FL		AHRI 550/590
			≤ 0.630 IPLV	≤ 0.600 IPLV	≤ 0.600 IPLV	≤ 0.500 IPLV		
	≥ 75 tons and < 150 tons		≤ 0.775 FL	≤ 0.790 FL	≤ 0.720 FL	≤ 0.750 FL		
			≤ 0.615 IPLV	≤ 0.586 IPLV	≤ 0.560 IPLV	≤ 0.490 IPLV		
	≥ 150 tons and < 300 tons		≥ 0.680 FL	≥ 0.718 FL	≥ 0.660 FL	≥ 0.680 FL		
			≥ 0.580 IPLV	≥ 0.540 IPLV	≥ 0.540 IPLV	≥ 0.440 IPLV		
	≥ 300 tons and < 600 tons		≤ 0.620 FL	≤ 0.639 FL	≤ 0.610 FL	≤ 0.625 FL		
			≤ 0.540 IPLV	≤ 0.490 IPLV	≤ 0.520 IPLV	≤ 0.410 IPLV		
≥ 600 tons	≤ 0.620 FL	≤ 0.639 FL	≤ 0.560 FL	≤ 0.585 FL				
	≤ 0.540 IPLV	≤ 0.490 IPLV	≤ 0.500 IPLV	≤ 0.380 IPLV				
Water cooled, electrically operated centrifugal	< 150 Tons	kW/ton	≤ 0.634 FL	≤ 0.639 FL	≤ 0.610 FL	≤ 0.695 FL	AHRI 560	
			≤ 0.596 IPLV	≤ 0.450 IPLV	≤ 0.550 IPLV	≤ 0.440 IPLV		
	≥ 150 tons and < 300 tons		≤ 0.634 FL	≤ 0.639 FL	≤ 0.610 FL	≤ 0.635 FL		
			≤ 0.596 IPLV	≤ 0.450 IPLV	≤ 0.550 IPLV	≤ 0.400 IPLV		
	≥ 300 tons and < 400 tons		≤ 0.576 FL	≤ 0.600 FL	≤ 0.560 FL	≤ 0.595 FL		
			≤ 0.549 IPLV	≤ 0.400 IPLV	≤ 0.520 IPLV	≤ 0.390 IPLV		
	≥ 400 tons and < 600 tons		≤ 0.576 FL	≤ 0.600 FL	≤ 0.560 FL	≤ 0.585 FL		
			≤ 0.549 IPLV	≤ 0.400 IPLV	≤ 0.500 IPLV	≤ 0.380 IPLV		
≥ 600 Tons	≤ 0.570 FL	≤ 0.590 FL	≤ 0.560 FL	≤ 0.585 FL				
	≤ 0.539 IPLV	≤ 0.400 IPLV	≤ 0.500 IPLV	≤ 0.380 IPLV				
Air cooled, absorption, single effect	All capacities	COP	≥ 0.600 FL	NA <sup>c</sup>	≥ 0.600 FL	NA <sup>c</sup>	AHRI 560	
Water cooled absorption, single effect	All capacities	COP	≥ 0.700 FL	NA <sup>c</sup>	≥ 0.700 FL	NA <sup>c</sup>		
Absorption, double effect, indirect fired	All capacities	COP	≥ 1.000 FL	NA <sup>c</sup>	≥ 1.000 FL	NA <sup>c</sup>		
			≥ 1.050 IPLV		≥ 1.050 IPLV			
Absorption double effect direct fired	All capacities	COP	≥ 1.000 FL	NA <sup>c</sup>	≥ 1.000 FL	NA <sup>c</sup>		
			≥ 1.000 IPLV		≥ 1.050 IPLV			



Note: Code of Federal Regulations for gas-fired hot water boilers (10 CFR 432I(3)):require:

<300,000 Btu/hr hot water boilers to be 84% AFUE, and

<300,000 Btu/hr steam boilers to be 82% AFUE

See **Table 4** below for all other minimum efficiencies.

**Table 4: IECC 2018 Boiler Minimum Efficiency Requirements**

TABLE C403.3.2(5)  
MINIMUM EFFICIENCY REQUIREMENTS: GAS- AND OIL-FIRED BOILERS

EQUIPMENT TYPE <sup>a</sup>	SUBCATEGORY OR RATING CONDITION	SIZE CATEGORY (INPUT)	MINIMUM EFFICIENCY <sup>d, e</sup>	TEST PROCEDURE
Boilers, hot water	Gas-fired	< 300,000 Btu/h <sup>f, g</sup>	<del>82% AFUE</del>	10 CFR Part 430
		≥ 300,000 Btu/h and ≤ 2,500,000 Btu/h <sup>b</sup>	80% E <sub>t</sub>	10 CFR Part 431
		> 2,500,000 Btu/h <sup>a</sup>	82% E <sub>c</sub>	
	Oil-fired <sup>c</sup>	< 300,000 Btu/h <sup>a</sup>	84% AFUE	10 CFR Part 430
		≥ 300,000 Btu/h and ≤ 2,500,000 Btu/h <sup>b</sup>	82% E <sub>t</sub>	10 CFR Part 431
		> 2,500,000 Btu/h <sup>a</sup>	84% E <sub>c</sub>	
Boilers, steam	Gas-fired	< 300,000 Btu/h <sup>f</sup>	<del>80% AFUE</del>	10 CFR Part 430
	Gas-fired- all, except natural draft	≥ 300,000 Btu/h and ≤ 2,500,000 Btu/h <sup>b</sup>	79% E <sub>t</sub>	10 CFR Part 431
		> 2,500,000 Btu/h <sup>a</sup>	79% E <sub>t</sub>	
	Gas-fired-natural draft	≥ 300,000 Btu/h and ≤ 2,500,000 Btu/h <sup>b</sup>	77% E <sub>t</sub>	
		> 2,500,000 Btu/h <sup>a</sup>	77% E <sub>t</sub>	
	Oil-fired <sup>c</sup>	< 300,000 Btu/h	82% AFUE	10 CFR Part 430
		≥ 300,000 Btu/h and ≤ 2,500,000 Btu/h <sup>b</sup>	81% E <sub>t</sub>	10 CFR Part 431
		> 2,500,000 Btu/h <sup>a</sup>	81% E <sub>t</sub>	

**Table 5: IECC 2018 Warm-Air Furnace Minimum Efficiency Requirements**

TABLE C403.3.2(4)  
WARM-AIR FURNACES AND COMBINATION WARM-AIR FURNACES/AIR-CONDITIONING UNITS, WARM-AIR DUCT FURNACES AND UNIT HEATERS, MINIMUM EFFICIENCY REQUIREMENTS

EQUIPMENT TYPE	SIZE CATEGORY (INPUT)	SUBCATEGORY OR RATING CONDITION	MINIMUM EFFICIENCY <sup>d, e</sup>	TEST PROCEDURE <sup>a</sup>
Warm-air furnaces, gas fired	< 225,000 Btu/h	—	80% AFUE or 80%E <sub>t</sub>	DOE 10 CFR Part 430 or ANSI Z21.47
	≥ 225,000 Btu/h	Maximum capacity <sup>c</sup>	80%E <sub>t</sub> <sup>f</sup>	ANSI Z21.47
Warm-air furnaces, oil fired	< 225,000 Btu/h	—	83% AFUE or 80%E <sub>t</sub>	DOE 10 CFR Part 430 or UL 727
	≥ 225,000 Btu/h	Maximum capacity <sup>b</sup>	81%E <sub>t</sub> <sup>g</sup>	UL 727
Warm-air duct furnaces, gas fired	All capacities	Maximum capacity <sup>b</sup>	80%E <sub>c</sub>	ANSI Z83.8
Warm-air unit heaters, gas fired	All capacities	Maximum capacity <sup>b</sup>	80%E <sub>c</sub>	ANSI Z83.8
Warm-air unit heaters, oil fired	All capacities	Maximum capacity <sup>b</sup>	80%E <sub>c</sub>	UL 731

**Table 6: IECC 2018 Water Heater Minimum Efficiency Requirements**

TABLE C404.2  
MINIMUM PERFORMANCE OF WATER-HEATING EQUIPMENT

EQUIPMENT TYPE	SIZE CATEGORY (input)	SUBCATEGORY OR RATING CONDITION	PERFORMANCE REQUIRED <sup>a, b</sup>	TEST PROCEDURE
Water heaters, electric	≤ 12 kW <sup>d</sup>	Tabletop <sup>e</sup> , ≥ 20 gallons and ≤ 120 gallons	0.93 - 0.00132V, EF	DOE 10 CFR Part 430
		Resistance ≥ 20 gallons and ≤ 55 gallons	0.960 - 0.0003V, EF	
		Grid-enabled <sup>f</sup> > 75 gallons and ≤ 120 gallons	1.061 - 0.00168V, EF	
	> 12 kW	Resistance	(0.3 + 27/V <sub>m</sub> ), %/h	ANSI Z21.10.3
	≤ 24 amps and ≤ 250 volts	Heat pump > 55 gallons and ≤ 120 gallons	2.057 - 0.00113V, EF	DOE 10 CFR Part 430
Storage water heaters, gas	≤ 75,000 Btu/h	≥ 20 gallons and > 55 gallons	0.675 - 0.0015V, EF	DOE 10 CFR Part 430
		> 55 gallons and ≤ 100 gallons	0.8012 - 0.00078V, EF	
	> 75,000 Btu/h and ≤ 155,000 Btu/h	< 4,000 Btu/h/gal		ANSI Z21.10.3
		> 155,000 Btu/h	< 4,000 Btu/h/gal	
Instantaneous water heaters, gas	> 50,000 Btu/h and < 200,000 Btu/h <sup>c</sup>	≥ 4,000 (Btu/h)/gal and < 2 gal	0.82 - 0.00 19V, EF	DOE 10 CFR Part 430
	≥ 200,000 Btu/h	≥ 4,000 Btu/h/gal and < 10 gal	80% E <sub>t</sub>	ANSI Z21.10.3
	≥ 200,000 Btu/h	≥ 4,000 Btu/h/gal and ≥ 10 gal	80% E <sub>t</sub>	

**Table 7: IECC 2021 Air-Source Heat Pumps Minimum Efficiency Requirements**

TABLE C403.3.2(2)  
ELECTRICALLY OPERATED AIR-COOLED UNITARY HEAT PUMPS—MINIMUM EFFICIENCY REQUIREMENTS<sup>a, d</sup>

EQUIPMENT TYPE	SIZE CATEGORY	HEADING SECTION TYPE	SUBCATEGORY OR RATING CONDITION	MINIMUM EFFICIENCY	TEST PROCEDURE <sup>e</sup>
Air cooled (cooling mode)	< 66,000 Btu/h	All	Split system, three phase and applications outside US single phase <sup>b</sup>	14.0 SEER before 1/1/2023 14.3 SEER2 after 1/1/2023	AHRI 210/240—2017 before 1/1/2023 AHRI 210/240—2023 after 1/1/2023
			Single package, three phase and applications outside US single phase <sup>b</sup>	14.0 SEER before 1/1/2023 13.4 SEER2 after 1/1/2023	
Space constrained, air cooled (cooling mode)	≤ 30,000 Btu/h	All	Split system, three phase and applications outside US single phase <sup>b</sup>	12.0 SEER before 1/1/2023 11.7 SEER2 after 1/1/2023	AHRI 210/240—2017 before 1/1/2023 AHRI 210/240—2023 after 1/1/2023
			Single package, three phase and applications outside US single phase <sup>b</sup>	12.0 SEER before 1/1/2023 11.7 SEER2 after 1/1/2023	
Single duct, high velocity, air cooled (cooling mode)	< 65,000	All	Split system, three phase and applications outside US single phase <sup>b</sup>	12.0 SEER before 1/1/2023 12.0 SEER2 after 1/1/2023	AHRI 210/240—2017 before 1/1/2023 AHRI 210/240—2023 after 1/1/2023
Air cooled (cooling mode)	≥ 65,000 Btu/h and < 135,000 Btu/h	Electric resistance (or none)	Split system and single package	11.0 EER 12.2 IEER before 1/1/2023 14.1 IEER after 1/1/2023	AHRI 340/360
		All other		10.8 EER 12.0 IEER before 1/1/2023 13.9 IEER after 1/1/2023	
	≥ 135,000 Btu/h and < 240,000 Btu/h	Electric resistance (or none)		10.6 EER 11.6 IEER before 1/1/2023 13.5 IEER after 1/1/2023	
		All other		10.4 EER 11.4 IEER before 1/1/2023 13.3 IEER after 1/1/2023	
	≥ 240,000 Btu/h	Electric resistance (or none)		9.5 EER 10.6 IEER before 1/1/2023 12.5 IEER after 1/1/2023	
		All other		9.3 EER 10.4 IEER before 1/1/2023 12.3 IEER after 1/1/2023	
Air cooled (heating mode)	< 65,000 Btu/h	All	Split system, three phase and applications outside US single phase <sup>b</sup>	8.2 HSPF before 1/1/2023 7.5 HSPF2 after 1/1/2023	AHRI 210/240—2017 before 1/1/2023 AHRI 210/240—2023 after 1/1/2023
			Single package, three phase and applications outside US single phase <sup>b</sup>	8.0 HSPF before 1/1/2023 6.7 HSPF2 after 1/1/2023	

(Table 7 Continued)

TABLE C403.3.2(2)—continued  
ELECTRICALLY OPERATED AIR-COOLED UNITARY HEAT PUMPS—MINIMUM EFFICIENCY REQUIREMENTS<sup>a, d</sup>

EQUIPMENT TYPE	SIZE CATEGORY	HEADING SECTION TYPE	SUBCATEGORY OR RATING CONDITION	MINIMUM EFFICIENCY	TEST PROCEDURE <sup>e</sup>
Space constrained, air cooled (heating mode)	≤ 30,000 Btu/h	All	Split system, three phase and applications outside US single phase <sup>b</sup>	7.4 HSPF before 1/1/2023 6.3 HSPF2 after 1/1/2023	AHRI 210/240—2017 before 1/1/2023 AHRI 210/240—2023 after 1/1/2023
			Single package, three phase and applications outside US single phase <sup>b</sup>	7.4 HSPF before 1/1/2023 6.3 HSPF2 after 1/1/2023	
Small duct, high velocity, air cooled (heating mode)	< 65,000 Btu/h	All	Split system, three phase and applications outside US single phase <sup>b</sup>	7.2 HSPF before 1/1/2023 6.1 HSPF2 after 1/1/2023	AHRI 210/240—2017 before 1/1/2023 AHRI 210/240—2023 after 1/1/2023
Air cooled (heating mode)	≥ 65,000 Btu/h and < 135,000 Btu/h (cooling capacity)	All	47°F db/43°F wb outdoor air	3.30 COP <sub>H</sub> before 1/1/2023 3.40 COP <sub>H</sub> after 1/1/2023	AHRI 340/360
			17°F db/15°F wb outdoor air	2.25 COP <sub>H</sub>	
	≥ 135,000 Btu/h and < 240,000 Btu/h (cooling capacity)		47°F db/43°F wb outdoor air	3.20 COP <sub>H</sub> before 1/1/2023 3.30 SOP <sub>H</sub> after 1/1/2023	
			17°F db/15°F wb outdoor air	2.05 COP <sub>H</sub>	
	≥ 240,000 Btu/h (cooling capacity)		47°F db/43°F wb outdoor air	3.20 COP <sub>H</sub>	
			17°F db/15°F wb outdoor air	2.05 COP <sub>H</sub>	

**Table 8: IECC 2021 Electric Chillers, Air-Cooled and Water-Cooled Minimum Efficiency Requirements**

**TABLE C403.3.2(3)**  
**WATER-CHILLING PACKAGES—MINIMUM EFFICIENCY REQUIREMENTS<sup>a, b, e, f</sup>**

EQUIPMENT TYPE	SIZE CATEGORY	UNITS	PATH A	PATH B	TEST PROCEDURE <sup>e</sup>
Air cooled chillers	< 150 tons	EER (Btu/Wh)	≥ 10.100 FL	≥ 9.700 FL	AHRI 550/590
			≥ 13.700 IPLV.IP	≥ 15.800 IPLV.IP	
	≥ 150 tons		≥ 10.100 FL	≥ 9.700FL	
			≥ 14.000 IPLV.IP	≥ 16.100 IPLV.IP	
Air cooled without condenser, electrically operated	All capacities	EER (Btu/Wh)	Air-cooled chillers without condenser must be rated with matching condensers and comply with air-cooled chiller efficiency requirements		AHRI 550/590
Water cooled, electrically operated positive displacement	< 75 tons	kW/ton	≤ 0.750 FL	≤ 0.780 FL	AHRI 550/590
	≥ 75 tons and < 150 tons		≤ 0.600 IPLV.IP	≤ 0.500 IPLV.IP	
			≤ 0.720 FL	≤ 0.750 FL	
	≥ 150 tons and < 300 tons		≤ 0.560 IPLV.IP	≤ 0.490 IPLV.IP	
			≤ 0.660 FL	≤ 0.680 FL	
	≥ 300 tons and < 600 tons		≤ 0.540 IPLV.IP	≤ 0.440 IPLV.IP	
			≤ 0.610 FL	≤ 0.625 FL	
	≥ 600 tons		≤ 0.520 IPLV.IP	≤ 0.410 IPLV.IP	
≤ 0.560 FL		≤ 0.585 FL			
Water cooled, electrically operated centrifugal	< 150 tons	kW/ton	≤ 0.610 FL	≤ 0.695 FL	AHRI 550/590
			≤ 0.550 IPLV.IP	≤ 0.440 IPLV.IP	
	≥ 300 tons and < 400 tons		≤ 0.610 FL	≤ 0.635 FL	
			≤ 0.550 IPLV.IP	≤ 0.400 IPLV.IP	
	≥ 400 tons and < 600 tons		≤ 0.560 FL	≤ 0.595 FL	
			≤ 0.520 IPLV.IP	≤ 0.390 IPLV.IP	
	≥ 600 tons		≤ 0.560 FL	≤ 0.585 FL	
			≤ 0.500 IPLV.IP	≤ 0.380 IPLV.IP	
	≤ 0.560 FL		≤ 0.585 FL		
	≤ 0.500 IPLV.IP		≤ 0.380 IPLV.IP		
Air cooled absorption, single effect	All capacities	COP (W/W)	≥ 0.600 FL	NA <sup>d</sup>	AHRI 560
Water cooled absorption, single effect	All capacities	COP (W/W)	≥ 0.700 FL	NA <sup>d</sup>	AHRI 560
Absorption double effect, indirect fired	All capacities	COP (W/W)	≥ 1.000 FL	NA <sup>d</sup>	AHRI 560
			≥ 0.150 IPLV.IP		
Absorption double effect, direct fired	All capacities	COP (W/W)	≥ 1.000 FL	NA <sup>d</sup>	AHRI 560
			≥ 1.000 IPLV		

- a. Chapter 6 contains a complete specification of the referenced standards, which include test procedures, including the reference year version of the test procedure.
- b. The requirements for centrifugal chillers shall be adjusted for nonstandard rating conditions per Section C403.3.2.1 and are applicable only for the range of conditions listed there. The requirements for air-cooled, water-cooled positive displacement and absorption chillers are at standard rating conditions defined in the reference test procedure.
- c. Both the full-load and IPLV.IP requirements must be met or exceeded to comply with this standard. When there is a Path B, compliance can be with either Path A or Path B for any application.
- d. NA means the requirements are not applicable for Path B, and only Path A can be used for compliance.
- e. FL is the full-load performance requirements, and IPLV.IP is for the part-load performance requirements.
- f. This table is a replica of ASHRAE 90.1 Table 6.8.1-3 Water-Chilling Packages—Minimum Efficiency Requirements.

Note: Code of Federal Regulations for gas-fired hot water boilers (10 CFR 432I(3)) requires:

<300,000 Btu/hr hot water boilers to be 84% AFUE, and

<300,000 Btu/hr steam boilers to be 82% AFUE

See Table 9 below for all other minimum efficiencies.

**Table 9: IECC 2021 Boiler Minimum Efficiency Requirements**

TABLE C403.3.2(6)  
GAS- AND OIL-FIRED BOILERS—MINIMUM EFFICIENCY REQUIREMENTS<sup>1</sup>

EQUIPMENT TYPE <sup>a</sup>	SUBCATEGORY OR RATING CONDITION	SIZE CATEGORY (INPUT)	MINIMUM EFFICIENCY	EFFICIENCY AS OF 3/2/2022	TEST PROCEDURE <sup>a</sup>
Boilers, hot water	Gas fired	< 300,000 Btu/h <sup>e, b</sup> for applications outside US	82% AFUE	82% AFUE	DOE 10 CFR 430 Appendix N
		≥ 300,000 Btu/h and ≤ 2,500,000 Btu/h <sup>a</sup>	80% $E_t^d$	80% $E_t^d$	DOE 10 CFR 431.86
		> 2,500,000 Btu/h <sup>b</sup>	82% $E_c^c$	82% $E_c^c$	
	Oil fired <sup>f</sup>	< 300,000 Btu/h <sup>e, b</sup> for applications outside US	84% AFUE	84% AFUE	DOE 10 CFR 430 Appendix N
		≥ 300,000 Btu/h and ≤ 2,500,000 Btu/h <sup>a</sup>	82% $E_t^d$	82% $E_t^d$	DOE 10 CFR 431.86
		> 2,500,000 Btu/h <sup>b</sup>	84% $E_c^c$	84% $E_c^c$	
Boilers, steam	Gas fired	< 300,000 Btu/h <sup>e</sup> for applications outside US	80% AFUE	80% AFUE	DOE 10 CFR 430 Appendix N
	Gas fired—all, except natural draft	≥ 300,000 Btu/h and ≤ 2,500,000 Btu/h <sup>a</sup>	79% $E_t^d$	79% $E_t^d$	DOE 10 CFR 431.86
		> 2,500,000 Btu/h <sup>b</sup>	79% $E_t^d$	79% $E_t^d$	
	Gas fired—natural draft	≥ 300,000 Btu/h and ≤ 2,500,000 Btu/h <sup>a</sup>	77% $E_t^d$	79% $E_t^d$	
		> 2,500,000 Btu/h <sup>b</sup>	77% $E_t^d$	79% $E_t^d$	
	Oil fired <sup>f</sup>	< 300,000 Btu/h <sup>e</sup> for applications outside US	82% AFUE	82% AFUE	DOE 10 CFR 430 Appendix N
		≥ 300,000 Btu/h and ≤ 2,500,000 Btu/h <sup>a</sup>	81% $E_t^d$	81% $E_t^d$	DOE 10 CFR 431.86
		> 2,500,000 Btu/h <sup>b</sup>	81% $E_t^d$	81% $E_t^d$	

**Table 10: IECC 2021 Warm-Air Furnace Minimum Efficiency Requirements**

TABLE C403.3.2(5)  
 WARM-AIR FURNACES AND COMBINATION WARM-AIR FURNACES/AIR-CONDITIONING UNITS,  
 WARM-AIR DUCT FURNACES AND UNIT HEATERS—MINIMUM EFFICIENCY REQUIREMENTS<sup>a</sup>

EQUIPMENT TYPE	SIZE CATEGORY (INPUT)	SUBCATEGORY OR RATING CONDITION	MINIMUM EFFICIENCY	TEST PROCEDURE <sup>a</sup>
Warm-air furnace, gas fired for application outside the US	< 225,000 Btu/h	Maximum capacity <sup>c</sup>	80% AFUE (nonweatherized) or 81% AFUE (weatherized) or 80% $E_t^{b,d}$	DOE 10 CFR 430 Appendix N or Section 2.39, Thermal Efficiency, ANSI Z21.47
Warm-air furnace, gas fired	< 225,000 Btu/h	Maximum capacity <sup>c</sup>	80% $E_t^{b,d}$ before 1/1/2023 81% $E_t^d$ after 1/1/2023	Section 2.39, Thermal Efficiency, ANSI Z21.47
Warm-air furnace, oil fired for application outside the US	< 225,000 Btu/h	Maximum capacity <sup>c</sup>	83% AFUE (nonweatherized) or 78% AFUE (weatherized) or 80% $E_t^{b,d}$	DOE 10 CFR 430 Appendix N or Section 42, Combustion, UL 727
Warm-air furnace, oil fired	< 225,000 Btu/h	Maximum capacity <sup>c</sup>	80% $E_t$ before 1/1/2023 82% $E_t^d$ after 1/1/2023	Section 42, Combustion, UL 727
Electric furnaces for applications outside the US	< 225,000 Btu/h	All	96% AFUE	DOE 10 CFR 430 Appendix N
Warm-air duct furnaces, gas fired	All capacities	Maximum capacity <sup>c</sup>	80% $E_c^e$	Section 2.10, Efficiency, ANSI Z83.8
Warm-air unit heaters, gas fired	All capacities	Maximum capacity <sup>c</sup>	80% $E_c^{e,f}$	Section 2.10, Efficiency, ANSI Z83.8
Warm-air unit heaters, oil fired	All capacities	Maximum capacity <sup>c</sup>	80% $E_c^{e,f}$	Section 40, Combustion, UL 731



**Table 11: IECC 2021 Water Heater Minimum Efficiency Requirements**

TABLE C404.2  
MINIMUM PERFORMANCE OF WATER-HEATING EQUIPMENT

EQUIPMENT TYPE	SIZE CATEGORY (input)	SUBCATEGORY OR RATING CONDITION	PERFORMANCE REQUIRED <sup>a, b</sup>	TEST PROCEDURE
Water heaters, electric	≤ 12 kW <sup>d</sup>	Tabletop <sup>e</sup> , ≥ 20 gallons and ≤ 120 gallons	0.93 – 0.00132V, EF	DOE 10 CFR Part 430
		Resistance ≥ 20 gallons and ≤ 55 gallons	0.960 – 0.0003V, EF	
		Grid-enabled <sup>f</sup> > 75 gallons and ≤ 120 gallons	1.061 – 0.00168V, EF	
	> 12 kW	Resistance	(0.3 + 27/V <sub>m</sub> ), %/h	ANSI Z21.10.3
	≤ 24 amps and ≤ 250 volts	Heat pump > 55 gallons and ≤ 120 gallons	2.057 – 0.00113V, EF	DOE 10 CFR Part 430
Storage water heaters, gas	≤ 75,000 Btu/h	≥ 20 gallons and ≤ 55 gallons	0.675 – 0.0015V, EF	DOE 10 CFR Part 430
		> 55 gallons and ≤ 100 gallons	0.8012 – 0.00078V, EF	
	> 75,000 Btu/h and ≤ 155,000 Btu/h	< 4,000 Btu/h/gal	80% E <sub>t</sub> (Q/800 + 110.√V̇)SL, Btu/h	ANSI Z21.10.3
> 155,000 Btu/h	< 4,000 Btu/h/gal	80% E <sub>t</sub> (Q/800 + 110.√V̇)SL, Btu/h		
Instantaneous water heaters, gas	> 50,000 Btu/h and < 200,000 Btu/h <sup>e</sup>	≥ 4,000 Btu/h/gal and < 2 gal	0.82 – 0.0019V, EF	DOE 10 CFR Part 430
	≥ 200,000 Btu/h	≥ 4,000 Btu/h/gal and < 10 gal	80% E <sub>t</sub>	ANSI Z21.10.3
	≥ 200,000 Btu/h	≥ 4,000 Btu/h/gal and ≥ 10 gal	80% E <sub>t</sub> (Q/800 + 110.√V̇)SL, Btu/h	
Storage water heaters, oil	≤ 105,000 Btu/h	≥ 20 gal and ≤ 50 gallons	0.68 – 0.0019V, EF	DOE 10 CFR Part 430
	≥ 105,000 Btu/h	< 4,000 Btu/h/gal	80% E <sub>t</sub> (Q/800 + 110.√V̇)SL, Btu/h	ANSI Z21.10.3
Instantaneous water heaters, oil	≤ 210,000 Btu/h	≥ 4,000 Btu/h/gal and < 2 gal	0.59 – 0.0019V, EF	DOE 10 CFR Part 430
	> 210,000 Btu/h	≥ 4,000 Btu/h/gal and < 10 gal	80% E <sub>t</sub>	ANSI Z21.10.3
	> 210,000 Btu/h	≥ 4,000 Btu/h/gal and ≥ 10 gal	78% E <sub>t</sub> (Q/800 + 110.√V̇)SL, Btu/h	
Hot water supply boilers, gas and oil	≥ 300,000 Btu/h and < 12,500,000 Btu/h	≥ 4,000 Btu/h/gal and < 10 gal	80% E <sub>t</sub>	ANSI Z21.10.3
Hot water supply boilers, gas	≥ 300,000 Btu/h and < 12,500,000 Btu/h	≥ 4,000 Btu/h/gal and ≥ 10 gal	80% E <sub>t</sub> (Q/800 + 110.√V̇)SL, Btu/h	
Hot water supply boilers, oil	> 300,000 Btu/h and < 12,500,000 Btu/h	> 4,000 Btu/h/gal and > 10 gal	78% E <sub>t</sub> (Q/800 + 110.√V̇)SL, Btu/h	

**Time of Sale:** The baseline for this measure is a new replacement unit of the same system type as the existing unit, meeting the minimum efficiencies provided above.

**Early Replacement / Retrofit:** The baseline for this measure is the efficiency of the *existing* heating, cooling, and hot water equipment for the assumed remaining useful life of the existing unit, and a new baseline heating and cooling system for the remainder of the measure life (as provided in tables above).



**DEEMED LIFETIME OF EFFICIENT EQUIPMENT**

The expected measure life of the gas heat pump is assumed to be 15 years for a natural gas heat pump<sup>1050</sup>.

For early replacement, the remaining life of existing equipment is assumed to be 6 years for an air-source heat pump and Central A/C, 6 years for a furnace, and 8 years for boilers and ground source heat pumps.<sup>1051</sup>

**DEEMED MEASURE COST**

New Construction and Time of Sale: Incremental costs of the gas heat pump should be used. This would be the actual installed cost of the heat pump equipment as well as system commissioning costs, minus the assumed installation cost of the baseline equipment.

Early Replacement: The actual installed cost of the gas heat pump should be used. The assumed deferred cost of replacing existing equipment with a new baseline is 1/3 of the incremental cost. This future cost should be discounted to present value using the nominal societal discount rate.

The incremental cost of gas heat pump over various replacement equipment is shown in Table 7<sup>1052</sup>.

**Table 7: Incremental Cost of Commercial Gas Heat Pump**

Incremental Cost (\$/ton)		
Replaced Technologies	Installed Cost (\$/ton)	Incremental GHP Cost (\$/ton)
Rooftop Air Source Heat Pump	1,813	1,987
Ground Source Heat Pump	5,781	- 1,981
Electric Boiler	250	3,550
Natural Gas Furnace	92	3,709
Natural Gas Boiler	594	3,206
Air-cooled Electric Chiller	988	2,813
Water-cooled Electric Chiller	550	3,250
Gas-fired Water Heater	384	3,416
Electric-resistance Water Heater	772	3,028
Gas Heat Pump	3,800	

**Guide to read incremental cost:**

**Example 1:** for a gas boiler and air-cooled electric chiller being replaced with a gas heat pump, the incremental cost will be (Cost of GHP) – (Cost of Natural Gas Boiler + Air-Cooled Electric Chiller) = \$3,800 – (\$594 + \$988) = \$2,218.

**Example 2:** for a gas boiler and gas-fired water heater being replaced with a gas heat pump, the incremental cost will be Cost of GHP – (Cost of Natural Gas Boiler + Gas Fired Water Heater) = \$3,800 – (\$594+\$384) = \$2,822.

**LOADSHAPE**

Depending on the baseline conditions, the appropriate loadshapes will be a combination of some, but not all, of the loadshapes below. Note for the purpose of cost-effectiveness screening for a fuel switching scenario, the cooling therm increase, and heating therm decrease should be calculated separately such as the appropriate loadshape (i.e.,

<sup>1050</sup> U.S. Energy Information Administration | Assumptions to the Annual Energy Outlook 2021: Commercial Demand Module: <https://www.eia.gov/outlooks/aeo/assumptions/pdf/commercial.pdf>

<sup>1051</sup> Assumed to be one third of effective useful life of replaced equipment.

<sup>1052</sup> U.S. Energy Information Administration (EIA), Updated Buildings Sector Appliance and Equipment Costs and Efficiencies: <https://www.eia.gov/analysis/studies/buildings/equipcosts/pdf/full.pdf>

Loadshape C04 – Commercial Electric Heating and Loadshape C03 – Commercial Cooling, respectively) can be applied.

Loadshape C02 – Commercial Electric SHW

Loadshape C03 – Commercial Cooling

Loadshape C04 – Commercial Electric Heating (if replacing building with no existing cooling)

Loadshape C05 – Commercial Electric Heating and Cooling

**COINCIDENCE FACTOR**

The summer peak coincidence factor for cooling is provided in two different ways below. The first is used to estimate peak savings during the utility peak hour and is most indicative of actual peak benefits. The second represents the average savings over the defined summer peak period and is presented so that savings can be bid into PJM’s capacity market. Both values provided are based on analysis of Itron eShape data for Missouri, calibrated to Illinois loads, supplied by Ameren.

$$CF_{SSP} = \text{Summer System Peak Coincidence Factor for Commercial Cooling (during system peak hour)}$$

$$= 91.3\%^{1053}$$

$$CF_{PJM} = \text{PJM Summer Peak Coincidence Factor for Commercial Cooling (average during peak period)}$$

$$= 47.8\%^{1054}$$

---

**Algorithm**

---

**CALCULATION OF ENERGY SAVINGS**

**ELECTRIC ENERGY SAVINGS AND FOSSIL FUEL SAVINGS**

**Non-Fuel Switch Measures:**

$$\Delta\text{therms} = \Delta\text{therms}_{SPACE} + \Delta\text{therms}_{SHW}$$

Space Heating Savings

$$\Delta\text{therms}_{SPACE} = \text{EFLH} * \text{Capacity} * ((\text{Efficiency}_{EE} - \text{Efficiency}_{Base}) / \text{Efficiency}_{Base}) / 100,000$$

Where:

EFLH = Equivalent Full Load Hours for heating in Existing Buildings or New Construction are provided in section 4.4 HVAC End Use

Capacity = Nominal Heating Input Capacity Size (Btu/hr) for efficient unit not existing unit  
 = custom gas-fired heat pump input capacity (Btu/hr)

Efficiency<sub>Base</sub> = Baseline Efficiency Rating, dependant on year and boiler type. See Table 4 above

Efficiency<sub>EE</sub> = Rated Commerical Gas Heat Pump space heating efficiency, expressed as a fuel-input only COP<sub>Gas</sub>, for the nominal capacity rating condition

Hot water boiler baseline:

---

<sup>1053</sup> Values taken from established TRM references in section 4.4.44 and based on analysis of Itron eShape data for Missouri, calibrated to Illinois loads, supplied by Ameren. The AC load during the utility’s peak hour is divided by the maximum AC load during the year.

<sup>1054</sup> Values taken from established TRM references in section 4.4.44 and based on analysis of Itron eShape data for Missouri, calibrated to Illinois loads, supplied by Ameren. The average AC load over the PJM peak period (1-5pm M-F, June through August) is divided by the maximum AC load during the year.

Hot Water Boiler Capacity (Btu/hr)	Efficiency
Hot Water < 300,000 <sup>1055</sup>	84% AFUE
300,000 ≤ Hot Water ≤ 2,500,000 <sup>1056</sup>	80% E <sub>T</sub>
2,500,000 < Hot Water <sup>1057</sup>	82% E <sub>C</sub>

**For example**, a 150,000 BTU/hr water boiler meeting COP<sub>Gas</sub> 1.4 is installed in Rockford at a high-rise office building in the year 2022:

$$\begin{aligned} \Delta\text{Therms} &= 2,089 * 150,000 * (1.4 - 0.840) / 0.840 / 100,000 \text{ Btu/Therm} \\ &= 2,089.0 \text{ therms} \end{aligned}$$

**Service Hot Water Savings:**

$$\Delta\text{Therms}_{SHW} = \frac{(T_{out} - T_{in}) * \text{HotWaterUse}_{Gallon} * \gamma_{Water} * 1.0 * \left( \frac{1}{TE_{gasbase}} - \frac{1}{COP_{Eff}} \right)}{100,000}$$

Where:

T<sub>OUT</sub> = Tank temperature  
= 140°F

T<sub>IN</sub> = Incoming water temperature from well or municipal system  
= 54°F <sup>1058</sup>

HotWaterUse<sub>Gallon</sub>  
= Estimated annual hot water consumption (gallons)  
= Actual, if possible to provide reasonable custom estimate. If not, two methodologies are provided to develop an estimate:

1. Consumption per usable storage tank capacity = Capacity \* (Consumption/Cap)

Where:

Capacity = Usable capacity of hot water storage tank in gallons  
= Actual

Consumption/Cap = Estimate of consumption per gallon of usable tank capacity, based on building type: <sup>1059</sup>

Building Type <sup>1060</sup>	Consumption/Cap
Convenience	528
Education	568
Grocery	528
Health	788
Large Office	511

<sup>1055</sup> Code of Federal Regulations, effective January 15, 2021 (10 CFR 432(e)(3)).

<sup>1056</sup> Thermal Efficiency. Code of Federal Regulations, effective March 2, 2012 (10 CFR 431.87).

<sup>1057</sup> Combustion Efficiency. Code of Federal Regulations, effective March 2, 2012 (10 CFR 431.87).

<sup>1058</sup> US DOE Building America Program, Building America Analysis Spreadsheet (for Chicago, IL), Office of Energy Efficiency & Renewable Energy.

<sup>1059</sup> Methodology based on Cadmus analysis. Annual hot water usage in gallons based on CBECS (2012) and RECS (2009) consumption data of East North Central (removed outliers of 1,000 kBtu/h or less) to calculate hot water usage. Annual hot water gallons per tank size gallons based on the tank sizing methodology found in ASHRAE 2011 HVAC Applications. Chapter 50 Service Water Heating. Demand assumptions (gallons per day) for each building type based on ASHRAE Chapter 50 and to LBNL White Paper. LBL-37398 Technology Data Characterizing Water Heating in Commercial Buildings: Application to End Use Forecasting. Assumes hot water heater efficiency of 80%.

<sup>1060</sup> According to CBECS 2012 “Lodging” buildings include Dormitories, Hotels, Motel or Inns and other Lodging and “Nursing” buildings include Assisted Living and Nursing Homes.

Building Type <sup>1060</sup>	Consumption/Cap
Large Retail	528
Lodging	715
Other Commercial	341
Restaurant	622
Small Office	511
Small Retail	528
Warehouse	341
Nursing	672
Multi-Family	894

$$2. \text{ Consumption per unit area by building type} = (\text{Area} / 1000) * \text{Consumption}/1,000\text{ft}^2$$

Where:

Area = Area in ft<sup>2</sup> that is served by SHW boiler  
 = Actual

Consumption/1,000ft<sup>2</sup> = Estimate of SHW consumption per 1,000ft<sup>2</sup> based on building type:<sup>1061</sup>

Building Type <sup>1062</sup>	Consumption/1,000ft <sup>2</sup>
Convenience	4,594
Education	7,285
Grocery	697
Health	24,540
Large Office	1,818
Large Retail	1,354
Lodging	29,548
Other Commercial	3,941
Restaurant	44,439
Small Office	1,540
Small Retail	6,111
Warehouse	1,239
Nursing	30,503
Multi-Family	15,434

$\gamma_{\text{Water}}$  = Specific weight capacity of water (lb/gal) = 8.33 lbs/gal

1 = Specific heat of water (Btu/lb.°F)<sup>1063</sup>

100,000 = Converts Btu to Therms

$TE_{\text{gasbase}}$  = Rated efficiency of baseline water heater (expressed as Uniform Energy Factor (UEF) or Thermal Efficiency as provided below).

<sup>1061</sup> Methodology based on Cadmus analysis. Annual hot water usage in gallons based on CBECS (2012) and RECS (2009) consumption data of East North Central (removed outliers of 1,000 kBtu/h or less) to calculate hot water usage. Annual hot water gallons per tank size gallons based on the tank sizing methodology found in ASHRAE 2011 HVAC Applications. Chapter 50 Service Water Heating. Demand assumptions (gallons per day) for each building type based on ASHRAE Chapter 50 and to LBNL White Paper. LBL-37398 Technology Data Characterizing Water Heating in Commercial Buildings: Application to End Use Forecasting. Assumes hot water heater efficiency of 80%.

<sup>1062</sup> According to CBECS 2012 “Lodging” buildings include Dormitories, Hotels, Motel or Inns and other Lodging and “Nursing” buildings include Assisted Living and Nursing Homes.

<sup>1063</sup> Specific heat is the amount of heat required to change the temperature of a mass by one degree.

$COP_{Eff}$  = Rated efficiency of the commercial gas heat pump as certified expressed as Uniform Energy Factor (UEF) or Coefficient of Performance as provided below.

Note the same draw pattern (very small, low, medium, and high draw) should be used for both baseline and efficient units.

Equipment Type	Sub-Category	Draw Pattern	Federal Standard – Uniform Energy Factor or Thermal Efficiency <sup>1064</sup>
Residential-duty Commercial High-Capacity Storage Gas-Fired Storage Water Heaters >75,000 Btu/h	≤120 gallon tanks	Very small	UEF = 0.2674 – (0.0009 * Rated Storage Volume in Gallons)
		Low	UEF = 0.5362 – (0.0012 * Rated Storage Volume in Gallons)
		Medium	UEF = 0.6002 – (0.0011 * Rated Storage Volume in Gallons)
		High	UEF = 0.6597 – (0.0009 * Rated Storage Volume in Gallons)
Commercial Gas Storage Water Heaters >75,000 Btu/h	>120 gallon tanks	All	80% $E_{thermal}$ , Standby Losses = $(Q / 800 + 110V \text{Rated Storage Volume in Gallons})$
Commercial Gas Storage Water Heaters >155,000 Btu/h		All	
Commercial Gas Instantaneous Water Heaters >200,000 Btu/h	<10 gallon	All	80% $E_{thermal}$
	≥10 gallon	All	78% $E_{thermal}$

Draw patterns are based on first hour rating (gallons) for storage tanks and maximum flow (GPM) for instantaneous as shown below:<sup>1065</sup>

Storage Water Heater Draw Pattern	
Draw Pattern	First Hour Rating (gallons)
Very Small	≥ 0 and < 18
Low	≥ 18 and < 51
Medium	≥ 51 and < 75
High	≥ 75

Instantaneous Water Heater Draw Pattern	
Draw Pattern	Max GPM
Very Small	≥ 0 and < 1.7
Low	≥ 1.7 and < 2.8
Medium	≥ 2.8 and < 4

**For example**, for a 200,000 Btu/h, 150 gallon, GHP with a COP = 1.4 installed in a 1500 ft<sup>2</sup> restaurant:  
 $\Delta\text{Therms} = ((140 - 54) * ((1,500/1,000) * 44,439) * 8.33 * 0.975 * (1/0.8 - 1/1.4))/100,000$   
 = 249.4 Therms

**Fuel Switch Measures:**

<sup>1064</sup> All Residential sized Federal Standards are from DOE Standard 10 CFR 430, Residential-Duty and Commercial Federal Standard are from DOE Standard 10 CFR 431.

<sup>1065</sup> Definitions provided in 10 CFR 430, Subpart B, Appendix E, Section 5.4.1.

Fuel switching measures must produce positive total annual source fuel savings (i.e., reduction in source Btus) in order to qualify. This is determined as follows (note for early replacement measures the lifetime savings should be calculated by calculating savings for the remaining useful life of the existing equipment and for the remaining measure life):

$$\text{SourceEnergySavings (MMBTUs)} = (\text{ElectricHeatReplaced} - \text{GHPEnergyConsumed}_{\text{Heat}}) + (\text{ElectricCoolingReplaced} - \text{GHPEnergyConsumed}_{\text{Cool}}) + (\text{ElectricWaterHeatReplaced} - \text{GHPEnergyConsumed}_{\text{SHW}})$$

If SourceEnergySavings calculated above is positive, the measure is eligible.

**Electric Space Heating Replaced with Natural Gas Heat Pump**

$$\text{ElectricHeatReplaced [MMBTU}_{\text{source}}] = (\text{kBtu/hr}_{\text{heat}} * \text{EFLH}_{\text{heat}} * (1/\text{COP}_{\text{base}})) * 1000/3412 * (\text{LifetimeH}_{\text{grid}} * (1 + \text{ElectricT\&D}))/ 1,000,000$$

$$\text{GHPEnergyConsumed}_{\text{Heat}} [\text{MMBTU}_{\text{source}}] = ((\text{kBtu/hr}_{\text{heat}} * \text{EFLH}_{\text{heat}} * (1/\text{COP}_{\text{GHP}})) / 1000) * (1 + \text{GasSystemDistributionLoss})$$

Where:

- $\text{kBtu/hr}_{\text{heat}}$  = capacity of the heating equipment in kBtu per hour (1 ton of heating capacity equals 12 kBtu/hr).
- $\text{COP}_{\text{base}}$  = Coefficient of performance of the baseline equipment, or thermal efficiency if applicable, at nominal condition  
 = based on the applicable Code on the date of equipment purchase (if unknown assume current Code). If rating is HSPF,  $\text{COP} = \text{HSPF} / 3.413$
- $\text{EFLH}_{\text{Heat}}$  = Heating Equivalent Full Load Hours  
 = Dependent on building type and Existing Buildings or New Construction, provided in section 4.4 HVAC End Use
- $\text{COP}_{\text{GHP}}$  = Coefficient of performance of the GHP equipment at nominal condition  
 = Actual installed
- $\text{LifetimeH}_{\text{grid}}$  = Average Heat rate of the grid in Btu/kWh over the lifetime of the measure. Used to calculate eligibility  
 = 7,700 BTU/kWh <sup>1066</sup>
- $\text{FirstYearH}_{\text{grid}}$  = Heat rate of the grid in BTU/kWh for first year of the measure. Used to calculate savings for first 6 years of measure life.  
 = 8,600 BTU / kWh <sup>1067</sup>
- $\text{PostAdjH}_{\text{grid}}$  = Heat rate of the grid in BTU/kWh for remaining years of the measure life. Used to calculate savings for remaining years of measure life resulting in approximately equal lifetime savings.

<sup>1066</sup> Determination of the appropriate heat rate values for use in these calculations is complex and contentious. Lifetime grid heat rate was estimated based on review of multiple sources and methodologies, and represents the estimated average marginal grid heat rate over the lifetime of the measure. Note, if legislation is passed that dictates that fuel conversion calculations should be performed at site, the site conversion factor of 3,412 BTU/kWh shall be utilized in place of the grid heat rates presented here for the specified application and timeframe.

<sup>1067</sup> First year heat rate was estimated in 2021, based on review of multiple sources and methodologies, and represents the estimated IL grid marginal heat rate. Note, if legislation is passed that dictates that fuel conversion calculations should be performed at site, the site conversion factor of 3,412 BTU/kWh shall be utilized in place of the grid heat rates presented here for the specified application and timeframe.

	= 7,200 BTU/kWh <sup>1068</sup>
ElectricT&D	= Electric marginal Transmission and Distribution Loss Factor = 10.7% (ComEd) = 11.3% (Ameren)
GasSystemDistributionLoss	= Gas System and Distribution Loss Factor = 0% <sup>1069</sup>

### Electric Cooling Replaced with Natural Gas Heat Pump

$$\text{ElectricCoolingReplaced [MMBTU}_{\text{source}}] = (\text{kBtu/hr}_{\text{cool}} * \text{EFLH}_{\text{cool}} * (1/\text{EER}_{\text{base}})) * (\text{LifetimeH}_{\text{grid}} * (1 + \text{ElectricT\&D}))/ 1,000,000$$

$$\text{GHPEnergy Consumed}_{\text{cool}} [\text{MMBTU}_{\text{source}}] = ((\text{kBtu/hr}_{\text{cool}} * \text{EFLH}_{\text{cool}} * (1/\text{COP}_{\text{GHP}})) / 1000) * (1 + \text{GasSystemDistributionLoss})$$

$\text{kBtu/hr}_{\text{cool}}$  = capacity of the cooling equipment in kBtu per hour (1 ton of cooling capacity equals 12 kBtu/hr).

$\text{EER}_{\text{base}}$  = Energy Efficiency Ratio of the baseline equipment at nominal condition

$\text{EFLH}_{\text{cool}}$  = Equivalent Full Load Hours for cooling in Existing Buildings or New Construction are provided in section 4.4 HVAC End Use.

$\text{COP}_{\text{GHP}}$  = Coefficient of performance of the GHP equipment at nominal condition  
= Actual installed

### Electric Water Heating Replaced with Natural Gas Heat Pump

$$\text{ElectricWaterHeatReplaced [MMBTU}_{\text{source}}] = ((T_{\text{out}} - T_{\text{in}}) * \text{HotWaterUse}_{\text{gallon}} * \gamma_{\text{Water}} * 1.0 * (1/\text{TE}_{\text{elecbase}})) / 3412 * (\text{LifetimeH}_{\text{grid}} * (1 + \text{ElectricT\&D}))/ 1,000,000$$

$$\text{GHPEnergyConsumed}_{\text{SHW}} [\text{MMBTU}_{\text{source}}] = (T_{\text{out}} - T_{\text{in}}) * \text{HotWaterUse}_{\text{gallon}} * \gamma_{\text{Water}} * 1.0 * (1/\text{COP}_{\text{GHP}}) / 1,000,000 * (1 + \text{GasSystemDistributionLoss})$$

\*\*See previous nonfuel switch section for most descriptions

$\text{TE}_{\text{elecbase}}$  = Rated efficiency of baseline water heater expressed as Uniform Energy Factor (UEF) or Thermal Efficiency (TE) or Coefficient of Performance (COP), if not provided for resistance-type electric water heating assume  $\text{TE}_{\text{elec,base}} = 0.98$

$\text{COP}_{\text{GHP}}$  = Coefficient of performance of the GHP equipment  
= Actual installed

<sup>1068</sup> Applying the first year heat rate for 6 years, followed by this  $\text{PostAdjH}_{\text{grid}}$  value for the remaining measure life produces a lifetime savings that is consistent with application of the lifetime heat rate provided. Note, if legislation is passed that dictates that fuel conversion calculations should be performed at site, the site conversion factor of 3,412 BTU/kWh shall be utilized in place of the grid heat rates presented here for the specified application and timeframe.

<sup>1069</sup> The 2021 TAC discussed whether it was appropriate to apply a factor to account for any marginal gas system and distribution losses relating to the gas savings in these equations. The TAC were unable to reach agreement and so this issue will be reviewed again next year. Since this is a new assumption, and likely to be a relatively small value, it was decided to set at 0% for 2022.

$$\text{Total Therm Savings} = \text{SourceEnergySavings} * 10 / (1 + \text{GasSystemDistributionLoss})$$



**Example:**

*[for illustrative purposes, an ElectricT&D of 10.7%, GasSystemDistributionLoss of 1.4% is used]*

A 3,000-squarefoot building with a 120 kBtu/hr output gas heat pump system replacing existing baseline equipment with COP of 1.3 in heating, cooling, and water heating in a Chicagoland public elementary school. The baseline equipment being replaced are all electric heating, cooling, and service hot water heater.

Baseline equipment efficiency: electric air source heating – 2.25 COP; electric air source cooling – 10.8 EER. Electric service hot water heater – 0.98 TE.

**Heating Source MMBTU Savings** = ElectricHeatReplaced - GHPEnergyConsumed<sub>Heat</sub>

$$\begin{aligned} \text{ElectricHeatReplaced [MMBTU}_{\text{source}}] &= (\text{kBtu/hr}_{\text{heat}} * \text{EFLH}_{\text{heat}} * (1/\text{COP}_{\text{base}})) * 1000/3412 * \\ &(\text{LifetimeH}_{\text{grid}} * (1 + \text{ElectricT\&D}))/ 1,000,000 \\ &= (120 * 1603 * (1/2.25)) * 1000/3412 * (7,700 * (1 + 0.107))/1,000,000 \\ &= 213.6 \end{aligned}$$

$$\begin{aligned} \text{GHPEnergyConsumed}_{\text{Heat}} [\text{MMBTU}_{\text{source}}] &= ((\text{kBtu/hr}_{\text{heat}} * \text{EFLH}_{\text{heat}} * (1/\text{COP}_{\text{GHP}})) / 1000) * (1 + \\ &\text{GasSystemDistributionLoss}) \\ &= (120 * 1603 * 1/1.3)/1000 * (1 + 0.014) \\ &= 150.0 \end{aligned}$$

**Cooling Source MMBTU Savings** = ElectricCoolingReplaced- GHPEnergy Consumed<sub>cool</sub>

$$\begin{aligned} \text{ElectricCoolingReplaced [MMBTU}_{\text{source}}] &= (\text{kBtu/hr}_{\text{cool}} * \text{EFLH}_{\text{cool}} * (1/\text{EER}_{\text{base}})) * (\text{LifetimeH}_{\text{grid}} * (1 + \\ &\text{ElectricT\&D}))/ 1,000,000 \\ &= (120 * 837 * 1/10.8) * (7,700 * (1 + 0.107))/1,000,000 \\ &= 79.3 \end{aligned}$$

$$\begin{aligned} \text{GHPEnergy Consumed}_{\text{cool}} [\text{MMBTU}_{\text{source}}] &= ((\text{kBtu/hr}_{\text{cool}} * \text{EFLH}_{\text{cool}} * (1/\text{COP}_{\text{GHP}})) / 1000) * (1 + \\ &\text{GasSystemDistributionLoss}) \\ &= (120 * 837 * 1/1.3) / 1000 * (1 + 0.014) \\ &= 78.3 \end{aligned}$$

**Service Hot Water Heater Source MMBTU Savings** = ElectricWaterHeatReplaced - GHPEnergyConsumed<sub>SHW</sub>

$$\begin{aligned} \text{ElectricWaterHeatReplaced [MMBTU}_{\text{source}}] &= ((\text{T}_{\text{out}}-\text{T}_{\text{in}}) * \text{HotWaterUse}_{\text{gallon}} * \gamma_{\text{Water}} * 1.0 * \\ &(1/\text{TE}_{\text{elecbase}})) / 3412 * (\text{LifetimeH}_{\text{grid}} * (1 + \text{ElectricT\&D}))/ \\ &1,000,000 \\ &= ((140 - 54) * (7285*3) * 8.33 * 1 * (1/0.98)) / 3412 * (7,700 * (1 + \\ &0.107))/1,000,000 \\ &= 39.9 \end{aligned}$$

$$\begin{aligned} \text{GHPEnergyConsumed}_{\text{SHW}} [\text{MMBTU}_{\text{source}}] &= ((\text{T}_{\text{out}}-\text{T}_{\text{in}}) * \text{HotWaterUse}_{\text{gallon}} * \gamma_{\text{Water}} * 1.0 * (1/\text{COP}_{\text{GHP}}) \\ &/ 1,000,000) * (1 + \text{GasSystemDistributionLoss}) \\ &= (((140 - 54) * (7285*3) * 8.33 * 1.0 * (1/1.3))/1,000,000) * (1 + 0.014) \\ &= 12.2 \end{aligned}$$

**Example continued:**

$$\begin{aligned} \text{Total Source MMBTU Savings} &= (213.6 - 150.0) + (79.3 - 78.3) + (39.9 - 12.2) \\ &= 92.3 \end{aligned}$$

$$\begin{aligned} \text{Total Therm Savings} &= 92.3 * 10 / (1 + 0.014) \\ &= 910.3 \text{ Therms} \end{aligned}$$

**SUMMER COINCIDENT PEAK DEMAND SAVINGS**

New Construction / Time of Sale:

$$\Delta kW = (\text{kBtu/hr} * (1/\text{EER}_{\text{base}})) * \text{CF}$$

Early Replacement / Retrofit:

$$\Delta kW = (\text{kBtu/hr} * (1/\text{EER}_{\text{exist}})) * \text{CF}$$

Where:

$\text{EER}_{\text{base}}$  = Energy Efficiency Ratio of the baseline equipment

$\text{EER}_{\text{exist}}$  = Energy Efficiency Ratio of the existing equipment

= Actual, or assume Code base in place at the original time of existing unit installation

$\text{CF}_{\text{SSP}}$  = Summer System Peak Coincidence Factor for Commercial cooling (during system peak hour)

$$= 91.3\%^{1070}$$

$\text{CF}_{\text{PJM}}$  = PJM Summer Peak Coincidence Factor for Commercial cooling (average during peak period)

$$= 47.8\%^{1071}$$

**For example**, a 120 kBtu/hr electric air source cooling with a 10.8 EER replaced with a gas heat pump in Chicago would save:

$$\begin{aligned} \Delta kW_{\text{SSP}} &= (120 * (1 / 10.8)) * 0.913 \\ &= 10.14 \text{ kW} \end{aligned}$$

**FOSSIL FUEL SAVINGS**

Calculation provided together with Electric Energy Savings above.

**WATER AND OTHER NON-ENERGY IMPACT DESCRIPTIONS AND CALCULATION**

N/A

**DEEMED O&M COST ADJUSTMENT CALCULATION**

N/A. The installed cost of gas heat pump includes O&M agreement.

<sup>1070</sup> Based on analysis of Itron eShape data for Missouri, calibrated to Illinois loads, supplied by Ameren. The AC load during the utility's peak hour is divided by the maximum AC load during the year.

<sup>1071</sup>Based on analysis of Itron eShape data for Missouri, calibrated to Illinois loads, supplied by Ameren. The average AC load over the PJM peak period (1-5pm, M-F, June through August) is divided by the maximum AC load during the year.

**COST EFFECTIVENESS SCREENING AND LOAD REDUCTION FORECASTING WHEN FUEL SWITCHING**

This measure can involve fuel switching from electric to gas.

For the purposes of forecasting load reductions due to fuel switch HP projects; changes in site energy use at the customer’s meter (using  $\Delta kWh$  algorithm below), customer switching estimates, NTG, and any other adjustment factors deemed appropriate, should be used.

The inputs to cost effectiveness screening should reflect the actual impacts on the electric and fuel consumption at the customer meter and, for fuel switching measures, should therefore reflect the decrease in one fuel and increase in another, as opposed to the single savings value calculated in the “Electric and Fossil Fuel Energy Savings” section above. Therefore in addition to the calculation of savings claimed, the following values should be used to assess the cost effectiveness of the measure. For Early Replacement measures, the efficiency terms of the existing unit should be used for the remaining useful life of the existing equipment (6 years for ASHP and Central AC, 6 years for furnace, 8 years for boilers or GSHP, 15 years for electric resistance), and the efficiency terms for a new baseline unit should be used for the remaining years of the measure.

$$\Delta \text{Therms} = [\text{Increased Consumption}]$$

$$\Delta \text{Therms} = - (\text{Therms}_{\text{SPACE}} + \text{Therms}_{\text{SHW}} + \text{Therms}_{\text{COOL}})$$

$$\text{Therms}_{\text{SPACE}} = ((\text{kBtu/hr}_{\text{heat}}) * 1/\text{COP}_{\text{GHP}} * \text{EFLH}_{\text{heat}}) * 1000 / 100,000$$

$$\text{Therms}_{\text{SHW}} = ((T_{\text{out}} - T_{\text{in}}) * \text{HotWaterUse}_{\text{gallon}} * \gamma_{\text{Water}} * 1 * (1/\text{COP}_{\text{GHP}})) / 100,000$$

$$\text{Therms}_{\text{COOL}} = ((\text{kBtu/hr}_{\text{cool}}) * 1/\text{COP}_{\text{GHP}} * \text{EFLH}_{\text{cool}}) * 1,000 / 100,000$$

$$\Delta kWh = [\text{Replaced Consumption}]$$

$$\Delta kWh = (\text{kWh}_{\text{SPACE}} + \text{kWh}_{\text{SHW}} + \text{kWh}_{\text{COOL}})$$

$$\text{kWh}_{\text{SPACE}} = (\text{kBtu/hr}_{\text{heat}}) / 3.412 * 1/\text{COP}_{\text{base}} * \text{EFLH}_{\text{heat}}$$

$$\text{kWh}_{\text{SHW}} = ((T_{\text{out}} - T_{\text{in}}) * \text{HotWaterUse}_{\text{gallon}} * \gamma_{\text{Water}} * 0.975 * (1/\text{TE}_{\text{elecbase}})) / 3413$$

$$\text{kWh}_{\text{COOL}} = (\text{kBtu/hr}_{\text{cool}}) * (1/\text{EER}_{\text{base}}) * \text{EFLH}_{\text{cool}}$$

**MEASURE CODE: CI-HVC-GFHP-V03-240101**

**REVIEW DEADLINE: 1/1/2025**

## 4.4.56 Commercial Duct Sealing

### DESCRIPTION

This measure was developed to reduce the heating and cooling losses from ducts running through un-conditioned spaces, including, but not limited to: unheated/uncooled attics, basements or crawlspaces; or the outdoors. To the extent that the duct runs through a conditioned space, such as occupied rooms, between conditioned building floors, or semi-heated or semi-cooled spaces, this measure is not applicable as it is assumed that all heating or cooling losses from the duct perform beneficial heating or cooling to the conditioned space. This assumption ignores the potential overheating and overcooling of the conditioned space, which energy waste is hereby deemed to be negligible.<sup>1072</sup>

This measure was developed to be applicable to the following program types: RF.

If applied to other program types, the measure savings should be verified.

### DEFINITION OF EFFICIENT EQUIPMENT

The efficient case is installing duct wrap or other insulation to a length of HVAC ductwork. If applied to ductwork that currently, or in the future may transmit cooling air, the insulation must be wrapped with an impermeable vapor barrier.

The efficient duct air sealing case is installing elastomeric sealant externally to cracks and holes in ductwork that completely and permanently seals the ductwork from air leakage. The elastomeric material must remain flexible and adhere to the ductwork during the measure lifetime and to withstand significant swings in ductwork temperature without losing its sealing capability.

### DEFINITION OF BASELINE EQUIPMENT

Baseline equipment is an uninsulated and/or un-sealed duct located within an un-conditioned space. If a duct has previously been insulated but a significant portion of the insulation has deteriorated or fallen off, the program shall verify the duct insulation condition and determine whether the duct can be considered “un-insulated” for purposes of applying for an incentive.

### DEEMED LIFETIME OF EFFICIENT EQUIPMENT

The measure life is assumed to be 20 years.<sup>1073</sup>

### DEEMED MEASURE COST

The actual installation cost should be used if known. If unknown, the measure cost for duct insulation, including material and installation, is assumed to be \$8.00 per square foot<sup>1074</sup> and for duct crack sealing, including materials and installation, is assumed to be \$15.00 per linear foot.<sup>1075</sup>

### LOADSHAPE

Loadshape C01 – Commercial Electric Cooling

Loadshape C03 – Commercial Cooling

Loadshape C04 – Commercial Electric Heating

---

<sup>1072</sup> It is recommended that additional analyses be considered using custom analysis to determine the extent of overheating or overcooling from uninsulated or unsealed ductwork running through conditioned spaces.

<sup>1073</sup> Measure Life Report, Residential and Commercial/Industrial Lighting and HVAC Measures, GDS Associates, June 2007.

<sup>1074</sup> Engineering estimate provided by John Johnson.

<sup>1075</sup> Engineering estimate provided by John Johnson.

Loadshape C05 – Commercial Electric Heating and Cooling

**COINCIDENCE FACTOR**

The summer peak coincidence factor for cooling is provided in two different ways below. The first is used to estimate peak savings during the utility peak hour and is most indicative of actual peak benefits, and the second represents the *average* savings over the defined summer peak period, and is presented so that savings can be bid into PJM’s capacity market. Both values provided are based on analysis of Itron eShape data for Missouri, calibrated to Illinois loads, supplied by Ameren.

$$CF_{SSP} = \text{Summer System Peak Coincidence Factor for Commercial cooling (during system peak hour)}$$

$$= 91.3\%^{1076}$$

$$CF_{PJM} = \text{PJM Summer Peak Coincidence Factor for Commercial cooling (average during peak period)}$$

$$= 47.8\%^{1077}$$

---



---

**Algorithm**

---



---

**CALCULATION OF ENERGY SAVINGS**

**ELECTRIC ENERGY SAVINGS**

Where available, savings from duct Insulation measures should be determined through a custom analysis. When that is not feasible for the program, the following engineering algorithms can be used.

$$\Delta kWh = \Delta kWh_{cooling} + \Delta kWh_{heatingElectric} + \Delta kWh_{heatingGas}$$

Where:

$$\Delta kWh_{cooling} = \text{If building is cooled, reduction in annual cooling requirement due to duct insulation}$$

$$= [ (1 / R_{Duct_{Exist}} - 1 / R_{Duct_{Efficient}}) * A_{Duct} + 1.08 * CFM_{Saved} ] * EFLH_{Cool} * ( Avg_{Clg\_OAT} - Avg_{Duct\_Clg\_SAT} ) / 1000 / \eta_{Cool} * \%Cool$$

Where:

- $R_{Duct_{Efficient}}$  = Average R-value of proposed duct assembly after installation of additional insulation  
= Actual
- $R_{Duct_{Exist}}$  = Average R-value value of existing duct assembly, including any existing insulation  
= if duct is uninsulated, the average R-value deemed to be 0.8 hr-sf-F/BTU<sup>1078</sup>
- $A_{Duct}$  = Net area of duct proposed to be insulated (ft<sup>2</sup>)  
= Actual
- 1.08 = Specific heat of air x density of inlet air @ 70F x 60 min/hr in BTU
- $CFM_{Saved}$  = Quantity of duct leakage saved by application of crack sealant to previously unsealed ductwork

<sup>1076</sup> Based on analysis of Itron eShape data for Missouri, calibrated to Illinois loads, supplied by Ameren. The AC load during the utility’s peak hour is divided by the maximum AC load during the year.

<sup>1077</sup> Based on analysis of Itron eShape data for Missouri, calibrated to Illinois loads, supplied by Ameren. The average AC load over the PJM peak period (1-5pm, M-F, June through August) is divided by the maximum AC load during the year.

<sup>1078</sup> ASHRAE. Inside duct air film assumed to be <0.1 hr-sf-F/BTU; Outside of duct assumed to be in still air with air film R-value of 0.79 hr-sf-F/BTU,

= CFM/Ft for average crack width from table below<sup>1079</sup>, adjusted for actual duct internal pressure<sup>1080</sup> \* Length of Crack (Ft.)

Average Crack Width (Inches)	CFM Air Leakage per Foot of Crack @ 0.3" w.c. duct
0.00	0 CFM
0.05	7 CFM
0.10	13 CFM
0.15 (Default if Unknown)	20 CFM
0.20	26 CFM
0.25	33 CFM
0.30	39 CFM
0.35	46 CFM
0.40	52 CFM
0.45	59 CFM
0.50	65 CFM
Unknown	20 CFM

EFLH<sub>Cool</sub> = Equivalent Full Load Hours for cooling in Existing Buildings are provided in section 4.4 HVAC End Use

Avg\_Clg\_OAT = Deemed average ambient air temperature over the cooling season in the building space through which the HVAC duct runs, based on climate zone:<sup>1081</sup>

Climate Zone	Cooling Season Avg OA DBT
1 - Rockford	71.3 degF
2 - Chicago	73.7 degF
3 - Springfield	70.7 degF
4 - Belleville	76.3 degF
5 - Marion	69.0 degF

Avg\_Duct\_Clg\_SAT = 60 degF.<sup>1082</sup>

<sup>1079</sup> ASHRAE Fundamentals (2017), Page 16.28, Fig 14. Elevator door CFM assumed to apply to low-rise commercial buildings. Straight line regression analysis was used by ASHRAE: CFM values from 0.0" to 0.2" crack width for personnel doors; and CFM values from 0.0" to 0.3" crack width for elevator doors. The same straight line regression formula is assumed to apply to larger crack widths up to 0.5.

<sup>1080</sup> ASHRAE Fundamentals (2017), Page 16.28, Fig. 14: "For other dP, Multiply Leakage Rate by (dP/0.3)<sup>0.55</sup> .

<sup>1081</sup> BinMaker Pro weather data, based on average outdoor air temperatures over the hottest 5 calendar months. Outdoor average temperatures is assumed to be equivalent to the average temperatures of typical duct locations in: attics, basements, crawl spaces and outdoors. Additional research is recommended to verify actual average ambient temperatures in these areas; additional inputs may be recommended to identify the actual space type of the duct and create a lookup table based on space type and climate zone.

<sup>1082</sup> Engineering estimate by John Johnson – Leidos, based on estimate of average supply air temperature, both for continuous fan operation scenarios and automatic on/off fan operation scenarios. Additional research is recommended to verify actual average duct cooling supply temperatures; additional inputs may be recommended to identify HVAC fan control modes and create a lookup table based on fan control mode type and climate zone.

- 24 = Converts days to hours
- 1000 = Converts Btu to kBtu
- $\eta_{Cool}$  = Efficiency of cooling system. Actual, if known. Alternatively, use IECC 2012 as a default source if equipment type is known, or as deemed from table below<sup>1083</sup>

Space Cooling / Heating Source	Deemed Cooling EER	Deemed Cooling SEER
No Cooling	N/A	N/A
Unknown Cooling Source	11	13

- %Cool = Percent of building **where duct insulation is to be installed** that is cooled
- = Actual %, if known, or, If actual % unknown, use following deemed values:

Is Space Being Insulated Cooled?	Deemed %Cool, if actual % is unknown
Yes	100%
No	0%

**For example**, insulating an uninsulated 300 ft<sup>2</sup> duct and sealing 473 cfm leakage for an Assembly Building Type in Rockford with unknown cooling system:  $R_{Duct_{Exist}} = 0.8$ ;  $R_{Duct_{Efficient}} = 12.8$ ;  $A_{Duct} = 300$ ;  $CFM_{Saved} = 473$ ;  $EFLH_{Cool} = 725$ ;  $Avg\_Clg\_OAT = 71.3$ ;  $Avg\_Duct\_Clg\_SAT = 60$ ;  $\eta_{Cool} = 13.0$ ; %Cool = 100%

$$\Delta kWh_{cooling} = ( (1 / 0.8 - 1 / 12.8 ) * 300 + 1.08 * 473 ) * 725 * ( 71.3 - 60 ) / 1000 / 13.0 * 100\% = 543 \text{ kWh}$$

$\Delta kWh_{heatingElectric}$  = If electric heat (resistance or heat pump), reduction in annual electric heating due to wall and/or foundation insulation

$$= [(1 / R_{Duct_{Exist}} - 1 / R_{Duct_{Efficient}}) * A_{Duct} + 1.08 * CFM_{Saved}] * EFLH_{Heat} * (Avg\_Htg\_SAT - Avg\_Duct\_Htg\_OAT) / \eta_{Heat} / 3412 * \%ElectricHeat$$

Where:

- $EFLH_{Heat}$  = Equivalent Full Load Hours for heating in Existing Buildings are provided in section 4.4 HVAC End Use
- $Avg\_Htg\_OAT$  = Deemed average ambient air temperature over the cooling season in the building space through which the HVAC duct runs, based on climate zone:<sup>1084</sup>

<sup>1083</sup> Simplified version of IECC 2012 as a conservative estimate of what is existing

<sup>1084</sup> BinMaker Pro weather data, based on average outdoor air temperatures over the hottest 5 calendar months. Outdoor average temperatures is assumed to be equivalent to the average temperatures of typical duct locations in: attics, basements, crawl spaces and outdoors. Additional research is recommended to verify actual average ambient temperatures in these areas; additional inputs may be recommended to identify the actual space type of the duct and create a lookup table based on space type and climate zone.

Climate Zone	Heating Season Avg OA DBT
1 - Rockford	29.4 degF
2 - Chicago	34.2 degF
3 - Springfield	27.4 degF
4 - Belleville	38.4 degF
5 - Marion	31.4 degF

Avg\_Duct\_Htg\_SAT = 85 degF.<sup>1085</sup>

$\eta_{Heat}$  = Efficiency of heating system, as deemed from table below

System Type	Cooling Capacity of Equipment	Age of Equipment	HSPF Estimate	$\eta$ (Effective COP Estimate) (HSPF/3.413)
Heat Pump <sup>1086</sup>	All	Before 2009	6.8	2.0
	< 65,000 Btu/h	2009 - 2017	7.7	2.3
		2017 on	8.2	2.40
	$\geq 65,000$ Btu/h and < 135,000 Btu/h	2010 on	11.3	3.3
	$\geq 135,000$ Btu/h and < 240,000 Btu/h	2010 on	10.9	3.2
$\geq 240,000$ Btu/h and < 760,000 Btu/h	2010 on	10.9	10.9	3.2
Resistance	N/A	N/A	N/A	1
Natural Gas Furnace or Boiler	N/A	N/A	N/A	0.8 $E_T$

3412 = Converts Btu to kWh

%ElectricHeat = Percent of building ***where duct insulation is to be installed*** that is electrically heated

= Actual %, if known, or, If actual % unknown, use following deemed values:

Is Space Being Insulated Electrically Heated?	Deemed %ElectricHeat, if actual % is unknown
Yes	100%
No	0%

<sup>1085</sup> Engineering estimate by John Johnson – Leidos, based on estimate of average supply air temperature, both for continuous fan operation scenarios and automatic on/off fan operation scenarios. Additional research is recommended to verify actual average duct heating supply temperatures; additional inputs may be recommended to identify HVAC fan control modes and create a lookup table based on fan control mode type and climate zone.

<sup>1086</sup> Minimum heating efficiency standards for heat pumps are sourced from the Code of Federal Standards for Small and Large Commercial Package Air Conditioning and Heating Equipment (Air Cooled), 10 CFR 431.97 with compliance dates of June 16, 2008; January 1, 2010; January 1, 2017; and January 1, 2018. As the first federal appliance standards for heating efficiency for commercial heat pumps went into effect in June 2008, assuming efficiency standards equivalent to residential heat pumps prior to that date.



**For example**, insulating an uninsulated 300 ft<sup>2</sup> duct and sealing 473 cfm leakage for an Assembly Building Type in Rockford with electric resistance heating system:  $R_{Duct_{Exist}} = 0.8$ ;  $R_{Duct_{Efficient}} = 12.8$ ;  $A_{Duct} = 300$ ;  $CFM_{Saved} = 473$ ;  $EFLH_{Heat} = 1787$ ;  $Avg_{Htg\_OAT} = 29.4$ ;  $Avg_{Duct\_Htg\_SAT} = 85$ ;  $\eta_{Heat} = 1.0$ ; %Electric Heat = 100%

$$\Delta kWh_{cooling} = ( (1 / 0.8 - 1 / 12.8) * 300 + 1.08 * 473 ) * 1787 * (85 - 29.4) / 3412 / 1.0 * 100\%$$

$$= 25100 \text{ kWh}$$

$\Delta kWh_{heatingGas}$  = If gas furnace or boiler heat, kWh savings for reduction in combustion fan run time  
 =  $\Delta Therms * F_e * 29.3$

Where:

$\Delta Therms$  = Annual therms of gas space heating saved, as determined below

$F_e$  = Furnace or boiler combustion fan energy consumption as a percentage of annual fuel consumption  
 = 7.7%

29.3 = conversion of therms to kWh (= 100000 / 3412 )

Other variables as defined above

**For example**, if:  $\Delta Therms = 1072$ ;  $F_e = 7.7\%$ , then:

$$\Delta kWh_{heatingGas} = 1072 * 7.7\% * 29.3$$

$$= 2419 \text{ kWh}$$

**For example**, based on the above calculations with electric resistance heat, total annual kWh savings =

$$\text{Total Annual kWh Savings} = 787 + 25100 + 0$$

$$= 25643 \text{ kWh}$$

### SUMMER COINCIDENT PEAK DEMAND SAVINGS

$\Delta kW$  =  $\Delta kWh_{cooling} / EFLH_{Cooling} * CF$

Where:

$\Delta kWh_{cooling}$  = Annual kWh saving in cooling energy use, as determined above

$EFLH_{cooling}$  = Equivalent Full Load Hours for cooling in Existing Buildings are provided in section 4.4 HVAC End Use

$CF_{SSP}$  = Summer System Peak Coincidence Factor for Commercial cooling (during system peak hour)  
 = 91.3%<sup>1087</sup>

<sup>1087</sup> Based on analysis of Itron eShape data for Missouri, calibrated to Illinois loads, supplied by Ameren. The AC load during the utility's peak hour is divided by the maximum AC load during the year.

$$CF_{PJM} = \text{PJM Summer Peak Coincidence Factor for Commercial cooling (average during peak period)}$$

$$= 47.8\%^{1088}$$

**For example** based on example above:  $\Delta kWh_{cooling} = 543$ ;  $EFLH_{Cooling} = 725$ ;  $CF = 0.478$ ; then:

$$\text{Summer Coincident Peak savings} = 543 / 725 * 0.478$$

$$= 0.36 \text{ kW}$$

**NATURAL GAS SAVINGS**

If Natural Gas heating:

$$\Delta \text{Therms} = [ ( 1 / R_{Duct_{Exist}} - 1 / R_{Duct_{Efficient}} ) * A_{Duct} + 1.08 * CFM_{Saved} ] * EFLH_{Heat} * ( Avg_{Htg\_SAT} - Avg_{Duct\_Htg\_OAT} ) / \eta_{Heat} / 100,000 * \%GasHeat$$

Where:

$\%GasHeat$  = Percent of space being retrofitted with insulation that is heated using gas  
 = Actual %, if known, or, If actual % unknown, use following deemed values:

Is Space Being Insulated Heated with Gas?	Deemed %GasHeat, if actual % is unknown
Yes	100%
No	0%

Other variables as defined above

**For example**, insulating an uninsulated 300 ft<sup>2</sup> duct and sealing 473 cfm leakage for an Assembly Building Type in Rockford with unknown gas heating system:  $R_{ExistWall} = 0.8$ ;  $R_{NewWall} = 12.8$ ;  $A_{Duct} = 300$ ;  $CFM_{Saved} = 473$ ;  $EFLH_{Heat} = 1787$ ;  $Avg_{Htg\_OAT} = 29.4$ ;  $Avg_{Duct\_Htg\_SAT} = 85$ ;  $\eta_{Heat} = 0.8$ ;  $\%GasHeat = 100\%$ ; then

$$\text{Annual Therm Savings} =$$

$$( ( 1 / 0.8 - 1 / 12.8 ) * 300 + 1.08 * 473 ) * 1787 * ( 85 - 31.4 ) / 0.8 / 100000 * 100\%$$

$$= 1072 \text{ therms}$$

**WATER AND OTHER NON-ENERGY IMPACT DESCRIPTIONS AND CALCULATION**

N/A

**DEEMED O&M COST ADJUSTMENT CALCULATION**

N/A

<sup>1088</sup> Based on analysis of Itron eShape data for Missouri, calibrated to Illinois loads, supplied by Ameren. The average AC load over the PJM peak period (1-5pm, M-F, June through August) is divided by the maximum AC load during the year.

**MEASURE CODE: CI-HVC-DSEAL-V01-230101**

**REVIEW DEADLINE: 1/1/2026**

## 4.4.57 Condensate Recovery System

### DESCRIPTION

This measure is applied to hot water and steam fossil-fuel fired boiler where partial or no condensate is returned. As more condensate is returned into the boiler system, less make-up water is required, saving fossil-fuel, make-up water chemical, and treatment cost<sup>1089</sup>. Less condensate discharged into the sewer also means reduced disposal costs and reduction in energy losses due to energy blowdown<sup>1090</sup>. The measure is applicable to commercial applications, commercial HVAC including multifamily buildings, low pressure applications, medium pressure industrial applications, and high-pressure industrial applications.

This measure was developed to be applicable to the following program types: TOS, RF. If applied to other program types, the measure savings should be verified.

### DEFINITION OF EFFICIENT EQUIPMENT

The efficient equipment is defined as functional steam or hot water system that increase the return of condensate in comparison to the baseline case. New systems are not eligible for this measure.

### DEFINITION OF BASELINE EQUIPMENT

Baseline is an existing steam or hot water boiler system where minimal or no condensate is returned.

### DEEMED LIFETIME OF EFFICIENT EQUIPMENT

The expected measure life is assumed to be 15 years<sup>1091</sup>.

### DEEMED MEASURE COST

If known, the actual material and labor cost of installation should be used. If unknown, the average measure cost per GPM of condensate returned is \$12.21<sup>1092</sup>. This cost includes material and labor for installing condensate recovery systems (storage tanks, pipes and pumps).

### LOADSHAPE

Loadshape C35 – Industrial Process  
Loadshape C36 – HVAC Pump motor (heating)

### COINCIDENCE FACTOR

For process boiler systems, the summer peak coincidence factor for this measure is dependent on the industrial shift and corresponding hours of operation. Values are provided for each shift type in the variable definition section.

N/A for space heating boiler systems.

---

<sup>1089</sup> Vineeth C, M G Prince. Impact of Condensate Recovery on Boiler Fuel Consumption in Textile Sector. Vol. 3. Issue 5

<sup>1090</sup> U.S. DOE. Return Condensate to the Boiler. [Energy.gov/sites/prod/files/2014/05/f16/steam8\\_boiler.pdf](https://www.energy.gov/sites/prod/files/2014/05/f16/steam8_boiler.pdf)

<sup>1091</sup> Table 4 Chapter 36, Comparison of Service Life Estimates, 2007 ASHRAE Handbook, HVAC Applications

<sup>1092</sup> Results from Condensate Recovery efficiency improvement research through the C&I and Public Sector Custom Rebate Program, and Small Business Program. The evaluation included project and population data from years 2016 – 2022.

**Algorithm**

**CALCULATION OF ENERGY SAVINGS**

**ELECTRIC ENERGY SAVINGS**

This measure results in additional electric use due to the addition of the condensate pump.

$$\Delta kWh = - \left( HP_{\text{motor}} \times 0.746 \times \frac{LF}{\eta_{\text{motor}}} \right) \times \text{hours}$$

Where:

HP<sub>motor</sub> = Installed nameplate motor horsepower

LF = Actual. If unknown:

E.D.R (sq. ft)	Pump <sup>1093</sup> USGPM	Pump Discharge Pressure PSI	Motor <sup>1094</sup> HP
Boiler HP			3500 RPM
BTUH (1000's)			
lbm <sub>steam</sub> /hr			
1,000	1.50	10	1/2
7		20	1/2
240		30	1/2
250		40	3/4
2,000	3.00	10	1/2
14		20	1/2
480		30	1/2
500		40	3/4
		50	1 1/2
4,000	6.00	10	1/2
29		20	1/2
960		30	1/2
1,000		40	3/4
		50	1 1/2
6,000	9.00	10	1/2
43		20	1/2
1,440		30	1/2
1,500		40	3/4
		50	1 1/2
10,000	15.00	10	1/2
71		20	1/2

<sup>1093</sup> Condensate pumps are rated in square feet EDR. To convert boiler rating to square feet EDR use the following conversion factors:

Multiply boiler horsepower (BHP) by 140 to get square feet EDR

Divide Btu/h by 240 to get square feet EDR

Multiply lbs of steam per hour by 4 to get square feet EDR

A boiler can put out half a gallon per 1000 sq ft EDR per minute. Size the pump capacity for twice to three times the return rate.

Then assign a motor HP based on the system's pressure requirement.

<sup>1094</sup> Steve Almgreen. "How to size a condensate return unit" Xylem Inc, 2015. Steam Team Products

E.D.R (sq. ft)	Pump <sup>1093</sup> USGPM	Pump Discharge Pressure PSI	Motor <sup>1094</sup>
Boiler HP			HP
BTUH (1000's)			3500
lbm <sub>steam</sub> /hr			RPM
2,400		30	1/2
2,500		40	1
		50	2
20,000	30.00	10	1/2
143		20	1/4
4,800		30	1
5,000		40	1 1/2
		50	2
25,000	37.50	10	3/4
179		20	1
6,000		30	1 1/2
6,250		40	1 1/2
		50	2 1/2
30,000	45.00	10	3/4
214		20	1
7,200		30	1 1/2
7,500		40	2 1/2
		50	5
40,000	60.00	10	1 1/2
286		20	1 1/2
9,600		30	2
10,000		40	5
		50	5
50,000	75.00	10	2
357		20	2
12,000		30	3
12,500		40	5
		50	7 1/2
65,000	97.50	10	2
464		20	2 1/2
15,600		30	2 1/2
16,250		40	5
		50	7 1/2
		60	7 1/2
80,000	120.00	10	2 1/2
571		20	2 1/2
19,200		30	2 1/2
20,000		40	5
		50	7 1/2

E.D.R (sq. ft)	Pump <sup>1093</sup> USGPM	Pump Discharge Pressure PSI	Motor <sup>1094</sup>
Boiler HP			HP
BTUH (1000's)			3500
lbm <sub>steam</sub> /hr			RPM
		60	7 1/2
100,000	150.00	10	3
714		20	3
24,000		30	3
25,000		40	5
		50	7 1/2
		60	10

0.746 = Conversion factor from horsepower to kW (kW/hp)

$\frac{LF}{\eta_{motor}}$  = Combined as a single factor since efficiency is a function of load

Where:

LF = Load Factor; Ratio of the peak running load to the nameplate rating of the motor

= Actual, or if unknown 0.65<sup>1095</sup>

$\eta_{motor}$  = Motor efficiency at pump operating conditions

= Actual

HOURS = Annual operating hours of the pump

For space heating

= Operating hours of heating system

For other processes

= Actual. If unknown:

Shift	Hours
Single shift (8/5)	1,976 hours 7 AM – 3 PM, weekdays, minus some holidays and scheduled down time
2-shift (16/5)	3,952 hours 7AM – 11 PM, weekdays, minus some holidays and scheduled down time
3-shift (24/5)	5,928 hours 24 hours per day, weekdays,
4-shift (24/7)	8,320 hours 24 hours/day, 7 days a week minus some holidays and scheduled down time
Unknown / Weighted average <sup>1096</sup>	5,702 hours

<sup>1095</sup> “Measured Loading of Energy Efficient Motors - the Missing Link in Engineering Estimates of Savings,” ACEEE 1994 Summer Study Conference, Asilomar, CA.

<sup>1096</sup> Weighting of 16% single shift, 23% two shift, 25% three shift and 36% continual based on DOE evaluation of the Compressed Air Challenge, section 2.1.5 Facility Operating Schedules.

**SUMMER COINCIDENT PEAK DEMAND SAVINGS**

$$\Delta kW = - \left( HP_{\text{motor}} \times 0.746 \times \frac{LF}{\eta_{\text{motor}}} \right) \times CF$$

Where:

CF = Summer Coincident Peak Factor for measure

**FOSSIL FUEL SAVINGS (WATER SAVINGS MUST BE CALCULATED FIRST)**

Fossil-fuel savings are calculated by estimating the amount of water that is discharged into the sewer. Savings are calculated on the enthalpy difference between make-up water and condensate temperature.

$$\Delta \text{Therms} = \frac{\Delta \text{Water} \times 8.33 \times (H_r - H_w) \times (1 - S_{\text{loss}})}{\eta_{\text{boiler}} \times 100,000}$$

The calculated water savings (in gallons/year) is in turn, used to calculate fossil-fuel savings. The condition of condensate recovery systems varies widely between facilities. Flow meter readings or make-up water records are required for accurate calculations. For condensate systems where partial condensate is returned, a custom calculation is suggested.

$$\Delta \text{Water} = \left[ \frac{\text{EFLH} \times \text{Capacity}}{[(H_s - H_r)(\% \text{Existing}) + (H_s - H_w)(1 - \% \text{Existing})] \times 8.33} \right] \left[ \frac{\% \text{Proposed} - \% \text{Existing}}{1 - \% \text{Existing}} \right]$$

$\Delta \text{Water}$  = Condensate water (gal) discharged into sewer that is saved after recovery systems are in place.

8.33 = specific mass in pounds of one gallon of water (lbm/gal)  
= Actual if known.

EFLH = Equivalent Full Load hours for heating in Existing Buildings are provided in section 4.4 HVAC End Use

Capacity = Nominal Heating Input Capacity Boiler Size (Btu/hr) for existing unit  
= Custom Boiler input capacity in btu/hr

$H_s$  = Enthalpy of supplied steam or hot water<sup>1097</sup>, (Btu/lbm)

System Type	Supply Fluid temperature <sup>1098, 1099</sup> (°F)	Enthalpy of steam or hot water (Btu/lbm)
Hot Water space heating with outdoor reset - Non recirculation	155	123
Hot Water space heating without outdoor reset - Non recirculation	180	148
Hot Water space heating with outdoor reset – Recirculation heating season only	155	123

<sup>1097</sup> Taken from IL TRM Measure 4.4.14 Pipe Insulation

<sup>1098</sup> A typical design uses a  $\Delta 20^\circ\text{F}$  from hot water supply temperature to return temperature. ASHRAE. Boiler System Efficiency. 2006. <http://goesheatingsystems.com/wp-content/uploads/2015/04/BoilerEfficiencyArticle.pdf>

<sup>1099</sup> Typical hot water boiler operating temperature is  $180^\circ\text{F}$ . ASHARE. Boiler system Efficiency. 2006. <http://goesheatingsystems.com/wp-content/uploads/2015/04/BoilerEfficiencyArticle.pdf>



System Type	Supply Fluid temperature <sup>1098, 1099</sup> (°F)	Enthalpy of steam or hot water (Btu/lbm)
Hot Water space heating without outdoor reset – Recirculation heating season only	180	148
Hot Water space heating with outdoor reset – Recirculation year-round	140	108
Hot Water space heating without outdoor reset – Recirculation year-round	180	148
Domestic Hot Water	135	103
5 psi Steam (low pressure)	225	1,155
15 psi Steam (low pressure)	250	1,163
40 psi Steam (low pressure)	287	1,176
65 psi Steam (high pressure)	312	1,183
100 psi Steam (high pressure)	338	1,190

$H_r$  = Enthalpy of return hot water or steam (Btu/lbm)

The condensate fluid temperature assumption used depends upon both the system type and whether there are outdoor reset controls<sup>1100</sup>:

System Type	Return Fluid Temperature <sup>1101</sup> (°F)	Enthalpy of condensate (Btu/lbm)
Hot Water space heating with outdoor reset - Non recirculation	135	103
Hot Water space heating without outdoor reset - Non recirculation	160	128
Hot Water space heating with outdoor reset – Recirculation heating season only	135	103
Hot Water space heating without outdoor reset – Recirculation heating season only	160	128
Hot Water space heating with outdoor reset – Recirculation year-round	120	88
Hot Water space heating without outdoor reset – Recirculation year-round	160	128
Domestic Hot Water	115	83
5 psi Steam (low pressure)	225	193
15 psi Steam (low pressure)	250	219
40 psi Steam (low pressure)	287	256
65 psi Steam (high pressure)	312	282
100 psi Steam (high pressure)	338	309
150 psi Steam (high pressure)	365	338

$H_w$  = Enthalpy of incoming water from well or municipal system (Btu/lbm)  
 = 18.8 Btu/lbm for an incoming water temperature of 50.7°F<sup>1102</sup>

$S_{loss}$  = Percentage of flash steam loss  
 = 12%<sup>1103</sup> or actual if known.

%existing = Percentage of existing condensate recovery  
 = 0% if no condensate is recovered or Actual If known

<sup>1100</sup> Taken from IL TRM Measure 4.4.14 Pipe Insulation

<sup>1101</sup> A typical design uses a  $\Delta 20^\circ\text{F}$  from hot water supply temperature to return temperature. ASHRAE. Boiler System Efficiency. 2006. <http://goeshheatingsystems.com/wp-content/uploads/2015/04/BoilerEfficiencyArticle.pdf>

<sup>1102</sup> Table 4 in Chen, et. al., “Calculating Average Hot Water Mixes of Residential Plumbing Fixtures”, June 2020, reports a value of 50.7°F for inlet water temperature for U.S. Census Division 3.

<sup>1103</sup> U.S. Department of Energy. Return Condensate to the Boiler. [https://www.energy.gov/sites/prod/files/2014/05/f16/steam8\\_boiler.pdf](https://www.energy.gov/sites/prod/files/2014/05/f16/steam8_boiler.pdf)

%proposed	= Percentage of proposed condensate recovery = 80% <sup>1104</sup> or actual if known
n <sub>boiler</sub>	= Efficiency of the steam or hot water boiler = Actual or if unknown use default values given below: = 81.9% for water boilers <sup>1105</sup> = 80.7% for steam boilers, except multifamily low-pressure <sup>1106</sup> = 64.8% for multifamily low-pressure steam boilers <sup>1107</sup>
100,000	= Btu to therms for natural gas conversion factor. For other fossil-fuel, find appropriate conversion.

**For example**, for a Chicago 1,500 kbtu/hr steam boiler in an elementary school operating at 5 psi with a failed condensate return system.

$$\Delta\text{Therms} = ((1,603 * 1,500,000 * (193 - 18.8) * (1 - 0.12)) / ((193 - 18.8) * 0 + (1,155 - 18.8) * 0.8)) * ((0.8 - 0) / 1) * (1 / (0.807 * 100,000))$$

$$= 3,216 \text{ therms.}$$

#### WATER AND OTHER NON-ENERGY IMPACT DESCRIPTIONS AND CALCULATION

The methodology for calculating water savings involves obtaining the gallons of water that is dumped into the drain. Refer to fossil-fuel savings for calculation.

#### DEEMED O&M COST ADJUSTMENT CALCULATION

Maintenance personnel should complete annual or semi-annual maintenance inspections of the condensate return system for its optimal performance. The O&M cost shall be included in cost-effectiveness calculations. It is recommended to service the following components to maintain the system’s proper operation: pumps, ensure periodic lubrication for motors, in accordance with the motor manufacturer’s guidelines. Strainers, traps should also be included as an O&M consideration. A custom calculation should be used as necessary.

**MEASURE CODE: CI-HVC-CNDR-V01-230101**

**REVIEW DEADLINE: 1/1/2026**

<sup>1104</sup> Okbaendrias, Biniam. Energy Management in Industries: Analysis of energy savings potential by steam condensate return. Page 10. About 75-85% of the total condensate return in reasonable.

<sup>1105</sup> Average efficiencies of units from the California Energy Commission (CEC).

<sup>1106</sup> Ibid.

<sup>1107</sup> Katrakis, J. and T.S. Zawacki. “Field-Measured Seasonal Efficiency of Intermediate-sized Low-Pressure Steam Boilers”. ASHRAE V99, pt. 2, 1993.

## 4.4.58 Steam Trap Monitoring System

### DESCRIPTION

The measure applies to the installation of a steam trap monitoring system. The measure is applicable to commercial applications, commercial HVAC including multifamily buildings, and industrial applications. An existing measure, 4.4.16 Steam Trap Replacement or Repair, covers the replacement of a faulty steam trap in the failed open or leaking state. In addition to the steam trap replacement savings, the proposed measure allows to account for savings due to faster repair of the steam traps. Once a failed steam trap is detected, it can be immediately repaired/replaced. Continuous steam trap monitoring leaves behind manual inspections (audits) by using sensors to transmit real-time conditions of the steam system.

Energy savings for each steam trap occurs only when failed open, and steam trap failure rates vary based on trap size, type, and pressure. Energy savings are calculated on a per trap basis with the assumed annual failure rate for each application. Separate savings methodologies are recommended for space heating and process heating applications.

This measure was developed to be applicable to the following program types: TOS, RF. If applied to other program types, the measure savings should be verified.

### DEFINITION OF EFFICIENT EQUIPMENT

Customers must install a steam trap monitoring system on properly functioning steam traps serving either space heating or process heating load. The monitoring system must be capable of tracking the following, but not limited to, number of steam traps, trap type, operating pressure, operating temperature, ambient temperature, trap condition, date/time, application, and trap location. Applicants must provide characteristics for the steam system such as heating efficiency, steam trap orifice size(s), and system pressure(s). Customer must commit to repairing/replacing steam traps identified as failed by the steam trap monitoring system.

### DEFINITION OF BASELINE EQUIPMENT

The baseline criterion are functioning steam traps serving either space heating or process heating load with no pre-existing monitoring system. No minimum leak rate is required.

### DEEMED LIFETIME OF EFFICIENT EQUIPMENT

10 years based on vendor estimates.<sup>1108</sup>

### DEEMED MEASURE COST

The costs are subject to the subscription period chosen by the customer as shown in table below. The approximate installed cost is per trap per year and includes sensors, gateway, cellular service, cloud hosting, User license, data, and reports.

Number of Traps	Term <sup>1109</sup>				
	1 Year	2 Years	3 Years	4 Years	5 Years
100 – 250	\$300	\$282	\$265	\$249	\$234
250 – 499	\$291	\$274	\$257	\$242	\$227
500 – 999	\$282	\$265	\$249	\$234	\$220
1000 – 1999	\$274	\$257	\$242	\$227	\$214
2000 – 2999	\$266	\$250	\$235	\$221	\$207
3000 – 4999	\$262	\$246	\$232	\$218	\$204

<sup>1108</sup> Measure life as referenced in Michigan CI Technologies & Franklin Energy “Work paper FES-H8a – Steam Trap Monitoring System” dated September 2016.

<sup>1109</sup> The Evaractive Steam Trap Monitoring Service Price

Number of Traps	Term <sup>1109</sup>				
	1 Year	2 Years	3 Years	4 Years	5 Years
5000 – 5999	\$258	\$242	\$228	\$214	\$201
6000 – 6999	\$254	\$238	\$224	\$210	\$198
7000+	\$251	\$235	\$221	\$207	\$196

Additional costs exist for the repair or replacement of steam traps once identifying a fault.

**LOADSHAPE**

N/A

**COINCIDENCE FACTOR**

N/A

---

**Algorithm**

---

**CALCULATION OF ENERGY SAVINGS**

**ELECTRIC ENERGY SAVINGS**

Secondary kWh Savings for Water Supply and Wastewater Treatment

The following savings should be included in the total savings for this measure but should not be included in TRC tests to avoid double counting the economic benefit of water savings. These savings only apply to situations in which steam is lost from the steam system.

$$\Delta kWh_{water} = \Delta Water \text{ (gallons)} / 1,000,000 \times E_{water \text{ supply}}$$

Where

$$E_{water \text{ supply}} = \text{Water Supply Energy Factor (kWh/Million Gallons)} \\ = 2571^{1110}$$

**SUMMER COINCIDENT PEAK DEMAND SAVINGS**

N/A

**FOSSIL FUEL SAVINGS**

$$\Delta Therm = N \times P_{malfunctioning} \times F_o \times S_a \times \left( \frac{(Hv + Hs \times (T_1 - T_{source})) \times Hours}{(100,000 \times \eta_B)} \right)$$

Where:

N = Total number of steam traps monitored through the steam trap monitoring system

P<sub>malfunctioning</sub> = Annual Percentage of malfunctioning traps

$$P_{malfunctioning} = L \times T_{audit} \times T_u$$

Where:

L = Leaking & Blow-thru

---

<sup>1110</sup> This factor includes 2571 kWh/MG for water supply based on Illinois energy intensity data from a 2012 ISAWWA study. For more information please review Elevate Energy’s ‘IL TRM: Energy per Gallon Factor, May 2018 paper’. Note since the water loss associated with this measure is due to evaporation and does not discharge into the wastewater system, only the water supply factor is used here.

= custom, if unknown:

Steam System	L (%) <sup>1111</sup>
Commercial Dry Cleaners	27%
Commercial Heating (including Multifamily) LPS	27%
Industrial and Process Low Pressure ≤ 15 psig	16%
Medium Pressure > 15 psig < 30 psig	16%
Medium Pressure ≥ 30 < 75 psig	16%
High Pressure ≥ 75 < 125 psig	16%
High Pressure ≥ 125 < 175 psig	16%
High Pressure ≥ 175 < 250 psig	16%
High Pressure ≥ 300 psig	16%

T<sub>audit</sub> = Average time between audits

Custom, if unknown use 1 year

Tu = Average percentage of year trap malfunctions are undetected for steam systems without a steam trap monitoring system

Custom, if unknown use 50%<sup>1112</sup>

F<sub>o</sub> = Failed open to total failed ratio

= Custom, if unknown:

96%, Space heating applications<sup>1113</sup>

98%, Dry cleaners<sup>3</sup>

94%, All other steam systems and applications<sup>3</sup>

S<sub>a</sub> = Steam loss per leaking trap, (lbs/hr)

Hv = Heat of vaporization of steam, (Btu/lbm)

Steam System	Average Inlet Pressure psig	Heat of Vaporization (Btu/lbm) <sup>1114</sup>
Commercial Dry Cleaners	--	890
Commercial Space Heating (including Multifamily) LPS	11.2 <sup>1115</sup>	951
Industrial/Process Low Pressure: psig < 15	11.2 <sup>9</sup>	951
Medium Pressure: 15 ≤ psig < 30	16	944

<sup>1111</sup> Dry cleaners survey data as referenced in CLEAResult "Work Paper Steam Traps Revision #2" Revision 3 dated March 2, 2012.

<sup>1112</sup> The energy savings estimates of this measure assume that without an automatic steam trap monitoring system, manual audits would be performed once per year, so a leaking steam trap would, on average, leak for 6 months before being detected and repaired/replaced when the trap fails

<sup>1113</sup> Results from Steam Trap Audit/Replacement efficiency improvement research through the C&I and public Sector Prescriptive Rebate Program, Small Business Program and the Multi-family program. The evaluation included project and population data from years 2019 through 2022

<sup>1114</sup> Heat of vaporization of steam at the inlet pressure to the steam trap. Implicit assumption that the average boiler nominal pressure where the vaporization occurs, is essentially that same pressure. Referenced in CLEAResult "Work Paper Steam Traps Revision #2" Revision 3 dated March 2, 2012.

<sup>1115</sup> Results from Armstrong International research through the steam trap management platform SAGE. The research population data included Commercial Heating LPS as well as Industrial or Process Low Pressure, < 15 psi applications. The search of the database yield 120,853 steam traps meeting these parameters: Average orifice size 0.21" and average pressure 11.2 psi.

Steam System	Average Inlet Pressure psig	Heat of Vaporization (Btu/lbm) <sup>1114</sup>
Medium Pressure: 30 ≤ psig < 75	47	915
High Pressure: 75 ≤ psig < 125	101	880
High Pressure: 125 ≤ psig < 175	146	859
High Pressure: 175 ≤ psig < 250	202	837
High Pressure: 250 ≤ psig < 300	263	816
High Pressure: 300 ≤ psig	--	Custom

H<sub>s</sub> = Specific heat of water, (Btu/(lbm \* °R))  
 = 1.001

T<sub>1</sub> = Temperature of Saturated Steam, (°R)  
 = 507.89 × P<sub>1</sub><sup>0.0962</sup>

Where:

= 507.89 = Constant, °R × (in<sup>2</sup>/lb<sub>f</sub>)<sup>0.0962</sup>

T<sub>source</sub> = 513.67 °R<sup>1116</sup>

Hours = Annual hours when steam system is pressurized  
 = custom, if unknown:

Steam System	Zone (Where applicable)	Hours/Yr <sup>1117</sup>
Commercial Dry Cleaners	All Climate Zones	2,425
Industrial/Process Low Pressure: psig < 15		8,282
Medium Pressure: 15 ≤ psig < 30		8,282
Medium Pressure: 30 ≤ psig < 75		8,282
High Pressure: 75 ≤ psig < 125		8,282
High Pressure: 125 ≤ psig < 175		8,282
High Pressure: 175 ≤ psig < 250		8,282
High Pressure: 250 ≤ psig < 300		8,282
High Pressure: 300 ≤ psig		8,282
Commercial Space Heating LPS	Rockford	4,272
	Chicago	4,029
	Springfield	3,406
	Belleville	2,515
	Marion	2,546
Multifamily Space Heating LPS	For steam traps that are part of steam systems where the boiler cycles on/off to maintain space setpoint temperature or for steam traps located downstream of a steam control valve that opens/closes to maintain setpoint temperature, use Heating EFLH values in Section 4.4 for High Rise or Mid-Rise MF buildings.	

<sup>1116</sup> US DOE Building America Program. Building America Analysis Spreadsheet. For Chicago, IL.

<sup>1117</sup> Medium and high-pressure steam trap annual operating hours based on Navigant analysis of source collected during program implementation by Nicor Gas for GPY1 through GPY4. For each steam trap project, the data provided measure savings description, operating pressure, installation Zip code, business building type, program year, and annual operating hours.

Steam System	Zone (Where applicable)	Hours/Yr <sup>1117</sup>
	For steam traps that are exposed to steam continuously throughout the heating season, use the values listed above for Commercial Space Heating LPS for your appropriate climate zone.	

100,000 = Conversion factor (*Btu/Therms*)

$\eta_B$  = Boiler efficiency

= custom, if unknown:

80.7% for steam boilers, except multifamily low-pressure<sup>1118</sup>

64.8% for multifamily low-pressure steam boilers<sup>1119</sup>

### Space Heating Savings Estimates

For systems used in space heating applications that operate at 5 psig or lower, use the following equation to calculate  $S_a$ <sup>1120</sup>. The condensate return system pressure,  $P_2$ , will typically be atmospheric pressure, 14.696 psia.

$$S_a = 1,519.3 \times P_1 \times D^2 \times \left[ \left( \frac{1}{T_1} \right) \times \left( \frac{\gamma}{\gamma - 1} \right) \times \left( \left( \frac{P_2}{P_1} \right)^{(2/\gamma)} - \left( \frac{P_2}{P_1} \right)^{((\gamma+1)/\gamma)} \right) \right]^{0.5} \times A \times FF$$

Where:

1,519.3 = Constant, ( $s^2 \times {}^\circ R^{0.5}$ )/( $ft \times hr$ )

$P_1$  = Average steam trap inlet pressure (*absolute, psia*). If not available, use defaults provided in table below (note that defaults are provided in psig, not psia)

$D$  = Diameter of orifice, inches. Actual value should be used wherever possible as this value has a significant impact on steam flowrate value.

$\gamma$  = Heat Capacity Ratio (*unitless*)

$$= 5.071 \times 10^{-4} \times P_1 + 1.332$$

$P_2$  = Average steam trap outlet pressure (*absolute, psia*). If unknown, assume atmospheric pressure, 14.696 psia

$A$  = Adjustment factor

= 50%,<sup>1121</sup> all steam systems. This factor accounts for reduction in the maximum theoretical steam flow to the average steam flow (the Enbridge factor).

$FF$  = Flow factor. In addition to the Adjustment factor ( $A$ ), and additional 50% flow factor adjustment is recommended for medium and high-pressure steam systems to address industrial float and thermostatic style traps where additional blockage is possible.

<sup>1118</sup> US DOE Building America Program. Building America Analysis Spreadsheet. For Chicago, IL.

<sup>1119</sup> Katrakis, J. and T.S. Zawacki. "Field-Measured Seasonal Efficiency of Intermediate-sized Low-Pressure Steam Boilers". ASHRAE V99, pt. 2, 1993.

<sup>1120</sup> See "Derivation of Equation for Subsonic Compressible Flow through an Orifice and Supporting Calculations for Illinois TRM Steam Trap Measure" paper for more information

<sup>1121</sup> Enbridge adjustment factor used as referenced in CLEAResult "Work paper Steam Traps Revision #2" Revision 3 dated March 2, 2012 and DOE Federal Energy Management Program Steam Trap Replacement Assessment.

Defaults are provided in table below if custom calculation is not performed. The savings are averages for common orifice diameters ( $1/8, 3/16, 1/4, 5/16$  inches) at an assumed 5 psig.

Savings per Steam Trap Orifice Size <sup>1122</sup>		1/8	3/16	1/4	5/16
$S_a$	(lbs/hr)	3.84	8.64	15.35	23.99
$\Delta$ Therms	(Therms/trap/yr)	14.23	32.02	56.92	88.94

### Process Heating Savings Estimates

Use the following equation, for all other steam systems and applications

$$S_a = 24.24 \times P_1 \times D^2 \times A \times FF$$

Where:

$$24.24 = \text{Constant, } lbm/(hr \times psia \times in^2)$$

Defaults are provided in table below if custom calculation is not performed.

Steam System	Average Steam Trap Inlet Pressure (psig) <sup>1123</sup>	Diameter of Orifice (in)	Adjustment Factor	Flow Factor	$S_a$ <sup>1124</sup> (lbs/trap/hr)	$\Delta$ Therm
Commercial Dry Cleaners	82.8	0.1250	50%	100%	18.5	65
Commercial LPS Space Heating	11.2	0.2100	50%	100%	13.8	101
Industrial/Process Low Pressure: psig < 15	11.2 <sup>1125</sup>	0.2100 <sup>19</sup>	50%	100%	13.8	101
Medium Pressure: 15 ≤ psig < 30	16	0.1875	50%	50%	6.5	84
Medium Pressure: 30 ≤ psig < 75	47	0.2500	50%	50%	23.4	164
High Pressure: 75 ≤ psig < 125	101	0.2500	50%	50%	43.8	296
High Pressure: 125 ≤ psig < 175	146	0.2500	50%	50%	60.7	401
High Pressure: 175 ≤ psig < 250	202	0.2500	50%	50%	82.1	527
High Pressure: 250 ≤ psig < 300	263	0.2500	50%	50%	105.2	658

### WATER AND OTHER NON-ENERGY IMPACT DESCRIPTIONS AND CALCULATION

The hourly water volume saved per each repaired or replaced leaking trap is calculated by dividing the “Steam Loss per Leaking Trap (lbm/hr/trap)” by the density of water saved, 8.33 lbm/gal, that replaces the lost steam. The steam

<sup>1122</sup> Default values are directly calculated using the equations above.

<sup>1123</sup> Medium and high-pressure steam trap inlet pressure based on Navigant analysis of source collected during program implementation by Nicor Gas for GPY1 through GPY4. For each steam trap project, the data provided measure savings description, operating pressure, installation Zip code, business building type, program year, and annual operating hours. Dry cleaning steam trap inlet pressure based on C5 Steam Traps – Nicor FINAL 10.27.11.

<sup>1124</sup> Default values are directly calculated using the equations above.

<sup>1125</sup> Results from Armstrong International research through the steam trap management platform SAGE. The research population data included Commercial Heating LPS as well as Industrial or Process Low Pressure, < 15 psi applications. The search of the database yields 120,853 steam traps meeting these parameters: Average orifice size 0.21” and average pressure 11.2 psi.



loss is provided in the table for parameter  $S_a$ , the “Steam loss per leaking trap” in the Natural Gas savings section above. Annual water savings are calculated using Hours and  $P_{malfunctioning}$ , the annual percentage of malfunctioning traps, as defined above.

Water savings only apply to situations where condensate is lost from the steam system. If a condensate recovery system is in place, assume zero water savings or provide a custom calculation based on site-specific operation.

The annual water savings for a replaced or repaired trap is given by:

$$\Delta Water = GAL \times Hours \times N \times P_{malfunctioning} \times F_o$$

Where:

GAL = average actual water volume saved per leaking trap, as listed in the following table and based on steam system type.

*Other variables as defined above*

Steam System	$S_a$	GAL (gal/hr/trap)
Commercial Dry Cleaners	18.5	2.22
Multifamily LPS Space Heating	6.9	0.83
Industrial/Process Low Pressure: psig < 15	13.8	1.66
Medium Pressure: 15 ≤ psig < 30	6.5	0.79
Medium Pressure: 30 ≤ psig < 75	23.4	2.81
High Pressure: 75 ≤ psig < 125	43.8	5.26
High Pressure: 125 ≤ psig < 175	60.9	7.31
High Pressure: 175 ≤ psig < 250	82.1	9.85
High Pressure: 250 ≤ psig < 300	105.2	12.63
High Pressure: 300 ≤ psig	Calculated	Calculated Steam Loss / 8.33

**DEEMED O&M COST ADJUSTMENT CALCULATION**

N/A

**MEASURE CODE: CI-HVC-STMS-V1-230101**

**REVIEW DEADLINE: 1/1/2025**

## 4.4.59 Ductless Heat Pumps

### DESCRIPTION

A heat pump provides heating or cooling by moving heat between indoor and outdoor air. This measure relates to a split heat pump with an outdoor unit and single or multi indoor units providing conditioned air.

This measure is designed to calculate electric savings for the installation of a ductless mini-split heat pump (DMSHP). DMSHPs save energy in heating mode because they provide heat more efficiently than electric resistance heat and central ASHP systems. Additionally, DMSHPs use less fan energy to move heat and don't incur heat loss through a duct distribution system.

For cooling, the proposed savings calculations are aligned with those of typical replacement systems. DMSHPs save energy in cooling mode because they provide cooling capacity more efficiently than other types of unitary cooling equipment. A DMSHP installed in a building with a central ASHP system will save energy by offsetting some of the cooling energy of the ASHP. In order for this measure to apply, the control strategy for the heat pump is assumed to be chosen to maximize savings per installer recommendation.<sup>1126</sup>

This measure characterizes the following scenarios:

#### New Construction:

- a. The installation of a new DMSHP meeting efficiency standards required by the program in a new building.
- b. Note the baseline in this case should be determined via EM&V and the algorithms are provided to allow savings to be calculated from any baseline condition.

#### Time of Sale:

- a. The planned installation of a new DMSHP meeting efficiency standards required by the program to replace an existing system(s) that does not meet the criteria for early replacement described in section c below.
- b. Note the baseline in this case is an equivalent replacement system to that which exists currently in the home. Where unknown, the baseline should be determined via EM&V and the algorithms are provided to allow savings to be calculated from any baseline condition. The calculation of savings is dependent on whether an incentive for the installation has been provided by both a gas and electric utility, just an electric utility or just a gas utility.

#### Early Replacement/Retrofit:

- a. The early removal or displacement of functioning either electric or gas space heating and/or cooling systems from service, prior to the natural end of life, and replacement with a new DMSHP.
- b. Note the baseline in this case is the existing equipment being replaced/displaced. The calculation of savings is dependent on whether an incentive for the installation has been provided by both a gas and electric utility, just an electric utility or just a gas utility.
- c. Early Replacement determination will be based on meeting the following conditions:
  - The existing unit is operational when replaced/displaced, or
  - The existing unit requires minor repairs, defined as costing less than:<sup>1127</sup>

---

<sup>1126</sup> The whole purpose of installing ductless heat pumps is to conserve energy, so the installer can be assumed to be capable of recommending an appropriate controls strategy. For most applications, the heating setpoint for the ductless heat pump should be at least 2F higher than any remaining existing system and the cooling setpoint for the ductless heat pump should be at least 2F cooler than the existing system (this should apply to all periods of a programmable schedule, if applicable). This helps ensure that the ductless heat pump will be used to meet as much of the load as possible before the existing system operates to meet the remaining load. Ideally, the new ductless heat pump controls should be set to the current comfort settings, while the existing system setpoints should be adjusted down (heating) and up (cooling) to capture savings.

<sup>1127</sup> The Technical Advisory Committee agreed that if the cost of repair is less than 20% of the new baseline replacement cost it can be considered early replacement.

Existing System	Maximum repair cost
Air Source Heat Pump	\$276 per ton
Central Air Conditioner	\$190 per ton
Boiler	\$709
Furnace	\$528
Ground Source Heat Pump	<\$249 per ton

- All other conditions will be considered Time of Sale.
- d. The Baseline efficiency of the existing unit replaced:
- Is the actual SEER (converted to SEER2) value of the unit replaced.
  - If the SEER of the existing unit is unknown use assumptions in variable list below (SEER2\_exist and HSPF2\_exist).
  - If the operational status or repair cost of the existing unit is unknown, use time of sale assumptions or average weighted factors determined via evaluation and the algorithms below.

A weighted average early replacement rate is provided for use when the actual baseline early replacement rates are unknown.

**Deemed Early Replacement Rates For DMSHP**

	Deemed Early Replacement Rate
Early Replacement Rate for DMSHP participants	27% <sup>1128</sup>

This measure was developed to be applicable to the following program types: RF, TOS, NC, EREP.

If applied to other program types, the measure savings should be verified.

**DEFINITION OF EFFICIENT EQUIPMENT**

In order for this characterization to apply, the new equipment must be a high-efficiency, variable-capacity (typically “inverter-driven” DC motor) ductless heat pump system that exceeds the program minimum efficiency requirements.

The following conversion factors are recommended for use if the efficient equipment is not rated under the new testing procedure:<sup>1129</sup>

$$\text{SEER2} = \text{SEER} * X$$

$$\text{EER2} = \text{EER} * X$$

$$\text{HSPF2} = \text{HSPF} * X$$

Where:

X	SEER	EER	HSPF
Ducted	0.95	0.95	0.85
Non-Ducted	1.00	1.00	0.90
Packaged	0.95	0.95	0.84

<sup>1128</sup> Based on ComEd program data from 2018-2020 (1057 DMSHP installs).

<sup>1129</sup> Consortium for Energy Efficiency (CEE), Testing, Testing, M1, 2, 3, Transitioning to New Federal Minimum Standards, CEE Summer Program Meeting, August, 2022.

**DEFINITION OF BASELINE EQUIPMENT**

For these products, baseline equipment includes Air Conditioning and Space Heating:

New Construction:

To calculate savings with an electric baseline, the baseline equipment is assumed to be an Air Source Heat Pump meeting the Federal Standard efficiency level; 14.3 SEER2, 7.5 HSPF2, 9.4 EER2.<sup>1130</sup>

To calculate savings with a furnace/central AC baseline, the baseline equipment is assumed to be an 80% AFUE Furnace and central AC meeting the Federal Standard efficiency level; 13.4 SEER2, 10.6 EER.<sup>1131</sup>

Time of Sale: The baseline for this measure is a new replacement unit of the same system type as the existing unit, meeting the baselines provided below.

Unit Type	Efficiency Standard
Standard sized Ducted ASHP	14.3 SEER2, 9.4 EER2, 7.5 HSPF2
Standard sized Ductless ASHP	14.3 SEER2, 8.5 EER2, 7.5 HSPF2
Natural Gas or LP Furnace	80% AFUE
Natural Gas or LP Boiler	84% AFUE
Oil Furnace	83% AFUE
Oil Boiler	86% AFUE
Central AC	13.4 SEER2, 10.6 EER2

Early replacement / Retrofit: The baseline for this measure is the efficiency of the *existing* heating and cooling equipment for the assumed remaining useful life of the existing unit and a new baseline heating and cooling system for the remainder of the measure life (as provided in table above). Note that in order to claim cooling savings, there must be an existing air conditioning system.

For multifamily buildings, each residence must have existing individual heating equipment. Multifamily residences with central heating do not qualify for this characterization.

**DEEMED LIFETIME OF EFFICIENT EQUIPMENT**

The expected measure life is assumed to be 15 years.<sup>1132</sup>

For early replacement, the remaining life of existing equipment is assumed to be 6 years for ASHP and Central AC, 7 years for furnace, 8 years for boilers<sup>1133</sup> and 15 years for electric resistance.<sup>1134</sup>

**DEEMED MEASURE COST**

New Construction and Time of Sale: The actual installed cost of the DMSHP (including any necessary electrical or distribution upgrades required) should be used (defaults are provided below), minus the assumed installation cost

<sup>1130</sup> The federal Standard does not currently include an EER component for northern states. The value provided is based on scaling CEE Tier 1 ratings for North and Canada (12EER2 for CAC, 10EER2 for ducted HP and 9.0EER2 for ductless HP) proportionally down compared to the Federal baseline SEER2 compared to CEE Tier 1 SEER2 ratings.

<sup>1131</sup> The federal Standard does not currently include an EER component. The value provided is based on Opinion Dynamics and Cadmus metering study of Ameren HVAC program participants; See ‘A/C HVAC Metering Study Memo FINAL 2\_28\_2018’.

<sup>1132</sup> [Based on 2016 DOE Rulemaking Technical Support Document](#), as recommended in Navigant ‘ComEd Effective Useful Life Research Report’, May 2018.

<sup>1133</sup> Assumed to be one third of effective useful life of replaced equipment.

<sup>1134</sup> Assume full measure life (16 years) for replacing electric resistance as we would not expect that resistance heat would fail during the lifetime of the efficient measure.

of the baseline equipment (\$6562 + \$600 per ton for ASHP,<sup>1135</sup> or \$2,011 for a new baseline 80% AFUE furnace, or \$4,053 for a new 84% AFUE boiler,<sup>1136</sup> and \$952 per ton for new baseline Central AC replacement<sup>1137</sup>).

Default full cost of the DMSHP is provided below. Note, for smaller units a minimum cost of \$2,000 should be applied.<sup>1138</sup>

Unit Size	Full Install Cost (\$/ton) <sup>1139</sup>
9-9.9	\$1,443
10-10.9	\$1,605
11-12.9	\$1,715
13+	\$2,041

The incremental cost of the DSMHP compared to a baseline minimum efficiency DSMHP is provided in the table below:<sup>1140</sup>

Efficiency (HSPF2)	Incremental Cost (\$/ton) over an HSPF2 7.5 DHP
8.1-8.9	\$62
9-9.8	\$224
9.9-11.6	\$334
11.7+	\$660

Early Replacement/retrofit (replacing existing equipment): The actual full installation cost of the DMSHP (including any necessary electrical or distribution upgrades required) should be used. The assumed deferred cost (after 8 years) of replacing existing equipment with a new baseline unit is assumed to be \$7,527 + \$688 per ton for a new baseline Air Source Heat Pump, or \$2,296 for a new baseline 80% AFUE furnace or \$4,627 for a new 84% AFUE boiler and \$1,047 per ton for new baseline Central AC replacement.<sup>1141</sup> If replacing electric resistance heat, there is no deferred replacement cost. This future cost should be discounted to present value using the nominal societal discount rate.

Where the DMSHP is a supplemental HVAC system, the full installation cost of the DMSHP (including any necessary electrical or distribution upgrades required) should be used without a deferred replacement cost.

If the install cost is unknown a default is provided above. Fuel switch scenarios are likely to require additional installation work which may include adding new electrical circuits, capping existing gas lines and upgrading electrical panels. These costs are likely to range significantly and actual values should be used wherever possible. If unknown, assume an additional \$300 for fuel switch installations.

**LOADSHAPE**

Loadshape C05 - Commercial Electric Heating and Cooling

<sup>1135</sup> Full install ASHP costs are based upon data provided by Ameren. See ‘ASHP Costs\_06242022’.  
<sup>1136</sup> Furnace and boiler costs are based on data provided in Appendix E of the Appliance Standards Technical Support Documents including equipment cost and installation labor. Where efficiency ratings are not provided, the values are interpolated from those that are.  
<sup>1137</sup> Based on 3 ton initial cost estimate for a conventional unit from ENERGY STAR Central AC calculator  
<sup>1138</sup> The cost per ton table provides reasonable estimates for installation costs of DMSHP, which can vary significantly due to requirements of the home. It is estimated that all units, even those 1 ton or less will be at least \$2000 to install.  
<sup>1139</sup> Full costs based upon full install cost of an ASHP plus incremental costs provided in Memo from Opinion Dynamics Evaluation Team, Ductless Mini-Split Heat Pumps: Incremental Cost Analysis, April 27, 2017.  
<sup>1140</sup> Memo from Opinion Dynamics Evaluation Team, Ductless Mini-Split Heat Pumps: Incremental Cost Analysis, April 27, 2017  
<sup>1141</sup> All baseline replacement costs are consistent with their respective measures and include inflation rate of 1.91%.

**COINCIDENCE FACTOR**

The summer peak coincidence factor for cooling is provided in four different ways below. The first two relate to the use of DMSHP to supplement existing cooling or provide limited zonal cooling, the second two relate to use of the DMSHP to provide whole house cooling. In each pair, the first is used to estimate peak savings during the utility peak hour and is most indicative of actual peak benefits, and the second represents the *average* savings over the defined summer peak period and is presented so that savings can be bid into PJM’s capacity market. Both values provided are based on metering data for 40 DMSHPs in Ameren Illinois service territory.<sup>1142</sup>

For Single Zone DMSHPs providing supplemental or limited zonal cooling:

$$CF_{SSP} = \text{Summer System Peak Coincidence Factor for DMSHP (during utility peak hour)}$$

$$= 43.1\%^{1143}$$

$$CF_{PJM} = \text{PJM Summer Peak Coincidence Factor for DMSHP (average during PJM peak period)}$$

$$= 28.0\%^{1144}$$

For Multi-Zone DMSHPs providing cooling for the whole building:

$$CF_{SSP} = \text{Summer System Peak Coincidence Factor for Commercial cooling (during system peak hour)}$$

$$= 91.3\%^{1145}$$

$$CF_{PJM} = \text{PJM Summer Peak Coincidence Factor for Commercial cooling (average during peak period)}$$

$$= 47.8\%^{1146}$$

---

**Algorithm**

---

**CALCULATION OF ENERGY SAVINGS**

**ELECTRIC ENERGY SAVINGS AND NATURAL GAS SAVINGS**

Non fuel switch measures:

$$\Delta kWh = [\text{Cooling Savings}] + [\text{Heating Savings}]$$

$$= [(\text{CoolingLoad} * (1/SEER2_{Base} - 1/SEER2_{ee}))/1000] + [(\text{HeatLoad} * \text{HeatLoadFactor}_{elec} * (1/(HSPF2_{Base} * HSPF_{ClimateAdj}) - 1/(HSPF2_{ee} * HSPF_{ClimateAdj})) / 1000]$$

Fuel switch measures:

Fuel switch measures must produce positive total lifecycle energy savings (i.e., reduction in Btus at the premises) in order to qualify. This is determined as follows:

$$\text{SiteEnergySavings (MMBTUs)} = \text{FuelSwitchSavings} + \text{NonFuelSwitchSavings}$$

$$\text{FuelSwitchSavings} = \text{GasHeatReplaced} - \text{DMSHPSiteHeatConsumed}$$

<sup>1142</sup> All-Electric Homes PY6 Metering Results: Multifamily HVAC Systems, Cadmus, October 2015

<sup>1143</sup> Based on analysis of metering results from 24 heat pumps in Ameren Illinois service territory in PY5 coincident with AIC’s 2010 system peak; ‘Impact and Process Evaluation of Ameren Illinois Company’s Residential HVAC Program (PY5)’.

<sup>1144</sup> Based on analysis of Itron eShape data for Missouri, calibrated to Illinois loads, supplied by Ameren. The average AC load over the PJM peak period (1-5pm, M-F, June through August) is divided by the maximum AC load during the year.

<sup>1145</sup> Based on analysis of Itron eShape data for Missouri, calibrated to Illinois loads, supplied by Ameren. The AC load during the utility’s peak hour is divided by the maximum AC load during the year.

<sup>1146</sup>Based on analysis of Itron eShape data for Missouri, calibrated to Illinois loads, supplied by Ameren. The average AC load over the PJM peak period (1-5pm, M-F, June through August) is divided by the maximum AC load during the year.

$$\text{NonFuelSwitchSavings} = \text{FurnaceFanSavings} + \text{DMSHPSiteCoolingImpact}$$

$$\text{GasHeatReplaced} = (\text{HeatLoad} * \text{HeatLoadFactor}_{\text{gas}} * 1/\text{AFUE}_{\text{base}}) / 1,000,000$$

$$\text{FurnaceFanSavings} = (\text{FurnaceFlag} * \text{HeatLoad} * \text{HeatLoadFactor}_{\text{gas}} * 1/\text{AFUE}_{\text{base}} * F_e) / 1,000,000$$

$$\text{DMSHPSiteHeatConsumed} = ((\text{HeatLoad} * \text{HeatLoadFactor}_{\text{elec}} * (1/\text{HSPF2}_{\text{ee}} * \text{HSPF}_{\text{ClimateAdj}}))/1000 * 3412) / 1,000,000$$

$$\text{DMSHPSiteCoolingImpact} = ((\text{CoolingLoad} * (1/\text{SEER2}_{\text{Base}} - 1/\text{SEER2}_{\text{ee}}))/1000 * 3412) / 1,000,000$$

If SiteEnergySavings calculated above is positive, the measure is eligible.

The appropriate savings claim is dependent on which utilities are supporting the measure as provided in a table below:

Measure supported by:	Electric Utility claims (kWh):	Gas Utility claims (therms):
Electric utility only	SiteEnergySavings * 1,000,000/3,412	N/A
Electric and gas utility (Note utilities may make alternative agreements to how savings are allocated as long as total MMBtu savings remains the same).	%IncentiveElectric * SiteEnergySavings * 1,000,000/3,412	%IncentiveGas * SiteEnergySavings * 10
Gas utility only	N/A	SiteEnergySavings * 10

Note for Early Replacement measures, the efficiency and Fe terms of the existing unit should be used for the remaining useful life of the existing equipment (6 years for ASHP and Central AC, 6 years for furnace, 8 years for boilers, 15 years for electric resistance), and the efficiency and Fe terms for a new baseline unit should be used for the remaining years of the measure. See assumptions below.

Where:

CoolingLoad = Annual cooling load being displaced

$$= \text{Capacity}_{\text{cool}} * \text{EFLH}_{\text{cool}}$$

Capacity<sub>cool</sub> = the cooling output capacity of the ductless heat pump unit in Btu/hr<sup>1147</sup>

= Actual installed

EFLH<sub>cool</sub> = Equivalent Full Load Hours for cooling in Existing Buildings or New Construction are provided in section 4.4 HVAC End Use.

SEER2<sub>base</sub> = Seasonal Energy Efficiency Ratio of the baseline equipment (the equipment being either replaced or displaced)

= SEER from tables below, based on the applicable Code on the date of equipment purchase (if unknown assume current Code). If baseline equipment is rated in EER, convert to SEER using the formula:  $\text{EER2} = (-0.02 * \text{SEER2}^2) + (1.12 * \text{SEER2})$

SEER2<sub>ee</sub> = SEER rating of new equipment (kbtu/kwh)

<sup>1147</sup> 1 Ton = 12 kBtu/hr

= Actual installed<sup>1148</sup>

HeatLoad = Calculated heat load being displaced

=  $EFLH_{heat} * Capacity\_DMSHP_{heat}$

$EFLH_{heat}$  = Equivalent Full Load Hours for heating in Existing Buildings or New Construction are provided in section 4.4 HVAC End Use.

Capacity\_DMSHPheat = the total rated 47°F heating output capacity of all the ductless heat pump units installed in Btu/hr

= Actual

HeatLoadFactor = adjustment to reflect the heat load carried by the DMSHP in each use case, considering assumed operational strategy and switchover temperature, as well as DMSHP rated capacity.<sup>1149</sup> If new DMSHP displaces all existing heating systems, assume 1. “Partial Displacement” application refers to the condition where an existing heating system remains in place to meet heating load not provided by the heat pump.

Use factor from table below. For programs where displacement scenario and switchover temperature is unknown, evaluation should determine appropriate weightings of the various scenarios including full displacement, partial displacement and cooling/heating only.

If Partial Displacement and Simultaneous Operation<sup>1150</sup> with existing heat type, HeatLoadFactor:

Climate Zone	≤15 kBtu	>15 and ≤21 kBtu	>21 and ≤27 kBtu	>27 and ≤33 kBtu	>33 and ≤39 kBtu	>39 and ≤45 kBtu	>45 kBtu
1 (Rockford)	2.12	1.80	1.52	1.30	1.12	0.98	0.87
2 (Chicago)	2.25	1.89	1.58	1.33	1.14	0.99	0.87
3 (Springfield)	2.01	1.68	1.40	1.18	1.00	0.87	0.77
4 (Belleville)	2.89	2.34	1.90	1.58	1.34	1.16	1.02
5 (Marion)	2.50	1.93	1.53	1.25	1.05	0.90	0.79
ComEd Weighted Average	2.03	1.72	1.46	1.24	1.07	0.94	0.83
Ameren Weighted Average	2.15	1.81	1.51	1.27	1.09	0.95	0.84
Statewide Weighted Average	2.06	1.74	1.47	1.25	1.07	0.94	0.83

<sup>1148</sup> Note that if only an EER2 rating is available, use the following conversion equation;  $EER2_{base} = (-0.02 * SEER2_{base}^2) + (1.12 * SEER2)$ . From Wassmer, M. (2003). A Component-Based Model for Residential Air Conditioner and Heat Pump Energy Calculations. Masters Thesis, University of Colorado at Boulder.

<sup>1149</sup> Values for HeatLoadFactor were developed by applying DMSHP capacity curves of various sizes to a modeled full home load for each of the five IL TRM climate zones. The modeled home load was developed using eQuest simulation modeling with a home size of 2,500 square feet, single-story with attic construction, and utilizing default values for shell properties, occupancy levels, etc. Thermostat setpoints were fixed to 68F without daytime or nighttime setback. To determine the home load for each climate zone, the model home was simulated using TMY3 weather files specific to the five IL TRM climate zones. The resulting hourly heating loads, 8,760 values for each climate zone, were extracted from eQuest for further analysis.

<sup>1150</sup> The heating setpoint for the ductless heat pump is assumed to be at least 2°F higher than any remaining existing system and the cooling setpoint for the ductless heat pump is assumed to be at least 2°F cooler than the existing system (this should apply to all periods of a programmable schedule, if applicable). This is necessary such that the ductless heat pump is serving as the primary unit for heating and cooling.



If Partial Displacement and Switchover<sup>1151</sup> at >24°F, HeatLoadFactor:

Climate Zone	≤15 kBtu	>15 and ≤21 kBtu	>21 and ≤27 kBtu	>27 and ≤33 kBtu	>33 and ≤39 kBtu	>39 and ≤45 kBtu	>45 kBtu
1 (Rockford)	0.93	0.67	0.50	0.40	0.34	0.29	0.25
2 (Chicago)	1.06	0.77	0.58	0.46	0.39	0.33	0.29
3 (Springfield)	0.92	0.66	0.49	0.39	0.33	0.28	0.25
4 (Belleville)	1.71	1.24	0.93	0.74	0.62	0.53	0.46
5 (Marion)	1.54	1.07	0.80	0.64	0.53	0.46	0.40
ComEd Weighted Average	0.89	0.64	0.48	0.39	0.32	0.28	0.24
Ameren Weighted Average	0.99	0.72	0.54	0.43	0.36	0.31	0.27
Statewide Weighted Average	0.92	0.66	0.50	0.40	0.33	0.28	0.25

If Partial Displacement and Switchover at ≤24°F, HeatLoadFactor

Climate Zone	≤15 kBtu	>15 and ≤21 kBtu	>21 and ≤27 kBtu	>27 and ≤33 kBtu	>33 and ≤39 kBtu	>39 and ≤45 kBtu	>45 kBtu
1 (Rockford)	1.99	1.67	1.39	1.17	0.99	0.86	0.75
2 (Chicago)	2.14	1.78	1.47	1.22	1.03	0.89	0.78
3 (Springfield)	1.91	1.58	1.31	1.08	0.91	0.79	0.69
4 (Belleville)	2.79	2.24	1.80	1.48	1.25	1.07	0.94
5 (Marion)	2.47	1.90	1.50	1.22	1.02	0.88	0.77
ComEd Weighted Average	1.90	1.60	1.33	1.12	0.95	0.82	0.72
Ameren Weighted Average	2.04	1.70	1.40	1.17	0.99	0.85	0.74
Statewide Weighted Average	1.94	1.62	1.35	1.13	0.96	0.83	0.72

HSPF<sub>2base</sub> = Heating Seasonal Performance Factor of the baseline equipment  
 = HSPF from tables below, based on the applicable Code on the date of equipment purchase (if unknown assume current Code).

AFUE<sub>base</sub> = Baseline Annual Fuel Utilization Efficiency Rating. For early replacement measures, use actual AFUE rating where it is possible to measure or reasonably estimate for the remaining useful life of the existing equipment (6 years for furnace, 8 years for boilers). For new systems (time of sale, new construction or remaining years of early replacement), use appropriate code level efficiency. If using rated efficiencies, derate efficiency value by 1% per year (maximum of 30 years) to account for degradation over time,<sup>1152</sup> or if unknown assume default:

<sup>1151</sup> Temperature for switching from heat pump (used for the higher temperatures) to the supplemental system (used for lower temperatures).

<sup>1152</sup> Justification for degradation factors can be found on page 14 of ‘AIC HVAC Metering Study Memo FINAL 2\_28\_2018’. Estimate efficiency as (Rated Efficiency \* (1-0.01)^Equipment Age).

Baseline/ Existing Heating System	AFUEbase		
	Early Replacement (Remaining useful life of existing equipment) <sup>1153</sup>	Early Replacement (Remaining measure life)	Time of Sale or New Construction
Furnace	64.4%	80%	80%
Boiler	61.6%	84%	84%

HSPF2<sub>ee</sub> = HSPF2 rating of new equipment (kbtu/kwh)  
 = Actual installed

HSPF\_ClimateAdj = Adjustment factor to account for observed discrepancy between seasonal heating performance relative to rated HSPF as provided by standard AHRI 210/240 rating conditions.<sup>1154</sup>:

Displacement Scenario	City (county based upon)	HSPF2_ClimateAdj
Partial Displacement	All	100%
Whole Heat Load Displacement	1 (Rockford)	74%
	2 (Chicago)	74%
	3 (Springfield)	87%
	4 (Belleville)	87%
	5 (Marion)	87%
	Weighted Average <sup>1155</sup>	
	ComEd	74%
Ameren	85%	
Statewide	77%	

FurnaceFlag = 1 if system replaced is a gas furnace, 0 if not.

F<sub>e</sub> = Furnace Fan energy consumption as a percentage of annual fuel consumption  
 For Early Replacement (1<sup>st</sup> 6 years) F<sub>e\_Exist</sub> = 3.14%<sup>1156</sup>

<sup>1153</sup> Average nameplate efficiencies of all Early Replacement qualifying equipment in Ameren PY3-PY4.

<sup>1154</sup> Adjustment factors are based on findings from NEEA, July 2020 ‘EXP07:19 Load-based and Climate-Specific Testing and Rating Procedures for Heat Pumps and Air Conditioners’. See ‘NEEA HP data’ for calculation. Findings were consistent with other reviewed sources including ASHRAE, 2020 ‘Right-Sizing Electric Heat Pump and Auxiliary Heating for Residential Heating Systems Based on Actual Performance Associated with Climate Zone’ and Cadmus, 2022 ‘Residential ccASHP Building Electrification Study’. The difference between HSPF and HSPF2 ratings is based on the change in testing procedure that will correct for some of this effect where ducted systems will have an approximately 5% lower HSPF2 rating as compared to HSPF, based on CEE presentation, July 2022, ‘Testing Testing, M1, 2, 3: Transitioning to New Federal Minimum Standards’.

<sup>1155</sup> Weighting for Ameren is based on electric heat accounts in each of the heating zones. Weighting for ComEd and Statewide average is based on number of occupied residential housing units in each zone. ComEd is weighted average of Zones 1-2. Alternative program-weighted assumptions can be used if appropriate.

<sup>1156</sup> F<sub>e</sub> is not one of the AHRI certified ratings provided for residential furnaces, but can be reasonably estimated from a calculation based on the certified values for fuel energy (E<sub>f</sub> in MMBtu/yr) and E<sub>ae</sub> (kWh/yr). An average of a 300 record sample (non-random) out of 1495 was 3.14%. This is, appropriately, ~50% greater than the ENERGY STAR version 3 criteria for 2% F<sub>e</sub>. See “Programmable Thermostats Furnace Fan Analysis.xlsx” for reference.

For New Construction, Time of Sale and early replacement (remaining 10 years)  
 $F_{e\_New} = 1.88\%^{1157}$

3412 = Btu per kWh

%IncentiveElectric = % of total incentive paid by electric utility

= Actual

%IncentiveGas = % of total incentive paid by gas utility

= Actual

Minimum Efficiency Requirements: 2018 IECC (baseline effective 7/1/2019 for New Construction measures)

TABLE C403.3.2(2)  
 MINIMUM EFFICIENCY REQUIREMENTS: ELECTRICALLY OPERATED UNITARY AND APPLIED HEAT PUMPS

EQUIPMENT TYPE	SIZE CATEGORY	HEATING SECTION TYPE	SUBCATEGORY OR RATING CONDITION	MINIMUM EFFICIENCY	TEST PROCEDURE <sup>a</sup>
Air cooled (cooling mode)	< 65,000 Btu/h <sup>b</sup>	All	Split System	14.0 SEER	AHRI 210/240
			Single Package	14.0 SEER	
Through-the-wall, air cooled	≤ 30,000 Btu/h <sup>b</sup>	All	Split System	12.0 SEER	
			Single Package	12.0 SEER	
Single-duct high-velocity air cooled	< 65,000 Btu/h <sup>b</sup>	All	Split System	11.0 SEER	
Air cooled (cooling mode)	≥ 65,000 Btu/h and < 135,000 Btu/h	Electric Resistance (or None)	Split System and Single Package	11.0 EER 12.0 IEER	
		All other	Split System and Single Package	10.8 EER 11.8 IEER	
	≥ 135,000 Btu/h and < 240,000 Btu/h	Electric Resistance (or None)	Split System and Single Package	10.6 EER 11.6 IEER	
		All other	Split System and Single Package	10.4 EER 11.4 IEER	
	≥ 240,000 Btu/h	Electric Resistance (or None)	Split System and Single Package	9.5 EER 10.6 IEER	
		All other	Split System and Single Package	9.3 EER 9.4 IEER	
Water to Air: Water Loop (cooling mode)	< 17,000 Btu/h	All	86°F entering water	12.2 EER	ISO 13256-1
	≥ 17,000 Btu/h and < 65,000 Btu/h	All	86°F entering water	13.0 EER	
	≥ 65,000 Btu/h and < 135,000 Btu/h	All	86°F entering water	13.0 EER	
Water to Air: Ground Water (cooling mode)	< 135,000 Btu/h	All	59°F entering water	18.0 EER	ISO 13256-1
Brine to Air: Ground Loop (cooling mode)	< 135,000 Btu/h	All	77°F entering water	14.1 EER	ISO 13256-1
Water to Water: Water Loop (cooling mode)	< 135,000 Btu/h	All	86°F entering water	10.6 EER	ISO 13256-2
Water to Water: Ground Water (cooling mode)	< 135,000 Btu/h	All	59°F entering water	16.3 EER	
Brine to Water: Ground Loop (cooling mode)	< 135,000 Btu/h	All	77°F entering fluid	12.1 EER	

<sup>1157</sup> New furnaces are required to have ECM fan motors installed. Comparing Eae to Ef for furnaces on the AHRI directory as above, indicates that Fe for new furnaces is on average 1.88%.

**IECC2018 Table C403.3.2(2) continued from previous page:**

Air cooled (heating mode)	< 65,000 Btu/h <sup>b</sup>	—	Split System	8.2 HSPF	AHRI 210/240
		—	Single Package	8.0 HSPF	
Through-the-wall, (air cooled, heating mode)	≤ 30,000 Btu/h <sup>b</sup> (cooling capacity)	—	Split System	7.4 HSPF	
		—	Single Package	7.4 HSPF	
Small-duct high velocity (air cooled, heating mode)	< 65,000 Btu/h <sup>b</sup>	—	Split System	6.8 HSPF	
Air cooled (heating mode)	≥ 65,000 Btu/h and < 135,000 Btu/h (cooling capacity)	—	47°F db/43°F wb outdoor air	3.3 COP	
		—	17°Fdb/15°F wb outdoor air	2.25 COP	
	≥ 135,000 Btu/h (cooling capacity)	—	47°F db/43°F wb outdoor air	3.2 COP	
		—	17°Fdb/15°F wb outdoor air	2.05 COP	
Water to Air: Water Loop (heating mode)	< 135,000 Btu/h (cooling capacity)	—	68°F entering water	4.3 COP	ISO 13256-1
Water to Air: Ground Water (heating mode)	< 135,000 Btu/h (cooling capacity)	—	50°F entering water	3.7 COP	
Brine to Air: Ground Loop (heating mode)	< 135,000 Btu/h (cooling capacity)	—	32°F entering fluid	3.2 COP	
Water to Water: Water Loop (heating mode)	< 135,000 Btu/h (cooling capacity)	—	68°F entering water	3.7 COP	ISO 13256-2
Water to Water: Ground Water (heating mode)	< 135,000 Btu/h (cooling capacity)	—	50°F entering water	3.1 COP	
Brine to Water: Ground Loop (heating mode)	< 135,000 Btu/h (cooling capacity)	—	32°F entering fluid	2.5 COP	

For SI: 1 British thermal unit per hour = 0.2931 W, °C = [(°F) - 32]/1.8.

- a. Chapter 6 contains a complete specification of the referenced test procedure, including the reference year version of the test procedure.
- b. Single-phase, air-cooled heat pumps less than 65,000 Btu/h are regulated by NAECA. SEER and HSPF values are those set by NAECA.

**SUMMER COINCIDENT PEAK DEMAND SAVINGS**

For Single Zone DMSHPs providing supplemental or limited zonal cooling:

CF<sub>SSP</sub> = Summer System Peak Coincidence Factor for DMSHP (during utility peak hour)  
= 43.1%<sup>1158</sup>

CF<sub>PJM</sub> = PJM Summer Peak Coincidence Factor for DMSHP (average during PJM peak period)  
= 28.0%<sup>1159</sup>

For Multi-Zone DMSHPs providing cooling for the whole building:

CF<sub>SSP</sub> = Summer System Peak Coincidence Factor for Commercial cooling (during system peak hour)  
= 91.3%<sup>1160</sup>

CF<sub>PJM</sub> = PJM Summer Peak Coincidence Factor for Commercial cooling (average during peak period)

<sup>1158</sup> Based on analysis of metering results from 24 heat pumps in Ameren Illinois service territory in PY5 coincident with AIC’s 2010 system peak; ‘Impact and Process Evaluation of Ameren Illinois Company’s Residential HVAC Program (PY5)’.

<sup>1159</sup> Based on analysis of Itron eShape data for Missouri, calibrated to Illinois loads, supplied by Ameren. The average AC load over the PJM peak period (1-5pm, M-F, June through August) is divided by the maximum AC load during the year.

<sup>1160</sup> Based on analysis of Itron eShape data for Missouri, calibrated to Illinois loads, supplied by Ameren. The AC load during the utility’s peak hour is divided by the maximum AC load during the year.

$$= 47.8\%^{1161}$$

**NATURAL GAS SAVINGS**

Calculation provided together with Electric Energy Savings above.

**WATER AND OTHER NON-ENERGY IMPACT DESCRIPTIONS AND CALCULATION**

N/A

**DEEMED O&M COST ADJUSTMENT CALCULATION**

N/A

**COST EFFECTIVENESS SCREENING AND LOAD REDUCTION FORECASTING WHEN FUEL SWITCHING**

This measure can involve fuel switching from gas to electric.

For the purposes of forecasting load reductions due to fuel switch DMSHP projects per Section 16-111.5B, changes in site energy use at the customer’s meter (using ΔkWh algorithm below), customer switching estimates, NTG, and any other adjustment factors deemed appropriate, should be used.

The inputs to cost effectiveness screening should reflect the actual impacts on the electric and fuel consumption at the customer meter and, for fuel switching measures, should therefore reflect the decrease in one fuel and increase in another, as opposed to the single savings value calculated in the “Electric and Fossil Fuel Energy Savings” section above. Therefore in addition to the calculation of savings claimed, the following values should be used to assess the cost effectiveness of the measure. For Early Replacement measures, the efficiency terms of the existing unit should be used for the remaining useful life of the existing equipment (6 years for ASHP and Central AC, 6 years for furnace, 8 years for boilers or GSHP, 15 years for electric resistance), and the efficiency terms for a new baseline unit should be used for the remaining years of the measure.

$$\begin{aligned} \Delta\text{Therms} &= [\text{Heating Consumption Replaced}] \\ &= [(\text{HeatLoad} * \text{HeatLoadFactor}_{\text{gas}} * 1/\text{AFUE}_{\text{base}}) / 100,000] \\ \Delta\text{kWh} &= [\text{FurnaceFanSavings}] - [\text{DMSHP heating consumption}] + [\text{Cooling savings}] \\ &= [\text{FurnaceFlag} * \text{HeatLoad} * \text{HeatLoadFactor}_{\text{gas}} * 1/\text{AFUE}_{\text{base}} * F_e * 0.000293] - [(\text{HeatLoad} * \text{HeatLoadFactor}_{\text{elec}} * 1/\text{HSPFee})/1000] + [(\text{Capacity}_{\text{cool}} * \text{EFLH}_{\text{cool}} * (1/\text{SEER}_{\text{Base}} - 1/\text{SEER}_{\text{ee}})) / 1000] \end{aligned}$$

**MEASURE CODE: CI-HVC-DHP-V2-240101**

**REVIEW DEADLINE: 1/1/2025**

---

<sup>1161</sup>Based on analysis of Itron eShape data for Missouri, calibrated to Illinois loads, supplied by Ameren. The average AC load over the PJM peak period (1-5pm, M-F, June through August) is divided by the maximum AC load during the year.

## 4.4.60 Variable Refrigerant Flow HVAC System

### DESCRIPTION

This measure applies to the installation of air source Variable Refrigerant Flow (VRF) HVAC systems. VRF systems are heat pumps that have one outdoor condensing unit with refrigerant piped to multiple indoor evaporator units to deliver cooling and/or heating to individual interior zones as needed. This measure could apply to replacing an existing unit at the end of its useful life or the installation of a new unit in a new or existing building.

This measure was developed to be applicable to the following program times: TOS and NC. If applied to other program types, the measure savings should be verified.

### DEFINITION OF EFFICIENT EQUIPMENT

This measure applies to both retrofit and new construction installations of VRF systems. Savings are based in the inherent efficiency of VRF systems as compared to traditional HVAC systems. VRF systems should meet or exceed ASHRAE 90.1 minimum efficiency requirements for air source VRF systems.

### DEFINITION OF BASELINE EQUIPMENT

#### Time of Sale / New Construction

##### Non-fuel switch measures:

To calculate savings with an electric baseline, the baseline equipment is assumed to be a ducted split-system heat pump for non-residential buildings 25,000 square feet or fewer and is 3 floors or fewer. For non-residential buildings over 25,000 square feet or 4 floors or higher, the baseline equipment is assumed to be a standard-efficiency air cooled heat pump roof top unit (RTU) system. For residential buildings types which utilize individual in-unit HVAC systems, such as multifamily, lodging, dormitories, etc., the baseline equipment is assumed to be a residential style standard-efficiency packaged terminal heat pump split system.

##### Fuel switch measures:

To calculate savings with a gas or fuel heating baseline, the baseline equipment is assumed to be single zone furnace and air-conditioning units for non-residential buildings 25,000 square feet or fewer and is 3 floors or fewer. For non-residential buildings over 25,000 square feet or taller than 3 floors, the baseline equipment is assumed to be a packaged variable-air-volume (VAV) system with DX cooling and hot water reheat. For residential buildings types which utilize individual in-unit HVAC systems, such as multifamily, lodging, dormitories, etc., the baseline equipment is assumed to be a packaged terminal air conditioner (PTAC) with hot-water radiator heating. If the residential building is 4 stories or more, the baseline system will be a water source heat pump (WSHP) system with a boiler and cooling tower.

Standard efficiency implies equipment that complies with Code energy efficiency requirements (IECC or Code of Federal Regulations, whichever is higher) in effect on the date of equipment purchase (if date unknown, assume current Code minimum). The rating conditions for the baseline and efficient equipment efficiencies must be equivalent. Note: IECC 2018 is baseline for all New Construction permits from July 1, 2019, and if permit date unknown. Note: new Federal Standards affecting heat pumps become effective January 1, 2023.

##### Baseline selection:

The following table can be used to determine the appropriate baseline HVAC system type.

	Non-Fuel Switch	Fuel Switch
Multifamily or Lodging, 3 floors or fewer	Packaged Terminal Heat Pump	PTAC w/ Hot Water Radiator
Multifamily or Lodging, 4 floors or more	Packaged Terminal Heat Pump	Water Source Heat Pump with Cooling Tower and Natural Gas Boiler

	Non-Fuel Switch	Fuel Switch
Non-residential <25,000 SF and 3 floors or fewer	Ducted-Split System Heat Pump	Packaged Single Zone (Furnace) + Air Conditioner
Non-Residential >25,000 SF OR more than 3 floors	Heat Pump RTU	Packaged VAV RTU with Hot Water Reheat

**DEEMED LIFETIME OF EFFICIENT EQUIPMENT**

The expected measure life for VRF is 16 years<sup>1162</sup>.

**DEEMED MEASURE COST**

**Time of Sale:** For analysis, the incremental capital costs are summarized in the following table. Site specific cost data should be used where available.

Baseline System	Incremental Cost (\$/ton) <sup>1163</sup>
Packaged Terminal Heat Pump	\$610
Ducted Split System Heat Pump	\$860
Heat Pump RTU	\$130
PTAC w/ Hot Water Radiator	\$160
Water Source Heat Pump	\$0
Packaged Single Zone (Furnace) + Air Conditioner	\$835
Packaged VAV RTU with Hot Water Reheat	\$540

**LOADSHAPE**

Loadshape C05 – Commercial Electric Heating and Cooling

**COINCIDENCE FACTOR**

The summer peak coincidence factor for cooling is provided in two different ways below. The first is used to estimate peak savings during the utility peak hour and is most indicative of actual peak benefits. The second represents the *average* savings over the defined summer peak period and is presented so that savings can be bid into PJM’s capacity market. Both values provided are based on analysis of Itron eShape data for Missouri, calibrated to Illinois loads, supplied by Ameren.

$$CF_{SSP} = \text{Summer System Peak Coincidence Factor for Commercial cooling (during system peak hour)}$$

$$= 91.3\%^{1164}$$

<sup>1162</sup> Consistent with Residential air source heat pump measure and based on a 2016 DOE Rulemaking Technical Support document, as recommended in Guidehouse ‘ComEd Effective Useful Life Research Report’, May 2018.

<sup>1163</sup> Estimated measure incremental costs for PTHP, HP RTU and PTAC based other incremental costs and differences in installed cost from U.S. Energy Information Administration (EIA), Updated Buildings Sector Appliance and Equipment Costs and Efficiencies: <https://www.eia.gov/analysis/studies/buildings/equipcosts/pdf/full.pdf>. For Ducted Split HP, Packaged Single Zone Furnace + AC and Packaged VAV RTU is based on Mid-Atlantic Technical Reference Manual version 9, Variable Refrigerant Flow (VRF) Heat Pump Systems measure. Published October, 2019. Water-source HP systems estimated from data collected from manufacturers. Water-source heat pump systems were not very different compared to VRF systems.

<sup>1164</sup> Based on analysis of Itron eShape data for Missouri, calibrated to Illinois loads, supplied by Ameren. The AC load during the utility’s peak hour is divided by the maximum AC load during the year.

$$CF_{PJM} = \text{PJM Summer Peak Coincidence Factor for Commercial cooling (average during peak period)}$$

$$= 47.8\%^{1165}$$

### Algorithm

#### CALCULATION OF ENERGY SAVINGS

##### ELECTRIC ENERGY SAVINGS

Savings are calculated as a sum of system switching savings and efficiency savings, analogous to the following equation:

$$\text{Annual Savings} = [\text{System Switch Savings}] + [\text{Savings from improved VRF efficiency}]$$

For fuel-switching calculations, the above equation is used for calculating the cooling savings, while the heating savings are calculated by as the following:

$$\begin{aligned} \text{Annual Savings} = & [\text{Gas Heat Replaced} \times \text{System Switch Adjustment Factor}] + [\text{Fan Savings}] - [\text{Heat Pump heat} \\ & \text{consumed} \times \text{System Switch Adjustment Factor}] + [\text{Heat Pump Cooling} * \text{System Switch Savings} + \\ & \text{Heat Pump Cooling Savings from improved VRF efficiency}] \end{aligned}$$

The system switching savings are calculated by multiplying the cooling or heating load (EFLH times heat or cool capacity) and multiplying it by system heating ( $Heat_{adj}$ ) and cooling ( $Cool_{adj}$ ) factors. These adjustment factors were calculated with energy model data of different building types. The VRF performance curves were calibrated based on independent field monitored data.

- The difference in building code baseline efficiency between VRF and the baseline system.
- The improved part load performance of the VRF inverter driven compressor compared to single-stage or two-stage compressors.
- Heat recovery mode savings from the VRF units.
- Decrease in energy from cooling towers (WSHP baseline) and water pumps (baseline systems with hot water and WSHP).
- WSHP electric heating and boiler fuel consumption (WSHP baseline).
- Differences in treating ventilation between mixed recirculating systems and VRF systems with dedicated outdoor air systems (Heat Pump RTU and VAV baseline systems only).

Savings from improved VRF efficiency is similar to other efficiency savings from other TRM measures, where savings are calculated as the load multiplied by the change in efficiency.

##### Non-fuel switch measures:

For units with cooling capacities less than 65 kBtu/hr:

$$\begin{aligned} \Delta kWh &= \text{Annual kWh Savings}_{\text{cool}} + \text{Annual kWh Savings}_{\text{heat}} + \text{FanSavings} \\ \text{Annual kWh Savings}_{\text{cool}} &= [\text{System Switch Savings}] + [\text{Savings from improved VRF efficiency}] \\ &= (\text{Cool}_{adj} * \text{Capacity}_{\text{cool}} * \text{EFLH}_{\text{cool}} / 3,412) + (\text{Capacity}_{\text{cool}} * \text{EFLH}_{\text{cool}} * \\ & \quad (1/\text{SEER}_{\text{base}} - 1/\text{SEER}_{\text{ee}})) / 1000 \\ \text{Annual kWh Savings}_{\text{heat}} &= [\text{System Switch Savings}] + [\text{Savings from improved VRF efficiency}] \\ &= (\text{Heat}_{adj} * \text{HeatLoad} / 3,412) + (\text{HeatLoad} * (1/\text{HSPF}_{\text{base}} - 1/\text{HSPF}_{\text{ee}})) / 1000 \\ \text{FanSavings} &= (\text{Flag} * \text{HeatLoad} * 1/\text{AFUE}_{\text{base}} * F_e) / 3,412 \end{aligned}$$

<sup>1165</sup> Based on analysis of Itron eShape data for Missouri, calibrated to Illinois loads, supplied by Ameren. The average AC load over the PJM peak period (1-5pm, M-F, June through August) is divided by the maximum AC load during the year.



For units with cooling capacities equal to or greater than 65 kBtu/hr:

$$\begin{aligned} \Delta kWh &= \text{Annual kWh Savings}_{\text{cool}} + \text{Annual kWh Savings}_{\text{heat}} + \text{FanSavings} \\ \text{Annual kWh Savings}_{\text{cool}} &= [\text{System Switch Savings}] + [\text{Savings from improved VRF efficiency}] \\ &= (\text{Cool}_{\text{adj}} * \text{Capacity}_{\text{cool}} * \text{EFLH}_{\text{cool}}/3,412) + (\text{Capacity}_{\text{cool}} * \text{EFLH}_{\text{cool}} * (1/\text{EER}_{\text{base}} - 1/\text{EER}_{\text{ee}}))/1000 \\ \text{Annual kWh Savings}_{\text{heat}} &= [\text{System Switch Savings}] + [\text{Savings from improved VRF efficiency}] \\ &= (\text{Heat}_{\text{adj}} * \text{HeatLoad})/3,412 + (\text{HeatLoad} * (1/\text{COP}_{\text{base}} - 1/\text{COP}_{\text{ee}})) / 3,412 \\ \text{FanSavings} &= (\text{Flag} * \text{HeatLoad} * 1/\text{AFUE}_{\text{base}} * F_e) / 3,412 \end{aligned}$$

Fuel switch measures:

Fuel switch measures must produce positive total lifecycle site energy savings in order to qualify. This is determined as follows (note for early replacement measures the lifetime savings should be calculated by calculating savings for the remaining useful life of the existing equipment and for the remaining measure life):

$$\begin{aligned} \text{SiteEnergySavings (MMBTU)} &= \text{GasHeatReplaced} + \text{FanSavings} - \text{HPSiteHeatConsumed} + \text{HPSiteCoolingImpact} \\ \text{GasHeatReplaced (MMBTU)} &= (\text{GasHeat}_{\text{adj}} * \text{HeatLoad} * 1/\text{AFUE}_{\text{base}}) / 1,000,000 \\ \text{FanSavings (MMBTU)} &= (\text{Flag} * \text{HeatLoad} * 1/\text{AFUE}_{\text{base}} * F_e) / 1,000,000 \end{aligned}$$

For units with cooling capacities less than 65 kBtu/hr:

$$\begin{aligned} \text{HPSiteHeatConsumed (MMBTU)} &= (\text{Heat}_{\text{adj}} * \text{HeatLoad} * (1/\text{HSPFee})) * 3,412 / 1,000 / 1,000,000 \\ \text{HPSiteCoolingImpact (MMBTU)} &= [\text{System Switch Savings}] + [\text{Savings from improved VRF efficiency}] \\ &= ((\text{Cool}_{\text{adj}} * \text{Capacity}_{\text{cool}} * \text{EFLH}_{\text{cool}}) / 1,000,000) + ((\text{EFLH}_{\text{cool}} * \text{Capacity}_{\text{cool}} * (1/\text{SEER}_{\text{base}} - 1/\text{SEER}_{\text{ee}})) * 3,412 / 1,000 / 1,000,000) \end{aligned}$$

For units with cooling capacities greater than 65 kBtu/hr:

$$\begin{aligned} \text{HPSiteHeatConsumed (MMBTU)} &= (\text{Heat}_{\text{adj}} * \text{HeatLoad} * (1/\text{COP}_{\text{ee}})) / 1,000,000 \\ \text{HPSiteCoolingImpact (MMBTU)} &= [\text{System Switch Savings}] + [\text{Savings from improved VRF efficiency}] \\ &= ((\text{Cool}_{\text{adj}} * \text{Capacity}_{\text{cool}} * \text{EFLH}_{\text{cool}}) / 1,000,000) + ((\text{EFLH}_{\text{cool}} * \text{Capacity}_{\text{cool}} * (1/\text{EER}_{\text{base}} - 1/\text{EER}_{\text{ee}})) * 3,412 / 1,000 / 1,000,000) \end{aligned}$$

Savings are adjusted by heating (Heat<sub>adj</sub>) and cooling (Cool<sub>adj</sub>) factors presented in the following table. These values bring the expected savings in line with energy model estimated savings.

Baseline System	GasHeat <sub>adj</sub>	Cool <sub>adj</sub>	Heat <sub>adj</sub>
Packaged Terminal Heat Pump	N/A	0.1	0.0
Ducted Split System Heat Pump	N/A	0.0	0.0
Heat Pump RTU	N/A	-0.2	0.5
PTAC w/ Hot Water Radiator	0.7	0.0	1.3

Baseline System	GasHeat <sub>adj</sub>	Cool <sub>adj</sub>	Heat <sub>adj</sub>
Water Source Heat Pump	0.4	0.1	0.5
Packaged Single Zone (Furnace) + Air Conditioner	1.4	0	1.6
Packaged VAV RTU with Hot Water Reheat	0.9	-0.2	1.8

If SiteEnergySavings calculated above is positive, the measure is eligible. The appropriate savings claim is dependent on which utilities are supporting the measure as provided in a table below:

Measure supported by:	Electric Utility claims (kWh):	Gas Utility claims (therms):
Electric utility only	SiteEnergySavings * 1,000,000/3,412	N/A
Electric and gas utility (Note: utilities may make alternative agreements to how savings are allocated as long as total MMBtu savings remains the same).	%IncentiveElectric * SiteEnergySavings * 1,000,000/3,412	%IncentiveGas * SiteEnergySavings * 10
Gas utility only	N/A	SiteEnergySavings * 10

Where:

Cool<sub>adj</sub> = This cooling adjustment factor is derived from energy modeling results to calibrate TRM calculation savings to energy modeling savings estimates.<sup>1166</sup> Adjustment factor values are presented in a table above.

Heat<sub>adj</sub> = This heating adjustment factor is derived from energy modeling results to calibrate TRM calculation savings to energy modeling savings estimates.<sup>1167</sup> Adjustment factor values are presented in a table above.

GasHeat<sub>adj</sub> = This gas heating adjustment factor is derived from energy modeling results to calibrate TRM calculation savings to energy modeling savings estimates.<sup>1168</sup> Adjustment factor values are presented in a table above.

Capacity<sub>cool</sub> = input capacity of the cooling equipment in Btu per hour (1 ton of cooling capacity equals 12,000 Btu/hr).  
= Actual installed

SEER<sub>base</sub> = Seasonal Energy Efficiency Ratio of the baseline equipment  
= SEER from tables below, based on the applicable Code on the date of equipment purchase (if unknown assume current Code).

SEER<sub>ee</sub> = Seasonal Energy Efficiency Ratio of the energy efficient equipment.  
= Actual installed

EFLH<sub>cool</sub> = Equivalent Full Load Hours for cooling in Existing Buildings or New Construction are provided in section 4.4 HVAC End Use.

HSPF<sub>base</sub> = Heating Seasonal Performance Factor of the baseline equipment  
= HSPF from tables below, based on the applicable Code on the date of equipment purchase (if unknown assume current Code).

<sup>1166</sup> Based on Variable Refrigerant Flow Study. See 'Variable Refrigerant Flow Study 2023'.

<sup>1167</sup> Based on Variable Refrigerant Flow Study. See 'Variable Refrigerant Flow Study 2023'.

<sup>1168</sup> Based on Variable Refrigerant Flow Study. See 'Variable Refrigerant Flow Study 2023'.

- HSPFee = Heating Seasonal Performance Factor of the energy efficient equipment.  
 = Actual installed. If rating is COP,  $HSPF = COP * 3.413$
- EERbase = Energy Efficiency Ratio of the baseline equipment  
 = EER from tables below, based on the applicable Code on the date of equipment purchase (if unknown assume current Code). For air-cooled units < 65 kBtu/hr, assume the following conversion from SEER to EER for calculation of peak savings<sup>1169</sup>:  
 $EER = (-0.02 * SEER_2) + (1.12 * SEER)$
- EERee = Energy Efficiency Ratio of the energy efficient equipment. For air-cooled units < 65 kBtu/hr, if the actual EERee is unknown, assume the conversion from SEER to EER as provided above.  
 = Actual installed
- HeatLoad = Calculated heat load for the building  
 =  $EFLH_{heat} * Capacity_{heat}$   
 Where:  
 $EFLH_{heat}$  = heating mode equivalent full load hours in Existing Buildings or New Construction are provided in section 4.4 HVAC End Use.  
 $Capacity_{heat}$  = Actual installed input capacity of the heat pump equipment in Btu per hour.
- 3412 = Btu per kWh.
- COPbase = coefficient of performance of the baseline equipment  
 = COP from tables below, based on the applicable Code on the date of equipment purchase (if unknown assume current Code).  
 If rating is HSPF,  $COP = HSPF / 3.413$
- COPee = coefficient of performance of the energy efficient equipment.  
 = Actual installed. If rating is HSPF,  $COP = HSPF / 3.413$
- AFUEbase = Baseline Annual Fuel Utilization Efficiency Rating. Use appropriate code level efficiency.
- Flag = 1 if system replaced is an RTU or ducted system with furnace fan, 0 if not.
- Fe = Fan energy consumption as a percentage of annual fuel consumption  
 = 7.7% for RTU replacement, 3% for multifamily (residential style) furnace replacement<sup>1170</sup>
- %IncentiveElectric = % of total incentive paid by electric utility  
 = Actual
- %IncentiveGas = % of total incentive paid by gas utility  
 = Actual

---

<sup>1169</sup> Based on Wassmer, M. (2003). A Component-Based Model for Residential Air Conditioner and Heat Pump Energy Calculations. Masters Thesis, University of Colorado at Boulder. Note this is appropriate for single speed units only.

<sup>1170</sup> Fe is estimated using TRM models for the three building types: low-rise office, sit-down restaurant and retail-strip mall. 7.7% represents the average Fe of the three building types. See "Fan Energy Factory Example Calculation 2021-06-23.xlsx" for reference. Mutlfamily is 3%, lower than commercial, due to typically lower fan static pressure in residential style applications.

Equipment Type	Size Category	Heating Section Type	Subcategory or Rating Condition	Minimum Efficiency	Test Procedure
VRF air cooled (cooling mode)	<65,000 Btu/h	All  <i>Electric resistance</i> (or none)	VRF multisplit system	13.0 SEER	AHRI 1230
				11.0 EER 12.9 IEER 14.6 IEER	
	VRF multisplit system with heat recovery		10.8 EER 12.7 IEER 14.4 IEER		
	≥135,000 Btu/h and <240,000 Btu/h		VRF multisplit system	10.6 EER 12.3 IEER 13.9 IEER	
			VRF multisplit system with heat recovery	10.4 EER 12.1 IEER 13.7 IEER	
	≥240,000 Btu/h		VRF multisplit system	9.5 EER 11.0 IEER 12.7 IEER	
VRF air cooled (heating mode)	<65,000 Btu/h (cooling capacity)	VRF multisplit system	7.7 HSPF	AHRI 1230	
		VRF multisplit system 47°F db/43°F wb outdoor air	3.3 COP <sub>H</sub>		
	17°F db/15°F wb outdoor air	2.25 COP <sub>H</sub>			
	≥135,000 Btu/h (cooling capacity)	VRF multisplit system 47°F db/43°F wb outdoor air	3.2 COP <sub>H</sub>		
		17°F db/15°F wb outdoor air	2.05 COP <sub>H</sub>		

**Non Fuel Switch example**, a heat recovery VRF system with 8 ton cooling capacity and 96 kbtu heating capacity, an efficient EER of 12.5 and COP of 3.75, at a new construction low-rise office in Chicago saves:

$$\Delta kWh = \text{Annual kWh Savings}_{\text{cool}} + \text{Annual kWh Savings}_{\text{heat}} + \text{FanSavings}$$

$$\text{Annual kWh Savings}_{\text{cool}} = (\text{Cooladj} * \text{Capacity}_{\text{cool}} * \text{EFLH}_{\text{cool}} / 3412) + (\text{Capacity}_{\text{cool}} * \text{EFLH}_{\text{cool}} * (1/\text{EER}_{\text{base}} - 1/\text{EER}_{\text{ee}}))/1000$$

$$\text{Annual kWh Savings}_{\text{heat}} = (\text{Heatadj} * \text{Heat Load} / 3412) + (\text{HeatLoad} * (1/\text{COP}_{\text{base}} - 1/(\text{COP}_{\text{ee}})))/3412$$

$$\text{FanSavings} = (\text{Flag} * \text{HeatLoad} * 1/\text{AFUE}_{\text{base}} * \text{Fe}) / 3412$$

$$\Delta kWh = (0.0 * 96000 * 989/3,412) + (96000 * 989 * (1/10.8 - 1/12.5))/1000 + (0.0 * 916 * 60000/3412) + (916 * 60000 * (1/3.3 - 1/3.75) / 3412) + (1 * 916 * 60000 * 1/0.8 * 0.077) / 3412$$

$$\Delta kWh = 3332 \text{ kWh}$$

**Fuel Switch example**, a heat recovery VRF system with 8-ton cooling capacity and 96 kbtu heating capacity, an efficient EER of 12.5 and COP of 3.75, at a new construction low-rise office in Chicago, assuming a packaged single zone (furnace) and air conditioner baseline. Assuming 50%-50% Incentive agreement is used for joint programs, savings:

$$\text{SiteEnergySavings (MMBTUs)} = \text{GasHeatReplaced} + \text{FanSavings} - \text{HPSiteHeatConsumed} + \text{HPSiteCoolingImpact}$$

$$\begin{aligned} \text{GasHeatReplaced} &= (\text{GasHeat}_{\text{adj}} * \text{HeatLoad} * 1/\text{AFUE}_{\text{base}}) / 1,000,000 \\ &= 1.4 * (96000 * 916 * 1/0.8) / 1000000 \\ &= 153.9 \text{ MMBtu} \end{aligned}$$

$$\begin{aligned} \text{FanSavings} &= (\text{Flag} * \text{HeatLoad} * 1/\text{AFUE}_{\text{base}} * F_e) / 1,000,000 \\ &= (1 * 96000 * 916 * 1/0.8 * 0.030) / 1000000 \\ &= 3.30 \text{ MMBtu} \end{aligned}$$

For units with cooling capacities greater than 65 kBtu/hr:

$$\begin{aligned} \text{HPSiteHeatConsumed} &= (\text{Heat}_{\text{adj}} * \text{HeatLoad} * (1/\text{COPE})) / 1,000,000 \\ &= (1.6 * 96000 * 916 * (1/3.75)) / 1,000,000 \\ &= 37.9 \text{ MMBtu} \end{aligned}$$

$$\begin{aligned} \text{HPSiteCoolingImpact} &= (\text{Cool}_{\text{adj}} * \text{Capacity}_{\text{cool}} * \text{EFLH}_{\text{cool}} / 1,000,000) * (\text{FLH}_{\text{cool}} * \text{Capacity}_{\text{cool}} * \\ &\quad (1/\text{EER}_{\text{base}} - 1/\text{EER}_{\text{ee}})) * 3,412 / 1,000 / 1,000,000 \\ &= ((0.0 * 989 * 96000)/1,000,000) + (989 * 96000 * (1/10.8-1/12.5)) * 3,412 \\ &\quad / 1,000 / 1,000,000 \\ &= 4.1 \text{ MMBtu} \end{aligned}$$

$$\text{SiteEnergySavings (MMBTUs)} = 153.9 + 3.30 - 37.9 + 4.1 = 123.3 \text{ [Measure is eligible]}$$

Savings would be claimed as follows, assuming a 50%-50% incentive agreement:

Measure supported by:	Electric Utility claims (kWh):	Gas Utility claims (therms):
Electric utility only	$123.3 * 1,000,000/3,412$ = 36,148 kWh	N/A
Electric and gas utility (Note utilities may make alternative agreements to how savings are allocated as long as total MMBtu savings remains the same).	$0.5 * 123.3 * 1,000,000/3,412$ = 18,074 kWh	$0.5 * 88.9 * 10$ = 617 therms
Gas utility only	N/A	$123.3 * 10$ = 1,233 therms

**SUMMER COINCIDENT PEAK DEMAND SAVINGS**

$$\Delta \text{kW} = (\text{Capacity}_{\text{cool}} / 1,000 * (1/\text{EER}_{\text{base}} - 1/\text{EER}_{\text{ee}})) * \text{CF}$$

Where CF value is chosen between:

$$\begin{aligned} \text{CF}_{\text{SSP}} &= \text{Summer System Peak Coincidence Factor for Commercial cooling (during system peak hour)} \\ &= 91.3\% \end{aligned}$$

$$CF_{PJM} = \text{PJM Summer Peak Coincidence Factor for Commercial cooling (average during peak period)}$$

$$= 47.8\%$$

**For example**, a heat recovery VRF system with 8-ton cooling capacity and 96 kbtu heating capacity, an efficient EER of 12.5, saves:

$$\Delta kW = (96000/1000 * (1/10.8 - 1/12.5)) * 0.913$$

$$= 1.1 \text{ kW}$$

**FOSSIL FUEL SAVINGS**

Calculation provided together with Electric Energy Savings above.

**WATER AND OTHER NON-ENERGY IMPACT DESCRIPTIONS AND CALCULATION**

N/A

**DEEMED O&M COST ADJUSTMENT CALCULATION**

N/A

**COST EFFECTIVENESS SCREENING AND LOAD REDUCTION FORECASTING WHEN FUEL SWITCHING**

This measure can involve fuel switching from gas to electric.

For the purposes of forecasting load reductions due to fuel switch ASHP projects per Section 16-111.5B, changes in site energy use at the customer’s meter (using ΔkWh algorithm below), customer switching estimates, NTG, and any other adjustment factors deemed appropriate, should be used.

The inputs to cost effectiveness screening should reflect the actual impacts on the electric and fuel consumption at the customer meter and, for fuel switching measures, should therefore reflect the decrease in one fuel and increase in another, as opposed to the single savings value calculated in the “Electric and Fossil Fuel Energy Savings” section above. Therefore in addition to the calculation of savings claimed, the following values should be used to assess the cost effectiveness of the measure.

$$\Delta \text{Therms} = [\text{Heating Consumption Replaced}]$$

$$= [\text{GasHeat}_{Adj} * \text{HeatLoad} * 1/\text{AFUE}_{base}] / 100,000]$$

$$\Delta \text{kWh} = [\text{FurnaceFanSavings}] - [\text{HP heating consumption}] + [\text{Cooling savings}]$$

For units with cooling capacities less than 65 kBtu/hr:

$$\Delta \text{kWh} = [\text{FurnaceFlag} * \text{HeatLoad} * 1/\text{AFUE}_{base} * F_e * 0.000293] - [\text{Heat}_{Adj} * \text{HeatLoad}/3412 * (1/(\text{CO}_{Pee}))/1000] + [\text{Cool}_{adj} * (\text{Capacity}_{cool} * \text{EFLH}_{cool} * (1/\text{EER}_{base} - 1/\text{EER}_{ee}))/1000]$$

For units with cooling capacities greater than 65 kBtu/hr:

$$\Delta \text{kWh} = [\text{FurnaceFlag} * \text{HeatLoad} * 1/\text{AFUE}_{base} * F_e * 0.000293] - [\text{Heat}_{adj} * \text{HeatLoad}/3412 * (1/\text{CO}_{Pee})] + [\text{Cool}_{adj} * (\text{Capacity}_{cool} * \text{EFLH}_{cool} * (1/\text{EER}_{base} - 1/\text{EER}_{ee}))/1000]$$

**MEASURE CODE: CI-HVC-VFFY-V3-240101**

**REVIEW DEADLINE: 1/1/2026**

### 4.4.61 Chiller Condenser Water Temperature Reset

**DESCRIPTION**

Condenser water temperature reset – reset the constant condensing loop supply temperature from constant 80°F to a dynamic range of 70°F to 80°F based on the outdoor-air wet-bulb temperature (WBT). When the outdoor-air wet-bulb temperature is below 60°F, reset the condensing loop set point to 70°F. When the outdoor-air wet-bulb temperature is above 70°F, reset to 80°F; when the outdoor-air wet-bulb temperature is in between, reset the condensing supply temperature to 10°F higher than the outdoor-air wet-bulb temperature. The chiller COP (coefficient of performance) increases after the measure is applied. However, the condenser loop balances out the energy saving because the cooling tower fan works harder and longer to cool condensing water to a lower temperature. The resulting savings (primarily cooling) from this measure are roughly proportional to the amount of part-load cooling that is required in the baseline and range between 0.1% and 1.3%.

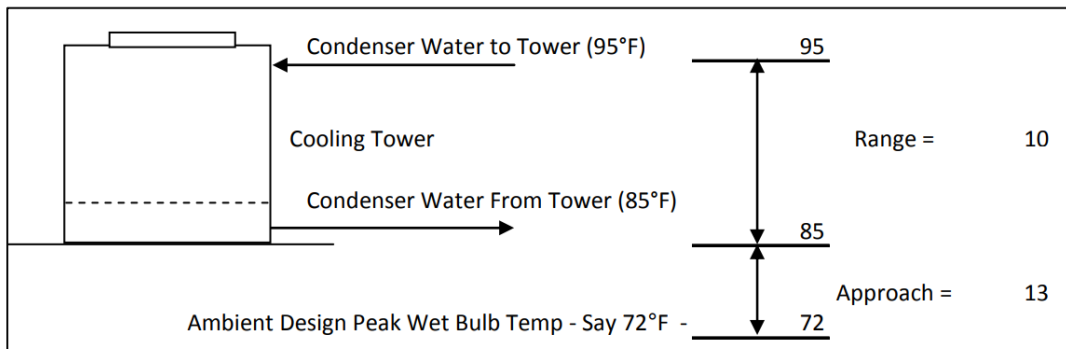

**DEFINITION OF EFFICIENT EQUIPMENT**

This measure is applicable when the condenser water temperature (CWT) setpoint is either not resetting properly, or a reset strategy is not implemented. The minimum setpoint is set to 70°F.

**DEFINITION OF BASELINE EQUIPMENT**

The baseline condition is fixed condenser water temperature of 85°F. Only applicable to water-cooled chillers.

Baseline Data Collection:

- Trend Current outdoor air dry bulb and wet bulb temperatures
- Trend Current entering condenser water supply temperature
- Trend Current leaving chilled water temperature

**DEEMED LIFETIME OF EFFICIENT EQUIPMENT**

The expected lifetime of the measure is 10 years<sup>1171</sup>

**DEEMED MEASURE COST**

Use actual chiller manufacturer provided cost.

**LOADSHAPE**

Loadshape C03 - Commercial Cooling

<sup>1171</sup> 2008 Database for Energy-Efficiency Resources (DEER), Version 2008.2.05, "Effective/Remaining Useful Life Values", California Public Utilities Commission, December 16, 2008



**COINCIDENCE FACTOR**

$CF_{SSP}$  = Summer System Peak Coincidence Factor for Commercial cooling (during system peak hour)  
 = 91.3%<sup>1172</sup>

$CF_{PJM}$  = PJM Summer Peak Coincidence Factor for Commercial cooling (average during peak period)  
 = 47.8%<sup>1173</sup>

---

**Algorithm**

---

**CALCULATION OF ENERGY SAVINGS**

Efficient Data Collection:

- 1 Trend outdoor air dry bulb and wet bulb temperatures
- 2 Trend entering condenser water supply temperature
- 3 Trend leaving chilled water temperature
- 4 Trend energy usage (kWh)
- 5 Model weather bin data
- 6 Trend condenser water supply temperature and temperature setpoint, and whatever parameter the reset is based on (e.g., outside air dry bulb and wet bulb temperatures).
- 7 Perform functional testing if independent variables at the time of trending do not cover the range covered by the reset.

**ELECTRIC ENERGY SAVINGS**

$$\Delta kWh = TONS * ((IPLV_{base}) - (CPLV_{ee})) * EFLH$$

Where:

- TONS** = Chiller nominal cooling capacity in tons (note: 1 ton = 12,000 Btu/hr)  
 = Actual installed
- IPLV<sub>base</sub>** = Efficiency of baseline equipment expressed as Integrated Part Load Value(kW/ton). Chiller units are dependent on chiller type. See Chiller Units, Conversion Values and Baseline Efficiency Values by Chiller Type and Capacity in the Reference Tables section.
- CPLV<sub>ee</sub>** = Calculated Part Load Value based on trend data post measure install (kW/ton)  
 = Actual installed
- EFLH<sup>1174</sup>** = Equivalent Full Load Hours for cooling in Existing Buildings or New Construction are provided in section 4.4 HVAC End Use.

---

<sup>1172</sup> Based on analysis of Itron eShape data for Missouri, calibrated to Illinois loads, supplied by Ameren. The AC load during the utility’s peak hour is divided by the maximum AC load during the year.

<sup>1173</sup> Based on analysis of Itron eShape data for Missouri, calibrated to Illinois loads, supplied by Ameren. The average AC load over the PJM peak period (1-5pm, M-F, June through August) is divided by the maximum AC load during the year.

<sup>1174</sup> “2022 Illinois Statewide Technical Reference Manual for Energy Efficiency Version 10.0; Volume 2: Commercial and Industrial Measures; 4.4. HVAC End Use”, Sept 2021, [https://ilsag.s3.amazonaws.com/IL-TRM\\_Effective\\_010122\\_v10.0\\_Vol\\_2\\_C\\_and\\_I\\_09242021.pdf](https://ilsag.s3.amazonaws.com/IL-TRM_Effective_010122_v10.0_Vol_2_C_and_I_09242021.pdf)

### **SUMMER COINCIDENT PEAK DEMAND SAVINGS**

$$\Delta kW_{SSP} = \text{TONS} * ((PE_{base}) - (PE_{ee})) * CF_{SSP}$$

$$\Delta kW_{PJM} = \text{TONS} * ((PE_{base}) - (PE_{ee})) * CF_{PJM}$$

Where:

$PE_{base}$  = Peak efficiency of baseline equipment expressed as Full Load (kW/ton)

$PE_{ee}$  = Peak efficiency of high efficiency equipment expressed as Full Load (kW/ton)

= Actual installed

$CF_{SSP}$  = Summer System Peak Coincidence Factor for Commercial cooling (during system peak hour)

= 91.3%

$CF_{PJM}$  = PJM Summer Peak Coincidence Factor for Commercial cooling (average during peak period)

= 47.8%

### **FOSSIL FUEL SAVINGS**

N/A

### **WATER AND OTHER NON-ENERGY IMPACT DESCRIPTIONS AND CALCULATION**

N/A

### **DEEMED O&M COST ADJUSTMENT CALCULATION**

There are no expected O&M costs or savings associated with this measure.

**MEASURE CODE: CI-HVC-CWTR-V1-230101**

**REVIEW DEADLINE: 1/1/2025**

## 4.4.62 Cooling Tower Water Side Economizer

### DESCRIPTION

A waterside economizer works by running the cooling tower loop in the winter and parts of the shoulder seasons as a source of cooling and transferring cooling energy to the building (secondary) cooling loop. This requires a dedicated plate-and-frame heat exchanger that is used only during waterside economizer operations, during which time the chillers are locked out.

A waterside economizer may contribute to reduced energy use in the following ways:

- Reducing the mechanical cooling load on chillers by precooling return water
- Reducing energy use of the plant by allowing chillers to turn off at times of free cooling

Energy consumption (kWh) may decrease with the use of a waterside economizer because the leaving chilled water temperature can be reduced based on the wet bulb temperature. With this control strategy, the effect will be a reduction in motor speed (rpms) of the compressor as well as the pre-cooling of the chilled water return through the waterside economizer.

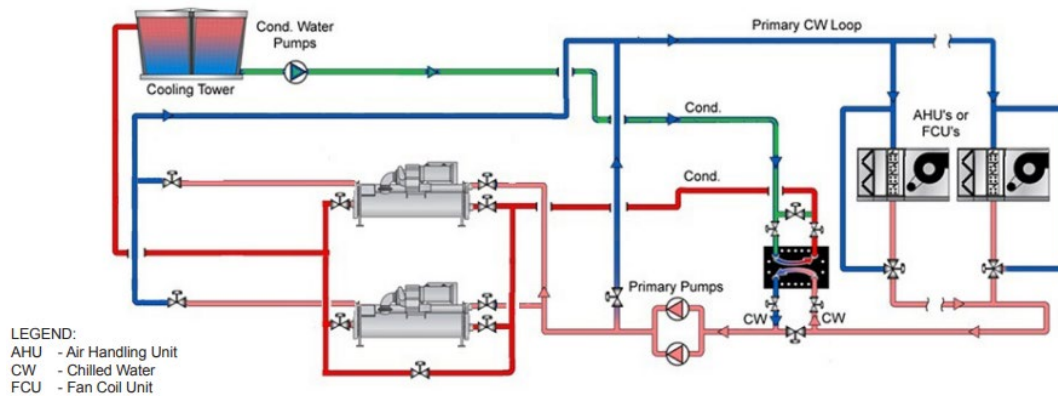

### DEFINITION OF EFFICIENT EQUIPMENT

Installation of integrated waterside economizer heat exchanger to existing chilled-water system with cooling tower. Heat exchanger approach may range from 1° to 6° Definition of Baseline Equipment. Weather data is used to identify the annual hours in which outdoor air conditions are sufficient to provide water at a desirable temperature. Typically, demand savings may not be present with this measure because the process systems require water temperatures around 55-65°F and a cooling tower cannot meet these temperatures during the peak period.

### DEFINITION OF BASELINE EQUIPMENT

No waterside heat exchanger install or functional.

### DEEMED LIFETIME OF EFFICIENT EQUIPMENT

The expected lifetime of the measure is 10 years<sup>1175</sup>

### DEEMED MEASURE COST

Use actual chiller manufacturer provided cost.

<sup>1175</sup> (2008 Database for Energy-Efficiency Resources (DEER), Version 2008.2.05, "Effective/Remaining Useful Life Values", California Public Utilities Commission, December 16, 2008)

**LOADSHAPE**

Loadshape C03 - Commercial Cooling

**COINCIDENCE FACTOR**

CF<sub>SSP</sub> = Summer System Peak Coincidence Factor for Commercial cooling (during system peak hour)  
 = 91.3%<sup>1176</sup>

CF<sub>PJM</sub> = PJM Summer Peak Coincidence Factor for Commercial cooling (average during peak period)  
 = 47.8%<sup>1177</sup>

---



---

**Algorithm**

---



---

**CALCULATION OF ENERGY SAVINGS**

**ELECTRIC ENERGY SAVINGS**

$$\Delta kWh = TONS * IPLV_{base} * (Hr)_{Free}$$

Where:

TONS = chiller nominal cooling capacity in tons (note: 1 ton = 12,000 Btu/hr)  
 = Actual installed

IPLV<sub>base</sub> = efficiency of baseline equipment expressed as Integrated Part Load Value (kW/ton). Chiller units are dependent on chiller type. See Chiller Units, Conversion Values and Baseline Efficiency Values by Chiller Type and Capacity in the Reference Tables section.  
 = Actual installed

(Hr)<sub>Free</sub> = Annual hours in which outdoor air conditions are sufficient to provide condenser water at a desirable temperature that the chiller does not need to operate.

**SUMMER COINCIDENT PEAK DEMAND SAVINGS**

N/A

**FOSSIL FUEL SAVINGS**

N/A

**WATER AND OTHER NON-ENERGY IMPACT DESCRIPTIONS AND CALCULATION**

N/A

**DEEMED O&M COST ADJUSTMENT CALCULATION**

There are no expected O&M costs or savings associated with this measure.

**MEASURE CODE: CI-HVC-CTWE-V1-230101**

**REVIEW DEADLINE: 1/1/2025**

---

<sup>1176</sup> Based on analysis of Itron eShape data for Missouri, calibrated to Illinois loads, supplied by Ameren. The AC load during the utility’s peak hour is divided by the maximum AC load during the year.

<sup>1177</sup> Based on analysis of Itron eShape data for Missouri, calibrated to Illinois loads, supplied by Ameren. The average AC load over the PJM peak period (1-5pm, M-F, June through August) is divided by the maximum AC load during the year.

## 4.4.63 Boiler Blowdown Heat Recovery

### DESCRIPTION

This measure is for a non-residential steam boiler serving process load or space heating. The measure applies to steam natural gas fired boilers where the continuous blowdown exceeds 5% of the steam rate<sup>1178</sup>. Blowdown heat recovery systems should also be considered when about 500lbs/hr of steam is blown down and for continuous blowdown systems of at least 1 gpm<sup>1179</sup>. All steam boilers must blow down to reduce the amount of dissolved solids in the boiler water. However, along with the solids, boiler chemicals and thermal energy is lost. Although blowdown heat recovery systems cannot recover the chemicals, they do recover up to 90% of the heat energy that would otherwise be lost down the drain<sup>1180</sup>. Blowdown waste heat can be recovered with a heat exchanger, a flash tank, or a flash tank in a combination with a heat exchanger. The recovered heat is used to pre-heat boiler make-up water before it enters the deaerator, and for low pressure steam to heat water inside the deaerator, which improves overall boiler efficiency. Heat can be recovered from boiler blowdown by using a heat exchanger to preheat boiler makeup water. Additionally, changing from manual blowdown control to automatic control can reduce a boiler's energy use by 2 – 5 percent and reduce blowdown water losses by up to 20 percent.<sup>1181</sup>

The measure is applicable to commercial applications, commercial HVAC including multifamily buildings, low pressure applications, medium pressure industrial applications and high pressure applications. It was developed to be applicable to the following program types: TOS, RF. If applied to other program types, the measure savings should be verified.

### DEFINITION OF EFFICIENT EQUIPMENT

The efficient equipment is defined as a functional steam boiler with a blowdown heat recovery system that increases the heat recovery and boiler efficiencies in comparison to the baseline case. New systems are not eligible for this measure.

### DEFINITION OF BASELINE EQUIPMENT

The baseline equipment is an existing steam boiler system with a deaerator where no blowdown heat is recovered

### DEEMED LIFETIME OF EFFICIENT EQUIPMENT

The expected measure life is assumed to be 20 years; capped at the measure life of a steam boiler.<sup>1182</sup>

---

<sup>1178</sup> "Boiler Blowdown – Fact Sheet" N.C Division of Pollution Prevention and Environmental Assistance, August 2004.  
<https://p2infohouse.org/ref/34/33027.pdf>,

<sup>1178</sup> "ASHRAE: HVAC Service Life Database" ASHRAE, last modified May 12, 2023,

<sup>1179</sup> "Blowdown Heat Recovery" Clean Boiler, 2005

<http://cleanboiler.org/learn-about/boiler-efficiency-improvement/efficiency-index/index-boiler-operations/blowdown-heat-recovery/#:~:text=A%20blowdown%20heat%20recovery%20system%20should%20be%20considered,Continuous%20blowdown%20systems%20of%20at%20least%201%20gpm>

<sup>1180</sup> "Recover Heat from Boiler Blowdown" Department of Energy, January 2012.

[https://www.energy.gov/sites/prod/files/2014/05/f16/steam10\\_boiler\\_blowdown.pdf](https://www.energy.gov/sites/prod/files/2014/05/f16/steam10_boiler_blowdown.pdf)

<sup>1181</sup> "Boiler Blowdown – Fact Sheet" N.C Division of Pollution Prevention and Environmental Assistance, last modified August 2004.

<https://p2infohouse.org/ref/34/33027.pdf>,

<sup>1182</sup> "ASHRAE: HVAC Service Life Database" ASHRAE, last modified May 12, 2023,

[http://weblegacy.ashrae.org/publicdatabase/service\\_life.asp](http://weblegacy.ashrae.org/publicdatabase/service_life.asp)

**DEEMED MEASURE COST**

If known, the actual material and labor cost of installation should be used. If unknown, the cost of this measure is estimated to be \$1.4/kBtu/hr<sup>1183</sup> per boiler. This cost includes material and labor for installing boiler blowdown heat recovery systems (i.e - storage tanks, pipes and pumps).

**LOADSHAPE**

N/A

**COINCIDENCE FACTOR**

For process boiler systems, the summer peak coincidence factor for this measure is dependent on the industrial shift and corresponding hours of operation. Values are provided for each shift type in the variable definition section.

N/A for space heating boiler systems.

---

**Algorithm**

---

**CALCULATION OF ENERGY SAVINGS**

**ELECTRIC ENERGY SAVINGS**

N/A

**SUMMER COINCIDENT PEAK DEMAND SAVINGS**

N/A

**NATURAL GAS SAVINGS**

Natural gas savings are calculated by estimating the amount of blowdown net heat flow. Savings are calculated from the enthalpy difference between the make-up water and the blowdown temperature.

$$\Delta\text{Therms} = \frac{\text{BFR} \times (H_B - H_w)}{n_{\text{boiler}} \times 100,000} \times \text{SF}$$

Where:

**BFR** = Boiler Blowdown flow rate in lb/year. The calculated blowdown flow rate is in turn used to calculate natural gas savings. Boiler heat recovery systems vary widely between manufacturers and facilities.

$$\text{BFR} = \text{Annual}_{\text{usage}} \times \% \text{BD}$$

**Annual<sub>usage</sub>** = The annual steam usage in lbm/year.

= Actual or if unknown:

$$\text{Annual}_{\text{usage}} = \left[ \frac{\text{Hours} \times \text{Capacity}}{[(H_S - H_B)(1 - \%_{\text{make-up}}) + (H_S - H_w)(\%_{\text{make-up}})]} \right]$$

**Capacity** = Boiler input capacity in btu/hr.

**%<sub>make-up</sub>** = Percentage of make-up water

---

<sup>1183</sup> Results from Blowdown Heat Recovery efficiency improvement research through the C&I and Public Sector Custom Rebate Program, and Small Business Program. The evaluation included project and population data from years 2018 – 2023.

= 20%<sup>1184</sup> or actual if known.

If space heating:

Hours = Equivalent Full Load Hours of heating in Existing Buildings; provided in section 4.4 HVAC End Use.

If process:

Hours = Annual Hours × UF

Annual Hours = Annual operating hours of the facility  
= Use actual or if unknown 8766<sup>1185</sup>

UF = Utilization Factor  
= Use actual or if unknown 41.9%<sup>1186</sup>

%BD = Blowdown Percentage  
= 5% for automatic or 7% for manual<sup>1187</sup> or:

$$\%BD = \frac{1}{C_{\text{cycle}}}$$

C<sub>cycle</sub> = Concentration cycles

$$C_{\text{cycle}} = \frac{F_c \times \text{cond}_{\text{target}}}{\text{cond}_{\text{feedwater}}}$$

= Actual if known

F<sub>c</sub> = Conductivity Factor  
= 1 if automatic blowdown; 1.2<sup>1188</sup> if manual blowdown

H<sub>B</sub> = Enthalpy of the blowdown (Btu/lbm)

System Type	Supply Fluid Temperature <sup>1189</sup> (°F)	Enthalpy of Blowdown (Btu/lbm)
5 psi Steam (low pressure)	225	195.4
15 psi Steam (low pressure)	250	218.3
40 psi Steam (low pressure)	287	256.1
65 psi Steam (high pressure)	312	281.9
100 psi Steam (high pressure)	338	309.1
150 psi Steam (high pressure)	365	338.6

<sup>1184</sup> Okbaendrias, Biniam. Energy Management in Industries: Analysis of energy savings potential by steam condensate return. Page 10. About 75-85% of the total condensate return in reasonable

<sup>1185</sup> From IL TRM

<sup>1186</sup> From IL TRM Measure 4.4.54 Process Heating Boiler

<sup>1187</sup> “Boiler Blowdown – Fact Sheet” N.C Division of Pollution Prevention and Environmental Assistance, August 2004. <https://p2infohouse.org/ref/34/33027.pdf>

<sup>1188</sup> “Boiler Blowdown – Fact Sheet” N.C Division of Pollution Prevention and Environmental Assistance, last modified August 2004.

<https://p2infohouse.org/ref/34/33027.pdf>

<sup>1189</sup> A typical design uses a Δ20°F from hot water supply temperature to return temperature. ASHRAE. Boiler System Efficiency. 2006. <http://goeshheatingsystems.com/wp-content/uploads/2015/04/BoilerEfficiencyArticle.pdf>

$H_s$  = Enthalpy of supplied steam<sup>1190</sup>, (Btu/lbm)

System Type	Supply Fluid Temperature <sup>1191</sup> (°F)	Enthalpy of Supplied Steam (Btu/lbm)
5 psi Steam (low pressure)	225	1155
15 psi Steam (low pressure)	250	1166
40 psi Steam (low pressure)	287	1176
65 psi Steam (high pressure)	312	1186
100 psi Steam (high pressure)	338	1190
150 psi Steam (high pressure)	365	1196

$H_w$  = Enthalpy of incoming water from well or municipal system (Btu/lbm)  
 = 18.8 Btu/lbm for incoming water temperature of 50.7°F<sup>1192</sup>

SF = 90% heat recovery<sup>1193</sup>.

$n_{boiler}$  = Efficiency of the steam boiler  
 = Actual or if unknown use default values given below:  
 = 80.7% for steam boilers, except multifamily low-pressure.<sup>1194</sup>  
 = 64.8% for multifamily low-pressure steam boilers.<sup>1195</sup>

$\%_{boiler\ load}$  = The load percentage of the blowdown boiler in the total load. (i.e if only one boiler available in the facility, use 1)

$Cond_{feed\ water}$  = The conductivity of the feed water in  $\mu\text{mho}$ .  
 = Actual, if known.  
 =  $(\%_{make-up}) \times cond_{make\ up} + (1 - \%_{make-up}) \times cond_{return}$

$Cond_{make\ up}$  = 317<sup>1196</sup>  $\mu\text{mho}$  or actual if known.

$Cond_{return}$  = 20  $\mu\text{mho}$ <sup>1197</sup> or actual if known.

<sup>1190</sup> Taken from IL TRM Measure 4.4.14 Pipe Insulation

<sup>1191</sup> A typical design uses a  $\Delta 20^\circ\text{F}$  from hot water supply temperature to return temperature. ASHRAE. Boiler System Efficiency. 2006. <http://goesheatingsystems.com/wp-content/uploads/2015/04/BoilerEfficiencyArticle.pdf>

<sup>1192</sup> Taken from IL TRM Measure 4.4.14 Pipe Insulation

<sup>1193</sup> "Recover Heat from Boiler Blowdown" Department of Energy, last modified May 12, 2023.

[https://www.energy.gov/sites/prod/files/2014/05/f16/steam10\\_boiler\\_blowdown.pdf](https://www.energy.gov/sites/prod/files/2014/05/f16/steam10_boiler_blowdown.pdf)

<sup>1194</sup> Ibid

<sup>1195</sup> Katrakis, J. and T.S. Zawacki. "Field-Measured Seasonal Efficiency of Intermediate-sized Low-Pressure Steam Boilers". ASHRAE V99, pt. 2, 1993.

<sup>1196</sup> "Comprehensive Chemical Analysis" City of Chicago – Department of Water Management – Bureau of Water Supply; Water Quality Division-Water Purification Laboratories, last modified May 12, 2023.

<https://www.chicago.gov/content/dam/city/depts/water/WaterQltyResultsNRpts/ccReports/CCA-2019-1-3.pdf>

<sup>1197</sup> "Boiler Blowdown Automation Basics", last modified January 23, 2017.

<https://www.yamathosupply.com/blogs/news/boiler-blowdown-automation-basics#:~:text=Involves%20manually%20opening%20a%20blowdown%20valve%20at%20various,target%20maximum%20lead%20to%20the%20formation%20of%20scale.>



Cond<sub>target</sub> = The target conductivity following blowdown in µmho<sup>1198</sup>. Consult boilermaker for recommended TDS and max conductivity if available.

Boiler Type	Max TDS (ppm)	Max µmho
2 Pass Fire-Tube	4,500	6,716
3 Pass Fire-Tube	3,000 to 3,500	4,851
Low Pressure Water-Tube	2,000 to 3,000	3,731
Medium Pressure Water-Tube	1,500	2,239
High Pressure Water-Tube	1,000	1,493

**For example**, for a Chicago High School with a 10,000 kbtu/hr steam boiler in an 15 psi system with no blowdown heat recovery and existing manual blowdown.

$$BDR = \left[ \frac{10,000,000 \times 1855}{((1,166 - 218.3)(1 - 0.2) + (1,166 - 18.8)(0.2))} \right] \times 0.07\% \text{ (manual blowdown)} = 1,314 \text{ klb/year}$$

$$\Delta\text{Therms} = \frac{1,314,803 \text{ lb/year} \times (218.3 - 18.8)}{80.7\% \times 100,000} \times 0.9 = 2,925 \text{ therms}$$

**WATER AND OTHER NON-ENERGY IMPACT DESCRIPTIONS AND CALCULATION**

N/A

**DEEMED O&M COST ADJUSTMENT CALCULATION**

Maintenance personnel should complete annual or semi-annual maintenance inspections of the condensate return system for its optimal performance. The O&M cost shall be included in cost-effectiveness calculations. It is recommended to service the following components to maintain the system’s proper operation: pumps, ensure periodic lubrication for motors, in accordance with the motor manufacturer’s guidelines. Strainers, traps should also be included as an O&M consideration. A custom calculation should be used as necessary.

**MEASURE CODE: CI-HVC-BBHR-V01-240101**

**REVIEW DEADLINE: 1/1/2028**

<sup>1198</sup> “Maximum permissible TDS”, last modified May 12,2023.  
<http://www2.spiraxsarco.com/resources/steam-engineering-tutorials/the-boiler-house/controlling-tds-in-the-boiler-water.asp>

## 4.4.64 Steam Vent Condensers

### DESCRIPTION

According to the Department of Energy<sup>6</sup>, vent condensers can be used with condensate systems to reduce the amount of energy needed to maintain steam temperatures. When flash steam is being vented to atmosphere, it carries with it the energy required to heat water to steam temperature, eventually wasted. Another condenser in the form of a heat exchanger attached to the condensate recovery system will allow this energy to remain within the system and thus reduce the energy needed to heat the condensate back up to the steam pressure necessary for operation. The recovered flash steam will also be distilled after eventually condensing and require less outside water to be introduced to the system. This improves longterm performance by reducing the need for undistilled feed water that has a higher concentration of heavy particulates that scale inside boilers and absorb heat, making the boilers less efficient.

This measure was developed to be applicable to the following program types: RF. If applied to other program types, the measure savings should be verified.

### DEFINITION OF EFFICIENT EQUIPMENT

This measure requires that a heat exchanger be installed with capability to condense flash steam and return distilled water to the condensate tank.

### DEFINITION OF BASELINE EQUIPMENT

This measure requires that a building must be equipped with steam boilers and a condensate recovery tank with flash steam venting in use. This also requires the building to be equipped with multiple pressure loads beyond heating applications and work within the parameters of fully efficient steam systems already. Steam equipment must meet baseline efficiency standards for boilers and condensate recovery, as well as working order steam traps.

### DEEMED LIFETIME OF EFFICIENT EQUIPMENT

The expected measure of life is assumed to be 20 years.<sup>1199</sup>

### DEEMED MEASURE COST

The measure cost of a vent condenser must be custom to the type installed and associated equipment necessary.

### LOADSHAPE

N/A

### COINCIDENCE FACTOR

N/A

---

<sup>1199</sup> The efficiency for Heat Exchangers is stated at 27 years by ASHARE Table 4 Chapter 36, Comparison of Service Life Estimates, 2007 ASHRAE Handbook, HVAC Applications [http://weblegacy.ashrae.org/publicdatabase/system\\_service\\_life.asp?selected\\_system\\_type=3](http://weblegacy.ashrae.org/publicdatabase/system_service_life.asp?selected_system_type=3). However, this is capped at 20 years due to the TRM specified.<sup>7</sup> lifetime of steam boilers.

**Algorithm**

**CALCULATION OF ENERGY SAVINGS**

**ELECTRIC ENERGY SAVINGS**

N/A

**SUMMER COINCIDENT PEAK DEMAND SAVINGS**

N/A

**NATURAL GAS SAVINGS**

Natural gas energy savings are calculated for steam vent condensers per the equations given below.

$$\Delta Therms = \frac{Vent_{rate} \times (H_s - H_w) \times hours}{n_{boiler} \times 100,000} \times SF$$

Where:

$$Vent_{rate} = Condensate_{load} \times \%_{flash\ steam}$$

$Vent_{rate}$  = The rate at which steam passes through the vent (lb/hr)

$Condensate_{load}$  = Estimated condensate load based on pipe size<sup>1200</sup> (lb/hr)

$$Condensate_{load} = 114 [Pipe_{size}]^{2.38}$$

$Pipe_{size}$  = Diameter of vent pipe (inches)

$\%FlashSteam$  = Percentage of flash steam (%)

System Type	Flash Steam percentage <sup>1201</sup> (°F)
5 psi Steam (low pressure)	1.6%
15 psi Steam (low pressure)	3.9%
40 psi Steam (low pressure)	7.8%
65 psi Steam (high pressure)	10.5%
100 psi Steam (high pressure)	13.3%
150 psi Steam (high pressure)	16.3%

If space heating:

Hours = = Equivalent Full Load Hours of heating in Existing Buildings; provided in section 4.4 HVAC End Use.

If process:

Hours = = Annual Hours × UF

<sup>1200</sup> Design of Fluid Systems Hook-ups by Spirax Sarco (1992) Page 37. Table 11 Minimum Dimensions of Flash Vessels. Max condensate quantity and Inlet and Flash Steam Outlet size were plotted against each other. Constants for a power trendline equation were obtained as a result. An oversize factor of 0.5 was applied to the maximum condensate load to account for times when exact pipe sizes cannot be obtained, and the next available pipe size needs to be selected.

<sup>1201</sup> Obtained from the Steam System Modeler Tool (SSM) Flash Tank Calculator by the Department of Energy (DOE). Saturated quality 0 and Tank Pressure 0 psig.

[https://www4.eere.energy.gov/manufacturing/tech\\_deployment/amo\\_steam\\_tool/equipFlashtank](https://www4.eere.energy.gov/manufacturing/tech_deployment/amo_steam_tool/equipFlashtank)

Annual Hours	= Annual operating hours of the facility = Use actual or if unknown 8766
UF	= Utilization Factor = Use actual or if unknown 41.9% <sup>1202</sup>
H <sub>s</sub>	= Enthalphy of steam at venting pressure (Btu/lbm) = 1,150 Btu/lb for steam at atmospheric pressure.
H <sub>w</sub>	= Enthalphy of incoming water from well or municipal system (Btu/lbm) = 18.8 Btu/lbm for incoming water temperature of 50.7°F <sup>1203</sup> .
nboiler	= Efficiency of the steam boiler = Actual or if unknown use default values given below: = 80.7% for steam boilers, except multifamily low-pressure <sup>1204</sup> = 64.8% for multifamily low-pressure steam boilers <sup>1205</sup>
SF	= Savings Factor = Percent of thermal steam energy recovered from vent = 90% of heat recovered. <sup>1206</sup>

**For example**, a vent with a pipe diameter of 2 inches in a steam boiler operating year round at 15 psi

$$\begin{aligned}
 \text{Condensate}_{load} &= 114(2)^{2.38} = 594 \text{ lb/hr} \\
 \text{Vent}_{rate} &= 594 \times 3.9\% = 23.14 \text{ lb/hr} \\
 \Delta\text{Therms} &= \frac{(23.14) \times (1150 - 18.8) \times 8760}{80.7\% \times 100,000} \times 0.9 = 2,557 \text{ therms}
 \end{aligned}$$

#### WATER AND OTHER NON-ENERGY IMPACT DESCRIPTIONS AND CALCULATION

The methodology for calculating water savings involves obtaining the vent rate referenced above. Distilled condensate is ready for productive use to be reintroduced into the system.

#### DEEMED O&M COST ADJUSTMENT CALCULATION

N/A

<sup>1202</sup> From IL TRM Measure 4.4.54 Process Heating Boiler

<sup>1203</sup> Taken from IL TRM Measure 4.4.14 Pipe Insulation

<sup>7</sup> "ASHRAE: HVAC Service Life Database" ASHRAE, last modified May 12, 2023, [http://weblegacy.ashrae.org/publicdatabase/service\\_life.asp](http://weblegacy.ashrae.org/publicdatabase/service_life.asp)

<sup>1204</sup> Ibid

<sup>1205</sup> Katrakis, J. and T.S. Zawacki. "Field-Measured Seasonal Efficiency of Intermediate-sized Low-Pressure Steam Boilers". ASHRAE V99, pt. 2, 1993

<sup>1206</sup> "Recover Heat from Boiler Blowdown" Department of Energy, last modified May 12, 2023. [https://www.energy.gov/sites/prod/files/2014/05/f16/steam10\\_boiler\\_blowdown.pdf](https://www.energy.gov/sites/prod/files/2014/05/f16/steam10_boiler_blowdown.pdf)

**MEASURE CODE: CI-HVC-STVC-V01-240101**

**REVIEW DEADLINE: 1/1/2028**

## 4.5. Lighting End Use

The commercial lighting measures use a standard set of variables for hours of use, waste heat factors, coincident factors and HVAC interaction effects. This table has been developed based on information provided by the various stakeholders. For ease of review, the table is included here and referenced in each measure.

The building characteristics of the eQuest models can be found in the reference table named “EFLH Building Descriptions Updated 2014-11-21.xlsx”. The OpenStudio models are based upon the DOE Prototypes described in NREL’s “U.S. Department of Energy Commercial Reference Building Models of the National Building Stock” and a calibration log file that documents all of the variations made to each model to get them calibrated is provided in “IL-Calibration-Log\_2019-08-27.xlsx”. Documents and all models are all available on the SharePoint site.

Note where a measure installation is within a building or application that does not fit with any of the defined building types below, the user should apply custom assumptions where it is reasonable to estimate them, else the building of best fit should be utilized.

Building/Space Type	Fixture Annual Operating Hours <sup>1207</sup>	Screw based bulb Annual Operating hours <sup>1208</sup>	Waste Heat Cooling Energy WHFe <sup>1209</sup>	Waste Heat Cooling Demand WHFd	Coincidence Factor CF <sup>1210</sup>	Waste Heat Gas Heating IFTherms <sup>1211</sup>	Waste Heat Electric Resistance Heating IFkWh <sup>1212</sup>	Waste Heat Electric Heat Pump Heating IFkWh	Model Source
Agriculture – Chicken Broilers <sup>1213</sup>	3,251	3,251	1.00	1.00	0.76	0.000	0.000	0.000	n/a
Agriculture – Chicken Breeders	4,606	4,606	1.00	1.00	0.95	0.000	0.000	0.000	n/a
Agriculture – Chicken Layers	4,914	4,914	1.00	1.00	0.95	0.000	0.000	0.000	n/a

<sup>1207</sup>Fixtures hours of use are based upon schedule assumptions used in the eQuest models, except for those building types where Illinois based metering results provide a statistically valid estimate (currently: College, Elementary School, High School, Manufacturing, Low and Mid rise Office, Retail Department Store and Warehouse) or Grocery which is based on logging survey at 28 grocery stores in a Massachusetts DNV-GL “Lighting Hours of Use Study” report, April 12,2019. Miscellaneous is a weighted average of indoor spaces using the relative area of each building type in the region (CBECS).

<sup>1208</sup> Hours of use for screw based bulbs are derived from DEER 2008 by building type for cfls. Garage, exterior and multi-family common area values are from the Hours of Use Table in this document. Miscellaneous is an average of interior space values. Some building types are averaged when DEER has two values: these include office, restaurant and retail. Healthcare clinic uses the hospital value.

<sup>1209</sup> The Waste Heat Factor for Energy and is developed using EQuest models for various building types base on Chicago Illinois (closest to statewide average HDD and CDD). Exterior and garage values are 1, unknown is a weighted average of the other building types.

<sup>1210</sup>Coincident diversity factors are based on either combined IL evaluation results (College, Elementary School, High School, Manufacturing, Low and Mid rise Office, Retail Department Store and Warehouse), case lighting projects performed over several years by Michaels Energy in Illinois and other jurisdictions (Refrigerated and Freezer Cases), or based upon schedules defined in the eQuest models described (all others).

<sup>1211</sup> IFkWh Resistance value is developed using EQuest or OpenStudio models consistent with methodology for Waste Heat Factor for Energy.

<sup>1212</sup> Heat penalty assumptions are based on converting the IFkWh Resistance multiplier value in to IFtherms or IF kWhHeat Pump by applying relative heating system efficiencies. The gas efficiency was assumed to be 80% AFUE and the electric resistance is assumed to be 100%, for Heat Pump is assumed to be 2.3COP.

<sup>1213</sup> Agriculture lighting loadshapes, operational hours, and HVAC interactive factors were developed based on field experience and research material for the general agriculture, indoor agriculture, poultry and dairy commodities. Please see the excel files, ‘General Agriculture Loadshape’ and ‘Indoor Agriculture Lighting Loadshape’ on the 8760-calculation approach and for more detail. Due to livestock housing having little to no mechanical cooling systems, waste heat cooling and associated demand factors were assumed to be 1.00.

Building/Space Type	Fixture Annual Operating Hours <sup>1207</sup>	Screw based bulb Annual Operating hours <sup>1208</sup>	Waste Heat Cooling Energy WHFe <sup>1209</sup>	Waste Heat Cooling Demand WHFd	Coincidence Factor CF <sup>1210</sup>	Waste Heat Gas Heating IFTherms <sup>1211</sup>	Waste Heat Electric Resistance Heating IFkWh <sup>1212</sup>	Waste Heat Electric Heat Pump Heating IFkWh	Model Source
Agriculture – Turkey Hens	2,231	2,231	1.00	1.00	0.76	0.000	0.000	0.000	n/a
Agriculture – Turkey Toms	5,351	5,351	1.00	1.00	0.95	0.000	0.000	0.000	na
Agriculture – Turkey Breeder Hens	4,396	4,396	1.00	1.00	0.95	0.000	0.000	0.000	n/a
Agriculture – Turkey Breeder Toms	5,446	5,446	1.00	1.00	0.95	0.000	0.000	0.000	n/a
Agriculture – Dairy Long Day Lighting	6,205	6,205	1.00	1.00	0.95	0.000	0.000	0.000	n/a
Assisted Living	7,862	5,950	1.14	1.30	0.66	0.035	0.823	0.358	eQuest
Auto Dealership	4,099	2,935	1.16	1.24	0.97	0.013	0.315	0.137	OpenStudio
Childcare/Pre-School	2,860	2,860	1.17	1.29	0.72	0.018	0.420	0.183	eQuest
College	3,395	2,588	1.02	1.54	0.63	0.023	0.548	0.238	OpenStudio
Convenience Store	4,672	3,650	1.09	1.26	0.76	0.035	0.828	0.360	eQuest
Drug Store	4,093	2,935	1.05	1.34	1.00	0.017	0.394	0.171	OpenStudio
Elementary School	3,038	2,118	1.04	1.51	0.65	0.019	0.455	0.198	OpenStudio
Emergency Services	2,698	3,088	1.06	1.09	0.65	0.001	0.014	0.006	OpenStudio
Garage	3,401	3,540	1.00	1.00	0.92	0.000	0.000	0.000	eQuest
Garage, 24/7 lighting	8,766	8,766	1.00	1.00	1.00	0.000	0.000	0.000	eQuest
Grocery	5,468	3,650	1.05	1.22	0.82	0.010	0.230	0.100	OpenStudio
Healthcare Clinic	3,890	4,207	1.14	1.04	0.67	0.020	0.463	0.201	OpenStudio
High School	3,038	2,327	1.15	1.40	0.65	0.011	0.249	0.108	OpenStudio
Hospital - CAV no econ	7,616	4,207	1.17	1.32	0.56	0.009	0.211	0.092	OpenStudio
Hospital - CAV econ	7,616	4,207	1.14	1.27	0.56	0.009	0.205	0.089	OpenStudio
Hospital - VAV econ	7,616	4,207	1.13	1.35	0.56	0.006	0.148	0.064	OpenStudio
Hospital - FCU	7,616	4,207	1.16	1.42	0.56	0.000	0.000	0.000	OpenStudio
Manufacturing Facility	4,618	2,629	1.02	1.04	0.81	0.012	0.270	0.117	eQuest
MF - High Rise - Common	6,138	5,950	1.20	1.24	0.90	0.005	0.109	0.047	OpenStudio
MF - Mid Rise - Common	5,216	5,950	1.11	1.16	0.62	0.021	0.484	0.211	OpenStudio
Hotel/Motel - Guest	2,390	777	1.17	1.21	0.46	0.020	0.468	0.204	OpenStudio
Hotel/Motel - Common	6,138	4,542	1.09	1.26	0.85	0.017	0.406	0.176	OpenStudio
Movie Theater	3,506	5,475	1.11	1.38	0.53	0.029	0.673	0.293	eQuest
Office - High Rise - CAV no econ	2,886	3,088	1.22	1.30	0.60	0.006	0.149	0.065	OpenStudio
Office - High Rise - CAV econ	2,886	3,088	1.00	1.07	0.57	0.039	0.905	0.394	eQuest
Office - High Rise - VAV econ	2,886	3,088	1.06	1.65	0.60	0.015	0.345	0.150	OpenStudio

Building/Space Type	Fixture Annual Operating Hours <sup>1207</sup>	Screw based bulb Annual Operating hours <sup>1208</sup>	Waste Heat Cooling Energy WHFe <sup>1209</sup>	Waste Heat Cooling Demand WHFd	Coincidence Factor CF <sup>1210</sup>	Waste Heat Gas Heating IFTherms <sup>1211</sup>	Waste Heat Electric Resistance Heating IFkWh <sup>1212</sup>	Waste Heat Electric Heat Pump Heating IFkWh	Model Source
Office - High Rise - FCU	2,886	3,088	1.21	1.17	0.60	0.007	0.153	0.067	OpenStudio
Office - Low Rise	2,698	3,088	1.10	1.26	0.52	0.010	0.231	0.100	OpenStudio
Office - Mid Rise	3,266	3,088	1.10	1.36	0.60	0.016	0.378	0.164	OpenStudio
Religious Building	2,085	1,664	1.12	1.37	0.48	0.015	0.356	0.155	eQuest
Restaurant	5,571	4,784	1.08	1.10	1.00	0.009	0.208	0.090	OpenStudio
Retail - Department Store	4,099	2,935	1.06	1.06	0.94	0.015	0.346	0.150	OpenStudio
Retail - Strip Mall	4,093	2,935	1.12	1.29	0.71	0.019	0.450	0.196	eQuest
Warehouse	3,135	4,293	1.02	1.17	0.85	0.016	0.378	0.164	OpenStudio
Unknown	3,379	3,612	1.08	1.30	0.67	0.015	0.354	0.154	n/a
Exterior – dusk to dawn <sup>1214</sup>	4,303	4,303	1.00	1.00	0.00	0.000	0.000	0.000	n/a
Exterior – dusk to business close	See calculation below		1.00	1.00	0.00	0.000	0.000	0.000	n/a
Low-Use Small Business	2,954	2,954	1.31	1.53	0.66	0.023	0.524	0.262	n/a
Uncooled Building	Varies	varies	1.00	1.00	0.66	0.014	0.320	0.160	n/a
Refrigerated Cases	5,802	n/a	1.29 <sup>1215</sup>	1.29	1.00	0.000	0.000	0.000	n/a
Freezer Cases	5,802	n/a	1.50 <sup>1216</sup>	1.5	1.00	0.000	0.000	0.000	n/a

**Annual Operating Hours – Spaces with Lighting Controls**

For spaces where occupancy or daylight sensors are known to be already installed, the user should adjust the Annual Operating Hours using the formula below. For v9.0, the TAC agreed that if current state is unknown by the implementer, then subsequent evaluation should assume the space does not have lighting controls. Over 2021 program year, this should be evaluated and the TAC will determine if a different unknown assumption should be used from V10 on.

$$\text{Sensor Controlled Hours} = \text{Annual Operating Hours} * (1 - \text{ESF})$$

Where:

<sup>1214</sup> Based on Navigant verified value using 2014 Astronomical Applications Department, U.S. Naval Observatory data for ComEd’s service territory. See Navigant Memorandum ‘RE: LED Street Lighting Program Hours of Use for the ComEd and DCEO Programs. June 21, 2017’.

<sup>1215</sup> For closed refrigerated case lighting (open cases should use building type WHF), the value is 1.29 (calculated as  $(1 + (1.0 / 3.5))$ ). Based on the assumption that all lighting in refrigerated cases is mechanically cooled, with a typical 3.5 COP refrigeration system efficiency, and assuming 100% of lighting heat needs to be mechanically cooled at time of summer peak. Assumes 3.5 COP for medium temp cases based on the average of standard reciprocating and discus compressor efficiencies with Saturated Suction Temperatures of 20°F and a condensing temperature of 90°F.

<sup>1216</sup> For closed freezer case lighting (open cases should use building type WHF), the value is 1.50 (calculated as  $(1 + (1.0 / 2.0))$ ). Based on the assumption that all lighting in freezer cases is mechanically cooled, with a typical 2.0 COP freezer system efficiency, and assuming 100% of lighting needs to be mechanically cooled at time of summer peak. Assumes 2.0 COP for low temp cases based on the average of standard reciprocating and discus compressor efficiencies with Saturated Suction Temperatures of -20°F and a condensing temperature of 90°F.



Annual Operating Hours = Average hours of use per year for specific space type, provided in the Reference Table above.

ESF = Energy Savings factor (represents the percentage reduction to the operating Hours from the non-controlled baseline lighting system),

Table from Measure 4.5.10 Lighting Controls:

Lighting Control Type	Energy Savings Factor <sup>1217</sup>
Fixture Measurement of Control savings through Networked Trending	Custom
Interior Occupancy Sensor (Switch, Wall, Fixture or Remote Mounted or Integrated in Fixture)	24% 37% with High End Trim
Interior Occupancy Sensor configured as "Vacancy Sensor" (Switch, Wall, Fixture or Remote Mounted or Integrated in Fixture)	31% 44% with High End Trim
Interior Daylight Sensor (Wall, Fixture or Remote Mounted)	28% 41% with High End Trim
Interior Dual Occupancy & Daylight Sensor (Integrated of Fixture Mounted)	38% 51% with High End Trim
Interior Networked Luminaire-Level Lighting Controls	61%
Interior Networked Lighting Controls Only with No LLLCs	35%
Interior Networked Lighting Controls (Unknown or mixed LLLCs)	49%
Refrigerated Case Occupancy Sensor – Freezer and Cooler	27%
Exterior Occupancy Sensor	41%
No Lighting Control	0%

Note, if a program is installing lighting fixtures *and* controls, the interactive effect should be accounted for by assuming fixture watt savings for full annual operating hours, control savings on efficient fixture.

**Exterior Lighting Hours – dusk to business close**

$$\text{Hours} = (6.19 * \text{Days}) + (\% \text{Adj} * \text{Days})$$

Where:

$$6.19 = \text{Average hours per day between dusk and midnight}^{1218}$$

<sup>1217</sup> Interior controls % savings based except where noted on LBNL, Williams et al, "Lighting Controls in Commercial Buildings", 2012, p172. ESF for Vacancy Sensors is based on Papamichael, Konstantions, Bi-Level Switching in Office Spaces, California Lighting Technology Center, February 1,2010. See Figure 8 on page 10 for relevant study results. The study shows a 30% extra savings above a typical occupancy sensor; 24% \* 1.3 = 31%.

ESF for Luminaire Level Lighting Controls, and 10% High End Trim adder are based upon review of:

Pacific Northwest National Laboratory, "Evaluation of Advanced Lighting Control Systems in a Working Office Environment", November 2018.

Schuetter et al., "Cree SmartCast Lighting Retrofit Demonstration: LED Fixtures and Controls for Advanced Holistic Lighting Solutions", September 2020 (expected).

DesignLights Consortium and NEEA, "Energy Savings from Networked Lighting Control and Luminaire-level Lighting Control Systems: 2020 Update", 2020 (expected).

Refrigerated Case occupancy sensors ESF is based on percentage of operating hours spent in low-power operation during vacant periods, found in SDG&E workpaper: WPSDGENRLG0027.

Exterior sensors are based upon data from "Application Assessment of Bi-Level LED Parking Lot Lighting" p6.

<sup>1218</sup> Calculated using the eQuest model by finding the total number of hours of exterior lighting consumption between dusk and midnight and dividing by 365 (2261 / 365 = 6.19 hours per day).

Days = Days of business operation

= Actual

%Adj = Percent adjustment dependent on hour closing<sup>1219</sup>

Business closes at	4pm	5pm	6pm	7pm	8pm	9pm	10pm	11pm	12pm	1am	2am	3am
%Adj	-619%	-604%	-564%	-500%	-400%	-300%	-200%	-100%	0%	100%	200%	300%

For example a business open until 8pm, 260 days per year, would assume:

$$\text{Hours} = (6.19 * 260) + (-400\% * 260) = 569.4 \text{ hours}$$

---

<sup>1219</sup> See "IL TRM Ext Lighting.xlsx" for calculation.

4.5.1 Commercial ENERGY STAR Compact Fluorescent Lamp (CFL) – Retired 12/31/2018,  
Removed in v8

## 4.5.2 Fluorescent Delamping

### DESCRIPTION

This measure addresses the permanent removal of existing 8', 4', 3', and 2' fluorescent lamps. Unused lamps, lamp holders, and ballasts must be permanently removed from the fixture. This measure is applicable when retrofitting from T12 lamps to T8 lamps or simply removing lamps from a T8 fixture. Removing lamps from a T12 fixture that is not being retrofitted with T8 lamps are not eligible for this incentive.

Customers are responsible for determining whether or not to use reflectors in combination with lamp removal in order to maintain adequate lighting levels. Lighting levels are expected to meet the Illuminating Engineering Society of North America (IESNA) recommended light levels. Unused lamps, lamp holders, and ballasts must be permanently removed from the fixture and disposed of in accordance with local regulations. A pre-approval application is required for lamp removal projects.

This measure was developed to be applicable to the following program types: RF. If applied to other program types, the measure savings should be verified.

### DEFINITION OF EFFICIENT EQUIPMENT

Savings are defined on a per removed lamp basis. The retrofit wattage (efficient conditioned) is therefore assumed to be zero. The savings numbers provided below are for the straight lamp removal measures, as well as the lamp removal and install reflector measures. The lamp installed/retrofit is captured in another measure.

### DEFINITION OF BASELINE EQUIPMENT

The baseline condition is either a T12 or a T8 lamp with default wattages provided below. Note, if the program does not allow for the lamp type to be known, then a T12:T8 weighting of 40%:60% can be applied.<sup>1220</sup>

### DEEMED LIFETIME OF EFFICIENT EQUIPMENT

The measure life is assumed to be 11 years per DEER 2005.

### DEEMED MEASURE COST

The incremental capital cost is provided in the table below:

Measure Category	Value	Source
8-Foot Lamp Removal	\$16.00	ComEd/KEMA regression <sup>1221</sup>
4-Foot Lamp Removal	\$12.00	ICF Portfolio Plan
8-Foot Lamp Removal with reflector	\$30.00	KEMA Assumption
4-Foot Lamp Removal with reflector	\$25.00	KEMA Assumption
2-Foot or 3-Foot Removal	\$12.35	KEMA Assumption
2-Foot or 3-Foot Removal with reflector	\$25.70	KEMA Assumption

### LOADSHAPE

Loadshape C06 - Commercial Indoor Lighting

Loadshape C07 - Grocery/Conv. Store Indoor Lighting

Loadshape C08 - Hospital Indoor Lighting

<sup>1220</sup> Based on ComEd's 2019 Baseline Survey results indicating approximately 40% of linear fixtures are T12s.

<sup>1221</sup> Based on the assessment of active projects in the 2008-09 ComEd Smart Ideas Program. See files "ltg costs 12-10-10.xl." and "Lighting Unit Costs 102605.doc".

- Loadshape C09 - Office Indoor Lighting
- Loadshape C10 - Restaurant Indoor Lighting
- Loadshape C11 - Retail Indoor Lighting
- Loadshape C12 - Warehouse Indoor Lighting
- Loadshape C13 - K-12 School Indoor Lighting
- Loadshape C14 - Indust. 1-shift (8/5) (e.g., comp. air, lights)
- Loadshape C15 - Indust. 2-shift (16/5) (e.g., comp. air, lights)
- Loadshape C16 - Indust. 3-shift (24/5) (e.g., comp. air, lights)
- Loadshape C17 - Indust. 4-shift (24/7) (e.g., comp. air, lights)
- Loadshape C18 - Industrial Indoor Lighting
- Loadshape C19 - Industrial Outdoor Lighting
- Loadshape C20 - Commercial Outdoor Lighting

**COINCIDENCE FACTOR**

The summer peak coincidence factor for this measure is dependent on the location type. Values are provided for each building type in the reference section below.

---



---

**Algorithm**

---



---

**CALCULATION OF SAVINGS**

**ELECTRIC ENERGY SAVINGS**

$$\Delta kWh = ((WattsBase - WattsEE) / 1000) * ISR * Hours * WHFe$$

Where:

WattsBase = Assume wattage reduction of lamp removed

	Wattage of lamp removed <sup>1222</sup>		Weighted average 40% T12, 60% T8
	T8	T12	
8-ft T8	38.6	60.3	47.3
4-ft T8	19.4	33.7	25.1
3-ft T8	14.6	40.0	24.8
2-ft T8	9.8	28.0	17.1

WattsEE = 0

ISR = In Service Rate or the percentage of units rebated that get installed.  
 =100% if application form completed with sign off that equipment permanently removed and disposed of.

Hours = Average hours of use per year are provided in Reference Table in Section 4.5.  
 If unknown use the Miscellaneous value.

---

<sup>1222</sup> Default wattage reduction is based on averaging the savings from moving from a 2 to 1, 3 to 2 and 4 to 3 lamp fixture, as provided in the Standard Performance Contract Procedures Manual: Appendix B: Table of Standard Fixture Wattages, Version 3.0, SCE, March 2004. An adjustment is made to the T8 delamped fixture to account for the significant increase in ballast factor. See 'Delamping calculation.xls' for details.

WHFe = Waste heat factor for energy to account for cooling energy savings from efficient lighting are provided below for each building type in Reference Table in Section 4.5. If unknown, use the Miscellaneous value.

**For example**, delamping a 4 ft T8 fixture in an office building:

$$\begin{aligned} \Delta kWh &= ((19.4 - 0)/1000) * 1.0 * 4439 * 1.25 \\ &= 107.6 \text{ kWh} \end{aligned}$$

### HEATING PENALTY

If electrically heated building:

$$\Delta kWh_{\text{heatpenalty}}^{1223} = (((\text{WattsBase} - \text{WattsEE})/1000) * \text{ISR} * \text{Hours} * -\text{IFkWh})$$

Where:

IFkWh = Lighting-HVAC Interaction Factor for electric heating impacts; this factor represents the increased electric space heating requirements due to the reduction of waste heat rejected by the efficient lighting. Values are provided in the Reference Table in Section 4.5. If unknown, use the Miscellaneous value.

**For example**, delamping a 4 ft T8 fixture in a heat pump heated office building:

$$\begin{aligned} \Delta kWh_{\text{heatpenalty}} &= ((19.4 - 0)/1000) * 1.0 * 4439 * -0.151 \\ &= -13.0 \text{ kWh} \end{aligned}$$

### SUMMER COINCIDENT PEAK DEMAND SAVINGS

$$\Delta kW = ((\text{WattsBase} - \text{WattsEE})/1000) * \text{ISR} * \text{WHFd} * \text{CF}$$

Where:

WHFd = Waste heat factor for demand to account for cooling savings from efficient lighting in cooled buildings is provided in the Reference Table in Section 4.5. If unknown, use the Miscellaneous value..

CF = Summer Peak Coincidence Factor for measure is provided in the Reference Table in Section 4.5. If unknown, use the Miscellaneous value..

Other factors as defined above

**For example**, delamping a 4 ft T8 fixture in an office building:

$$\begin{aligned} \Delta kW &= ((19.4 - 0)/1000) * 1.0 * 1.3 * 0.66 \\ &= 0.017 \text{ kW} \end{aligned}$$

### FOSSIL FUEL SAVINGS

Heating Penalty if fossil fuel heated building (or if heating fuel is unknown):

$$\Delta \text{Therms}^{1224} = (((\text{WattsBase} - \text{WattsEE})/1000) * \text{ISR} * \text{Hours} * -\text{IFTherms})$$

Where:

IFTherms = Lighting-HVAC Interaction Factor for gas heating impacts; this factor represents the increased gas space heating requirements due to the reduction of waste heat rejected by

<sup>1223</sup>Negative value because this is an increase in heating consumption due to the efficient lighting.

<sup>1224</sup> Negative value because this is an increase in heating consumption due to the efficient lighting.

the efficient lighting. Values are provided in the Reference Table in Section 4.5. If unknown, use the Miscellaneous value.

Other factors as defined above

**For example**, delamping a 4 ft T8 fixture in an office building:

$$\begin{aligned}\Delta\text{Therms} &= ((19.4 - 0)/1000) * 1.0 * 4439 * -0.016 \\ &= -1.4 \text{ therms}\end{aligned}$$

**WATER IMPACT DESCRIPTIONS AND CALCULATION**

N/A

**DEEMED O&M COST ADJUSTMENT CALCULATION**

N/A

**MEASURE CODE: CI-LTG-DLMP-V03-210101**

**REVIEW DEADLINE: 1/1/2026**

### 4.5.3 High Performance and Reduced Wattage T8 Fixtures and Lamps

#### DESCRIPTION

This measure applies to “High Performance T8” (HPT8) lamp/ballast systems that have higher lumens per watt than standard T8 systems. This measure applies to the installation of new equipment with efficiencies that exceed that of the equipment that would have been installed following standard market practices and is applicable to time of sale as well as retrofit measures. Retrofit measures may include new fixtures or relamp/reballast measures. In addition, options have been provided to allow for the “Reduced Wattage T8 lamps” or RWT8 lamps that result in re-lamping opportunities that produce equal or greater light levels than standard T8 lamps while using fewer watts.

If the implementation strategy does not allow for the installation location to be known, a deemed split of 100% Commercial and 0% Residential should be used.<sup>1225</sup>

This measure was developed to be applicable to the following program types: TOS, EREP, DI.

If applied to other program types, the measure savings should be verified.

The measure applies to all commercial HPT8 installations excluding new construction and major renovation or change of use measures (see lighting power density measure). Lookup tables have been provided to account for the different types of installations. Whenever possible, actual costs and hours of use should be utilized for savings calculations. Default new and baseline assumptions have been provided in the reference tables. Default component costs and lifetimes have been provided for Operating and Maintenance Calculations. Please see the Definition Table to determine applicability for each program. HPT8 configurations not included in the TRM may be included in custom program design using the provided algorithms as long as energy savings is achieved. The following table defines the applicability for different programs:

Time of Sale (TOS)	Early Replacement (EREP) and Direct Install (DI)
<p>This measure relates to the installation of new equipment with efficiency that exceeds that of equipment that would have been installed following standard market practices. In general, the measure will include qualifying high efficiency low ballast factor ballasts paired with high efficiency long life lamps as detailed in the attached tables. High-bay applications use this system paired with qualifying high ballast factor ballasts and high performance 32 w lamps. Custom lighting designs can use qualifying low, normal or high ballast factor ballasts and qualifying lamps in lumen equivalent applications where total system wattage is reduced when calculated using the Calculation of Savings Algorithms.</p>	<p>This measure relates to the replacement of existing equipment with new equipment with efficiency that exceeds that of the existing equipment. In general, the retrofit will include qualifying high efficiency low ballast factor ballasts paired with high efficiency long life lamps as detailed in the attached tables. Custom lighting designs can use qualifying low, normal or high ballast factor ballasts and qualifying lamps in lumen equivalent applications where total system wattage is reduced when calculated using the Calculation of Savings Algorithms.</p> <p>High efficiency troffers (new/or retrofit) utilizing HPT8 technology can provide even greater savings. When used in a high-bay application, high-performance T8 fixtures can provide equal light to HID high-bay fixtures, while using fewer watts; these systems typically utilize high ballast factor ballasts, but qualifying low and normal ballast factor ballasts may be used when appropriate light levels are provided and overall wattage is reduced.</p>

<sup>1225</sup> Based on weighted average of Final ComEd’s Instant Discounts program data from PY7 and PY9. For Residential installations, hours of use assumptions from ‘5.5 Interior Hardwired Compact Fluorescent Lamp (CFL) Fixture’ measure should be used.



**DEFINITION OF EFFICIENT EQUIPMENT**

The efficient conditions for all applications are a qualifying HP or RWT8 fixture and lamp/ballast combinations listed on the CEE website under qualifying HP T8 products<sup>1226</sup> and qualifying RWT8 products.<sup>1227</sup>

The definition of efficient equipment varies based on the program and is defined below:

Time of Sale (TOS)	Early Replacement (EREP) and Direct Install (DI)
<p>High efficiency troffers combined with high efficiency lamps and ballasts allow for fewer lamps to be used to provide a given lumen output. High efficiency troffers must have a fixture efficiency of 80% or greater to qualify. Default values are given for a 2 lamp HPT8 fixture replacing a 3 lamp standard efficiency T8 fixture, but other configurations may qualify and the Calculation of savings algorithm used to account for base watts being replaced with EE watts.</p> <p>High bay fixtures must have fixture efficiencies of 85% or greater.</p> <p>RWT8 lamps: 2', 3' and 8' lamps must meet the wattage requirements specified in the RWT8 new and baseline assumptions table. This measure assumes a lamp only purchase.</p>	<p>High efficiency troffers (new or retrofit kits) combined with high efficiency lamps and ballasts allow for fewer lamps to be used to provide a given lumen output. High efficiency troffers must have a fixture efficiency of 80% or greater to qualify. Default values are given for a 2 lamp HPT8 fixture replacing a 3 lamp standard efficiency T8 fixture, but other configurations may qualify and the Calculation of savings algorithm used to account for base watts being replaced with EE watts.</p> <p>High bay fixtures will have fixture efficiencies of 85% or greater.</p> <p>RWT8: 2', 3' and 8' lamps must meet the wattage requirements specified in the RWT8 new and baseline assumptions table.</p>

**DEFINITION OF BASELINE EQUIPMENT**

The definition of baseline equipment varies based on the program and is defined below:

Time of Sale (TOS)	Early Replacement (EREP) and Direct Install (DI)
<p>The baseline is standard efficiency T8 systems that would have been installed. The baseline for high-bay fixtures is pulse start metal halide fixtures, the baseline for a 2 lamp high efficiency troffer is a 3 lamp standard efficiency troffer.</p>	<p>The baseline is the existing system.</p> <p>In July 14, 2012, Federal Standards were enacted that were expected to eliminate T-12s as an option for linear fluorescent fixtures. Through v3.0 of the TRM, it was assumed that the T-12 would no longer be baseline for retrofits from 1/1/2016. However, due to significant loopholes in the legislation, T-12 compliant product is still freely available and in Illinois T-12s continue to hold a significant share of the existing and replacement lamp market. Therefore the timing of the sunseting of T-12s as a viable baseline has been pushed back and will be revisited in future update sessions.</p> <p>There will be a baseline shift applied to all early replacement measures with a T12 baseline. See table C-1.</p>

**DEEMED LIFETIME OF EFFICIENT EQUIPMENT**

The deemed lifetime of efficient equipment varies based on the program and is defined below:

<sup>1226</sup> Consortium for Energy Efficiency (CEE) Energy Efficiency Program Library, High-Performance T8 Specification, June 30, 2009.

<sup>1227</sup> Consortium for Energy Efficiency (CEE) Energy Efficiency Program Library, Reduced Wattage T8 Specification, July 29, 2013.

Time of Sale (TOS)	Early Replacement (EREP) and Direct Install (DI)
<p>Fixture lifetime is rated lifetime of fixture/hours of use. If unknown default is 12 years.<sup>1228</sup></p> <p>Fixture retrofits which utilize RWT8 lamps have a lifetime equivalent to the life of the lamp, capped at 15 years. There is no guarantee that a reduced wattage lamp will be installed at time of burnout, but if one is, savings will be captured in the RWT8 measure below.</p> <p>RWT8 lifetime is the life of the product, at the reported operating hours (lamp life in hours divided by operating hours per year – see reference table "RWT8 Component Costs and Lifetime"), capped at 12 years.<sup>1229</sup></p>	<p>Fixture lifetime is rated lifetime of fixture/hours of use. If unknown default is 15 years.</p> <p>As per explanation above, for existing T12 fixtures, a mid life baseline shift should be applied as described in table C-1. Note, since the fixture lifetime is deemed at 12 years, the replacement cost of both the lamp and ballast should be incorporated in to the O&amp;M calculation.</p>

**DEEMED MEASURE COST**

The deemed measure cost is found in the reference table at the end of this characterization.

**LOADSHAPE**

- Loadshape C06 - Commercial Indoor Lighting
- Loadshape C07 - Grocery/Conv. Store Indoor Lighting
- Loadshape C08 - Hospital Indoor Lighting
- Loadshape C09 - Office Indoor Lighting
- Loadshape C10 - Restaurant Indoor Lighting
- Loadshape C11 - Retail Indoor Lighting
- Loadshape C12 - Warehouse Indoor Lighting
- Loadshape C13 - K-12 School Indoor Lighting
- Loadshape C14 - Indust. 1-shift (8/5) (e.g., comp. air, lights)
- Loadshape C15 - Indust. 2-shift (16/5) (e.g., comp. air, lights)
- Loadshape C16 - Indust. 3-shift (24/5) (e.g., comp. air, lights)
- Loadshape C17 - Indust. 4-shift (24/7) (e.g., comp. air, lights)
- Loadshape C18 - Industrial Indoor Lighting
- Loadshape C19 - Industrial Outdoor Lighting
- Loadshape C20 - Commercial Outdoor Lighting

<sup>1228</sup> 12 years is based on average of mostly CEE lamp products (9 years), T5 lamps (10.7 years) and GDS Measure Life Report, June 2007, (15 years), as recommended in Navigant ‘ComEd Effective Useful Life Research Report’, May 2018.

<sup>1229</sup> ibid

**Algorithm**

**CALCULATION OF SAVINGS**

**ELECTRIC ENERGY SAVINGS**

$$\Delta kWh = ((Watts_{base} - Watts_{EE}) / 1000) * Hours * WHF_e * ISR$$

Where:

**Watts<sub>base</sub>** = Input wattage of the existing system which depends on the baseline fixture configuration (number and type of lamp) and number of fixtures. Value can be selected from the appropriate reference table as shown below, or a custom value can be entered if the configurations in the tables is not representative of the existing system.

Program	Reference Table
Time of Sale	A-1: HPT8 New and Baseline Assumptions
Early Replacement	A-2: HPT8 New and Baseline Assumptions
Reduced Wattage T8, time of sale or Early Replacement	A-3: RWT8 New and Baseline Assumptions

**Watts<sub>EE</sub>** = New Input wattage of EE fixture which depends on new fixture configuration (number of lamps) and ballast factor and number of fixtures. Value can be selected from the appropriate reference table as shown below, of a custom value can be entered if the configurations in the tables is not representative of the existing system.

Program	Reference Table
Time of Sale	A-1: HPT8 New and Baseline Assumptions
Early Replacement	A-2: HPT8 New and Baseline Assumptions
Reduced Wattage T8, time of sale or Early Replacement	A-3: RWT8 New and Baseline Assumptions

**Hours** = Average hours of use per year as provided by the customer or selected from the Reference Table in Section 4.5, Fixture annual operating hours. If hours or building type are unknown, use the Miscellaneous value.

**WHF<sub>e</sub>** = Waste heat factor for energy to account for cooling energy savings from efficient lighting is selected from the Reference Table in Section 4.5 for each building type. If building is un-cooled, the value is 1.0.

**ISR** = In Service Rate or the percentage of units rebated that get installed.  
 =100% if application form completed with sign off that equipment is not placed into storage<sup>1230</sup>

If sign off form not completed assume the following 3 year ISR assumptions:

<sup>1230</sup> Illinois evaluation of PY1 through PY3 has not found that fixtures or lamps placed into storage to be a significant enough issue to warrant including an "In-Service Rate" when commercial customers complete an application form.

Weighted Average 1st year In Service Rate (ISR)	2nd year Installations	3rd year Installations	Final Lifetime In Service Rate
93.4% <sup>1231</sup>	2.5%	2.1%	98.0% <sup>1232</sup>

### HEATING PENALTY

If electrically heated building:

$$\Delta kWh_{\text{heatpenalty}}^{1233} = (((\text{WattsBase} - \text{WattsEE}) / 1000) * \text{ISR} * \text{Hours} * -\text{IFkWh})$$

Where:

IFkWh = Lighting-HVAC Interaction Factor for electric heating impacts; this factor represents the increased electric space heating requirements due to the reduction of waste heat rejected by the efficient lighting. Values are provided in the Reference Table in Section 4.5. If unknown, use the Miscellaneous value.

### SUMMER COINCIDENT DEMAND SAVINGS

$$\Delta kW = ((\text{Watts}_{\text{base}} - \text{Watts}_{\text{EE}}) / 1000) * \text{WHF}_d * \text{CF} * \text{ISR}$$

Where:

WHF<sub>d</sub> = Waste Heat Factor for Demand to account for cooling savings from efficient lighting in cooled buildings is selected from the Reference Table in Section 4.5 for each building type. If the building is not cooled WHF<sub>d</sub> is 1.

CF = Summer Peak Coincidence Factor for measure is selected from the Reference Table in Section 4.5 for each building type. If the building type is unknown, use the Miscellaneous value of 0.66.

Other factors as defined above

### FOSSIL FUEL SAVINGS

$$\Delta \text{Therms}^{1234} = (((\text{WattsBase} - \text{WattsEE}) / 1000) * \text{ISR} * \text{Hours} * -\text{IFTherms})$$

Where:

IFTherms = Lighting-HVAC Integration Factor for gas heating impacts; this factor represents the increased gas space heating requirements due to the reduction of waste heat rejected by the efficient lighting. Please select from the Reference Table in Section 4.5 for each building type.

<sup>1231</sup> Based on ComEd’s Instant Incentives program data from PY7 and PY9, see “IL Commercial Lighting ISR\_2018.xlsx”.

<sup>1232</sup> The 98% Lifetime ISR assumption is based upon review of two evaluations:

‘Nexus Market Research, RLW Analytics and GDS Associates study; ‘New England Residential Lighting Markdown Impact Evaluation, January 20, 2009’ and ‘KEMA Inc, Feb 2010, Final Evaluation Report:, Upstream Lighting Program, Volume 1.’ This implies that only 2% of bulbs purchased are never installed. The second and third year installations are based upon Ameren analysis of the Californian KEMA study showing that 54% of future installs occur in year 2 and 46% in year 3. The 2<sup>nd</sup> and 3<sup>rd</sup> year installations should be counted as part of those future program year savings. Note that this Final Install Rate does NOT account for leakage of purchased bulbs being installed outside of the utility territory. EM&V should assess how and if data from evaluation should adjust this final installation rate to account for this impact

<sup>1233</sup> Negative value because this is an increase in heating consumption due to the efficient lighting.

<sup>1234</sup> Negative value because this is an increase in heating consumption due to the efficient lighting.

**WATER IMPACT DESCRIPTIONS AND CALCULATION**

N/A

**DEEMED O&M COST ADJUSTMENT CALCULATION**

Actual operation and maintenance costs will vary by specific equipment installed/replaced. See Reference tables for Operating and Maintenance Values;

Program	Reference Table
Time of Sale	B-1: HPT8 Component Costs and Lifetime
Early Replacement	B-2: HPT8 Component Costs and Lifetime
Reduced Wattage T8, time of sale or Early Replacement	B-3: HPT8 Component Costs and Lifetime

**REFERENCE TABLES**

See following page

A-1: Time of Sale: HPT8 New and Baseline Assumptions<sup>1235</sup>

EE Measure Description	Nominal Watts	Watts <sub>EE</sub>	Baseline Description	Nominal Watt	Watts <sub>BASE</sub>	Incremental Cost	Watts <sub>SAVE</sub>
4-Lamp HPT8 w/ High-BF Ballast High-Bay	128	147.2	200 Watt Pulse Start Metal-Halide	200	232	\$75	84.80
4-Lamp HPT8 w/ High-BF Ballast High-Bay	128	147.2	250 Watt Metal Halide	250	295	\$75	147.80
6-Lamp HPT8 w/ High-BF Ballast High-Bay	192	220.8	320 Watt Pulse Start Metal-Halide	320	348.8	\$75	128.00
6-Lamp HPT8 w/ High-BF Ballast High-Bay	192	220.8	400 Watt Pulse Start Metal Halide	400	455	\$75	234.20
8-Lamp HPT8 w/ High-BF Ballast High-Bay	256	294.4	Proportionally Adjusted according to 6-Lamp HPT8 Equivalent to 320 PSMH	320	476	\$75	181.60
8-Lamp HPT8 w/ High-BF Ballast High-Bay	256	292.4	Proportionally Adjusted according to 6-Lamp HPT8 Equivalent to 400 W Metal Halide	400	618	75	323.60
1-Lamp HPT8-high performance 32 w lamp	32	24.64	1-Lamp Standard F32T8 w/ Elec. Ballast	32	28.16	\$15	3.52
1-Lamp HPT8-high performance 28 w lamp	28	21.56	1-Lamp Standard F32T8 w/ Elec. Ballast	32	28.16	\$15	6.60
1-Lamp HPT8-high performance 25 w lamp	25	19.25	1-Lamp Standard F32T8 w/ Elec. Ballast	32	28.16	\$15	8.91
2-Lamp HPT8 -high performance 32 w lamp	64	49.28	2-Lamp Standard F32T8 w/ Elec. Ballast	64	56.32	\$18	7.04
2-Lamp HPT8-high performance 28 w lamp	56	43.12	2-Lamp Standard F32T8 w/ Elec. Ballast	64	56.32	\$18	13.20
2-Lamp HPT8-high performance 25 w lamp	50	38.5	2-Lamp Standard F32T8 w/ Elec. Ballast	64	56.32	\$18	17.82
3-Lamp HPT8-high performance 32 w lamp	96	73.92	3-Lamp Standard F32T8 w/ Elec. Ballast	96	84.48	\$20	10.56
3-Lamp HPT8-high performance 28 w lamp	84	64.68	3-Lamp Standard F32T8 w/ Elec. Ballast	96	84.48	\$20	19.80
3-Lamp HPT8-high performance 25 w lamp	75	57.75	3-Lamp Standard F32T8 w/ Elec. Ballast	96	84.48	\$20	26.73
4-Lamp HPT8 -high performance 32 w lamp	128	98.56	4-Lamp Standard F32T8 w/ Elec. Ballast	128	112.64	\$23	14.08
4-Lamp HPT8-high performance 28 w lamp	112	86.24	4-Lamp Standard F32T8 w/ Elec. Ballast	128	112.64	\$23	26.40
4-Lamp HPT8-high performance 25 w lamp	100	77	4-Lamp Standard F32T8 w/ Elec. Ballast	128	112.64	\$23	35.64
2-lamp High-Performance HPT8 Troffer	64	49.28	3-Lamp F32T8 w/ Elec. Ballast	96	84.48	\$100	35.20

Table developed using a constant ballast factor of .77 for troffers/linear HPT8 and 1.15 for HPT8 highbay, 1.0 for all MH/MHPS, and 0.95 for T12 and 0.88 for standard T8. Input wattages are an average of manufacturer inputs that account for ballast efficacy

<sup>1235</sup> Watt, lumen, lamp life, and ballast factor assumptions for efficient measures are based upon Consortium for Energy Efficiency (CEE) Commercial Lighting Qualifying Product Lists. Watt, lumen, lamp life, and ballast factor assumptions for baseline fixtures are based upon manufacturer specification sheets. Baseline and efficient measure cost data comes from lighting suppliers, past Efficiency Vermont projects, and professional judgment.

A-2: Early Replacement HPT8 New and Baseline Assumptions<sup>1236</sup>

EE Measure Description	Nominal Watts	Ballast Factor	Watt <sub>EE</sub>	Baseline Description	Nominal Watts	Watt <sub>BASE</sub>	Watt <sub>SAVE</sub>	Full Measure Cost
4-Lamp HPT8 w/ High-BF Ballast High-Bay	128	1.15	147.2	200 Watt Pulse Start Metal-Halide	200	232	84.80	\$200
4-Lamp HPT8 w/ High-BF Ballast High-Bay	128	1.15	147.2	250 Watt Metal Halide	250	295	147.80	\$200
6-Lamp HPT8 w/ High-BF Ballast High-Bay	192	1.15	220.8	320 Watt Pulse Start Metal-Halide	320	348.8	128.00	\$225
6-Lamp HPT8 w/ High-BF Ballast High-Bay	192	1.15	220.8	400 Watt Pulse Start Metal Halide	400	455	234.20	\$225
8-Lamp HPT8 w/ High-BF Ballast High-Bay	256	1.15	294.4	Proportionally Adjusted according to 6-Lamp HPT8 Equivalent to 320 PSMH	320	476	181.60	\$250
8-Lamp HPT8 w/ High-BF Ballast High-Bay	256	1.15	294.4	Proportionally Adjusted according to 6-Lamp HPT8 Equivalent to 400 W Metal Halide	400	618	323.60	\$250
1-Lamp Relamp/Reballast T12 to HPT8	32	0.77	24.64	1-Lamp F34T12 w/ EEMag Ballast	34	42	17.36	\$50
2-Lamp Relamp/Reballast T12 to HPT8	64	0.77	49.28	2-Lamp F34T12 w/ EEMag Ballast	68	67	17.72	\$55
3-Lamp Relamp/Reballast T12 to HPT8	96	0.77	73.92	3-Lamp F34T12 w/ EEMag Ballast	102	104	30.08	\$60
4-Lamp Relamp/Reballast T12 to HPT8	128	0.77	98.56	4-Lamp F34T12 w/ EEMag Ballast	136	144	45.44	\$65
1-Lamp Relamp/Reballast T12 to HPT8	32	0.77	24.64	1-Lamp F40T12 w/ EEMag Ballast	40	41	16.36	\$50
2-Lamp Relamp/Reballast T12 to HPT8	64	0.77	49.28	2-Lamp F40T12 w/ EEMag Ballast	80	87	37.72	\$55
3-Lamp Relamp/Reballast T12 to HPT8	96	0.77	73.92	3-Lamp F40T12 w/ EEMag Ballast	120	141	67.08	\$60
4-Lamp Relamp/Reballast T12 to HPT8	128	0.77	98.56	4-Lamp F40T12 w/ EEMag Ballast	160	172	73.44	\$65
1-Lamp Relamp/Reballast T12 to HPT8	32	0.77	24.64	1-Lamp F40T12 w/ Mag Ballast	40	51	26.36	\$50
2-Lamp Relamp/Reballast T12 to HPT8	64	0.77	49.28	2-Lamp F40T12 w/ Mag Ballast	80	97	47.72	\$55
3-Lamp Relamp/Reballast T12 to HPT8	96	0.77	73.92	3-Lamp F40T12 w/ Mag Ballast	120	135	61.08	\$60
4-Lamp Relamp/Reballast T12 to HPT8	128	0.77	98.56	4-Lamp F40T12 w/ Mag Ballast	160	175	76.44	\$65
1-Lamp Relamp/Reballast T8 to HPT8	32	0.77	24.64	1-Lamp F32T8 w/ Elec. Ballast	32	28.16	3.52	\$50
2-Lamp Relamp/Reballast T8 to HPT8	64	0.77	49.28	2-Lamp F32T8 w/ Elec. Ballast	64	56.32	7.04	\$55
3-Lamp Relamp/Reballast T8 to HPT8	96	0.77	73.92	3-Lamp F32T8 w/ Elec. Ballast	96	84.48	10.56	\$60
4-Lamp Relamp/Reballast T8 to HPT8	128	0.77	98.56	4-Lamp F32T8 w/ Elec. Ballast	128	112.64	14.08	\$65

<sup>1236</sup> Watt, lumen, lamp life, and ballast factor assumptions for efficient measures are based upon Consortium for Energy Efficiency (CEE) Commercial Lighting Qualifying Product Lists. Watt, lumen, lamp life, and ballast factor assumptions for baseline fixtures are based upon manufacturer specification sheets. Baseline and efficient measure cost data comes from lighting suppliers, past Efficiency Vermont projects, Xcel Energy Lighting Efficiency Input Wattage Guide and professional judgment.

EE Measure Description	Nominal Watts	Ballast Factor	Watt <sub>EE</sub>	Baseline Description	Nominal Watts	Watt <sub>BASE</sub>	Watt <sub>SAVE</sub>	Full Measure Cost
2-lamp High-Performance HPT8 Troffer or high efficiency retrofit troffer	64	0.77	49.28	3-Lamp F32T8 w/ Elec. Ballast	96	84.48	35.20	\$100

Table developed using a constant ballast factor of 0.77 for troffers/linear HPT8 and 1.15 for HPT8 highbay, 1.0 for all MH/MHPS, and 0.95 for T12 and 0.88 for standard T8. Input wattages are an average of manufacturer inputs that account for ballast efficacy.

EE Measure Description	Nominal Watts	Watt <sub>EE</sub>	EE Lamp Cost	Baseline Description	Base Lamp Cost	Nominal Watts	Watt <sub>BASE</sub>	Watt <sub>SAVE</sub>	Measure Cost
RW T8 - F28T8 Lamp	28	24.64	\$4.50	F32 T8 Standard Lamp	\$2.50	32	28.16	3.52	\$2.00
RWT8 F2T8 Extra Life Lamp	28	24.64	\$4.50	F32 T8 Standard Lamp	\$2.50	32	28.16	3.52	\$2.00
RWT8 - F32/25W T8 Lamp	25	22.00	\$4.50	F32 T8 Standard Lamp	\$2.50	32	28.16	6.16	\$2.00
RWT8 - F32/25W T8 Lamp Extra Life	25	22.00	\$4.50	F32 T8 Standard Lamp	\$2.50	32	28.16	6.16	\$2.00
RWT8 F17T8 Lamp - 2 ft	16	14.08	\$4.80	F17 T8 Standard Lamp - 2ft	\$2.80	17	14.96	0.88	\$2.00
RWT8 F25T8 Lamp - 3 ft	23	20.24	\$5.10	F25 T8 Standard Lamp - 3ft	\$3.10	25	22.00	1.76	\$2.00
RWT8 F30T8 Lamp - 6' Utube	30	26.40	\$11.31	F32 T8 Standard Utube	\$9.31	32	28.16	1.76	\$2.00
RWT8 F29T8 Lamp - Utube	29	25.52	\$11.31	F32 T8 Standard Utube	\$9.31	32	28.16	2.64	\$2.00
RWT8 F96T8 Lamp - 8 ft	65	57.20	\$9.00	F96 T8 Standard Lamp - 8 ft	\$7.00	70	61.60	4.40	\$2.00

A- 3: RWT8 New and Baseline Assumptions

Table developed using a constant ballast factor of 0.88 for RWT8 and Standard T8.

B-1: Time of Sale T8 Component Costs and Lifetime<sup>1237</sup>

<sup>1237</sup> Watt, lumen, lamp life, and ballast factor assumptions for efficient measures are based upon Consortium for Energy Efficiency (CEE) Commercial Lighting Qualifying Product Lists. Watt, lumen, lamp life, and ballast factor assumptions for baseline fixtures are based upon manufacturer specification sheets. Baseline and efficient measure cost data comes from lighting suppliers, past Efficiency Vermont projects, and professional judgment.



EE Measure Description	EE Lamp Cost	EE Lamp Life (hrs)	EE Lamp Rep. Labor Cost per lamp	EE Ballast Cost	EE Ballast Life (hrs)	EE Ballast Rep. Labor Cost	Baseline Description	Base Lamp Cost	Base Lamp Life (hrs)	Base Lamp Rep. Labor Cost	Base Ballast Cost	Base Ballast Life (hrs)	Base Ballast Rep. Labor Cost
4-Lamp HPT8 w/ High-BF Ballast High-Bay	\$5.00	24000	\$6.67	\$32.50	70000	\$15.00	200 Watt Pulse Start Metal-Halide	\$21.00	10000	\$6.67	\$87.75	40000	\$22.50
6-Lamp HPT8 w/ High-BF Ballast High-Bay	\$5.00	24000	\$6.67	\$32.50	70000	\$15.00	320 Watt Pulse Start Metal-Halide	\$21.00	20000	\$6.67	\$109.35	40000	\$22.50
8-Lamp HPT8 w/ High-BF Ballast High-Bay	\$5.00	24000	\$6.67	\$32.50	70000	\$15.00	Lamp HPT8 Equivalent to 320 PSMH	\$21.00	20000	\$6.67	\$109.35	40000	\$22.50
1-Lamp HPT8 – all qualifying lamps	\$5.00	24000	\$2.67	\$32.50	70000	\$15.00	1-Lamp Standard F32T12 w/ Elec Ballast	\$2.50	20000	\$2.67	\$15.00	70000	\$15.00
2-Lamp HPT8 – all qualifying lamps	\$5.00	24000	\$2.67	\$32.50	70000	\$15.00	2-Lamp Standard F32T12 w/ Elec Ballast	\$2.50	20000	\$2.67	\$15.00	70000	\$15.00
3-Lamp HPT8 – all qualifying lamps	\$5.00	24000	\$2.67	\$32.50	70000	\$15.00	3-Lamp Standard F32T8 w/ Elec. Ballast	\$2.50	20000	\$2.67	\$15.00	70000	\$15.00
4-Lamp HPT8 – all qualifying lamps	\$5.00	24000	\$2.67	\$32.50	70000	\$15.00	4-Lamp Standard F32T8 w/ Elec. Ballast	\$2.50	20000	\$2.67	\$15.00	70000	\$15.00
				\$32.50									
2-lamp High-Performance HPT8 Troffer	\$5.00	24000	\$2.67	\$32.50	70000	\$15.00	3-Lamp F32T8 w/ Elec. Ballast	\$2.50	20000	\$2.67	\$15.00	70000	\$15.00

B-2: T8 Early Replacement Component Costs and Lifetime<sup>1238</sup>

<sup>1238</sup> Cost assumptions for baseline fixtures are based upon manufacturer specification sheets. Baseline and efficient measure cost data comes from lighting suppliers, past Efficiency Vermont projects, and professional judgment.

EE Measure Description	EE Lamp Cost	EE Lamp Life (hrs)	EE Lamp Rep. Labor Cost per lamp	EE Ballast Cost	EE Ballast Life (hrs)	EE Ballast Rep. Labor Cost	Baseline Description	Base Lamp Cost	Base Lamp Life (hrs)	Base Lamp Rep. Labor Cost	Base Ballast Cost	Base Ballast Life (hrs)	Base Ballast Rep. Labor Cost
4-Lamp HPT8 w/ High-BF Ballast High-Bay	\$5.00	24000	\$6.67	\$32.50	70000	\$15.00	200 Watt Pulse Start Metal-Halide	\$29.00	12000	\$6.67	\$87.75	40000	\$22.50
6-Lamp HPT8 w/ High-BF Ballast High-Bay	\$5.00	24000	\$6.67	\$32.50	70000	\$15.00	320 Watt Pulse Start Metal-Halide	\$72.00	20000	\$6.67	\$109.35	40000	\$22.50
8-Lamp HPT8 w/ High-BF Ballast High-Bay	\$5.00	24000	\$6.67	\$32.50	70000	\$15.00	Proportionally Adjusted according to 6-Lamp HPT8 Equivalent to 320 PSMH	\$17.00	20000	\$6.67	\$109.35	40000	\$22.50
1-Lamp Relamp/Reballast T12 to HPT8	\$5.00	24000	\$2.67	\$32.50	70000	\$15.00	1-Lamp F34T12 w/ EEMag Ballast	\$2.70	20000	\$2.67	\$20.00	40000	\$15.00
2-Lamp Relamp/Reballast T12 to HPT8	\$5.00	24000	\$2.67	\$32.50	70000	\$15.00	2-Lamp F34T12 w/ EEMag Ballast	\$2.70	20000	\$2.67	\$20.00	40000	\$15.00
3-Lamp Relamp/Reballast T12 to HPT8	\$5.00	24000	\$2.67	\$32.50	70000	\$15.00	3-Lamp F34T12 w/ EEMag Ballast	\$2.70	20000	\$2.67	\$20.00	40000	\$15.00
4-Lamp Relamp/Reballast T12 to HPT8	\$5.00	24000	\$2.67	\$32.50	70000	\$15.00	4-Lamp F34T12 w/ EEMag Ballast	\$2.70	20000	\$2.67	\$20.00	40000	\$15.00
1-Lamp Relamp/Reballast T8 to HPT8	\$5.00	24000	\$2.67	\$32.50	70000	\$15.00	1-Lamp F32T8 w/ Elec. Ballast	\$2.70	20000	\$2.67	\$20.00	70000	\$15.00
2-Lamp Relamp/Reballast T8 to HPT8	\$5.00	24000	\$2.67	\$32.50	70000	\$15.00	2-Lamp F32T8 w/ Elec. Ballast	\$2.70	20000	\$2.67	\$20.00	70000	\$15.00
3-Lamp Relamp/Reballast T8 to HPT8	\$5.00	24000	\$2.67	\$32.50	70000	\$15.00	3-Lamp F32T8 w/ Elec. Ballast	\$2.70	20000	\$2.67	\$20.00	70000	\$15.00
4-Lamp Relamp/Reballast T8 to HPT8	\$5.00	24000	\$2.67	\$32.50	70000	\$15.00	4-Lamp F32T8 w/ Elec. Ballast	\$2.70	20000	\$2.67	\$20.00	70000	\$15.00
2-lamp High-Performance HPT8 Troffer	\$5.00	24000	\$2.67	\$32.50	70000	\$15.00	3-Lamp F32T8 w/ Elec. Ballast	\$2.50	20000	\$2.67	\$15.00	70000	\$15.00

B-3: Reduced Wattage T8 Component Costs and Lifetime<sup>1239</sup>

EE measure description	EE Lamp Cost	EE Lamp Life (hrs)	Baseline Description	Base Lamp Cost	Base Lamp Life (hrs)	Base Lamp Rep. Labor Cost
RW T8 - F28T8 Lamp	\$4.50	30000	F32 T8 Standard Lamp	\$2.50	15000	\$2.67
RWT8 F2T8 Extra Life Lamp	\$4.50	36000	F32 T8 Standard Lamp	\$2.50	15000	\$2.67
RWT8 - F32/25W T8 Lamp	\$4.50	30000	F32 T8 Standard Lamp	\$2.50	15000	\$2.67
RWT8 - F32/25W T8 Lamp Extra Life	\$4.50	36000	F32 T8 Standard Lamp	\$2.50	15000	\$2.67
RWT8 F17T8 Lamp - 2 ft	\$4.80	18000	F17 T8 Standard Lamp - 2ft	\$2.80	15000	\$2.67
RWT8 F25T8 Lamp - 3 ft	\$5.10	18000	F25 T8 Standard Lamp - 3ft	\$3.10	15000	\$2.67
RWT8 F30T8 Lamp - 6' Utube	\$11.31	24000	F32 T8 Standard Utube	\$9.31	15000	\$2.67
RWT8 F29T8 Lamp - Utube	\$11.31	24000	F32 T8 Standard Utube	\$9.31	15000	\$2.67
RWT8 F96T8 Lamp - 8 ft	\$9.00	24000	F96 T8 Standard Lamp - 8 ft	\$7.00	15000	\$2.67

<sup>1239</sup> Cost assumptions for baseline fixtures are based upon manufacturer specification sheets. Baseline and efficient measure cost data comes from lighting suppliers, past Efficiency Vermont projects, and professional judgment.

C-1: T12 Baseline Adjustment:

For early replacement measures replacing existing T12 fixtures the full savings (as calculated above in the Algorithm section) will be claimed for the remaining useful life of the T12 fixture. This should be calculated as follows:

$$\text{RUL of existing T12 fixture} = (1/3 * 40,000)/\text{Hours}$$

A savings adjustment should then be applied to the annual savings for the remainder of the measure life. The adjustment to be applied for each measure should be calculated as:

$$\% \text{ Adjustment} = (\text{TOS Base Watts} - \text{Efficient Watts}) / (\text{Existing T12 Watts} - \text{Efficient Watts})$$

For example, an existing 2 lamp T12 fixture (87W) in a college is replaced by a 2 lamp HPT8 (49.3W).

$$\text{Mid life adjustment of } (56.4 - 49.3) / (87 - 49.3) = 19\%$$

$$\text{Applied after } (1/3 * 40000) / 3395 = 3.9 \text{ years}$$

The adjustment to be applied for each default measure described above is listed in the reference table below:

Savings Adjustment Factors

EE Measure Description	Savings Adjustment T12 EEmag ballast and 34 w lamps to HPT8	Savings Adjustment T12 EEmag ballast and 40 w lamps to HPT8	Savings Adjustment T12 mag ballast and 40 w lamps to HPT8
1-Lamp Relamp/Reballast T12 to HPT8	20%	22%	13%
2-Lamp Relamp/Reballast T12 to HPT8	40%	19%	15%
3-Lamp Relamp/Reballast T12 to HPT8	35%	16%	17%
4-Lamp Relamp/Reballast T12 to HPT8	31%	19%	18%

**MEASURE CODE: CI-LTG-T8FX-V09-200101**

**REVIEW DEADLINE: 1/1/2025**

## 4.5.4 LED Bulbs and Fixtures

### DESCRIPTION

Please note that this measure characterization contains assumptions that were negotiated as a compromise between the utilities and stakeholders. The Parties agree that from TRM version 11 does not allow utilities to claim General Service Lamp measure savings for business customers with longer than a 2 year measure life; though the Parties recognize that small businesses, disadvantaged businesses and non-profit entities often face challenges similar to Income Qualified customers.

This characterization provides savings assumptions for a variety of LED lamps including Omnidirectional (e.g., A-Type lamps), Decorative (e.g., Globes and Torpedoes), Directional (PAR Lamps, Reflectors, MR16), Mogul (E39, EX39), TLEDs and fixtures including refrigerated case, recessed and outdoor/garage fixtures.

If the implementation strategy does not allow for the installation location to be known, 100% Commercial targeted programs and 0% Residential targeted programs for LED Fixtures, Mogul LEDs and TLEDs should be used.<sup>1240</sup>

This measure was developed to be applicable to the following program types: TOS, NC, EREP, DI, KITS.

If applied to other program types, the measure savings should be verified.

### DEFINITION OF EFFICIENT EQUIPMENT

In order for this characterization to apply, new lamps must be ENERGY STAR in accordance with ENERGY STAR specification v2.1 (effective 1/2/2017) or equivalent to the most recent version of ENERGY STAR specifications or be listed on the Design Lights Consortium Qualifying Product List.<sup>1241</sup>

### DEFINITION OF BASELINE EQUIPMENT

The Standard Rx Program will assume a Time of Sale baseline for all one to one replacements, and early replacement for lighting redesign and early retirement for delamping.

For early replacement, the baseline is the existing fixture being replaced.

If the existing fixture is a T12: In July 14, 2012, Federal Standards were enacted that were expected to eliminate T-12s as an option for linear fluorescent fixtures. Through v3.0 of the TRM, it was assumed that the T-12 would no longer be baseline for retrofits from 1/1/2016. However, due to significant loopholes in the legislation, T-12 compliant product is still freely available and in Illinois T-12s continue to hold a significant share of the existing and replacement lamp market. From v8.0 on, a midlife adjustment is applied after the remaining useful life of the T12 fixture (calculated as 1/3 of the 40,000 hour ballast life/ hours). This assumes that T12 replacement lamps will continue to be available until then. See 'Early Replacement Measures with T12 baseline' section.

For Time of Sale, refer to the baseline tables at the end of this measure.

In 2012, Federal legislation stemming from the Energy Independence and Security Act of 2007 (EISA) required all general-purpose light bulbs (defined as omni-directional or standard A-lamps) between 40 watts and 100 watts to have ~30% increased efficiency, essentially phasing out standard incandescent technology. In 2012, the 100 w lamp standards went in to effect followed by the 75 w lamp standards in 2013 and 60 w and 40 w lamps in 2014.

Additionally, an EISA backstop provision was included that would require replacement baseline lamps to meet an efficacy requirement of 45 lumens/watt or higher beginning on 1/1/2020.

However, in December 2019, DOE issued a final determination for General Service Incandescent Lamps (GSILs), finding that this more stringent standard was not economically justified. However, in May 2022 DOE reversed this

---

<sup>1240</sup> Based on ComEd's Instant Discounts program CY2018, CY2019 and CY2020 (Rounds 1 and 2) Purchaser Survey analysis. See ComEd Instant Discounts Enduser Survey TRM Updates.xlsx. For Residential installations, hours of use assumptions from '5.5.6 LED Downlights' should be used for LED fixtures and '5.5.8 LED Screw Based Omnidirectional Bulbs' should be used for LED bulbs.

<sup>1241</sup> ENERGY STAR Program Requirements Product Specifications for Lamps (Light Bulbs), version 2.1, effective January 2, 2017.

decision by issuing a Final rule for both the broadened General Service Lamp definition as well as the implementation of the 45 lumen per watt backstop. DOE stated that it will use its enforcement discretion to minimize impacts on the supply chain and effectively allow companies to continue the manufacture and import of noncompliant bulbs through the remainder of 2022, and allow retailers to continue selling them with limited enforcement until July 2023.

As of 6/30/2023, no savings are claimed for screw based LED lamps or ENERGY STAR fixtures due to the EISA backstop unless installed in IQ common areas or via direct install programs. Direct Install programs where it can be shown that the LED is replacing working inefficient lighting should continue to use the existing inefficient lighting as baseline and also assume a measure life of 2 years.

#### **DEEMED LIFETIME OF EFFICIENT EQUIPMENT**

For interior fixtures, and Mogul LEDs, the lifetime is the life of the product, at the reported operating hours (lamp life in hours divided by operating hours per year – see reference table "LED component Costs and Lifetime." The analysis period is the same as the lifetime, capped at 15 years. (15 years from GDS Measure Life Report, June 2007).

For exterior fixtures, the lifetime is assumed to be 16 years for Dusk-to-Dawn (4303 hours) applications, or 25 years for Dusk-to-Business-Close Year Round (1609 hours) and Dusk-to-Business-Close Seasonal (<1000 hours).<sup>1242</sup>

For lamps impacted by the EISA backstop as indicated in tables below and LED Downlight Fixtures the measure life is assumed to be two years for direct install programs, unless installed in income qualified locations such as IQ common area lighting where a lifetime of 8 years should be used consistent with the residential measure assumption.

For lamps not impacted by the EISA backstop, the lifetime is calculated as the rated lifetime of the product (actual if available, otherwise assume 20,000 hours for Omnidirectional, 17,000 hours for decorative and 25,000 for directional lamps based on average rated life of lamps on the ENERGY STAR Qualified Products list (accessed 6/16/2020)) divided by the reported operating hours, capped at 10 years.<sup>1243</sup>

#### **DEEMED MEASURE COST**

Wherever possible, actual incremental costs should be used. Refer to reference table "LED component Cost & Lifetime" for defaults.

#### **LOADSHAPE**

- Loadshape C06 - Commercial Indoor Lighting
- Loadshape C07 - Grocery/Conv. Store Indoor Lighting
- Loadshape C08 - Hospital Indoor Lighting
- Loadshape C09 - Office Indoor Lighting
- Loadshape C10 - Restaurant Indoor Lighting
- Loadshape C11 - Retail Indoor Lighting
- Loadshape C12 - Warehouse Indoor Lighting
- Loadshape C13 - K-12 School Indoor Lighting
- Loadshape C14 - Indust. 1-shift (8/5) (e.g., comp. air, lights)
- Loadshape C15 - Indust. 2-shift (16/5) (e.g., comp. air, lights)
- Loadshape C16 - Indust. 3-shift (24/5) (e.g., comp. air, lights)

---

<sup>1242</sup> Exterior fixture measure lives are based upon review of the typical rated life of the fixtures, divided by the hours of use assumption and applying a derating factor of 15% to account for potential impacts from external installation (as proposed in a Guidehouse EUL methodology recommendation for Street Lights).

<sup>1243</sup> Based on recommendation in the Dunsky Energy Consulting, Livingston Energy Innovations and Opinion Dynamics Corporation; NEEP Emerging Technology Research Report, p 6-18.

- Loadshape C17 - Indust. 4-shift (24/7) (e.g., comp. air, lights)
- Loadshape C18 - Industrial Indoor Lighting
- Loadshape C19 - Industrial Outdoor Lighting
- Loadshape C20 - Commercial Outdoor Lighting
- Loadshape C60 – Non-Residential Agriculture Lighting – 6 Hours
- Loadshape C61 – Non-Residential Agriculture Lighting – 8 Hours
- Loadshape C62 – Non-Residential Agriculture Lighting – 12 Hours
- Loadshape C63 – Non-Residential Dairy Long Day Lighting – 17 Hours
- Loadshape C64 – Non-Residential Agriculture Lighting – 24 Hours

**COINCIDENCE FACTOR**

The summer peak coincidence factor for this measure is dependent on the location type. Values are provided for each building type in the reference section below.

**Algorithm**

**CALCULATION OF SAVINGS**

**ELECTRIC ENERGY SAVINGS**

$$\Delta kWh = ((Watts_{base} - Watts_{EE}) / 1000) * Hours * WHF_e * ISR * (1 - Leakage)$$

Where:

**Watts<sub>base</sub>** = Input wattage of the existing (for early replacement) or baseline system. Reference the “LED New and Baseline Assumptions” table for default values.

**Watts<sub>EE</sub>** = Actual wattage of LED purchased / installed. If unknown, use default provided below:  
 For ENERGY STAR rated lamps the following lumen equivalence tables should be used:<sup>1244</sup>

**Omnidirectional Lamps - ENERGY STAR Minimum Luminous Efficacy = 80Lm/W for <90 CRI lamps and 70Lm/W for >=90 CRI lamps.**

Minimum Lumens	Maximum Lumens	LED Wattage (WattsEE)	Baseline (WattsBase)	Delta Watts (WattsEE)	Impacted by EISA Backstop
120	309	4.0	25	21.0	No
310	399	4.0	25	21.0	Yes
400	749	6.6	29	22.4	Yes
750	899	9.6	43	33.4	Yes
900	1,399	13.1	53	39.9	Yes
1,400	1,999	16.0	72	56.0	Yes
2,000	2,999	21.8	150	128.2	Yes
3,000	3,299	28.9	200	171.1	Yes

<sup>1244</sup> See file “LED Lamp Updates 2021-06-09” for details on Guidehouse lamp wattage calculations based on equivalent baseline wattage and LED wattage of available ENERGY STAR product

Minimum Lumens	Maximum Lumens	LED Wattage (WattsEE)	Baseline (WattsBase)	Delta Watts (WattsEE)	Impacted by EISA Backstop
3,300	3,999	28.9	200	171.1	No
4,000	5,000	35.7	300	264.3	No

**Decorative Lamps - ENERGY STAR Minimum Luminous Efficacy = 65Lm/W for all lamps**

Bulb Type	Minimum Lumens	Maximum Lumens	LED Wattage (Watts <sub>EE</sub> )	Baseline (Watts <sub>Base</sub> )	Delta Watts (Watts <sub>EE</sub> )	Impacted by EISA Backstop
<b>Omni-Directional 3-Way</b>	1,100	1,999	14.7	100	85.3	Yes
	2,000	2,700	22.6	150	127.4	Yes
<b>Globe (medium and intermediate bases less than 750 lumens)</b>	150	309	3.0	25	22	No
	310	349	3.0	25	22	Yes
	350	499	4.7	40	35.3	Yes
	500	574	5.7	60	54.3	Yes
	575	649	6.5	75	68.5	Yes
	650	1,000	8.2	100	91.8	Yes
<b>Globe (candelabra bases less than 1050 lumens)</b>	150	309	3.5	25	21.5	No
	310	349	3.5	25	21.5	Yes
	350	499	4.4	40	35.6	Yes
	500	574	5.5	60	54.5	Yes
<b>Decorative (Shapes B, BA, C, CA, DC, F, G, medium and intermediate bases less than 750 lumens)</b>	160	299	2.6	25	22.4	No
	300	309	4.3	40	35.7	No
	310	499	4.3	40	35.7	Yes
	500	800	5.8	60	54.2	Yes
<b>Decorative (Shapes B, BA, C, CA, DC, F, G, T candelabra bases less than 1050 lumens)</b>	120	159	1.5	15	13.5	No
	160	299	2.7	25	22.3	No
	300	309	4.2	40	35.8	No
	310	499	4.2	40	35.8	Yes
	500	650	5.5	60	54.5	Yes
<b>Decorative (Shape ST)</b>	250	309	6.5	40	33.5	No
	310	499	6.5	40	33.5	Yes
	500	999	8.8	60	51.2	Yes
	1000	1500	10.0	100	90.0	Yes
<b>Decorative (Shape S)</b>	50	75	1.0	11	10.0	No
	100	120	1.2	15	13.8	No
	120	309	2.25	25	22.8	No
	310	340	2.25	25	22.8	Yes



**Directional Lamps** - ENERGY STAR Minimum Luminous Efficacy = 70lm/W for <90 CRI lamps and 61 Lm/W for >=90CRI lamps.

For Directional R, BR, ER, PAR, MR and MRX lamp types. Note the Center Beam Candle Power (CBCP) methodology described below the default table is the preferred methodology for PAR, MR and MRX lamps and should be used where data allows. Defaults for use when this information is not available are provided below:

Bulb Type	Minimum Lumens	Maximum Lumens	LED Wattage (Watts <sub>EE</sub> )	Baseline (Watts <sub>Base</sub> )	Delta Watts (Watts <sub>EE</sub> )	Impacted by EISA Backstop
Reflector lamp types with medium screw bases (PAR20, PAR30(S,L), PAR38, R40, etc.) w/ diameter >2.25" (*see exceptions below)	400	649	7.0	50	43	Yes
	650	899	10.7	75	64.3	Yes
	900	1,049	13.9	90	76.1	Yes
	1,050	1,199	13.8	100	86.2	Yes
	1,200	1,499	15.9	120	104.1	Yes
	1,500	1,999	18.9	150	131.1	Yes
	2,000	3,299	27.3	250	222.7	Yes
	3,300	4,200	27.3	250	222.7	No
Reflector lamp types with medium screw bases (PAR16, R14, R16, etc.) w/ diameter <2.25" (*see exceptions below)	280	309	4.6	35	30.4	No
	310	374	4.6	35	30.4	Yes
	375	600	6.4	50	43.6	Yes
*BR30, BR40, or ER40	650	949	9.3	65	55.7	Yes
	950	1,099	12.7	75	62.3	Yes
	1,100	1,399	14.4	85	70.6	Yes
	1,400	1,600	16.6	100	83.4	Yes
	1,601	1,800	22.2	120	97.8	Yes
*R20	450	524	6.0	40	34.0	Yes
	525	750	7.1	45	37.9	Yes
*MR16	250	309	3.8	20.0	16.2	No
	310	324	3.8	20.0	16.2	Yes
	325	369	4.8	25.0	20.2	Yes
	370	400	4.9	25.0	20.1	Yes

For PAR, MR, and MRX Lamps Types:

For these highly focused directional lamp types, it is necessary to have Center Beam Candle Power (CBCP) and beam angle measurements to accurately estimate the equivalent baseline wattage. The formula below is based on the Energy Star Center Beam Candle Power tool.<sup>1245</sup> If CBCP and beam angle information are

<sup>1245</sup> ENERGY STAR Lamps Center Beam Intensity Benchmark Tool and Calculator

not available or if the equation below returns a negative value (or undefined), use the manufacturer’s recommended baseline wattage equivalent.<sup>1246</sup>

Wattsbase =

$$375.1 - 4.355(D) - \sqrt{227,800 - 937.9(D) - 0.9903(D^2) - 1479(BA) - 12.02(D * BA) + 14.69(BA^2) - 16,720 * \ln(CBCP)}$$

Where:

- D = Bulb diameter (e.g. for PAR20 D = 20)
- BA = Beam angle
- CBCP = Center beam candle power

The result of the equation above should be rounded DOWN to the nearest wattage established by Energy Star:

Diameter	Permitted Wattages
16	20, 35, 40, 45, 50, 60, 75
20	50
30S	40, 45, 50, 60, 75
30L	50, 75
38	40, 45, 50, 55, 60, 65, 75, 85, 90, 100, 120, 150, 250

Additional bulb types:

Bulb Type	Minimum Lumens	Maximum Lumens	LED Wattage (Watts <sub>EE</sub> )	Baseline (Watts <sub>Base</sub> )	Delta Watts (Watts <sub>EE</sub> )	Impacted by EISA Backstop
<b>Dimmable Twist, Globe (less than 5" in diameter and &gt; 749 lumens), candle (shapes B, BA, CA &gt; 749 lumens), Candelabra Base Lamps (&gt;1049 lumens), Intermediate Base Lamps (&gt;749 lumens)</b>	120	309	4.0	25	21.0	No
	310	399	4.0	25	21.0	Yes
	400	749	6.6	29	22.4	Yes
	750	899	9.6	43	33.4	Yes
	900	1,399	13.1	53	39.9	Yes
	1,400	1,999	16.0	72	56.0	Yes

Hours = Average hours of use per year are provided in the Reference Table in Section 4.5 for each building type. For Mogul LEDs, use fixture annual operating hours. If unknown, use the Miscellaneous value.

WHFe = Waste heat factor for energy to account for cooling energy savings from efficient lighting are provided below for each building type in the Reference Table in Section 4.5. If unknown, use the Miscellaneous value.

ISR = In Service Rate -the percentage of units rebated that actually get installed.

<sup>1246</sup> The Energy Star Center Beam Candle Power tool does not accurately model baseline wattages for lamps with certain bulb characteristic combinations – specifically for lamps with very high CBCP.

=100% if application form completed with sign off that equipment is not placed into storage.<sup>1247</sup> If sign off form not completed, assume the following ISR assumptions, if program survey data is not available:

Type	1st year In Service Rate (ISR) <sup>1248</sup>
LED Bulbs and Mogul LEDs	97.9% <sup>1249</sup>
LED Fixtures (Energy Star Fixtures)	98.0% <sup>1250</sup>
Efficiency Kits	92.9% <sup>1251</sup>

Type	Weighted Average 1st year In Service Rate (ISR)	2nd year Installations	3rd year Installations	Final Lifetime In Service Rate
TLEDs	83.1% <sup>1252</sup>	8.1%	6.8%	98.0%

Leakage = Adjustment to account for the percentage of program bulbs that move out (and in if deemed appropriate)<sup>1253</sup> of the Utility Jurisdiction.

Midstream (TOS) Lighting programs = Use deemed assumptions below:<sup>1254</sup>

ComEd: 0.31%  
 Ameren: 0%<sup>1255</sup>

<sup>1247</sup> Illinois evaluation of PY1 through PY3 has not found that fixtures or lamps placed into storage to be a significant enough issue to warrant including an “In-Service Rate” when commercial customers complete an application form.

<sup>1248</sup> In Service Rates now represent the lifetime In Service Rates with the second and third year installations discounted by the Real Discount Rate of 0.46%. Lifetime ISR assumptions for efficiency kits are based upon Residential direct mailed kits. For all other programs Tthe 98% Lifetime ISR assumption is based upon the standard CFL measure in the absence of any better reference. This value is based upon review of two evaluations:

‘Nexus Market Research, RLW Analytics and GDS Associates study; “New England Residential Lighting Markdown Impact Evaluation, January 20, 2009’ and ‘KEMA Inc, Feb 2010, Final Evaluation Report:, Upstream Lighting Program, Volume 1.’ This implies that only 2% of bulbs purchased are never installed. The second and third year installations are based upon Ameren analysis of the Californian KEMA study showing that 54% of future installs occur in year 2 and 46% in year 3.

<sup>1249</sup> Based on ComEd’s Instant Discounts program CY2019 and CY2020 (Rounds 1 and 2) Purchaser Survey analysis. See ComEd Instant Discounts Enduser Survey TRM Updates.xlsx

<sup>1250</sup> Based on ComEd’s Instant Discounts program CY2019 and CY2020 (Rounds 1 and 2) Purchaser Survey analysis. See ComEd Instant Discounts Enduser Survey TRM Updates.xlsx

<sup>1251</sup> First year ISR is average ISR from CY2018, CY2019 and CY2020 ComEd Small Business Kit participant installation surveys. Please see file “SB Kits Survey Analysis TRMv10 Support.xlsx”

<sup>1252</sup> Based on ComEd’s Instant Discounts program CY2019 and CY2020 (Rounds 1 and 2) Purchaser Survey analysis. See ComEd Instant Discounts Enduser Survey TRM Updates.xlsx

<sup>1253</sup> Leakage in is only appropriate to credit to IL utility program savings if it is reasonably expected that the IL utility program marketing efforts played an important role in influencing customer to purchase the light bulbs. Furthermore, consideration that such customers might be free riders should be addressed. If leakage in is assessed, efforts should be made to ensure no double counting of savings occurs if the evaluation is estimating both leakage in and spillover savings of light bulbs.

<sup>1254</sup> Leakage rate is based upon review of PY9-CY2021 evaluations from ComEd.

<sup>1255</sup> Per Ameren staff, all incentivized non-residential LED bulbs and fixtures are required to show proof of being an Ameren customer and thus the leakage is 0%.

All other programs = 0%

**Mid Life Baseline Adjustment**

Early Replacement Measures with T12 Baseline

For early replacement measures replacing existing T12 fixtures the full savings (as calculated above in the Algorithm section) will be claimed for the remaining useful life of the T12 fixture. This should be calculated as follows:

$$\text{RUL of existing T12 fixture} = (1/3 * 40,000)/\text{Hours}$$

A savings adjustment should then be applied to the annual savings for the remainder of the measure life. The adjustment factor to be applied for each T12 installation is 57%.<sup>1256</sup>

For example, for an existing 68W T12 fixture in a college is replaced by a 3000 lumen LED 2x2 Recessed Light Fixture (25.4W), a mid life adjustment of 57% should be applied after  $(1/3 * 40000)/3395 = 3.9$  years.

**HEATING PENALTY**

If electrically heated building:

$$\Delta \text{kWh}_{\text{heatpenalty}}^{1257} = (((\text{WattsBase} - \text{WattsEE}) / 1000) * \text{ISR} * \text{Hours} * -\text{IFkWh})$$

Where:

IFkWh = Lighting-HVAC Interaction Factor for electric heating impacts; this factor represents the increased electric space heating requirements due to the reduction of waste heat rejected by the efficient lighting. Values are provided in the Reference Table in Section 4.5. If unknown, use the Miscellaneous value.

**For example**, a 9W LED omnidirectional lamp, 450 lumens, is installed in a heat pump heated office in 2014 and sign off form provided:

$$\begin{aligned} \Delta \text{kWh}_{\text{heatpenalty}} &= ((29 - 6.7) / 1000) * 1.0 * 3088 * -0.151 \\ &= - 10.4 \text{ kWh} \end{aligned}$$

**DEFERRED INSTALLS**

As presented above, if a sign off form is not completed the characterization assumes that a percentage of T-LED bulbs purchased are not installed until Year 2 and Year 3 (see ISR assumption above). The Illinois Technical Advisory Committee has determined the following methodology for calculating the savings of these future installs.

Year 1 (Purchase Year) installs: Characterized using assumptions provided above or evaluated assumptions if available.

Year 2 and 3 installs: Characterized using delta watts assumption and hours of use from the Install Year, i.e., the actual deemed (or evaluated if available) assumptions active in Year 2 and 3 should be applied.

<sup>1256</sup> The appropriate T12 midlife adjustment factor was developed by the TAC Lighting Working Group. The results of a 2019 ComEd study provided survey response data on the planned replacement upon the burnout of a T12 ballast. This was adjusted by first year NTG to remove first year freeriders and therefore estimate what the non-freerider population would do at the end of T12 life. See "Linear Forecast Workbook\_2020.xls" for information on calculation.

<sup>1257</sup> Negative value because this is an increase in heating consumption due to the efficient lighting.

The NTG factor for the Purchase Year should be applied.

**SUMMER COINCIDENT PEAK DEMAND SAVINGS**

$$\Delta kW = ((Watts_{base} - Watts_{EE}) / 1000) * ISR * WHF_d * CF$$

Where:

- WHFd = Waste Heat Factor for Demand to account for cooling savings from efficient lighting in cooled buildings is provided in Reference Table in Section 4.5. If unknown, use the Miscellaneous value.
- CF = Summer Peak Coincidence Factor for measure is provided in the Reference Table in Section 4.5. If unknown, use the Miscellaneous value.

**For example**, a 9W LED omnidirectional lamp, 450 lumens, is installed in an office in 2014 and sign off form provided:

$$\Delta kW = ((29 - 6.7) / 1000) * 1.0 * 1.3 * 0.66$$

**FOSSIL FUEL SAVINGS**

Heating Penalty if fossil fuel heated building (or if heating fuel is unknown):

$$\Delta Therms = ((Watts_{Base} - Watts_{EE}) / 1000) * ISR * Hours * - IFTherms$$

Where:

- IFTherms = Lighting-HVAC Integration Factor for gas heating impacts; this factor represents the increased gas space heating requirements due to the reduction of waste heat rejected by the efficient lighting. Values are provided in the Reference Table in Section 4.5. If unknown, use the Miscellaneous value.

**For example**, a 9W LED omnidirectional lamp, 450 lumens, is installed in an office in 2014 and sign off form provided:

$$\begin{aligned} \Delta Therms &= ((29 - 6.7) / 1000) * 1.0 * 3088 * -0.016 \\ &= - 1.10 \text{ therms} \end{aligned}$$

**WATER IMPACT DESCRIPTIONS AND CALCULATION**

N/A

**DEEMED O&M COST ADJUSTMENT CALCULATION**

For fixture measures, the individual component lifetimes and costs are provided in the reference table section below.<sup>1258</sup>

For lamps no O&M costs should be applied.

**REFERENCE TABLES**

**LED Bulb Assumptions**

<sup>1258</sup> See IL LED Lighting Systems TRM Reference Tables\_2018.xlsx for breakdown of component cost assumptions.

Wherever possible, actual incremental costs should be used. If unavailable assume the following incremental costs:<sup>1259</sup>

Bulb Type	Year	LED	Incandescent	Incremental Cost
<b>Omnidirectional</b>	2017	\$3.21	\$1.25	\$1.96
	2018	\$3.21		\$1.96
	2019	\$3.11		\$1.86
	2020	\$2.70		\$1.45
<b>Directional</b>	2017	\$6.24	\$3.53	\$2.71
	2018+	\$5.18		\$1.65
<b>Decorative and Globe</b>	2017	\$3.50	\$1.60	\$1.90
	2018+	\$3.40	\$1.74	\$1.66

**LED Fixture Wattage, TOS Baseline and Incremental Cost Assumptions<sup>1260</sup>**

LED Category	EE Measure Description	Watts <sub>EE</sub>	Baseline Description	Watts <sub>BASE</sub>	Incremental Cost
LED Downlight Fixtures* Impacted by EISA Backstop – apply 2 year measure life (or 8 years if IQ)	LED Recessed, Surface, Pendant Downlights	17.6	Baseline Recessed, Surface, Pendant Downlights	54.3	\$27
LED Interior Directional	LED Track Lighting	12.2	Baseline Track Lighting	60.4	\$59
	LED Wall-Wash Fixtures	8.3	Baseline Wall-Wash Fixtures	17.7	\$59
LED Display Case <sup>1261</sup>	LED Display Case Light Fixture	4 per ft	Baseline Display Case Light Fixture	36.2 per ft	\$11/ft
	LED Undercabinet Shelf-Mounted Task Light Fixtures	4 per ft	Baseline Undercabinet Shelf-Mounted Task Light Fixtures	36.2 per ft	\$11/ft
	LED Refrigerated Case Light, Horizontal or Vertical	4 per ft	Baseline Refrigerated Case Light, Horizontal or Vertical (per foot)	15.2 per ft	\$11/ft

<sup>1259</sup> Baseline and LED lamp costs are based on field data collected by CLEAResult and provided by ComEd. See ComEd Pricing Projections 06302016.xlsx for analysis. Given LED prices are expected to continue declining assumed costs should be reassessed on an annual basis and replaced with IL specific LED program information when available.

<sup>1260</sup> Watt assumptions for efficient measures are based upon the average wattage of each fixture type/lumen range from the Design Light Consortium (DLC) Qualifying Product Lists alongside past Efficiency Vermont projects and PGE refrigerated case study. Watt, lumen, lamp life, and ballast factor assumptions for baseline fixtures are based upon manufacturer specification sheets. Baseline cost data comes from lighting suppliers, past Efficiency Vermont projects, and professional judgment. Efficient cost data comes from 2012 DOE “Energy Savings Potential of Solid-State Lighting in General Illumination Applications”, Table A.1. See “LED Lighting Systems TRM Reference Tables\_2018.xlsx” for more information and specific product links.

<sup>1261</sup> LED Case Lighting is based on an average of DLC Horizontal and Vertical Lighting less than 80 W. This filter was intended to exclude vaportight fixtures from the average. The horizontal and vertical averages, provided by Guidehouse in 5/2020, were 4.1 W/ft and 3.7 W/ft, respectively.

LED Category	EE Measure Description	Watts <sub>EE</sub>	Baseline Description	Watts <sub>BASE</sub>	Incremental Cost
	LED Freezer Case Light, Horizontal or Vertical	4 per ft	Baseline Freezer Case Light, Horizontal or Vertical (per foot)	18.7 per ft	\$11/ft
LED Linear Replacement Lamps	T8 LED Replacement Lamp (TLED), < 1200 lumens	8.6	F17T8 Standard Lamp - 2 foot	15.0	\$13
	T8 LED Replacement Lamp (TLED), 1200-2400 lumens	13.7	F32T8 Standard Lamp - 4 foot	28.2	\$15
	T8 LED Replacement Lamp (TLED), > 2400 lumens	24.7	F32T8/HO Standard Lamp - 4 foot	41.8	\$13
LED Troffers	LED 2x2 Recessed Light Fixture, 2000-3500 lumens	22.4	2-Lamp 32w T8 (BF < 0.89)	57.0	\$53
	LED 2x2 Recessed Light Fixture, 3501-5000 lumens	34.2	3-Lamp 32w T8 (BF < 0.88)	84.5	\$69
	LED 2x4 Recessed Light Fixture, 3000-4500 lumens	29.9	2-Lamp 32w T8 (BF < 0.89)	57.0	\$55
	LED 2x4 Recessed Light Fixture, 4501-6000 lumens	42.1	3-Lamp 32w T8 (BF < 0.88)	84.5	\$76
	LED 2x4 Recessed Light Fixture, 6001-7500 lumens	51.5	4-Lamp 32w T8 (BF < 0.88)	112.6	\$104
	LED 1x4 Recessed Light Fixture, 1500-3000 lumens	19.2	1-Lamp 32w T8 (BF < 0.91)	29.1	\$22
	LED 1x4 Recessed Light Fixture, 3001-4500 lumens	30.8	2-Lamp 32w T8 (BF < 0.89)	57.0	\$75
	LED 1x4 Recessed Light Fixture, 4501-6000 lumens	40.2	3-Lamp 32w T8 (BF < 0.88)	84.5	\$83
LED Linear Ambient Fixtures	LED Surface & Suspended Linear Fixture, <= 3000 lumens	17.6	1-Lamp 32w T8 (BF < 0.91)	29.1	\$10
	LED Surface & Suspended Linear Fixture, 3001-4500 lumens	28.0	2-Lamp 32w T8 (BF < 0.89)	57.0	\$52
	LED Surface & Suspended Linear Fixture, 4501-6000 lumens	39.2	3-Lamp 32w T8 (BF < 0.88)	84.5	\$78
	LED Surface & Suspended Linear	49.9	T5HO 2L-F54T5HO - 4'	120.0	\$131

LED Category	EE Measure Description	Watts <sub>EE</sub>	Baseline Description	Watts <sub>BASE</sub>	Incremental Cost
	Fixture, 6001-7500 lumens				
	LED Surface & Suspended Linear Fixture, > 7500 lumens	90.6	T5HO 3L-F54T5HO - 4'	180.0	\$173
LED High & Low Bay Fixtures	LED Low-Bay Fixtures, <= 10,000 lumens	51.8	3-Lamp T8HO Low-Bay	157.0	\$42.88
	LED High-Bay Fixtures, 10,001-15,000 lumens	89.2	4-Lamp T8HO High-Bay	196.0	\$31.94
	LED High-Bay Fixtures, 15,001-20,000 lumens	118.5	6-Lamp T8HO High-Bay	294.0	\$61.17
	LED High-Bay Fixtures, 20,001-30,000 lumens	171.4	8-Lamp T8HO High-Bay	392.0	\$51.11
	LED High-Bay Fixtures, 30,001-40,000 lumens	230.5	750 Watts Metal Halide	850	\$113.60
	LED High-Bay Fixtures 40,001-50,000 lumens	306.2	1000 Watts Metal Halide	1080	\$166.55
	LED High-Bay Fixtures >50,000 lumens	443.7	1500 Watts Metal Halide	1610	\$283.67
LED Agricultural Interior Fixtures	LED Ag Interior Fixtures, <= 2,000 lumens	12.9	1-Lamp 32w T8 (BF <0.91)	29.1	\$18
	LED Ag Interior Fixtures, 2,001-4,000 lumens	29.7	2-Lamp 32w T8 (BF < 0.89)	57	\$48
	LED Ag Interior Fixtures, 4,001-6,000 lumens	45.1	25% 217 Watt EISA Inc, 75% 3L T8	121.0	\$57
	LED Ag Interior Fixtures, 6,001-8,000 lumens	59.7	25% 292 Watt EISA Inc, 75% 4L T8	159.0	\$88
	LED Ag Interior Fixtures, 8,001-12,000 lumens	84.9	200W Pulse Start Metal Halide	227.3	\$168
	LED Ag Interior Fixtures, 12,001-16,000 lumens	113.9	320W Pulse Start Metal Halide	363.6	\$151
	LED Ag Interior Fixtures, 16,001-20,000 lumens	143.7	350W Pulse Start Metal Halide	397.7	\$205



LED Category	EE Measure Description	Watts <sub>EE</sub>	Baseline Description	Watts <sub>BASE</sub>	Incremental Cost
	LED Ag Interior Fixtures, > 20,000 lumens	193.8	(2) 320W Pulse Start Metal Halide	727.3	\$356
LED Exterior Fixtures	LED Exterior Fixtures, <= 5,000 lumens	27.5	100W Metal Halide	113.6	\$97
	LED Exterior Fixtures, 5,001-10,000 lumens	57.6	175W Pulse Start Metal Halide	198.9	\$123.81
	LED Exterior Fixtures, 10,001-15,000 lumens	94.9	250W Pulse Start Metal Halide	284.1	\$134.35
	LED Exterior Fixtures, 15,001-30,000 lumens	161.3	400W Pulse Start Metal Halide	454.5	\$196.16
	LED Exterior Fixtures, 30,001-40,000 lumens	253.9	750 W Metal Halide	850	\$238.18
	LED Exterior Fixtures, 40,001-50,000 lumens	319.6	1000 W Metal Halide	1080	\$319.31
	LED Exterior Fixtures, > 50,000 lumens	585.9	1500 W Metal Halide	1610	\$1094.74
LED Mogul Base HID Replacement Lamps (if unknown, assume Type B)	LED Mogul Base HID Replacement Lamp, <= 5,000 lumens	31	100W Metal Halide	100 (Type A) 113.6 (Type B)	\$68
	LED Mogul Base HID Replacement Lamp, 5,001-10,000 lumens	64	175W Pulse Start Metal Halide	175 (Type A) 198.9 (Type B)	\$60
	LED Mogul Base HID Replacement Lamp, 10,001-15,000 lumens	101	250W Pulse Start Metal Halide	250 (Type A) 284.1 (Type B)	\$129
	LED Mogul Base HID Replacement Lamp, 15,001-30,000 lumens	141	400W Pulse Start Metal Halide	400 (Type A) 454.5 (Type B)	\$156
	LED Mogul Base HID Replacement Lamp, 30,001-40,000 lumens	236	750 W Metal Halide	750 (Type A) 850 (Type B)	\$446
	LED Mogul Base HID Replacement Lamp, > 40,000 lumens	295	1000 W Metal Halide	1000 (Type A) 1080 (Type B)	\$629

**LED Fixture Component Costs & Lifetime<sup>1262</sup>**

<sup>1262</sup> Note that some measures have blended baselines (T12:T8 18:82). All values are provided to enable calculation of appropriate O&M impacts. Total costs include lamp, labor and disposal cost assumptions where applicable, see IL LED Lighting Systems TRM Reference Tables\_2018.xlsx for more information.

LED Category	EE Measure Description	EE Measure				Baseline			
		Lamp Life (hrs)	Total Lamp Replacement Cost	LED Driver Life (hrs)	Total LED Driver Replacement Cost	Lamp Life (hrs)	Total Lamp Replacement Cost	Ballast Life (hrs)	Total Lamp Replacement Cost
LED Downlight Fixtures	LED Recessed, Surface, Pendant Downlights	50,000	\$30.75	70,000	\$47.50	2,500	\$8.86	40,000	\$14.17
LED Interior Directional	LED Track Lighting	50,000	\$39.00	70,000	\$47.50	2,500	\$12.71	40,000	\$11.17
	LED Wall-Wash Fixtures	50,000	\$39.00	70,000	\$47.50	2,500	\$9.17	40,000	\$27.50
LED Display Case	LED Display Case Light Fixture	50,000	\$9.75/ft	70,000	\$11.88/ft	2,500	\$6.70	40,000	\$5.00
	LED Undercabinet Shelf-Mounted Task Light Fixtures	50,000	\$9.75/ft	70,000	\$11.88/ft	2,500	\$6.70	40,000	\$5.00
	LED Refrigerated Case Light, Horizontal or Vertical	50,000	\$8.63/ft	70,000	\$9.50/ft	15,000	\$1.13	40,000	\$8.00
	LED Freezer Case Light, Horizontal or Vertical	50,000	\$7.88/ft	70,000	\$7.92/ft	12,000	\$0.94	40,000	\$6.00
LED Linear Replacement Lamps	T8 LED Replacement Lamp (TLED), < 1200 lumens	50,000	\$5.76	70,000	\$13.67	30,000	\$6.17	40,000	\$11.00
	T8 LED Replacement Lamp (TLED), 1200-2400 lumens	50,000	\$8.57	70,000	\$13.67	24,000	\$6.17	40,000	\$11.00
	T8 LED Replacement Lamp (TLED), > 2400 lumens	50,000	\$8.57	70,000	\$13.67	18,000	\$6.17	40,000	\$11.00
LED Troffers	LED 2x2 Recessed Light Fixture, 2000-3500 lumens	50,000	\$78.07	70,000	\$40.00	24,000	\$26.33	40,000	\$35.00
	LED 2x2 Recessed Light Fixture, 3501-5000 lumens	50,000	\$89.23	70,000	\$40.00	24,000	\$39.50	40,000	\$35.00
	LED 2x4 Recessed Light Fixture, 3000-4500 lumens	50,000	\$96.10	70,000	\$40.00	24,000	\$12.33	40,000	\$35.00
	LED 2x4 Recessed Light Fixture, 4501-6000 lumens	50,000	\$114.37	70,000	\$40.00	24,000	\$18.50	40,000	\$35.00
	LED 2x4 Recessed Light Fixture, 6001-7500 lumens	50,000	\$137.43	70,000	\$40.00	24,000	\$24.67	40,000	\$35.00
	LED 1x4 Recessed Light Fixture, 1500-3000 lumens	50,000	\$65.43	70,000	\$40.00	24,000	\$6.17	40,000	\$35.00

LED Category	EE Measure Description	EE Measure				Baseline			
		Lamp Life (hrs)	Total Lamp Replacement Cost	LED Driver Life (hrs)	Total LED Driver Replacement Cost	Lamp Life (hrs)	Total Lamp Replacement Cost	Ballast Life (hrs)	Total Lamp Replacement Cost
	LED 1x4 Recessed Light Fixture, 3001-4500 lumens	50,000	\$100.44	70,000	\$40.00	24,000	\$12.33	40,000	\$35.00
	LED 1x4 Recessed Light Fixture, 4501-6000 lumens	50,000	\$108.28	70,000	\$40.00	24,000	\$18.50	40,000	\$35.00
LED Linear Ambient Fixtures	LED Surface & Suspended Linear Fixture, <= 3000 lumens	50,000	\$62.21	70,000	\$40.00	24,000	\$6.17	40,000	\$35.00
	LED Surface & Suspended Linear Fixture, 3001-4500 lumens	50,000	\$93.22	70,000	\$40.00	24,000	\$12.33	40,000	\$35.00
	LED Surface & Suspended Linear Fixture, 4501-6000 lumens	50,000	\$114.06	70,000	\$40.00	24,000	\$18.50	40,000	\$35.00
	LED Surface & Suspended Linear Fixture, 6001-7500 lumens	50,000	\$152.32	70,000	\$40.00	30,000	\$26.33	40,000	\$60.00
	LED Surface & Suspended Linear Fixture, > 7500 lumens	50,000	\$183.78	70,000	\$40.00	30,000	\$39.50	40,000	\$60.00
LED High & Low Bay Fixtures	LED Low-Bay Fixtures, <= 10,000 lumens	50,000	\$90.03	70,000	\$62.50	18,000	\$64.50	40,000	\$92.00
	LED High-Bay Fixtures, 10,001-15,000 lumens	50,000	\$122.59	70,000	\$62.50	18,000	\$86.00	40,000	\$92.00
	LED High-Bay Fixtures, 15,001-20,000 lumens	50,000	\$157.22	70,000	\$62.50	18,000	\$129.00	40,000	\$114.00
	LED High-Bay Fixtures, 20,001 – 30,000 lumens	50,000	\$228.52	70,000	\$62.50	18,000	\$172.00	40,000	\$144.00
	LED High-Bay Fixtures, 30,001-40,000 lumens	50,000	\$294.00	70,000	\$62.50	15,000	\$82.00	40,000	\$144.00
	LED High-Bay Fixtures, 40,001-50,000 lumens	50,000	\$324.00	70,000	\$62.50	15,000	\$88.00	40,000	\$144.00

LED Category	EE Measure Description	EE Measure				Baseline			
		Lamp Life (hrs)	Total Lamp Replacement Cost	LED Driver Life (hrs)	Total LED Driver Replacement Cost	Lamp Life (hrs)	Total Lamp Replacement Cost	Ballast Life (hrs)	Total Lamp Replacement Cost
	LED High-Bay Fixtures, > 50,000 lumens	50,000	\$382.00	70,000	\$62.50	15,000	\$96.00	40,000	\$200.00
LED Agricultural Interior Fixtures	LED Ag Interior Fixtures, <= 2,000 lumens	50,000	\$41.20	70,000	\$40.00	1,000	\$1.23	40,000	\$26.00
	LED Ag Interior Fixtures, 2,001-4,000 lumens	50,000	\$65.97	70,000	\$40.00	1,000	\$1.43	40,000	\$26.00
	LED Ag Interior Fixtures, 4,001-6,000 lumens	50,000	\$80.08	70,000	\$40.00	1,000	\$1.62	40,000	\$26.00
	LED Ag Interior Fixtures, 6,001-8,000 lumens	50,000	\$105.54	70,000	\$40.00	1,000	\$1.81	40,000	\$26.00
	LED Ag Interior Fixtures, 8,001-12,000 lumens	50,000	\$179.81	70,000	\$62.50	15,000	\$63.00	40,000	\$110.00
	LED Ag Interior Fixtures, 12,001-16,000 lumens	50,000	\$190.86	70,000	\$62.50	15,000	\$68.00	40,000	\$120.00
	LED Ag Interior Fixtures, 16,001-20,000 lumens	50,000	\$237.71	70,000	\$62.50	15,000	\$73.00	40,000	\$130.00
	LED Ag Interior Fixtures, > 20,000 lumens	50,000	\$331.73	70,000	\$62.50	15,000	\$136.00	40,000	\$200.00
LED Exterior Fixtures	LED Exterior Fixtures, <= 5,000 lumens	50,000	\$73.80	70,000	\$62.50	15,000	\$58.00	40,000	\$100.00
	LED Exterior Fixtures, 5,001-10,000 lumens	50,000	\$124.89	70,000	\$62.50	15,000	\$63.00	40,000	\$110.00
	LED Exterior Fixtures, 10,001-15,000 lumens	50,000	\$214.95	70,000	\$62.50	15,000	\$68.00	40,000	\$120.00
	LED Exterior Fixtures, 15,000- 30,000 lumens	50,000	\$321.06	70,000	\$62.50	15,000	\$73.00	40,000	\$130.00
	LED Exterior Fixtures, 30,001-40,000 lumens	50,000	\$546.00	70,000	\$62.50	15,000	\$82.00	40,000	\$140.00
	LED Exterior Fixtures, 40,001-50,000 lumens	50,000	\$722.00	70,000	\$62.50	15,000	\$88.00	40,000	\$140.00
	LED Exterior Fixtures, > 50,000 lumens	50,000	\$870.00	70,000	\$62.50	15,000	\$96.00	40,000	\$200.00

LED Category	EE Measure Description	EE Measure				Baseline			
		Lamp Life (hrs)	Total Lamp Replacement Cost	LED Driver Life (hrs)	Total LED Driver Replacement Cost	Lamp Life (hrs)	Total Lamp Replacement Cost	Ballast Life (hrs)	Total Replacement Cost
LED Mogul Base HID Replacement Lamps	LED Mogul Base HID Replacement Lamp, <= 5,000 lumens	50,000	\$108.00	70,000	\$62.50	15,000	\$40.00	40,000	\$92.50
	LED Mogul Base HID Replacement Lamp, 5,001-10,000 lumens	50,000	\$99.00	70,000	\$62.50	15,000	\$39.00	40,000	\$92.50
	LED Mogul Base HID Replacement Lamp, 10,001-15,000 lumens	50,000	\$179.00	70,000	\$62.50	15,000	\$50.00	40,000	\$111.50
	LED Mogul Base HID Replacement Lamp, 15,001-30,000 lumens	50,000	\$210.00	70,000	\$62.50	15,000	\$54.00	40,000	\$141.50
	LED Mogul Base HID Replacement Lamp, 30,001-40,000 lumens	50,000	\$514.00	70,000	\$62.50	15,000	\$68.00	40,000	\$141.50
	LED Mogul Base HID Replacement Lamp, > 40,000 lumens	50,000	\$707.00	70,000	\$62.50	15,000	\$78.00	40,000	\$141.50

**MEASURE CODE: CI-LTG-LEDB-V17-240101**

**REVIEW DEADLINE: 1/1/2026**

## 4.5.5 Commercial LED Exit Signs

### DESCRIPTION

This measure characterizes the savings associated with installing a Light Emitting Diode (LED) exit sign in place of a fluorescent or incandescent exit sign in a Commercial building. Light Emitting Diode exit signs have a string of very small, typically red or green, glowing LEDs arranged in a circle or oval. The LEDs may also be arranged in a line on the side, top or bottom of the exit sign. LED exit signs provide the best balance of safety, low maintenance, and very low energy usage compared to other exit sign technologies.

This measure was developed to be applicable to the following program types: RF.

If applied to other program types, the measure savings should be verified.

### DEFINITION OF EFFICIENT EQUIPMENT

The efficient equipment is assumed to be an exit sign illuminated by LEDs.

### DEFINITION OF BASELINE EQUIPMENT

The baseline equipment is assumed to be an existing fluorescent or incandescent model.

### DEEMED LIFETIME OF EFFICIENT EQUIPMENT

The measure life is assumed to be 5 years.<sup>1263</sup>

### DEEMED MEASURE COST

The actual material and labor costs should be used if available. If actual costs are unavailable, assume a total installed cost of at \$32.50.<sup>1264</sup>

### LOADSHAPE

Loadshape C53 - Flat

### COINCIDENCE FACTOR

The summer peak coincidence factor for this measure is assumed to be 100%.<sup>1265</sup>

---



---

### Algorithm

---

### CALCULATION OF SAVINGS

#### ELECTRIC ENERGY SAVINGS

$$\Delta kWh = ((WattsBase - WattsEE) / 1000) * HOURS * WHF_e$$

Where:

WattsBase = Actual wattage if known, if unknown assume the following:

Baseline Type	Watts <sub>Base</sub>
Incandescent	35W <sup>1266</sup>

<sup>1263</sup> Estimate of remaining life of existing unit being replaced.

<sup>1264</sup> Price includes new exit sign/fixture and installation. LED exit sign cost/unit is \$22.50 based on the NYSERDA Deemed Savings Database and review of LED exit signs available as of April 2023, and assuming IL labor cost of 15 minutes @ \$40/hr.

<sup>1265</sup> Assuming continuous operation of an LED exit sign, the Summer Peak Coincidence Factor is assumed to equal 1.0.

<sup>1266</sup> Based on review of available product.

Baseline Type	Watts <sub>Base</sub>
CFL (dual sided)	14W <sup>1267</sup>
CFL (single sided)	7W
Unknown	7W

WattsEE = Actual wattage if known, if unknown assume 2W for single sided or unknown type and 4W for dual sided<sup>1268</sup>

HOURS = Annual operating hours  
= 8766

WHF<sub>e</sub> = Waste heat factor for energy to account for cooling energy savings from efficient lighting are provided for each building type in the Reference Table in Section 4.5. If unknown, use the Miscellaneous value.

**For example**, replacing incandescent fixture in an office:

$$\begin{aligned} \Delta\text{kWh} &= ((35 - 2)/1000) * 8766 * 1.25 \\ &= 362 \text{ kWh} \end{aligned}$$

Replacing single sided fluorescent fixture in a hospital:

$$\begin{aligned} \Delta\text{kWh} &= ((7 - 2)/1000) * 8766 * 1.35 \\ &= 59.2 \text{ kWh} \end{aligned}$$

### HEATING PENALTY

If electrically heated building:

$$\Delta\text{kWh}_{\text{heatpenalty}}^{1269} = (((\text{WattsBase} - \text{WattsEE})/1000) * \text{Hours} * -\text{IFkWh})$$

Where:

IFkWh = Lighting-HVAC Interaction Factor for electric heating impacts; this factor represents the increased electric space heating requirements due to the reduction of waste heat rejected by the efficient lighting. Values are provided in the Reference Table in Section 4.5. If unknown, use the Miscellaneous value.

**For example**, replacing incandescent fixture in a heat pump heated office:

$$\begin{aligned} \Delta\text{kWh}_{\text{heatpenalty}} &= ((35 - 2)/1000) * 8766 * -0.151 \\ &= -43.7 \text{ kWh} \end{aligned}$$

Replacing single sided fluorescent fixture in a heat pump heated hospital:

$$\begin{aligned} \Delta\text{kWh}_{\text{heatpenalty}} &= ((7 - 2)/1000) * 8766 * -0.104 \\ &= -4.6 \text{ kWh} \end{aligned}$$

### SUMMER COINCIDENT PEAK DEMAND SAVINGS

$$\Delta\text{kW} = ((\text{WattsBase} - \text{WattsEE}) / 1000) * \text{WHF}_d * \text{CF}$$

<sup>1267</sup> Average CFL single sided (5W, 7W, 9W) from Appendix B 2013-14 Table of Standard Fixture Wattages.

<sup>1268</sup> Average LED single sided (2W) from Appendix B 2013-14 Table of Standard Fixture Wattages.

<sup>1269</sup> Negative value because this is an increase in heating consumption due to the efficient lighting.

Where:

WHF<sub>d</sub> = Waste heat factor for demand to account for cooling savings from efficient lighting in cooled buildings is provided in the Reference Table in Section 4.5. If unknown, use the Miscellaneous value.

CF = Summer Peak Coincidence Factor for measure  
= 1.0

**For example**, replacing incandescent fixture in an office:  

$$\Delta kW = ((35 - 2)/1000) * 1.3 * 1.0$$

$$= 0.043 \text{ kW}$$
 Replacing single sided fluorescent fixture in a hospital:  

$$\Delta kW = ((7 - 2)/1000) * 1.69 * 1.0$$

$$= 0.0085 \text{ kW}$$

**FOSSIL FUEL SAVINGS**

Heating Penalty if natural gas heated building (or if heating fuel is unknown):

$$\Delta \text{therms} = ((\text{WattsBase} - \text{WattsEE})/1000) * \text{Hours} * \text{IFTherms}$$

Where:

IFTherms = Lighting-HVAC Integration Factor for gas heating impacts; this factor represents the increased gas space heating requirements due to the reduction of waste heat rejected by the efficient lighting. Values are provided in the Reference Table in Section 4.5. If unknown, use the Miscellaneous value.

**For example**, replacing incandescent fixture in an office:  

$$\Delta \text{Therms} = ((35 - 2)/1000) * 8766 * -0.016$$

$$= -4.63 \text{ Therms}$$
 Replacing single sided fluorescent fixture in a hospital:  

$$\Delta \text{Therms} = ((7 - 2)/1000) * 8766 * -0.011$$

$$= -0.48 \text{ Therms}$$

**WATER IMPACT DESCRIPTIONS AND CALCULATION**

N/A

**DEEMED O&M COST ADJUSTMENT CALCULATION**

The annual O&M Cost Adjustment savings should be calculated using the following component costs and lifetimes.

Component	Baseline Measures	
	Cost	Life (yrs)
Lamp	\$12.45 <sup>1270</sup>	1.37 years <sup>1271</sup>

<sup>1270</sup> Consistent with assumption for a Standard CFL bulb (\$2.45) with an estimated labor cost of \$10 (assuming \$40/hour and a task time of 15 minutes).

<sup>1271</sup> Assumes a lamp life of 12,000 hours and 8766 run hours 12000/8766 = 1.37 years.



**MEASURE CODE: CI-LTG-LEDE-V04-240101**

**REVIEW DEADLINE: 1/1/2028**

## 4.5.6 LED Traffic and Pedestrian Signals

### DESCRIPTION

Traffic and pedestrian signals are retrofitted to be illuminated with light emitting diodes (LED) instead of incandescent lamps. Incentive applies for the replacement or retrofit of existing incandescent traffic signals with new LED traffic and pedestrian signal lamps. Each lamp can have no more than a maximum LED module wattage of 25. Incentives are not available for spare lights. Lights must be hardwired and single lamp replacements are not eligible, with the exception of pedestrian hand signals. Eligible lamps must meet the Energy Star Traffic Signal Specification and the Institute for Transportation Engineers specification for traffic signals.

This measure was developed to be applicable to the following program types: RF.

If applied to other program types, the measure savings should be verified.

### DEFINITION OF EFFICIENT EQUIPMENT

Refer to the Table titled ‘Traffic Signals Technology Equivalencies’ for efficient technology wattage and savings assumptions.

### DEFINITION OF BASELINE EQUIPMENT

Refer to the Table titled ‘Traffic Signals Technology Equivalencies’ for baseline efficiencies and savings assumptions.

### DEEMED LIFETIME OF EFFICIENT EQUIPMENT

The assumed lifetime of an LED traffic signal is 10 years. The life in years is calculated by dividing 100,000 hrs (manufacturer’s estimate) by the annual operating hours for the particular signal type and is capped at 10 years.<sup>1272</sup>.

### DEEMED MEASURE COST

The actual measure installation cost should be used (including material and labor).

### LOADSHAPE

Loadshape C24 - Traffic Signal - Red Balls, always changing or flashing

Loadshape C25 - Traffic Signal - Red Balls, changing day, off night

Loadshape C26 - Traffic Signal - Green Balls, always changing

Loadshape C27 - Traffic Signal - Green Balls, changing day, off night

Loadshape C28 - Traffic Signal - Red Arrows

Loadshape C29 - Traffic Signal - Green Arrows

Loadshape C30 - Traffic Signal - Flashing Yellows

Loadshape C31 - Traffic Signal - “Hand” Don’t Walk Signal

Loadshape C32 - Traffic Signal - “Man” Walk Signal

Loadshape C33 - Traffic Signal - Bi-Modal Walk/Don’t Walk

### COINCIDENCE FACTOR<sup>1273</sup>

The summer peak coincidence factor (CF) for this measure is dependent on lamp type as below:

Lamp Type	CF
Red Round, always changing or flashing	0.55
Red Arrows	0.90

<sup>1272</sup> ACEEE, (1998) A Market Transformation Opportunity Assessment for LED Traffic Signals

<sup>1273</sup> Ibid.

Lamp Type	CF
Green Arrows	0.10
Yellow Arrows	0.03
Green Round, always changing or flashing	0.43
Flashing Yellow	0.50
Yellow Round, always changing	0.02
“Hand” Don’t Walk Signal	0.75
“Man” Walk Signal	0.21

---

**Algorithm**

---

**CALCULATION OF SAVINGS**

**ELECTRIC ENERGY SAVINGS**

$$\Delta kWh = (W_{base} - W_{eff}) \times HOURS / 1000$$

Where:

- Wbase = The connected load of the baseline equipment  
= see Table ‘Traffic Signals Technology Equivalencies’
- Weff = The connected load of the baseline equipment  
= see Table ‘Traffic Signals Technology Equivalencies’
- HOURS = annual operating hours of the lamp  
= see Table ‘Traffic Signals Technology Equivalencies’
- 1000 = conversion factor (W/kW)

**For example**, an 8 inch red, round signal:

$$\begin{aligned} \Delta kWh &= ((69 - 7) \times 4818) / 1000 \\ &= 299 \text{ kWh} \end{aligned}$$

**SUMMER COINCIDENT PEAK DEMAND SAVINGS**

$$\Delta kW = (W_{base} - W_{eff}) \times CF / 1000$$

Where:

- Wbase = The connected load of the baseline equipment  
= see Table ‘Traffic Signals Technology Equivalencies’
- Weff = The connected load of the efficient equipment  
= see Table ‘Traffic Signals Technology Equivalencies’
- CF = Summer Peak Coincidence Factor for measure

**For example**, an 8 inch red, round signal:

$$\begin{aligned} \Delta kW &= ((69 - 7) \times 0.55) / 1000 \\ &= 0.0341 \text{ kW} \end{aligned}$$

**FOSSIL FUEL SAVINGS**

N/A

**WATER IMPACT DESCRIPTIONS AND CALCULATION**

N/A

**REFERENCE TABLES**

Traffic Signals Technology Equivalencies<sup>1274</sup>

Traffic Fixture Type	Fixture Size and Color	Efficient Lamps	Baseline Lamps	HOURS	Efficient Fixture Wattage	Baseline Fixture Wattage	Energy Savings (in kWh)
Round Signals	8" Red	LED	Incandescent	4818	7	69	299
Round Signals	12" Red	LED	Incandescent	4818	6	150	694
Flashing Signal <sup>1275</sup>	8" Red	LED	Incandescent	4380	7	69	272
Flashing Signal	12" Red	LED	Incandescent	4380	6	150	631
Flashing Signal	8" Yellow	LED	Incandescent	4380	10	69	258
Flashing Signal	12" Yellow	LED	Incandescent	4380	13	150	600
Round Signals	8" Yellow	LED	Incandescent	175	10	69	10
Round Signals	12" Yellow	LED	Incandescent	175	13	150	24
Round Signals	8" Green	LED	Incandescent	3767	9	69	226
Round Signals	12" Green	LED	Incandescent	3767	12	150	520
Turn Arrows	8" Yellow	LED	Incandescent	701	7	116	76
Turn Arrows	12" Yellow	LED	Incandescent	701	9	116	75
Turn Arrows	8" Green	LED	Incandescent	701	7	116	76
Turn Arrows	12" Green	LED	Incandescent	701	7	116	76
Pedestrian Sign	12" Hand/Man	LED	Incandescent	8766	8	116	947

Reference specifications for above traffic signal wattages are from the following manufacturers:

1. 8" Incandescent traffic signal bulb: General Electric Traffic Signal Model 17325-69A21/TS
2. 12" Incandescent traffic signal bulb: General Electric Signal Model 35327-150PAR46/TS
3. Incandescent Arrows & Hand/Man Pedestrian Signs: General Electric Traffic Signal Model 19010-116A21/TS
4. 8" and 12" LED traffic signals: Leotek Models TSL-ES08 and TSL-ES12
5. 8" LED Yellow Arrow: General Electric Model DR4-YTA2-01A
6. 8" LED Green Arrow: General Electric Model DR4-GCA2-01A
7. 12" LED Yellow Arrow: Dialight Model 431-3334-001X
8. 12: LED Green Arrow: Dialight Model 432-2324-001X
9. LED Hand/Man Pedestrian Sign: Dialight 430-6450-001X

**MEASURE CODE: CI-LTG-LEDT-V04-240101**

**REVIEW DEADLINE: 1/1/2027**

<sup>1274</sup> Technical Reference Manual for Pennsylvania Act 129 Energy Efficiency and Conservation Program and Act 213 Alternative Energy Portfolio Standards. Pennsylvania Public Utility Commission. May 2009.

<sup>1275</sup> Technical Reference Manual for Ohio, August 6, 2010.

## 4.5.7 Lighting Power Density

### DESCRIPTION

This measure relates to installation of efficient lighting systems in new construction or substantial renovation of commercial buildings excluding low rise (three stories or less) residential buildings. Substantial renovation is when two or more building systems are renovated, such as shell and heating, heating and lighting, etc. State Energy Code specifies a lighting power density level by building type for both the interior and the exterior. Either the Building Area Method or Space by Space method as defined in 2015, 2018, or 2021, depending on the IECC in effect on the date of the building permit (if unknown assume IECC 2021), can be used for calculating the Interior Lighting Power Density.<sup>1276</sup> The measure consists of a design that is more efficient (has a lower lighting power density in watts/square foot) than code requires. The IECC applies to both new construction and renovation.

This measure was developed to be applicable to the following program types: NC.

If applied to other program types, the measure savings should be verified.

### DEFINITION OF EFFICIENT EQUIPMENT

In order for this characterization to apply, the lighting system must be more efficient than the baseline Energy Code lighting power density in watts/square foot for either the interior space or exterior space.

### DEFINITION OF BASELINE EQUIPMENT

The baseline is assumed to be a lighting power density that meets the IECC in effect on the date of the building permit (if unknown assume IECC 2021).

Note, IECC 2021 is expected to become effective statewide in 2023. IECC 2018 is the requisite code for any projects with permitting dates spanning July 1, 2019 to the IECC 2021 effective date. Prior to July 1, 2019, IECC 2015 is the applicable code. As code requirements and adoption can differ from municipality to municipality, the user should verify which version of code is applicable given these constraints.

### DEEMED CALCULATION FOR THIS MEASURE

Annual kWh Savings

$$\Delta \text{kWh} = (\text{WSF}_{\text{base}} - \text{WSF}_{\text{effic}}) / 1000 * \text{SF} * \text{Hours} * \text{WHF}_e$$

Summer Coincident Peak kW Savings

$$\Delta \text{kW} = (\text{WSF}_{\text{base}} - \text{WSF}_{\text{effic}}) / 1000 * \text{SF} * \text{CF} * \text{WHF}_d$$

### DEEMED LIFETIME OF EFFICIENT EQUIPMENT

The expected measure life is assumed to be 15 years.<sup>1277</sup>

### DEEMED MEASURE COST

The actual incremental cost over a baseline system will be collected from the customer if possible or developed on a fixture by fixture basis.

### LOADSHAPE

Loadshape C06 - Commercial Indoor Lighting

Loadshape C07 - Grocery/Conv. Store Indoor Lighting

---

<sup>1276</sup> Refer to the referenced code documents for specifics on calculating lighting power density using either the whole building method or the Space by Space method.

<sup>1277</sup> Measure Life Report, Residential and Commercial/Industrial/Industrial Lighting and HVAC Measures, GDS Associates, June 2007.

- Loadshape C08 - Hospital Indoor Lighting
- Loadshape C09 - Office Indoor Lighting
- Loadshape C10 - Restaurant Indoor Lighting
- Loadshape C11 - Retail Indoor Lighting
- Loadshape C12 - Warehouse Indoor Lighting
- Loadshape C13 - K-12 School Indoor Lighting
- Loadshape C14 - Indust. 1-shift (8/5) (e.g., comp. air, lights)
- Loadshape C15 - Indust. 2-shift (16/5) (e.g., comp. air, lights)
- Loadshape C16 - Indust. 3-shift (24/5) (e.g., comp. air, lights)
- Loadshape C17 - Indust. 4-shift (24/7) (e.g., comp. air, lights)
- Loadshape C18 - Industrial Indoor Lighting
- Loadshape C19 - Industrial Outdoor Lighting
- Loadshape C20 - Commercial Outdoor Lighting

**COINCIDENCE FACTOR**

The summer peak coincidence factor for this measure is dependent on the building type.

---



---

**Algorithm**

---

**CALCULATION OF SAVINGS**

**ENERGY SAVINGS**

$$\Delta kWh = (WSF_{base} - WSF_{effic}) / 1000 * SF * Hours * WHF_e$$

Where:

- WSF<sub>base</sub> = Baseline lighting watts per square foot or linear foot as determined by building or space type. Whole building analysis values are presented in the Reference Tables below.<sup>1278</sup>
- WSF<sub>effic</sub> = The actual installed lighting watts per square foot or linear foot.
- SF = Provided by customer based on square footage of the building area applicable to the lighting design for new building.
- Hours = Annual site-specific hours of operation of the lighting equipment collected from the customer. If not available, use building area type as provided in the Reference Table in Section 4.5, Fixture annual operating hours.
- WHF<sub>e</sub> = Waste Heat Factor for Energy to account for cooling savings from efficient lighting is as provided in the Reference Table in Section 4.5 by building type. If building is not cooled WHF<sub>e</sub> is 1.

**HEATING PENALTY**

If electrically heated building:

$$\Delta kWh_{heatpenalty}^{1279} = (WSF_{base} - WSF_{effic}) / 1000 * SF * Hours * -IFkWh$$

Where:

---

<sup>1278</sup>See Reference Code documentation for additional information.

<sup>1279</sup>Negative value because this is an increase in heating consumption due to the efficient lighting.

IFkWh = Lighting-HVAC Interaction Factor for electric heating impacts; this factor represents the increased electric space heating requirements due to the reduction of waste heat rejected by the efficient lighting. Values are provided in the Reference Table in Section 4.5. If unknown, use the Miscellaneous value.

**SUMMER COINCIDENT PEAK DEMAND SAVINGS**

$$\Delta kW = (WSF_{base} - WSF_{effic}) / 1000 * SF * CF * WHF_d$$

Where:

WHF<sub>d</sub> = Waste Heat Factor for Demand to account for cooling savings from efficient lighting in cooled buildings is as provided in the Reference Table in Section 4.5 by building type. If building is not cooled WHF<sub>d</sub> is 1.

CF = Summer Peak Coincidence Factor for measure is as provided in the Reference Table in Section 4.5 by building type. If the building type is unknown, use the Miscellaneous value of 0.66.

Other factors as defined above

**FOSSIL FUEL SAVINGS**

$$\Delta \text{Therms} = (WSF_{base} - WSF_{effic}) / 1000 * SF * \text{Hours} * - \text{IFTtherms}$$

Where:

IFTtherms = Lighting-HVAC Integration Factor for gas heating impacts; this factor represents the increased gas space heating requirements due to the reduction of waste heat rejected by the efficient lighting. This value is provided in the Reference Table in Section 4.5 by building type.

**WATER IMPACT DESCRIPTIONS AND CALCULATION**

N/A

**DEEMED O&M COST ADJUSTMENT CALCULATION**

N/A

**REFERENCE TABLES**

Lighting Power Density Values from 2015, 2018, and 2021 for Interior Commercial New Construction and Substantial Renovation Building Area Method:

Building Area Type <sup>1280</sup>	IECC 2015 Lighting Power Density (w/ft <sup>2</sup> )	IECC 2018 Lighting Power Density (w/ft <sup>2</sup> )	IECC 2021 Lighting Power Density (w/ft <sup>2</sup> )
Automotive Facility	0.80	0.71	0.75
Convention Center	1.01	0.76	0.64
Court House	1.01	0.9	0.79
Dining: Bar Lounge/Leisure	1.01	0.9	0.80
Dining: Cafeteria/Fast Food	0.9	0.79	0.76
Dining: Family	0.95	0.78	0.71
Dormitory	0.57	0.61	0.53
Exercise Center	0.84	0.65	0.72

<sup>1280</sup> In cases where both a general building area type and a more specific building area type are listed, the more specific building area type shall apply.

Building Area Type <sup>1280</sup>	IECC 2015 Lighting Power Density (w/ft <sup>2</sup> )	IECC 2018 Lighting Power Density (w/ft <sup>2</sup> )	IECC 2021 Lighting Power Density (w/ft <sup>2</sup> )
Fire station	0.67	0.53	0.56
Gymnasium	0.94	0.68	0.76
Healthcare – clinic	0.90	0.82	0.81
Hospital	1.05	1.05	0.96
Hotel	0.87	0.75	0.56
Library	1.19	0.78	0.83
Manufacturing Facility	1.17	0.90	0.82
Motel	0.87	0.75	0.56
Motion Picture Theater	0.76	0.83	0.44
Multifamily	0.51	0.68	0.45
Museum	1.02	1.06	0.55
Office	0.82	0.79	0.64
Parking Garage	0.21	0.15	0.18
Penitentiary	0.81	0.75	0.69
Performing Arts Theater	1.39	1.18	0.84
Police Station	0.87	0.80	0.66
Post Office	0.87	0.67	0.65
Religious Building	1.0	0.94	0.67
Retail <sup>1281</sup>	1.26	1.06	0.84
School/University	0.87	0.81	0.72
Sports Arena	0.91	0.87	0.76
Town Hall	0.89	0.80	0.69
Transportation	0.70	0.61	0.50
Warehouse	0.66	0.48	0.45
Workshop	1.19	0.90	0.91

<sup>1281</sup> Where lighting equipment is specified to be installed to highlight specific merchandise in addition to lighting equipment specified for general lighting and is switched or dimmed on circuits different from the circuits for general lighting, the small of the actual wattage of the lighting equipment installed specifically for merchandise, or additional lighting power as determined below shall be added to the interior lighting power determined in accordance with this line item.



Lighting Power Density Values from IECC 2015 for Interior Commercial New Construction and Substantial Renovation Space by Space Method:

**TABLE C405.4.2(2)  
INTERIOR LIGHTING POWER ALLOWANCES:  
SPACE-BY-SPACE METHOD**

COMMON SPACE TYPES <sup>a</sup>	LPD (watts/sq.ft)
<b>Atrium</b>	
Less than 40 feet in height	0.03 per foot in total height
Greater than 40 feet in height	0.40 + 0.02 per foot in total height
<b>Audience seating area</b>	
In an auditorium	0.63
In a convention center	0.82
In a gymnasium	0.65
In a motion picture theater	1.14
In a penitentiary	0.28
In a performing arts theater	2.43
In a religious building	1.53
In a sports arena	0.43
Otherwise	0.43
Banking activity area	1.01
<b>Breakroom (See Lounge/Breakroom)</b>	
<b>Classroom/lecture hall/training room</b>	
In a penitentiary	1.34
Otherwise	1.24
Conference/meeting/multipurpose room	1.23
Copy/print room	0.72
<b>Corridor</b>	
In a facility for the visually impaired (and not used primarily by the staff) <sup>b</sup>	0.92
In a hospital	0.79
In a manufacturing facility	0.41
Otherwise	0.66
Courtroom	1.72
Computer room	1.71
<b>Dining area</b>	
In a penitentiary	0.96
In a facility for the visually impaired (and not used primarily by the staff) <sup>b</sup>	1.9
In bar/lounge or leisure dining	1.07
In cafeteria or fast food dining	0.65
In family dining	0.89
Otherwise	0.65
Electrical/mechanical room	0.95
Emergency vehicle garage	0.56

(continued)

**TABLE C405.4.2(2)—continued  
INTERIOR LIGHTING POWER ALLOWANCES:  
SPACE-BY-SPACE METHOD**

COMMON SPACE TYPES <sup>a</sup>	LPD (watts/sq.ft)
Food preparation area	1.21
Guest room	0.47
<b>Laboratory</b>	
In or as a classroom	1.43
Otherwise	1.81
Laundry/washing area	0.6
Loading dock, interior	0.47
<b>Lobby</b>	
In a facility for the visually impaired (and not used primarily by the staff) <sup>b</sup>	1.8
For an elevator	0.64
In a hotel	1.06
In a motion picture theater	0.59
In a performing arts theater	2.0
Otherwise	0.9
Locker room	0.75
<b>Lounge/breakroom</b>	
In a healthcare facility	0.92
Otherwise	0.73
<b>Office</b>	
Enclosed	1.11
Open plan	0.98
Parking area, interior	0.19
Pharmacy area	1.68
<b>Restroom</b>	
In a facility for the visually impaired (and not used primarily by the staff) <sup>b</sup>	1.21
Otherwise	0.98
Sales area	1.59
Seating area, general	0.54
<b>Stairway (See space containing stairway)</b>	
Stairwell	0.69
Storage room	0.63
Vehicular maintenance area	0.67
Workshop	1.59
BUILDING TYPE SPECIFIC SPACE TYPES <sup>a</sup>	LPD (watts/sq.ft)
<b>Facility for the visually impaired<sup>b</sup></b>	
In a chapel (and not used primarily by the staff)	2.21
In a recreation room (and not used primarily by the staff)	2.41
<b>Automotive (See Vehicular Maintenance Area above)</b>	
Convention Center—exhibit space	1.45
Dormitory—living quarters	0.38
Fire Station—sleeping quarters	0.22
<b>Gymnasium/fitness center</b>	
In an exercise area	0.72
In a playing area	1.2

(continued)

**TABLE C405.4.2(2)—continued  
INTERIOR LIGHTING POWER ALLOWANCES:  
SPACE-BY-SPACE METHOD**

BUILDING TYPE SPECIFIC SPACE TYPES <sup>a</sup>	LPD (watts/sq.ft)
<b>healthcare facility</b>	
In an exam/treatment room	1.66
In an imaging room	1.51
In a medical supply room	0.74
In a nursery	0.88
In a nurse's station	0.71
In an operating room	2.48
In a patient room	0.62
In a physical therapy room	0.91
In a recovery room	1.15
<b>Library</b>	
In a reading area	1.06
In the stacks	1.71
<b>Manufacturing facility</b>	
In a detailed manufacturing area	1.29
In an equipment room	0.74
In an extra high bay area (greater than 50' floor-to-ceiling height)	1.05
In a high bay area (25-50' floor-to-ceiling height)	1.23
In a low bay area (less than 25' floor-to-ceiling height)	1.19
<b>Museum</b>	
In a general exhibition area	1.05
In a restoration room	1.02
Performing arts theater—dressing room	0.61
Post Office—Sorting Area	0.94
<b>Religious buildings</b>	
In a fellowship hall	0.64
In a worship/pulpit/choir area	1.53
<b>Retail facilities</b>	
In a dressing/fitting room	0.71
In a mall concourse	1.1
<b>Sports arena—playing area</b>	
For a Class I facility	3.68
For a Class II facility	2.4
For a Class III facility	1.8
For a Class IV facility	1.2
<b>Transportation facility</b>	
In a baggage/carousel area	0.53
In an airport concourse	0.36
At a terminal ticket counter	0.8
<b>Warehouse—storage area</b>	
For medium to bulky, palletized items	0.58
For smaller, hand-carried items	0.95

- a. In cases where both a common space type and a building area specific space type are listed, the building area specific space type shall apply
- b. A 'Facility for the Visually Impaired' is a facility that is licensed or will be licensed by local or state authorities for senior long-term care, adult daycare, senior support or people with special visual needs.

Lighting Power Density Values from IECC 2018 for Interior Commercial New Construction and Substantial Renovation Space by Space Method:

TABLE C405.3.2(2)  
INTERIOR LIGHTING POWER ALLOWANCES: SPACE-BY-SPACE METHOD

COMMON SPACE TYPES <sup>a</sup>	LPD (watts/sq.ft)
Atrium	
Less than 40 feet in height	0.03 per foot in total height
Greater than 40 feet in height	0.40 + 0.02 per foot in total height
Audience seating area	
In an auditorium	0.63
In a convention center	0.82
In a gymnasium	0.65
In a motion picture theater	1.14
In a penitentiary	0.28
In a performing arts theater	2.03
In a religious building	1.53
In a sports arena	0.43
Otherwise	0.43
Banking activity area	
Breakroom (See Lounge/breakroom)	
Classroom/lecture hall/training room	
In a penitentiary	1.34
Otherwise	0.96
Computer room	
Conference/meeting/multipurpose room	
Copy/print room	
Corridor	
In a facility for the visually impaired (and not used primarily by the staff) <sup>b</sup>	0.92
In a hospital	0.92
In a manufacturing facility	0.29
Otherwise	0.66
Courtroom	
Dining area	
In bar/lounge or leisure dining	0.93
In cafeteria or fast food dining	0.63
In a facility for the visually impaired (and not used primarily by the staff) <sup>b</sup>	2.00
In family dining	0.71
In a penitentiary	0.96
Otherwise	0.63
Electrical/mechanical room	
Emergency vehicle garage	
Food preparation area	
Guestroom <sup>c, d</sup>	
Laboratory	
In or as a classroom	1.20
Otherwise	1.45

Laundry/washing area	0.43
Loading dock, interior	0.58
Lobby	
For an elevator	0.68
In a facility for the visually impaired (and not used primarily by the staff) <sup>b</sup>	2.03
In a hotel	1.06
In a motion picture theater	0.45
In a performing arts theater	1.70
Otherwise	1.0
Locker room	0.48
Lounge/breakroom	
In a healthcare facility	0.78
Otherwise	0.62
Office	
Enclosed	0.93
Open plan	0.81
Parking area, interior	0.14
Pharmacy area	1.34
Restroom	
In a facility for the visually impaired (and not used primarily by the staff) <sup>b</sup>	0.96
Otherwise	0.85
Sales area	1.22
Seating area, general	0.42
Stairway (see Space containing stairway)	
Stairwell	0.58
Storage room	0.46
Vehicular maintenance area	0.58
Workshop	1.14

BUILDING TYPE SPECIFIC SPACE TYPES <sup>a</sup>	LPD (watts/sq.ft)
Automotive (see Vehicular maintenance area)	
Convention Center—exhibit space	0.88
Dormitory—living quarters <sup>c, d</sup>	0.54
Facility for the visually impaired <sup>b</sup>	
In a chapel (and not used primarily by the staff)	1.06
In a recreation room (and not used primarily by the staff)	1.80
Fire Station—sleeping quarters <sup>c</sup>	0.20
Gymnasium/fitness center	
In an exercise area	0.50
In a playing area	0.82
Healthcare facility	
In an exam/treatment room	1.68
In an imaging room	1.06
In a medical supply room	0.54
In a nursery	1.00
In a nurse's station	0.81
In an operating room	2.17
In a patient room <sup>c</sup>	0.62
In a physical therapy room	0.84
In a recovery room	1.03
Library	
In a reading area	0.82
In the stacks	1.20
Manufacturing facility	
In a detailed manufacturing area	0.93
In an equipment room	0.65
In an extra-high-bay area (greater than 50' floor-to-ceiling height)	1.05
In a high-bay area (25-50' floor-to-ceiling height)	0.75
In a low-bay area (less than 25' floor-to-ceiling height)	0.96
Museum	
In a general exhibition area	1.05
In a restoration room	0.85
Performing arts theater—dressing room	0.36
Post office—sorting area	0.68
Religious buildings	
In a fellowship hall	0.55
In a worship/pulpit/choir area	1.53

Retail facilities	
In a dressing/fitting room	0.50
In a mall concourse	0.90
Sports arena—playing area	
For a Class I facility <sup>a</sup>	2.47
For a Class II facility <sup>f</sup>	1.98
For a Class III facility <sup>g</sup>	1.70
For a Class IV facility <sup>h</sup>	1.13
Transportation facility	
In a baggage/carousel area	0.45
In an airport concourse	0.31
At a terminal ticket counter	0.82
Warehouse—storage area	
For medium to bulky, palletized items	0.35
For smaller, hand-carried items	0.89

- a. In cases where both a common space type and a building area specific space type are listed, the building area specific space type shall apply.
- b. A 'Facility for the Visually Impaired' is a facility that is licensed or will be licensed by local or state authorities for senior long-term care, adult daycare, senior support or people with special visual needs.
- c. Where sleeping units are excluded from lighting power calculations by application of Section R405.1, neither the area of the sleeping units nor the wattage of lighting in the sleeping units is counted.
- d. Where dwelling units are excluded from lighting power calculations by application of Section R405.1, neither the area of the dwelling units nor the wattage of lighting in the dwelling units is counted.
- e. Class I facilities consist of professional facilities; and semiprofessional, collegiate, or club facilities with seating for 5,000 or more spectators.
- f. Class II facilities consist of collegiate and semiprofessional facilities with seating for fewer than 5,000 spectators; club facilities with seating for between 2,000 and 5,000 spectators; and amateur league and high-school facilities with seating for more than 2,000 spectators.
- g. Class III facilities consist of club, amateur league and high-school facilities with seating for 2,000 or fewer spectators.
- h. Class IV facilities consist of elementary school and recreational facilities; and amateur league and high-school facilities without provision for spectators.

Lighting Power Density Values from IECC 2021 for Interior Commercial New Construction and Substantial Renovation Space by Space Method:

**TABLE C405.3.2(2)  
INTERIOR LIGHTING POWER ALLOWANCES:  
SPACE-BY-SPACE METHOD**

COMMON SPACE TYPES*	LPD (watts/ft <sup>2</sup> )
<b>Atrium</b>	
Less than 40 feet in height	0.48
Greater than 40 feet in height	0.60
<b>Audience seating area</b>	
In an auditorium	0.61
In a gymnasium	0.23
In a motion picture theater	0.27
In a penitentiary	0.67
In a performing arts theater	1.16
In a religious building	0.72
In a sports arena	0.33
Otherwise	0.33
Banking activity area	0.61
<b>Breakroom (See Lounge/breakroom)</b>	
<b>Classroom/lecture hall/training room</b>	
In a penitentiary	0.89
Otherwise	0.71
Computer room, data center	0.94
Conference/meeting/multipurpose room	0.97
Copy/print room	0.31

**TABLE C405.3.2(2)—continued  
INTERIOR LIGHTING POWER ALLOWANCES:  
SPACE-BY-SPACE METHOD**

COMMON SPACE TYPES*	LPD (watts/ft <sup>2</sup> )
Corridor	
In a facility for the visually impaired (and not used primarily by the staff) <sup>b</sup>	0.71
In a hospital	0.71
Otherwise	0.41
Courtroom	1.20
Dining area	
In bar/lounge or leisure dining	0.86
In cafeteria or fast food dining	0.40
In a facility for the visually impaired (and not used primarily by the staff) <sup>b</sup>	1.27
In family dining	0.60
In a penitentiary	0.42
Otherwise	0.43
Electrical/mechanical room	0.43
Emergency vehicle garage	0.52
Food preparation area	1.09
Guestroom <sup>c, d</sup>	0.41
Laboratory	
In or as a classroom	1.11
Otherwise	1.33
Laundry/washing area	0.53
Loading dock, interior	0.88
Lobby	
For an elevator	0.65
In a facility for the visually impaired (and not used primarily by the staff) <sup>b</sup>	1.69
In a hotel	0.51
In a motion picture theater	0.23
In a performing arts theater	1.25
Otherwise	0.84
Locker room	0.52
Lounge/breakroom	
In a healthcare facility	0.42
Otherwise	0.59
Office	
Enclosed	0.74
Open plan	0.61
Parking area, interior	0.15
Pharmacy area	1.66
Restroom	
In a facility for the visually impaired (and not used primarily by the staff) <sup>b</sup>	1.26
Otherwise	0.63
Sales area	1.05

**TABLE C405.3.2(2)—continued  
INTERIOR LIGHTING POWER ALLOWANCES:  
SPACE-BY-SPACE METHOD**

COMMON SPACE TYPES*	LPD (watts/ft <sup>2</sup> )
Seating area, general	0.23
Stairwell	0.49
Storage room	0.38
Vehicular maintenance area	0.60
Workshop	1.26
BUILDING TYPE SPECIFIC SPACE TYPES*	LPD (watts/ft <sup>2</sup> )
Automotive (see Vehicular maintenance area)	
Convention Center—exhibit space	0.61
Dormitory—living quarters <sup>c, d</sup>	0.50
Facility for the visually impaired <sup>b</sup>	
In a chapel (and not used primarily by the staff)	0.70
In a recreation room (and not used primarily by the staff)	1.77
Fire Station—sleeping quarters <sup>c</sup>	0.23
Gymnasium/fitness center	
In an exercise area	0.90
In a playing area	0.85
Healthcare facility	
In an exam/treatment room	1.40
In an imaging room	0.94
In a medical supply room	0.62
In a nursery	0.92
In a nurse's station	1.17
In an operating room	2.26
In a patient room <sup>c</sup>	0.68
In a physical therapy room	0.91
In a recovery room	1.25
Library	
In a reading area	0.96
In the stacks	1.18
Manufacturing facility	
In a detailed manufacturing area	0.80
In an equipment room	0.76
In an extra-high-bay area (greater than 50 feet floor-to-ceiling height)	1.42
In a high-bay area (25–50 feet floor-to-ceiling height)	1.24
In a low-bay area (less than 25 feet floor-to-ceiling height)	0.86
Museum	
In a general exhibition area	0.31
In a restoration room	1.10
Performing arts theater—dressing room	0.41
Post office—sorting area	0.76



**TABLE C405.3.2(2)—continued**  
**INTERIOR LIGHTING POWER ALLOWANCES:**  
**SPACE-BY-SPACE METHOD**

COMMON SPACE TYPES*	LPD (watts/ft <sup>2</sup> )
Religious buildings	
In a fellowship hall	0.54
In a worship/pulpit/choir area	0.85
Retail facilities	
In a dressing/fitting room	0.51
In a mall concourse	0.82
Sports arena—playing area	
For a Class I facility <sup>e</sup>	2.94
For a Class II facility <sup>f</sup>	2.01
For a Class III facility <sup>g</sup>	1.30
For a Class IV facility <sup>h</sup>	0.86
Transportation facility	
At a terminal ticket counter	0.51
In a baggage/carousel area	0.39
In an airport concourse	0.25
Warehouse—storage area	
For medium to bulky, palletized items	0.33
For smaller, hand-carried items	0.69

The exterior lighting design will be based on the building location and the applicable “Lighting Zone” as defined in IECC 2021 Table C405.5.2(1) which follows. This table is identical to IECC 2018 Table C405.4.2(1) and IECC 2021.

**TABLE C405.5.2(1)  
EXTERIOR LIGHTING ZONES**

LIGHTING ZONE	DESCRIPTION
1	Developed areas of national parks, state parks, forest land, and rural areas
2	Areas predominantly consisting of residential zoning, neighborhood business districts, light industrial with limited nighttime use and residential mixed-use areas
3	All other areas not classified as lighting zone 1, 2 or 4
4	High-activity commercial districts in major metropolitan areas as designated by the local land use planning authority

The lighting power density savings will be based on reductions below the allowable design levels as specified in IECC 2015 Table C405.5.2(2) or 2018 Table C405.2.2(2) or IECC 2021 Table C405.52(2).

Allowable Design Levels from IECC 2015

TABLE C405.5.2(2)  
INDIVIDUAL LIGHTING POWER ALLOWANCES FOR BUILDING EXTERIORS

	LIGHTING ZONES				
	Zone 1	Zone 2	Zone 3	Zone 4	
Base Site Allowance (Base allowance is usable in tradable or nontradable surfaces.)	500 W	600 W	750 W	1300 W	
Tradable Surfaces (Lighting power densities for uncovered parking areas, building grounds, building entrances and exits, canopies and overhangs and outdoor sales areas are tradable.)	<b>Uncovered Parking Areas</b>				
	Parking areas and drives	0.04 W/ft <sup>2</sup>	0.06 W/ft <sup>2</sup>	0.10 W/ft <sup>2</sup>	0.13 W/ft <sup>2</sup>
	<b>Building Grounds</b>				
	Walkways less than 10 feet wide	0.7 W/linear foot	0.7 W/linear foot	0.8 W/linear foot	1.0 W/linear foot
	Walkways 10 feet wide or greater, plaza areas special feature areas	0.14 W/ft <sup>2</sup>	0.14 W/ft <sup>2</sup>	0.16 W/ft <sup>2</sup>	0.2 W/ft <sup>2</sup>
	Stairways	0.75 W/ft <sup>2</sup>	1.0 W/ft <sup>2</sup>	1.0 W/ft <sup>2</sup>	1.0 W/ft <sup>2</sup>
	Pedestrian tunnels	0.15 W/ft <sup>2</sup>	0.15 W/ft <sup>2</sup>	0.2 W/ft <sup>2</sup>	0.3 W/ft <sup>2</sup>
	<b>Building Entrances and Exits</b>				
	Main entries	20 W/linear foot of door width	20 W/linear foot of door width	30 W/linear foot of door width	30 W/linear foot of door width
	Other doors	20 W/linear foot of door width	20 W/linear foot of door width	20 W/linear foot of door width	20 W/linear foot of door width
	Entry canopies	0.25 W/ft <sup>2</sup>	0.25 W/ft <sup>2</sup>	0.4 W/ft <sup>2</sup>	0.4 W/ft <sup>2</sup>
	<b>Sales Canopies</b>				
	Free-standing and attached	0.6 W/ft <sup>2</sup>	0.6 W/ft <sup>2</sup>	0.8 W/ft <sup>2</sup>	1.0 W/ft <sup>2</sup>
	<b>Outdoor Sales</b>				
	Open areas (including vehicle sales lots)	0.25 W/ft <sup>2</sup>	0.25 W/ft <sup>2</sup>	0.5 W/ft <sup>2</sup>	0.7 W/ft <sup>2</sup>
Street frontage for vehicle sales lots in addition to "open area" allowance	No allowance	10 W/linear foot	10 W/linear foot	30 W/linear foot	
Nontradable Surfaces (Lighting power density calculations for the following applications can be used only for the specific application and cannot be traded between surfaces or with other exterior lighting. The following allowances are in addition to any allowance otherwise permitted in the "Tradable Surfaces" section of this table.)	Building facades	No allowance	0.075 W/ft <sup>2</sup> of gross above-grade wall area	0.113 W/ft <sup>2</sup> of gross above-grade wall area	0.15 W/ft <sup>2</sup> of gross above-grade wall area
	Automated teller machines (ATM) and night depositories	270 W per location plus 90 W per additional ATM per location	270 W per location plus 90 W per additional ATM per location	270 W per location plus 90 W per additional ATM per location	270 W per location plus 90 W per additional ATM per location
	Entrances and gatehouse inspection stations at guarded facilities	0.75 W/ft <sup>2</sup> of covered and uncovered area	0.75 W/ft <sup>2</sup> of covered and uncovered area	0.75 W/ft <sup>2</sup> of covered and uncovered area	0.75 W/ft <sup>2</sup> of covered and uncovered area
	Loading areas for law enforcement, fire, ambulance and other emergency service vehicles	0.5 W/ft <sup>2</sup> of covered and uncovered area	0.5 W/ft <sup>2</sup> of covered and uncovered area	0.5 W/ft <sup>2</sup> of covered and uncovered area	0.5 W/ft <sup>2</sup> of covered and uncovered area
	Drive-up windows/doors	400 W per drive-through	400 W per drive-through	400 W per drive-through	400 W per drive-through
	Parking near 24-hour retail entrances	800 W per main entry	800 W per main entry	800 W per main entry	800 W per main entry

For SI: 1 foot = 304.8 mm, 1 watt per square foot = W/0.0929 m<sup>2</sup>.  
W = watts.

Allowable Design Levels from IECC 2018

Table C405.2.2(2)  
Lighting Power Allowances for Building Exteriors

	Zone 0	Zone 1	Zone 2	Zone 3	Zone 4
<b>Base Site Allowance</b> (Base allowance may be used in tradable or nontradable surfaces.)					
	No allowance	350 W	400 W	500 W	900 W
<b>Tradable Surfaces</b> (LPD allowances for uncovered parking areas, building grounds, building entrances, exits and loading docks, canopies and overhangs, and outdoor sales areas may be traded.)					
<b>Uncovered Parking Areas</b>					
Parking areas and drives	No allowance	0.03 W/ft <sup>2</sup>	0.04 W/ft <sup>2</sup>	0.06 W/ft <sup>2</sup>	0.08 W/ft <sup>2</sup>
<b>Building Grounds</b>					
Walkways/ramps less than 10 ft wide	No allowance	0.5 W/linear foot	0.5 W/linear foot	0.6 W/linear foot	0.7 W/linear foot
Walkways/ramps 10 ft wide or greater Plaza areas Special feature areas	No allowance	0.10 W/ft <sup>2</sup>	0.10 W/ft <sup>2</sup>	0.11 W/ft <sup>2</sup>	0.14 W/ft <sup>2</sup>
Dining areas	No allowance	0.65 W/ft <sup>2</sup>	0.65 W/ft <sup>2</sup>	0.75 W/ft <sup>2</sup>	0.95 W/ft <sup>2</sup>
Stairways	No allowance	0.6 W/ft <sup>2</sup>	0.7 W/ft <sup>2</sup>	0.7 W/ft <sup>2</sup>	0.7 W/ft <sup>2</sup>
Pedestrian tunnels	No allowance	0.12 W/ft <sup>2</sup>	0.12 W/ft <sup>2</sup>	0.14 W/ft <sup>2</sup>	0.21 W/ft <sup>2</sup>
Landscaping	No allowance	0.03 W/ft <sup>2</sup>	0.04 W/ft <sup>2</sup>	0.04 W/ft <sup>2</sup>	0.04 W/ft <sup>2</sup>
<b>Building Entrances, Exits, and Loading Docks</b>					
Pedestrian and vehicular entrances and exits	No allowance	14 W/lin ft of opening	14 W/lin ft of opening	21 W/lin ft of opening	21 W/lin ft of opening
Entry canopies	No allowance	0.20 W/ft <sup>2</sup>	0.25 W/ft <sup>2</sup>	0.4 W/ft <sup>2</sup>	0.4 W/ft <sup>2</sup>
Loading docks	No allowance	0.35 W/ft <sup>2</sup>	0.35 W/ft <sup>2</sup>	0.35 W/ft <sup>2</sup>	0.35 W/ft <sup>2</sup>
<b>Sales Canopies</b>					
Free standing and attached	No allowance	0.4 W/ft <sup>2</sup>	0.4 W/ft <sup>2</sup>	0.6 W/ft <sup>2</sup>	0.7 W/ft <sup>2</sup>
<b>Outdoor Sales</b>					
Open areas (including vehicle sales lots)	No allowance	0.2 W/ft <sup>2</sup>	0.2 W/ft <sup>2</sup>	0.35 W/ft <sup>2</sup>	0.5 W/ft <sup>2</sup>
Street frontage for vehicle sales lots in addition to "open area" allowance	No allowance	No allowance	7 W/linear foot	7 W/linear foot	21 W/linear foot

TABLE C405.4.2(3)  
INDIVIDUAL LIGHTING POWER ALLOWANCES FOR BUILDING EXTERIORS

LIGHTING ZONES				
	Zone 1	Zone 2	Zone 3	Zone 4
Building facades	No allowance	0.075 W/ft <sup>2</sup> of gross above-grade wall area	0.113 W/ft <sup>2</sup> of gross above-grade wall area	0.15 W/ft <sup>2</sup> of gross above-grade wall area
Automated teller machines (ATM) and night depositories	135 W per location plus 45 W per additional ATM per location			
Uncovered entrances and gatehouse inspection stations at guarded facilities	0.5 W/ft <sup>2</sup> of area			
Uncovered loading areas for law enforcement, fire, ambulance and other emergency service vehicles	0.35 W/ft <sup>2</sup> of area			
Drive-up windows and doors	200 W per drive through			
Parking near 24-hour retail entrances.	400 W per main entry			

For SI: For SI: 1 watt per square foot = W/0.0929 m<sup>2</sup>.

W = watts.

Allowable Design Levels from IECC 2021

TABLE C405.5.2(2)  
LIGHTING POWER ALLOWANCES FOR BUILDING EXTERIORS

	LIGHTING ZONES			
	Zone 1	Zone 2	Zone 3	Zone 4
Base Site Allowance	350 W	400 W	500 W	900 W
<b>Uncovered Parking Areas</b>				
Parking areas and drives	0.03 W/ft <sup>2</sup>	0.04 W/ft <sup>2</sup>	0.06 W/ft <sup>2</sup>	0.08 W/ft <sup>2</sup>
<b>Building Grounds</b>				
Walkways and ramps less than 10 feet wide	0.50 W/linear foot	0.50 W/linear foot	0.60 W/linear foot	0.70 W/linear foot
Walkways and ramps 10 feet wide or greater, plaza areas, special feature areas	0.10 W/ft <sup>2</sup>	0.10 W/ft <sup>2</sup>	0.11 W/ft <sup>2</sup>	0.14 W/ft <sup>2</sup>
Dining areas	0.65 W/ft <sup>2</sup>	0.65 W/ft <sup>2</sup>	0.75 W/ft <sup>2</sup>	0.95 W/ft <sup>2</sup>
Stairways	0.60 W/ft <sup>2</sup>	0.70 W/ft <sup>2</sup>	0.70 W/ft <sup>2</sup>	0.70 W/ft <sup>2</sup>
Pedestrian tunnels	0.12 W/ft <sup>2</sup>	0.12 W/ft <sup>2</sup>	0.14 W/ft <sup>2</sup>	0.21 W/ft <sup>2</sup>
Landscaping	0.03 W/ft <sup>2</sup>	0.04 W/ft <sup>2</sup>	0.04 W/ft <sup>2</sup>	0.04 W/ft <sup>2</sup>
<b>Building Entrances and Exits</b>				
Pedestrian and vehicular entrances and exits	14 W/linear foot of opening	14 W/linear foot of opening	21 W/linear foot of opening	21 W/linear foot of opening
Entry canopies	0.20 W/ft <sup>2</sup>	0.25 W/ft <sup>2</sup>	0.40 W/ft <sup>2</sup>	0.40 W/ft <sup>2</sup>
Loading docks	0.35 W/ft <sup>2</sup>	0.35 W/ft <sup>2</sup>	0.35 W/ft <sup>2</sup>	0.35 W/ft <sup>2</sup>
<b>Sales Canopies</b>				
Free-standing and attached	0.40 W/ft <sup>2</sup>	0.40 W/ft <sup>2</sup>	0.60 W/ft <sup>2</sup>	0.70 W/ft <sup>2</sup>
<b>Outdoor Sales</b>				
Open areas (including vehicle sales lots)	0.20 W/ft <sup>2</sup>	0.20 W/ft <sup>2</sup>	0.35 W/ft <sup>2</sup>	0.50 W/ft <sup>2</sup>
Street frontage for vehicle sales lots in addition to "open area" allowance	No allowance	7 W/linear foot	7 W/linear foot	21 W/linear foot

For SI: 1 foot = 304.8 mm, 1 watt per square foot = W/0.0929 m<sup>2</sup>.  
W = watts.

TABLE C405.5.2(3)  
INDIVIDUAL LIGHTING POWER ALLOWANCES FOR BUILDING EXTERIORS

	LIGHTING ZONES			
	Zone 1	Zone 2	Zone 3	Zone 4
Building facades	No allowance	0.075 W/ft <sup>2</sup> of gross above-grade wall area	0.113 W/ft <sup>2</sup> of gross above-grade wall area	0.15 W/ft <sup>2</sup> of gross above-grade wall area
Automated teller machines (ATM) and night depositories	135 W per location plus 45 W per additional ATM per location			
Uncovered entrances and gate-house inspection stations at guarded facilities	0.50 W/ft <sup>2</sup> of area			
Uncovered loading areas for law enforcement, fire, ambulance and other emergency service vehicles	0.35 W/ft <sup>2</sup> of area			
Drive-up windows and doors	200 W per drive through			
Parking near 24-hour retail entrances.	400 W per main entry			

For SI: For SI: 1 watt per square foot = W/0.0929 m<sup>2</sup>.  
W = watts.

MEASURE CODE: CI-LTG-LPDE-V09-240101

REVIEW DEADLINE: 1/1/2024

## 4.5.8 Miscellaneous Commercial/Industrial Lighting

### DESCRIPTION

This measure is designed to calculate savings from energy efficient lighting upgrades that are not captured in other measures within the TRM. If a lighting project fits the measure description in other lighting measures, then those criteria, definitions, and calculations should be used.

Unlike other lighting measures this one applies only to RF applications (because there is no defined baseline for TOS or NC applications).

### DEFINITION OF EFFICIENT EQUIPMENT

A lighting fixture that replaces an existing fixture to provide the same or greater lumen output at a lower kW consumption.

### DEFINITION OF BASELINE EQUIPMENT

The definition of baseline equipment is the existing lighting fixture.

### DEEMED LIFETIME OF EFFICIENT EQUIPMENT

The lifetime of the efficient equipment fixture is the rated fixture life divided by hours of use. If unknown the default lifetime for interior fixtures, regardless of program type is 15 years.<sup>1282</sup>

For exterior fixtures, the lifetime is assumed to be 16 years for Dusk-to-Dawn (4303 hours) applications, or 25 years for Dusk-to-Business-Close Year Round (1609 hours) and Dusk-to-Business-Close Seasonal (<1000 hours).<sup>1283</sup>

### DEEMED MEASURE COST

The actual cost of the efficient light fixture should be used.

### LOADSHAPE

- Loadshape C06 - Commercial Indoor Lighting
- Loadshape C07 - Grocery/Conv. Store Indoor Lighting
- Loadshape C08 - Hospital Indoor Lighting
- Loadshape C09 - Office Indoor Lighting
- Loadshape C10 - Restaurant Indoor Lighting
- Loadshape C11 - Retail Indoor Lighting
- Loadshape C12 - Warehouse Indoor Lighting
- Loadshape C13 - K-12 School Indoor Lighting
- Loadshape C14 - Indust. 1-shift (8/5) (e.g., comp. air, lights)
- Loadshape C15 - Indust. 2-shift (16/5) (e.g., comp. air, lights)
- Loadshape C16 - Indust. 3-shift (24/5) (e.g., comp. air, lights)
- Loadshape C17 - Indust. 4-shift (24/7) (e.g., comp. air, lights)
- Loadshape C18 - Industrial Indoor Lighting
- Loadshape C19 - Industrial Outdoor Lighting
- Loadshape C20 - Commercial Outdoor Lighting

---

<sup>1282</sup> 15 years is used based on assumption that most product using this measure will be LED.

<sup>1283</sup> Exterior fixture measure lives are based upon review of the typical rated life of the fixtures, divided by the hours of use assumption and applying a derating factor of 15% to account for potential impacts from external installation (as proposed in a Guidehouse EUL methodology recommendation for Street Lights).

**COINCIDENCE FACTOR**

The summer peak coincidence factor for this measure is dependent on the location type. Values are provided for each building type in section 4.5.

**Algorithm**

**CALCULATION OF SAVINGS**

**ELECTRIC ENERGY SAVINGS**

$$\Delta kWh = ((Watts_{base} - Watts_{EE}) / 1000) * Hours * WHF_e * ISR$$

Where:

**Watts<sub>base</sub>** = Input wattage of the existing system which depends on the baseline fixture configuration (number and type of lamp) and ballast factor (if applicable) and number of fixtures.

= Actual

**Watts<sub>EE</sub>** = New Input wattage of EE fixture which depends on new fixture configuration (number of lamps) and ballast factor (if applicable) (if applicable) and number of fixtures.

= Actual

**Hours** = Average hours of use per year as provided by the customer or selected from the Reference Table in Section 4.5, Fixture annual operating hours, by building type. If hours or building type are unknown, use the Miscellaneous value.

**WHF<sub>e</sub>** = Waste heat factor for energy to account for cooling energy savings from efficient lighting is selected from the Reference Table in Section 4.5 for each building type. If building is un-cooled, the value is 1.0.

**ISR** = In Service Rate or the percentage of units rebated that get installed.

=100% if application form completed with sign off that equipment is not placed into storage.<sup>1284</sup> If sign off form not completed assume the following 3 year ISR assumptions:

Weighted Average 1st year In Service Rate (ISR)	2nd year Installations	3rd year Installations	Final Lifetime In Service Rate
93.4% <sup>1285</sup>	2.5%	2.1%	98.0% <sup>1286</sup>

**HEATING PENALTY**

If electrically heated building:

$$\Delta kWh_{heatpenalty}^{1287} = (((WattsBase - WattsEE) / 1000) * ISR * Hours * -IFkWh$$

Where:

<sup>1284</sup> Illinois evaluation of PY1 through PY3 has not found that fixtures or lamps placed into storage to be a significant enough issue to warrant including an "In-Service Rate" when commercial customers complete an application form.

<sup>1285</sup> Based on assumptions from 4.5.3 High Performance and Reduced Wattage T8 fixtures.

<sup>1286</sup> The 98% Lifetime ISR assumption is based upon review of two evaluations:

'Nexus Market Research, RLW Analytics and GDS Associates study; "New England Residential Lighting Markdown Impact Evaluation, January 20, 2009' and 'KEMA Inc, Feb 2010, Final Evaluation Report:, Upstream Lighting Program, Volume 1.' This implies that only 2% of bulbs purchased are never installed. The second and third year installations are based upon Ameren analysis of the Californian KEMA study showing that 54% of future installs occur in year 2 and 46% in year 3. The 2<sup>nd</sup> and 3<sup>rd</sup> year installations should be counted as part of those future program year savings.

<sup>1287</sup> Negative value because this is an increase in heating consumption due to the efficient lighting.



IFkWh = Lighting-HVAC Interaction Factor for electric heating impacts; this factor represents the increased electric space heating requirements due to the reduction of waste heat rejected by the efficient lighting. Values are provided in the Reference Table in Section 4.5. If unknown, use the Miscellaneous value.

### DEFERRED INSTALLS

As presented above, if a sign off form is not completed the characterization assumes that a percentage of bulbs purchased are not installed until Year 2 and Year 3 (see ISR assumption above). The Illinois Technical Advisory Committee has determined the following methodology for calculating the savings of these future installs.

Year 1 (Purchase Year) installs: Characterized using assumptions provided above or evaluated assumptions if available.

Year 2 and 3 installs: Characterized using delta watts assumption and hours of use from the Install Year, i.e., the actual deemed (or evaluated if available) assumptions active in Year 2 and 3 should be applied.

The NTG factor for the Purchase Year should be applied.

### SUMMER COINCIDENT DEMAND SAVINGS

$$\Delta kW = ((\text{Watts}_{\text{base}} - \text{Watts}_{\text{EE}}) / 1000) * \text{WHF}_d * \text{CF} * \text{ISR}$$

Where:

WHFd = Waste Heat Factor for Demand to account for cooling savings from efficient lighting in cooled buildings is selected from the Reference Table in Section 4.5 for each building type. If the building is not cooled WHFd is 1.

CF = Summer Peak Coincidence Factor for measure is selected from the Reference table in Section 4.5 for each building type. If the building type is unknown, use the Miscellaneous value of 0.66.

Other factors as defined above.

### FOSSIL FUEL SAVINGS

$$\Delta \text{Therms}^{1288} = (((\text{Watts}_{\text{Base}} - \text{Watts}_{\text{EE}}) / 1000) * \text{ISR} * \text{Hours} * - \text{IFTherms}$$

Where:

IFTherms = Lighting-HVAC Integration Factor for gas heating impacts; this factor represents the increased gas space heating requirements due to the reduction of waste heat rejected by the efficient lighting. This value is selected from the Reference Table in Section 6.5 for each building type.

### WATER IMPACT DESCRIPTIONS AND CALCULATION

N/A

### DEEMED O&M COST ADJUSTMENT CALCULATION

If there are differences between the maintenance of the efficient and baseline lighting system then they should be evaluated on a project-by-project basis.

---

<sup>1288</sup>Negative value because this is an increase in heating consumption due to the efficient lighting.

**MEASURE CODE: CI-LTG-MSCI-V05-240101**

**REVIEW DEADLINE: 1/1/2026**

## 4.5.9 Multi-Level Lighting Switch

### DESCRIPTION

This measure relates to the installation new multi-level lighting switches on an existing lighting system.

This measure can only relate to the adding of a new control in an existing building, since multi-level switching is required in the Commercial new construction building energy code (IECC 2012/2015/2018/2021).

This measure was developed to be applicable to the following program types: RF.

If applied to other program types, the measure savings should be verified.

### DEFINITION OF EFFICIENT EQUIPMENT

In order for this characterization to apply, the efficient system is assumed to be a lighting system controlled by multi-level lighting controls.

### DEFINITION OF BASELINE EQUIPMENT

The baseline equipment is assumed to be an uncontrolled lighting system where all lights in a given area are on the same circuit or all circuits come on at the same time.

### DEEMED LIFETIME OF EFFICIENT EQUIPMENT

The expected measure life for all lighting controls is assumed to be 10 years.<sup>1289</sup>

### DEEMED MEASURE COST

When available, the actual cost of the measure shall be used. When not available, the incremental capital cost for this measure is assumed to be \$274.<sup>1290</sup>

### LOADSHAPE

- Loadshape C06 - Commercial Indoor Lighting
- Loadshape C07 - Grocery/Conv. Store Indoor Lighting
- Loadshape C08 - Hospital Indoor Lighting
- Loadshape C09 - Office Indoor Lighting
- Loadshape C10 - Restaurant Indoor Lighting
- Loadshape C11 - Retail Indoor Lighting
- Loadshape C12 - Warehouse Indoor Lighting
- Loadshape C13 - K-12 School Indoor Lighting
- Loadshape C14 - Indust. 1-shift (8/5) (e.g., comp. air, lights)
- Loadshape C15 - Indust. 2-shift (16/5) (e.g., comp. air, lights)
- Loadshape C16 - Indust. 3-shift (24/5) (e.g., comp. air, lights)
- Loadshape C17 - Indust. 4-shift (24/7) (e.g., comp. air, lights)
- Loadshape C18 - Industrial Indoor Lighting
- Loadshape C19 - Industrial Outdoor Lighting
- Loadshape C20 - Commercial Outdoor Lighting

---

<sup>1289</sup> Consistent with Lighting control measure.

<sup>1290</sup> Goldberg et al, State of Wisconsin Public Service Commission of Wisconsin, Focus on Energy Evaluation, Business Programs: Incremental Cost Study, KEMA, October 28, 2009.

**COINCIDENCE FACTOR**

The summer peak coincidence factor for this measure is dependent on the location type. Values are provided for each building type in the reference section below.

**Algorithm**

**CALCULATION OF SAVINGS**

**ELECTRIC ENERGY SAVINGS**

$$\Delta kWh = KW_{Controlled} * Hours * ESF * WHF_e$$

Where:

$KW_{Controlled}$  = Total lighting load connected to the control in kilowatts.  
= Actual

Hours = total operating hours of the controlled lighting circuit before the lighting controls are installed. This number should be collected from the customer. Average hours of use per year are provided in the Reference Table in Section 4.5, Fixture annual operating hours, for each building type if customer specific information is not collected. If unknown building type, use the Miscellaneous value.

ESF = Energy Savings factor (represents the percentage reduction to the  $KW_{controlled}$  due to the use of multi-level switching).  
= Dependent on building type:<sup>1291</sup>

Building Type	Energy Savings Factor (ESF)
Private Office	21.6%
Open Office	16.0%
Retail	14.8%
Classrooms	8.3%
Unknown, average	15%

$WHF_e$  = Waste heat factor for energy to account for cooling energy savings from efficient lighting is provided in the Reference Table in Section 4.5 for each building type. If building is un-cooled, the value is 1.0.

**HEATING PENALTY**

If electrically heated building:

$$\Delta kWh_{heatpenalty}^{1292} = KW_{Controlled} * Hours * ESF * -IFkWh$$

Where:

IFkWh = Lighting-HVAC Interaction Factor for electric heating impacts; this factor represents the increased electric space heating requirements due to the reduction of waste heat rejected by the efficient lighting. Values are provided in the Reference Table in Section 4.5. If unknown, use the Miscellaneous value.

<sup>1291</sup> Based on results from “Lighting Controls Effectiveness Assessment: Final Report on Bi-Level Lighting Study” published by the California Public Utilities Commission (CPUC), prepared by ADM Associates.

<sup>1292</sup>Negative value because this is an increase in heating consumption due to the efficient lighting.

### SUMMER COINCIDENT PEAK DEMAND SAVINGS

$$\Delta kW = KW_{\text{controlled}} * ESF * WHF_d * CF$$

Where:

WHF<sub>d</sub> = Waste Heat Factor for Demand to account for cooling savings from efficient lighting in cooled buildings is provided in the Reference Table in Section 4.5. If the building is un-cooled WHF<sub>d</sub> is 1.

CF = Summer Peak Coincidence Factor for measure is provided in the Reference Table in Section 4.5. If unknown, use the Miscellaneous value of 0.66.<sup>1293</sup>

### FOSSIL FUEL SAVINGS

$$\Delta \text{therms} = KW_{\text{Controlled}} * \text{Hours} * ESF * - \text{IFTherms}$$

Where:

IFTherms = Lighting-HVAC Integration Factor for gas heating impacts; this factor represents the increased gas space heating requirements due to the reduction of waste heat rejected by the efficient lighting and provided in the Reference Table in Section 4.5 by building type.

### WATER IMPACT DESCRIPTIONS AND CALCULATION

N/A

### DEEMED O&M COST ADJUSTMENT CALCULATION

N/A

**MEASURE CODE: CI-LTG-MLLC-V06-230101**

**REVIEW DEADLINE: 1/1/2025**

---

<sup>1293</sup> By applying the ESF and the same coincidence factor for general lighting savings we are in essence assuming that the savings from multi-level switching are as likely during peak periods as any other time. In the absence of better information this seems like a reasonable assumption and if anything may be on the conservative side since you might expect the peak periods to be generally sunnier and therefore more likely to have lower light levels. It is also consistent with the control type reducing the wattage lighting load, the same as the general lighting measures.

## 4.5.10 Lighting Controls

### DESCRIPTION

This measure relates to the installation of new occupancy or daylighting sensors and controls on a new or existing lighting system. Lighting control types covered by this measure include wall, ceiling, fixture mounted or integrated controls in addition to Luminaire Level Lighting Controls (LLLCs) or Networked Lighting Controls (NLC) which have additional high-end trim and networking capabilities. Passive infrared, ultrasonic detectors and fixture-mounted sensors or sensors with a combination thereof are eligible. Lighting controls required by state energy codes are not eligible. This must be a new installation with additional control features and may not solely be a replacement of an existing lighting control with the same control features.

This measure was developed to be applicable to the following program types: RF.

If applied to other program types, the measure savings should be verified.

### DEFINITION OF EFFICIENT EQUIPMENT

Lighting that is controlled by any of the control strategies characterized in this measure; occupancy, daylighting or dual (occupancy and daylighting) controls with or without high-end trim, and Luminaire-level lighting controls (LLLCs) / Networked Lighting Controls (NLC).

LLLCs or NLCs are defined according to DesignLights Consortium (DLC) Networked Lighting Controls definition, which requires systems to have fixture networking capabilities, individual addressability, occupancy sensing, daylight harvesting, high-end trim, flexible zoning, continuous dimming, scheduling and cybersecurity. The network ability allows building managers to group lights with specific zonal control and scheduling strategies, energy monitoring and high-end trim resulting in a higher savings capability. While DLC listing is not a requirement for any control type characterized in this measure, programs should consider eligibility requirements including requiring at least the capability for network controlled occupancy, daylight harvesting and high-end trim to ensure quality product is installed achieving forecasted savings consistent with the measure assumptions below.

A subset of occupancy sensors are those that are programmed as “vacancy” sensors. To qualify as a vacancy sensor, the control must be configured such that manual input is required to turn on the controlled lighting and the control automatically turns the lighting off. Additional savings are achieved compared to standard occupancy sensors because lighting does not automatically turn on and occupants may decide to not turn it on. Note that vacancy sensors are not a viable option for many applications where standard occupancy sensors should be used instead.

### DEFINITION OF BASELINE EQUIPMENT

The baseline is assumed to be the existing lighting system and can include manual or no controls or an existing control strategy that is being improved. Note where an existing inefficient fixture is replaced with an efficient fixture with control, use the fixture measure to calculate savings from the wattage reduction first, then assume the efficient fixture without control as the baseline for the control measure.

### DEEMED LIFETIME OF EFFICIENT EQUIPMENT

The expected measure life for Luminaire-level lighting controls (LLLCs) / Networked Lighting Controls (NLC) is assumed to be 15 years, consistent with the average expected lifetime of the fixture. For all other lighting controls, measure life is assumed to be 10 years.<sup>1294</sup>

### DEEMED MEASURE COST

When available, the actual cost of the measure shall be used. When not available, the following default values are provided:

---

<sup>1294</sup> Based on research conducted by Guidehouse, interviewing 46 contractors, reported in ‘ComEd Retrofit Add-On EUL Results Memo. January 27, 2020.

Lighting Control Type	Incremental Cost <sup>1295</sup>
Interior Wall Switch Occupancy Sensor	\$55.00
Interior Fixture-Mounted Occupancy Sensor	\$67.00
Interior Remote or Wall-Mounted Occupancy Sensor	\$125.00
Interior Fixture-Mounted Daylight Sensor	\$50.00
Interior Remote or Wall-Mounted Daylight Sensor	\$65.00
Interior Integrated Occupancy for LED Interior Fixtures < 10,000 Lumens	\$40.00
Interior Integrated Occupancy for LED Interior Fixtures >= 10,000 Lumens	\$40.00
Interior Integrated Dual Occupancy & Daylight Sensor for LED Interior Fixtures < 10,000 Lumens	\$50.00
Interior Integrated Dual Occupancy & Daylight Sensor for LED Interior Fixtures >= 10,000 Lumens	\$50.00
Interior Fixture-Mounted Dual Occupancy & Daylight Sensor for LED Interior Fixtures < 10,000 Lumens	\$ 100.00
Interior Fixture-Mounted Dual Occupancy & Daylight Sensor for LED Interior Fixtures >= 10,000 Lumens	\$ 100.00
Luminaire-Level Lighting Controls	\$56.00
Interior Networked Lighting Controls <10,000 sqft building	\$0.86 per ft <sup>2</sup>
Interior Networked Lighting Controls 10,000-100,000 sqft building	\$0.59 per ft <sup>2</sup>
Interior Networked Lighting Controls >100,000 sqft building	\$0.40 per ft <sup>2</sup>
High End Trim or Institutional Tuning	\$0.06 per ft <sup>2</sup>
Exterior Occupancy Sensor	\$82.00
Exterior NLC	Use actual

**LOADSHAPE**

- Loadshape C06 - Commercial Indoor Lighting
- Loadshape C07 - Grocery/Conv. Store Indoor Lighting
- Loadshape C08 - Hospital Indoor Lighting
- Loadshape C09 - Office Indoor Lighting
- Loadshape C10 - Restaurant Indoor Lighting
- Loadshape C11 - Retail Indoor Lighting
- Loadshape C12 - Warehouse Indoor Lighting
- Loadshape C13 - K-12 School Indoor Lighting
- Loadshape C14 - Indust. 1-shift (8/5) (e.g., comp. air, lights)
- Loadshape C15 - Indust. 2-shift (16/5) (e.g., comp. air, lights)
- Loadshape C16 - Indust. 3-shift (24/5) (e.g., comp. air, lights)
- Loadshape C17 - Indust. 4-shift (24/7) (e.g., comp. air, lights)
- Loadshape C18 - Industrial Indoor Lighting

<sup>1295</sup> Based on indicative product cost review as performed for Efficiency Vermont TRM. Cost assumption for Luminaire Level Lighting Controls is based on the average of ‘clever’ and ‘clever-hybrid’ LLC incremental costs, including a per fixture contribution to the necessary gateway, servers and installation labor from Kisch et al, “2020 Luminaire Level Lighting Controls Incremental Cost Study”, Energy Solutions on behalf of NEEA, January 2021. Cost assumptions for Interior Networked Lighting Controls is based on the average of “office”, “warehouse”, and “retail” by building size from Schwartz et al., “The Value Proposition for Cost-Effective, Demand Responsive-Enabling Nonresidential Lighting System Retrofits in California Buildings”, Lawrence Berkeley National Laboratory and Energy Solutions prepared for California Energy Commission, April 2019. This includes both material and labor cost estimates.

Cost for High End Trim / Institutional Tuning is based on estimate provided by SlipStream based on field implementation.

- Loadshape C19 - Industrial Outdoor Lighting
- Loadshape C20 - Commercial Outdoor Lighting

**COINCIDENCE FACTOR**

The summer peak coincidence factor for this measure is dependent on building type and can be found in the Reference Table in Section 4.5.

---



---

**Algorithm**

---

**CALCULATION OF SAVINGS**

**ELECTRIC ENERGY SAVINGS**

$$\Delta kWh = KW_{Controlled} * Hours * (ESF_{EE} - ESF_{Base}) * WHF_e$$

Where:

$KW_{Controlled}$  = Total lighting load connected to the control in kilowatts. The total connected load per control should be collected from the customer or the default values presented below used. Note where an existing inefficient fixture is replaced with an efficient fixture with control, use the fixture measure to calculate savings from the wattage reduction first, then assume the efficient fixture without control as the baseline for the control measure.

Lighting Control Type <sup>1296</sup>	Wattage Unit	Default kW Controlled
Interior Wall Switch Occupancy Sensor	per control	0.084
Interior Fixture-Mounted Occupancy Sensor	per fixture	0.081
Interior Remote or Wall-Mounted Occupancy Sensor	per control	0.338
Interior Fixture-Mounted Daylight Sensor	per fixture	0.095
Interior Wall-Mounted Daylight Sensor	per control	0.239
Interior Integrated Occupancy for LED Interior Fixtures < 10,000 Lumens	per fixture	0.031
Interior Integrated Occupancy for LED Interior Fixtures >= 10,000 Lumens	per fixture	0.118
Interior Integrated Dual Occupancy & Daylight Sensor for LED Interior Fixtures < 10,000 Lumens	per control	0.031
Interior Integrated Dual Occupancy & Daylight Sensor for LED Interior Fixtures >= 10,000 Lumens	per control	0.118
Interior Fixture-Mounted Dual Occupancy & Daylight Sensor for LED Interior Fixtures < 10,000 Lumens	per control	0.031
Interior Fixture-Mounted Dual Occupancy & Daylight Sensor for LED Interior Fixtures >= 10,000 Lumens	per control	0.118
Interior Luminaire-Level Lighting Controls < 10,000 Lumens	per control	0.031

<sup>1296</sup> Estimates of watts controlled are based on Efficiency Vermont data as provided in the 2018 TRM. Future evaluation should determine appropriate assumptions based on Illinois program data. Estimated kilowatts per sqft for interior networked lighting controls is based on the lighting power density (LPD) assumption in the Wisconsin Focus on Energy 2019 Technical Reference Manual and divided by 1000. To determine the total  $KW_{Controlled}$  multiply by the controlled sqft. Either the total  $KW_{Controlled}$  or the total sqft must be reported to estimate savings from interior networked lighting controls.



Lighting Control Type <sup>1296</sup>	Wattage Unit	Default kW Controlled
Interior Luminaire-Level Lighting Controls >= 10,000 Lumens	per control	0.118
Interior Networked Lighting Controls	kilowatts controlled per sqft	0.00061
Refrigerated Case Occupancy Sensor – Freezer and Cooler	per control	0.090
Exterior Occupancy Sensor	per fixture kilowatts controlled per sqft	0.086
Exterior NLC		Use actual

Hours = total operating hours of the controlled lighting circuit before the lighting controls are installed. This number should be collected from the customer if possible. If not possible, assume hours as prescribed below:

Control Type	General Building Type <sup>1297</sup>	Reference Table in Section 4.5 Mapped Building/Space Types	Hours
Networked Lighting Controls and Luminaire-Level Lighting Controls	Education	Childcare/Pre-School, College, Elementary School, High School	4,231
	Manufacturing	Manufacturing Facility	5,365
	Office	Office - High Rise - CAV no econ, Office - High Rise- CAV econ, Office- High Rise- VAV econ, Office- High Rise - FCU, Office- Low Rise, Office - Mid Rise	4,453
	Retail	Convenience Store, Drug Store, Grocery, Retail - Department Store, Retail - Strip Mall	6,936
	Warehouse	Warehouse	5,116
	All Other	All other building/space types in the Reference Table in Section 4.5	Use Fixture Annual Operating Hours in the Reference Table in Section 4.5
All other	All	All	Use Fixture Annual Operating Hours in the Reference Table in Section 4.5

ESF = Energy Savings Factor (represents the percentage reduction to the operating Hours from the non-controlled lighting system) from the new lighting controls installed. Where available and with building owner consent, custom savings from controls may be used via networked trending software. If unavailable or consent not provided, defaults are provided below which assume installation is appropriate to provide the savings described. For dual controls and fixtures with high-end trim this should be reviewed and verified via

<sup>1297</sup> These are the general building types and the inferred baseline operating hours reported in DesignLights Consortium and NEEA, “Energy Savings from Networked Lighting Control (NLC) Systems with and without LLLC” Energy Solutions, September 2020. The inferred operating hours for “Assembly”, “Healthcare”, and “Restaurant” were excluded due to the reported small sample size (n=3, n=2, n=3 respectively). The mapping of the general building types to the building/space types listed in Section 4.5 Reference Table was completed by Guidehouse Inc.

representative spot checks to ensure daylighting capabilities will provide savings and fixture tuning is being performed.<sup>1298</sup>

Lighting Control Type	Energy Savings Factor <sup>1299</sup>
Fixture Measurement of Control savings through Networked Trending (Interior or Exterior)	Custom
Interior Occupancy Sensor (Switch, Wall, Fixture or Remote Mounted or Integrated in Fixture)	24% 37% with High End Trim
Interior Occupancy Sensor configured as "Vacancy Sensor" (Switch, Wall, Fixture or Remote Mounted or Integrated in Fixture)	31% 44% with High End Trim
Interior Daylight Sensor (Wall, Fixture or Remote Mounted)	28% 41% with High End Trim
Interior Dual Occupancy & Daylight Sensor (Integrated or Fixture Mounted)	38% 51% with High End Trim <sup>1300</sup>
Interior Networked Luminaire-Level Lighting Controls	61% <sup>1301</sup>
Interior Networked Lighting Controls Only with No LLLCs	35%
Interior Networked Lighting Controls (unknown or mixed LLLCs)	49%
Refrigerated Case Occupancy Sensor – Freezer and Cooler	27%
Exterior Occupancy Sensor	41%
Exterior NLC	48% <sup>1302</sup>
No Lighting Control	0%

<sup>1298</sup> It is recommended that evaluation is performed to assess the extent to which daylighting and high-end trim benefits are appropriately utilized in the field.

<sup>1299</sup> Interior controls % savings based except where noted on LBNL, Williams et al, "Lighting Controls in Commercial Buildings", 2012, p172. ESF for Vacancy Sensors is based on Papamichael, Konstantions, Bi-Level Switching in Office Spaces, California Lighting Technology Center, February 1,2010. See Figure 8 on page 10 for relevant study results. The study shows a 30% extra savings above a typical occupancy sensor; 24% \* 1.3 = 31%.

ESF for Luminaire Level Lighting Controls, Networked Lighting Controls and the 13% High End Trim adder are based upon the weighted average of results from:

Pacific Northwest National Laboratory, "Evaluation of Advanced Lighting Control Systems in a Working Office Environment", November 2018.

Schuetter et al., "Cree SmartCast Lighting Retrofit Demonstration: LED Fixtures and Controls for Advanced Holistic Lighting Solutions", September 2020 (expected).

DesignLights Consortium and NEEA, "Energy Savings from Networked Lighting Control (NLC) Systems with and without LLLC" Energy Solutions, September 2020.. LLLC ESF used in weighted average is the average of all 98 sites with NLCs w/LLLC. NLC ESF is the average of all 194 buildings. High-end trim adder used for other lighting control types is based on the results for the 96 sites w NLCs w/o LLLC and using the "Other Control Strategies" savings where the baseline had influences from high-end trim removed.

Refrigerated Case occupancy sensors ESF is based on percentage of operating hours spent in low-power operation during vacant periods, found in SDG&E workpaper: WPSDGENRLG0027.

Exterior sensors are based upon data from "Application Assessment of Bi-Level LED Parking Lot Lighting" p6.

<sup>1300</sup> The ESF<sub>EE</sub> for interior dual occupancy & daylight sensor with high-end trim is estimated to be higher than the interior networked lighting control ESF<sub>EE</sub> since this measure requires that the sensors be integrated or fixture mounted which has been documented to lead to higher savings than zone or wall sensors. The NLC measure is not specific to fixture, zone, or wall sensors.

<sup>1301</sup> The ESF<sub>EE</sub> for LLLC is not separated out based on the inclusion of high-end trim since the DesignLights Consortium Technical Requirements Version NLC5 (1/25/21) requires that high-end trim is included for all interior networked lighting controls including LLLC.

<sup>1302</sup> Energy Savings Forecast of SolidState Lighting in General Illumination Application, Table F.4 - Building Exterior, DOE, 2019.

$ESF_{Base}$  = Energy Savings Factor of the lighting controls that existed before the new lighting controls were installed. If prior existence of lighting controls is unknown, assume 0.

$WHF_e$  = Waste heat factor for energy to account for cooling energy savings from efficient lighting is provided in the Reference Table in Section 4.5 for each building type. If building is un-cooled, the value is 1.0.

### HEATING PENALTY

If electrically heated building:

$$\Delta kWh_{heatpenalty}^{1303} = KW_{Controlled} * Hours * (ESF_{EE} - ESF_{Base}) * -IFkWh$$

Where:

$IFkWh$  = Lighting-HVAC Interaction Factor for electric heating impacts; this factor represents the increased electric space heating requirements due to the reduction of waste heat rejected by the efficient lighting. Values are provided in the Reference Table in Section 4.5. If unknown, use the Miscellaneous value.

### SUMMER COINCIDENT PEAK DEMAND SAVINGS

$$\Delta kW = KW_{controlled} * WHF_d * ((CF_{baseline} * BaseAdj) - CF_{LC})$$

Where:

$WHF_d$  = Waste Heat Factor for Demand to account for cooling savings from efficient lighting in cooled buildings is provided in the Reference Table in Section 4.5. If the building is un-cooled  $WHF_d$  is 1.

$CF_{baseline}$  = Baseline Summer Peak Coincidence Factor for the lighting system without lighting controls installed selected from the Reference Table in Section 4.5 for each building type. If the building type is unknown, use the Miscellaneous value of 0.66

$BaseAdj$  = Assume 0.5 if existing lighting controls, 1.0 if no existing controls

$CF_{LC}$  = Retrofit Summer Peak Coincidence Factor the lighting system with lighting controls installed is 0.15 regardless of building type.<sup>1304</sup>

For controls on exterior fixtures  $\Delta kW = 0$

### FOSSIL FUEL SAVINGS

$$\Delta \text{therms} = KW_{Controlled} * Hours * (ESF_{EE} - ESF_{Base}) * -IFTherms$$

Where:

$IFTherms$  = Lighting-HVAC Integration Factor for gas heating impacts; this factor represents the increased gas space heating requirements due to the reduction of waste heat rejected by the efficient lighting and provided in the Reference Table in Section 4.5 by building type.

### WATER IMPACT DESCRIPTIONS AND CALCULATION

N/A

<sup>1303</sup> Negative value because this is an increase in heating consumption due to the efficient lighting.

<sup>1304</sup> Coincidence Factor Study Residential and Commercial Industrial Lighting Measures, RLW Analytics, Spring 2007. Note, the connected load used in the calculation of the CF for occupancy sensor lights includes the average ESF.

**DEEMED O&M COST ADJUSTMENT CALCULATION**

N/A

**MEASURE CODE: CI-LTG-OSLC-V08-240101**

**REVIEW DEADLINE: 1/1/2026**

## 4.5.11 Solar Light Tubes

### DESCRIPTION

A tubular skylight which is 10” to 21” in diameter with a prismatic or translucent lens is installed on the roof of a commercial facility. The lens reflects light captured from the roof opening through a highly specular reflective tube down to the mounted fixture height. When in use, a light tube fixture resembles a metal halide fixture. Uses include grocery, school, retail and other single story commercial buildings.

In order that the savings characterized below apply, the electric illumination in the space must be automatically controlled to turn off or down when the tube is providing enough light.

This measure was developed to be applicable to the following program types: TOS, NC, RF.

If applied to other program types, the measure savings should be verified.

### DEFINITION OF EFFICIENT EQUIPMENT

The efficient equipment is assumed to be a tubular skylight that concentrates and directs light from the roof to an area inside the facility.

### DEFINITION OF BASELINE EQUIPMENT

The baseline equipment for this measure is a fixture with comparable luminosity. The specifications for the baseline lamp depend on the size of the Light Tube being installed.

### DEEMED LIFETIME OF EFFICIENT EQUIPMENT

The estimated useful life for a light tube commercial skylight is 10 years.<sup>1305</sup>

### DEEMED MEASURE COST

If available, the actual incremental cost should be used. For analysis purposes, assume an incremental cost for a light tube commercial skylight is \$750.<sup>1306</sup>

### LOADSHAPE

Loadshape C14 - Indust. 1-shift (8/5) (e.g., comp. air, lights)<sup>1307</sup>

### COINCIDENCE FACTOR

The summer peak coincidence factor for this measure is dependent on location.

---

### Algorithm

---

### CALCULATION OF SAVINGS

#### ELECTRIC ENERGY SAVINGS

$$\Delta\text{kWh} = \text{kW}_f * \text{HOURS} * \text{WHFe}$$

Where:

$\text{kW}_f$  = Connected load of the fixture the solar tube replaces

<sup>1305</sup> Equal to the manufacturers standard warranty.

<sup>1306</sup> Based on review of solar lighting installers websites (e.g., elitesolarsystems.com).

<sup>1307</sup> The savings from solar light tubes are only realized during the sunlight hours. It is therefore appropriate to apply the single shift (8/5) loadshape to this measure.

Size of Tube	Average Lumen output for Chicago Illinois (minimum) <sup>1308</sup>	Equivalent fixture	kW
21"	9,775 (4,179)	50% 3 x 2 32W lamp CFL (207W, 9915 lumens) 50% 4 lamp F32 w/Elec 4' T8 (114W, 8895 lumens)	0.161
14"	4,392 (1,887)	50% 2 42W lamp CFL (94W, 4406 lumens) 50% 2 lamp F32 w/Elec 4' T8 (59W, 4448 lumens)	0.077
10"	2,157 (911)	50% 1 42W lamp CFL (46W, 2203 lumens) 50% 1 lamp F32 w/Elec 4' T8 (32W, 2224 lumens)	0.039
		<b>AVERAGE</b>	<b>0.092</b>

HOURS = Equivalent full load hours  
= 2400<sup>1309</sup>

WHF<sub>e</sub> = Waste heat factor for energy to account for cooling energy savings from efficient lighting is selected from the Reference Table in Section 4.5 for each building type. If building is un-cooled, the value is 1.0.

**HEATING PENALTY**

If electrically heated building:

$$\Delta kWh_{\text{heatpenalty}}^{1310} = kW_f * \text{HOURS} * -IFkWh$$

Where:

IFkWh = Lighting-HVAC Interaction Factor for electric heating impacts; this factor represents the increased electric space heating requirements due to the reduction of waste heat rejected by the efficient lighting. Values are provided in the Reference Table in Section 4.5. If unknown, use the Miscellaneous value.

**SUMMER COINCIDENT PEAK DEMAND SAVINGS**

$$\Delta kW = \Delta kW_f * WHFd * CF$$

Where:

WHFd = Waste Heat Factor for Demand to account for cooling savings from efficient lighting in cooled buildings is selected from the Reference Table in Section 4.5 for each building type. If the building is not cooled WHFd is 1.

CF = Summer Peak Coincidence Factor for measure is selected from the Reference Table in Section 4.5 for each building type. If the building type is unknown, use the Miscellaneous value of 0.66.

**FOSSIL FUEL SAVINGS**

$$\Delta \text{Therms}^{1311} = \Delta kW_f * \text{HOURS} * -IF\text{Therms}$$

Where:

<sup>1308</sup> Solatube Test Report (2005). [http://www.maine绿色建筑.com/files/file/solatube/stb\\_lumens\\_datasheet.pdf](http://www.maine绿色建筑.com/files/file/solatube/stb_lumens_datasheet.pdf).

<sup>1309</sup> Ibid. The lumen values presented in the kW table represent the average of the lightest 2400 hours.

<sup>1310</sup> Negative value because this is an increase in heating consumption due to the efficient lighting.

<sup>1311</sup> Negative value because this is an increase in heating consumption due to the efficient lighting.

IFTherms = Lighting-HVAC Integration Factor for gas heating impacts; this factor represents the increased gas space heating requirements due to the reduction of waste heat rejected by the efficient lighting. Please select from the Reference Table in Section 4.5 for each building type.

**WATER IMPACT DESCRIPTIONS AND CALCULATION**

N/A

**DEEMED O&M COST ADJUSTMENT CALCULATION**

N/A

**MEASURE CODE: CI-LTG-STUB-V03-200101**

**REVIEW DEADLINE: 1/1/2025**

## 4.5.12 T5 Fixtures and Lamps

### DESCRIPTION

T5 Lamp/ballast systems have higher lumens per watt than a standard T8 or an existing T8 or T12 system. The smaller lamp diameter allows for better optical systems, and more precise control of lighting. These characteristics result in light fixtures that produce equal or greater light than standard T8 or T12 fixtures, while using fewer watts.

This measure applies to the installation of new equipment with efficiencies that exceed that of the equipment that would have been installed following standard market practices and is applicable to time of sale as well as retrofit measures.

If the implementation strategy does not allow for the installation location to be known, a deemed split of 99% Commercial and 1% Residential should be used.<sup>1312</sup>

This measure was developed to be applicable to the following program types: TOS, EREP, DI.

If applied to other program types, the measure savings should be verified.

The measure applies to all commercial T5 installations excluding new construction and substantial renovation or change of use measures (see lighting power density measure). Lookup tables have been provided to account for various installations. Actual existing equipment wattages should be compared to new fixture wattages whenever possible while maintaining lumen equivalent designs. Default new and baseline assumptions are provided if existing equipment cannot be determined. Actual costs and hours of use should be utilized when available. Default component costs and lifetimes have been provided for Operating and Maintenance Calculations. Please see the Definition Table to determine applicability for each program. Configurations not included in the TRM may be included in custom program design using the provided algorithms as long as energy savings is achieved. The following table defines the applicability for different programs:

Time of Sale (TOS)	Early Replacement (EREP) and DI
<p>This program applies to installations where customer and location of equipment is not known, or at time of burnout of existing equipment. T5 Lamp/ballast systems have higher lumens per watt than a standard T8 system. The smaller lamp diameter allows for better optical systems, and more precise control of lighting. These characteristics result in light fixtures that produce equal or greater light than standard T8 fixtures, while using fewer watts.</p>	<p>For installations that upgrade installations before the end of their useful life. T5 Lamp/ballast systems have higher lumens per watt than a standard T8 or T12 system. The smaller lamp diameter allows for better optical systems, and more precise control of lighting. These characteristics result in light fixtures that produce equal or greater light than standard T8 or T12 fixtures, while using fewer watts and having longer life.</p>

### DEFINITION OF EFFICIENT EQUIPMENT

The definition of efficient equipment varies based on the program and is defined below:

Time of Sale (TOS)	Early Replacement (EREP) and DI
<p>4' fixtures must use a T5 lamp and ballast configuration. 1' and 3' lamps are not eligible. High Performance Troffers must be 85% efficient or greater. T5 HO high bay fixtures must be 3, 4 or 6 lamps and 90% efficient or better.</p>	<p>4' fixtures must use a T5 lamp and ballast configuration. 1' and 3' lamps are not eligible. High Performance Troffers must be 85% efficient or greater. T5 HO high bay fixtures must be 3, 4 or 6 lamps and 90% efficient or better.</p>

<sup>1312</sup> Based on weighted average of Final ComEd's BILD program data from PY5 and PY6. For Residential installations, hours of use assumptions from '5.5 Interior Hardwired Compact Fluorescent Lamp (CFL) Fixture' measure should be used.



**DEFINITION OF BASELINE EQUIPMENT**

The definition of baseline equipment varies based on the program and is defined below:

Time of Sale (TOS)	Early Replacement (EREP) and DI
<p>The baseline is T8 with equivalent lumen output. In high-bay applications, the baseline is pulse start metal halide systems.</p>	<p>The baseline is the existing system.                      In July 14, 2012, Federal Standards were enacted that were expected to eliminate T-12s as an option for linear fluorescent fixtures. Through v3.0 of the TRM, it was assumed that the T-12 would no longer be baseline for retrofits from 1/1/2016. However, due to significant loopholes in the legislation, T-12 compliant product is still freely available and in Illinois T-12s continue to hold a significant share of the existing and replacement lamp market. Therefore the timing of the sunseting of T-12s as a viable baseline has been pushed back in v7.0 until 1/1/2020 and will be revisited in future update sessions.                      There will be a baseline shift applied to all measures installed before 2020 in years remaining in the measure life. See table C-1.</p>

**DEEMED LIFETIME OF EFFICIENT EQUIPMENT**

The lifetime of the efficient equipment fixture should be the rated life of the fixture divided by hours of use. If unknown default is, regardless of program type is 12 years.<sup>1313</sup>

**LOADSHAPE**

- Loadshape C06 - Commercial Indoor Lighting
- Loadshape C07 - Grocery/Conv. Store Indoor Lighting
- Loadshape C08 - Hospital Indoor Lighting
- Loadshape C09 - Office Indoor Lighting
- Loadshape C10 - Restaurant Indoor Lighting
- Loadshape C11 - Retail Indoor Lighting
- Loadshape C12 - Warehouse Indoor Lighting
- Loadshape C13 - K-12 School Indoor Lighting
- Loadshape C14 - Indust. 1-shift (8/5) (e.g., comp. air, lights)
- Loadshape C15 - Indust. 2-shift (16/5) (e.g., comp. air, lights)
- Loadshape C16 - Indust. 3-shift (24/5) (e.g., comp. air, lights)
- Loadshape C17 - Indust. 4-shift (24/7) (e.g., comp. air, lights)
- Loadshape C18 - Industrial Indoor Lighting
- Loadshape C19 - Industrial Outdoor Lighting
- Loadshape C20 - Commercial Outdoor Lighting

<sup>1313</sup> 12 years is based on average of mostly CEE lamp products (9 years), T5 lamps (10.7 years) and GDS Measure Life Report, June 2007, (15 years), as recommended in Navigant ‘ComEd Effective Useful Life Research Report’, May 2018.

**Algorithm**

**CALCULATION OF SAVINGS**

**ELECTRIC ENERGY SAVINGS**

$$\Delta kWh = ((Watts_{base} - Watts_{EE}) / 1000) * Hours * WHF_e * ISR$$

Where:

**Watts<sub>base</sub>** = Input wattage of the existing system which depends on the baseline fixture configuration (number and type of lamp) and number of fixtures. Value can be selected from the appropriate reference table as shown below, of a custom value can be entered if the configurations in the tables is not representative of the existing system.

**Watts<sub>EE</sub>** = New Input wattage of EE fixture which depends on new fixture configuration (number of lamps) and ballast factor and number of fixtures. Value can be selected from the appropriate reference table as shown below, of a custom value can be entered if the configurations in the tables is not representative of the existing system.

Program	Reference Table
Time of Sale	A-1: T5 New and Baseline Assumptions
Early Replacement, DI	A-2: T5 New and Baseline Assumptions

**Hours** = Average hours of use per year as provided by the customer or selected from the Reference Table in Section 4.5, Fixture annual operating hours, by building type. If hours or building type are unknown, use the Miscellaneous value.

**WHF<sub>e</sub>** = Waste heat factor for energy to account for cooling energy savings from efficient lighting is selected from the Reference Table in Section 4.5 for each building type. If building is un-cooled, the value is 1.0.

**ISR** = In Service Rate or the percentage of units rebated that get installed.  
 =100%<sup>1314</sup> if application form completed with sign off that equipment is not placed into storage. If sign off form not completed assume the following 3 year ISR assumptions:

Weighted Average 1 <sup>st</sup> year In Service Rate (ISR)	2 <sup>nd</sup> year Installations	3 <sup>rd</sup> year Installations	Final Lifetime In Service Rate
98% <sup>1315</sup>	0%	0%	98.0% <sup>1316</sup>

**HEATING PENALTY**

If electrically heated building:

<sup>1314</sup> Illinois evaluation of PY1 through PY3 has not found that fixtures or lamps placed into storage to be a significant enough issue to warrant including an "In-Service Rate" when commercial customers complete an application form.

<sup>1315</sup> 1<sup>st</sup> year in service rate is based upon review of PY5-6 evaluations from ComEd's commercial lighting program (BILD) (see 'IL Commercial Lighting ISR\_2014.xls' for more information).

<sup>1316</sup> The 98% Lifetime ISR assumption is based upon review of two evaluations:

'Nexus Market Research, RLW Analytics and GDS Associates study; "New England Residential Lighting Markdown Impact Evaluation, January 20, 2009' and 'KEMA Inc, Feb 2010, Final Evaluation Report: Upstream Lighting Program, Volume 1.' This implies that only 2% of bulbs purchased are never installed. The second and third year installations are based upon Ameren analysis of the Californian KEMA study showing that 54% of future installs occur in year 2 and 46% in year 3. The 2<sup>nd</sup> and 3<sup>rd</sup> year installations should be counted as part of those future program year savings.

$$\Delta kWh_{\text{heatpenalty}}^{1317} = ((\text{WattsBase}-\text{WattsEE})/1000) * \text{ISR} * \text{Hours} * -\text{IFkWh}$$

Where:

IFkWh = Lighting-HVAC Interaction Factor for electric heating impacts; this factor represents the increased electric space heating requirements due to the reduction of waste heat rejected by the efficient lighting. Values are provided in the Reference Table in Section 4.5. If unknown, use the Miscellaneous value.

**SUMMER COINCIDENT DEMAND SAVINGS**

$$\Delta kW = ((\text{Watts}_{\text{base}}-\text{Watts}_{\text{EE}})/1000) * \text{WHF}_d * \text{CF} * \text{ISR}$$

Where:

WHF<sub>d</sub> = Waste Heat Factor for Demand to account for cooling savings from efficient lighting in cooled buildings is selected from the Reference Table in Section 4.5 for each building type. If the building is not cooled WHF<sub>d</sub> is 1.

CF = Summer Peak Coincidence Factor for measure is selected from the Reference Table in Section 4.5 for each building type. If the building type is unknown, use the Miscellaneous value.

**FOSSIL FUEL SAVINGS**

$$\Delta \text{Therms}^{1318} = ((\text{WattsBase}-\text{WattsEE})/1000) * \text{ISR} * \text{Hours} * -\text{IFTherms}$$

Where:

IFTherms = Lighting-HVAC Integration Factor for gas heating impacts; this factor represents the increased gas space heating requirements due to the reduction of waste heat rejected by the efficient lighting. This value is selected from the Reference Table in Section 4.5 for each building type.

**WATER IMPACT DESCRIPTIONS AND CALCULATION**

N/A

**DEEMED O&M COST ADJUSTMENT CALCULATION**

See Reference tables for Operating and Maintenance Values

Program	Reference Table
Time of Sale	B-1: T5 Component Costs and Lifetime
Early Replacement, DI	B-2: T5 Component Costs and Lifetime

**REFERENCE TABLES**

See following page.

<sup>1317</sup>Negative value because this is an increase in heating consumption due to the efficient lighting.

<sup>1318</sup>Negative value because this is an increase in heating consumption due to the efficient lighting.

A-1: Time of Sale: T5 New and Baseline Assumptions<sup>1319</sup>

EE Measure Description	EE Cost	Watts <sub>EE</sub>	Baseline Description	Base Cost	Watts <sub>BASE</sub>	Measure Cost	Watts <sub>SAVE</sub>
2-Lamp T5 High-Bay	\$200.00	180	200 Watt Pulse Start Metal-Halide	\$100.00	232	\$100.00	52
3-Lamp T5 High-Bay	\$200.00	180	200 Watt Pulse Start Metal-Halide	\$100.00	232	\$100.00	52
4-Lamp T5 High-Bay	\$225.00	240	320 Watt Pulse Start Metal-Halide	\$125.00	350	\$100.00	110
6-Lamp T5 High-Bay	\$250.00	360	Proportionally Adjusted according to 6-Lamp HPT8 Equivalent to 320 PSMH	\$150.00	476	\$100.00	116
1-Lamp T5 Troffer/Wrap	\$100.00	32	Proportionally adjusted according to 2-Lamp T5 Equivalent to 3-Lamp T8	\$60.00	44	\$40.00	12
2-Lamp T5 Troffer/Wrap	\$100.00	64	3-Lamp F32T8 Equivalent w/ Elec. Ballast	\$60.00	88	\$40.00	24
1-Lamp T5 Industrial/Strip	\$70.00	32	Proportionally adjusted according to 2-Lamp T5 Equivalent to 3-Lamp T8	\$40.00	44	\$30.00	12
2-Lamp T5 Industrial/Strip	\$70.00	64	3-Lamp F32T8 Equivalent w/ Elec. Ballast	\$40.00	88	\$30.00	24
3-Lamp T5 Industrial/Strip	\$70.00	96	Proportionally adjusted according to 2-Lamp T5 Equivalent to 3-Lamp T8	\$40.00	132	\$30.00	36
4-Lamp T5 Industrial/Strip	\$70.00	128	Proportionally adjusted according to 2-Lamp T5 Equivalent to 3-Lamp T8	\$40.00	178	\$30.00	50
1-Lamp T5 Indirect	\$175.00	32	Proportionally adjusted according to 2-Lamp T5 Equivalent to 3-Lamp T8	\$145.00	44	\$30.00	12
2-Lamp T5 Indirect	\$175.00	64	3-Lamp F32T8 Equivalent w/ Elec. Ballast	\$145.00	88	\$30.00	24

<sup>1319</sup> Adapted from Efficiency Vermont Technical Reference User Manual (TRM) Measure Savings Algorithms and Cost Assumptions, October 26, 2011.

A-2: T5 New and Baseline Assumptions<sup>1320</sup>

EE Measure Description	EE Cost	Watts <sub>EE</sub>
3-Lamp T5 High-Bay	\$200.00	180
4-Lamp T5 High-Bay	\$225.00	234
6-Lamp T5 High-Bay	\$250.00	358
1-Lamp T5 Troffer/Wrap	\$100.00	32
2-Lamp T5 Troffer/Wrap	\$100.00	64
1-Lamp T5 Industrial/Strip	\$70.00	32
2-Lamp T5 Industrial/Strip	\$70.00	64
3-Lamp T5 Industrial/Strip	\$70.00	96
4-Lamp T5 Industrial/Strip	\$70.00	128
1-Lamp T5 Indirect	\$175.00	32
2-Lamp T5 Indirect	\$175.00	64

Baseline Description	Watts <sub>BASE</sub>
200 Watt Pulse Start Metal-Halide	232
250 Watt Metal-Halide	295
320 Watt Pulse Start Metal-Halide	350
400 Watt Metal-Halide	455
400 Watt Pulse Start Metal-Halide	476
1-Lamp F34T12 w/ EEMag Ballast	40
2-Lamp F34T12 w/ EEMag Ballast	68
3-Lamp F34T12 w/ EEMag Ballast	110
4-Lamp F34T12 w/ EEMag Ballast	139
1-Lamp F40T12 w/ EEMag Ballast	48
2-Lamp F40T12 w/ EEMag Ballast	82
3-Lamp F40T12 w/ EEMag Ballast	122
4-Lamp F40T12 w/ EEMag Ballast	164
1-Lamp F40T12 w/ Mag Ballast	57
2-Lamp F40T12 w/ Mag Ballast	94
3-Lamp F40T12 w/ Mag Ballast	147
4-Lamp F40T12 w/ Mag Ballast	182
1-Lamp F32T8	32
2-Lamp F32T8	59
3-Lamp F32T8	88
4-Lamp F32T8	114

<sup>1320</sup>bid.

B-1: Time of Sale T5 Component Costs and Lifetime<sup>1321</sup>

EE Measure Description	EE Lamp Cost	EE Lamp Life (hrs)	EE Lamp Rep. Labor Cost per lamp	EE Ballast Cost	EE Ballast Life (hrs)	EE Ballast Rep. Labor Cost	Baseline Description	# Base Lamps	Base Lamp Cost	Base Lamp Life (hrs)	Base Lamp Rep. Labor Cost	# Base Ballasts	Base Ballast Cost	Base Ballast Life (hrs)	Base Ballast Rep. Labor Cost
3-Lamp T5 High-Bay	\$12.00	20000	\$6.67	\$52.00	70000	\$22.50	200 Watt Pulse Start Metal-Halide	1.00	\$21.00	10000	\$6.67	1.00	\$87.75	40000	\$22.50
4-Lamp T5 High-Bay	\$12.00	20000	\$6.67	\$52.00	70000	\$22.50	320 Watt Pulse Start Metal-Halide	1.00	\$21.00	20000	\$6.67	1.00	\$109.35	40000	\$22.50
6-Lamp T5 High-Bay	\$12.00	20000	\$6.67	\$52.00	70000	\$22.50	Adjusted according to 6-Lamp HPT8 Equivalent to 320	1.36	\$21.00	20000	\$6.67	1.50	\$109.35	40000	\$22.50
1-Lamp T5 Troffer/Wrap	\$12.00	20000	\$2.67	\$52.00	70000	\$15.00	Proportionally adjusted according to 2-Lamp T5 Equivalent to 3-Lamp T8	1.50	\$2.50	20000	\$2.67	0.50	\$15.00	70000	\$15.00
2-Lamp T5 Troffer/Wrap	\$12.00	20000	\$2.67	\$52.00	70000	\$15.00	3-Lamp F32T8 Equivalent w/ Elec. Ballast	3.00	\$2.50	20000	\$2.67	1.00	\$15.00	70000	\$15.00
1-Lamp T5 Industrial/Strip	\$12.00	20000	\$2.67	\$52.00	70000	\$15.00	Proportionally adjusted according to 2-Lamp T5 Equivalent to 3-Lamp T8	1.50	\$2.50	20000	\$2.67	0.50	\$15.00	70000	\$15.00
2-Lamp T5 Industrial/Strip	\$12.00	20000	\$2.67	\$52.00	70000	\$15.00	3-Lamp F32T8 Equivalent w/ Elec. Ballast	3.00	\$2.50	20000	\$2.67	1.00	\$15.00	70000	\$15.00
3-Lamp T5 Industrial/Strip	\$12.00	20000	\$2.67	\$52.00	70000	\$15.00	Proportionally adjusted according to 2-Lamp T5 Equivalent	4.50	\$2.50	20000	\$2.67	1.50	\$15.00	70000	\$15.00
4-Lamp T5 Industrial/Strip	\$12.00	20000	\$2.67	\$52.00	70000	\$15.00	Proportionally adjusted according to 2-Lamp T5 Equivalent to 3-Lamp T8	6.00	\$2.50	20000	\$2.67	2.00	\$15.00	70000	\$15.00
1-Lamp T5 Indirect	\$12.00	20000	\$2.67	\$52.00	70000	\$15.00	Proportionally adjusted according to 2-Lamp T5 Equivalent to 3-Lamp T8	1.50	\$2.50	20000	\$2.67	0.50	\$15.00	70000	\$15.00
2-Lamp T5 Indirect	\$12.00	20000	\$2.67	\$52.00	70000	\$15.00	3-Lamp F32T8 Equivalent w/ Elec. Ballast	3.00	\$2.50	20000	\$2.67	1.00	\$15.00	70000	\$15.00

<sup>1321</sup> Adapted from Efficiency Vermont Technical Reference User Manual (TRM) Measure Savings Algorithms and Cost Assumptions, October 26, 2011.

B-2: T5 Component Costs and Lifetime<sup>1322</sup>

EE Measure Description	EE Lamp Cost	EE Lamp Life (hrs)	EE Lamp Rep. Labor Cost per lamp	EE Ballast Cost	EE Ballast Life (hrs)	EE Ballast Rep. Labor Cost	Baseline Description	# Base Lamps	Base Lamp Cost	Base Lamp Life (hrs)	Base Lamp Rep. Labor Cost	# Base Ballasts	Base Ballast Cost	Base Ballast Life (hrs)	Base Ballast Rep. Labor Cost
3-Lamp T5 High-Bay	\$12.00	20000	\$6.67	\$52.00	70000	\$22.50	200 Watt Pulse Start Metal-Halide	1.00	\$21.00	10000	\$6.67	1.00	\$ 88	40000	\$22.50
							250 Watt Metal Halide	1.00	\$21.00	10000	\$6.67	1.00	\$ 92	40000	\$22.50
4-Lamp T5 High-Bay	\$12.00	20000	\$6.67	\$52.00	70000	\$22.50	320 Watt Pulse Start Metal-Halide	1.00	\$72.00	20000	\$6.67	1.00	\$ 109	40000	\$22.50
							400 Watt Metal Halide	1.00	\$17.00	20000	\$6.67	1.00	\$ 114	40000	\$22.50
6-Lamp T5 High-Bay	\$12.00	20000	\$6.67	\$52.00	70000	\$22.50	Proportionally Adjusted according to 6-Lamp HPT8 Equivalent to 320 PSMH	1.36	\$72.00	20000	\$6.67	1.50	\$ 109	40000	\$22.50
1-Lamp T5 Troffer/Wrap	\$12.00	20000	\$2.67	\$52.00	70000	\$15.00	Proportionally adjusted according to 2-Lamp T5 Equivalent to 3-Lamp T8	1.50	\$2.50	20000	\$2.67	0.50	\$ 15	70000	\$15.00
2-Lamp T5 Troffer/Wrap	\$12.00	20000	\$2.67	\$52.00	70000	\$15.00	3-Lamp F32T8 Equivalent w/ Elec. Ballast	3.00	\$2.50	20000	\$2.67	1.00	\$ 15	70000	\$15.00
1-Lamp T5 Industrial/Strip	\$12.00	20000	\$2.67	\$52.00	70000	\$15.00	Proportionally adjusted according to 2-Lamp T5 Equivalent to 3-Lamp T8	1.50	\$2.50	20000	\$2.67	0.50	\$ 15	70000	\$15.00
2-Lamp T5 Industrial/Strip	\$12.00	20000	\$2.67	\$52.00	70000	\$15.00	3-Lamp F32T8 Equivalent w/ Elec. Ballast	3.00	\$2.50	20000	\$2.67	1.00	\$ 15	70000	\$15.00
3-Lamp T5 Industrial/Strip	\$12.00	20000	\$2.67	\$52.00	70000	\$15.00	Proportionally adjusted according to 2-Lamp T5 Equivalent to 3-Lamp T8	4.50	\$2.50	20000	\$2.67	1.50	\$ 15	70000	\$15.00
4-Lamp T5 Industrial/Strip	\$12.00	20000	\$2.67	\$52.00	70000	\$15.00	Proportionally adjusted according to 2-Lamp T5 Equivalent to 3-Lamp T8	6.00	\$2.50	20000	\$2.67	2.00	\$ 15	70000	\$15.00
1-Lamp T5 Indirect	\$12.00	20000	\$2.67	\$52.00	70000	\$15.00	Proportionally adjusted according to 2-Lamp T5 Equivalent to 3-Lamp T8	1.50	\$2.50	20000	\$2.67	0.50	\$ 15	70000	\$15.00
2-Lamp T5 Indirect	\$12.00	20000	\$2.67	\$52.00	70000	\$15.00	3-Lamp F32T8 Equivalent w/ Elec. Ballast	3.00	\$2.50	20000	\$2.67	1.00	\$ 15	70000	\$15.00

<sup>1322</sup> Efficiency Vermont Technical Reference User Manual (TRM) Measure Savings Algorithms and Cost Assumptions, October 26, 2011 EPE Program Downloads. (Copy of LSF\_2012\_v4.04\_250rows.xls). Kuiken et al, Focus on Energy Evaluation. Business Programs: Deemed Savings Manual v1.0, Kema, March 22, 2010.

C-1: T12 Baseline Adjustment:

For early replacement measures replacing existing T12 fixtures the full savings (as calculated above in the Algorithm section) will be claimed for the remaining useful life of the T12 fixture. This should be calculated as follows:

$$\text{RUL of existing T12 fixture} = (1/3 * 40,000)/\text{Hours.}$$

A savings adjustment should then be applied to the annual savings for the remainder of the measure life. The adjustment to be applied for each measure should be calculated as:

$$\% \text{ Adjustment} = (\text{TOS Base Watts} - \text{Efficient Watts}) / (\text{Existing T12 Watts} - \text{Efficient Watts})$$

The adjustment to be applied for each default measure described above is listed in the reference table below:

Savings Adjustment Factors

	watts	Equivalent T12 watts adjusted for lumen equivalency-34 w and 40 w with EEMag ballast	Equivalent T12 watts adjusted for lumen equivalency-40 w with EEMag ballast	Equivalent T12 watts adjusted for lumen equivalency-40 w with Mag ballast	Prportionally Adjusted for Lumens wattage for T8 equivalent
1-Lamp T5 Industrial/Strip	32	61	73	82	44
2-Lamp T5 Industrial/Strip	64	103	125	135	88
3-Lamp T5 Industrial/Strip	96	167	185	211	132
4-Lamp T5 Industrial/Strip	128	211	249	226	178
		Savings Factor Adjustment to the T8 baseline	Savings Factor Adjustment to the T8 baseline	Savings Factor Adjustment to the T8 baseline	
1-Lamp T5 Industrial/Strip		42%	29%	24%	
2-Lamp T5 Industrial/Strip		61%	40%	34%	
3-Lamp T5 Industrial/Strip		51%	40%	31%	
4-Lamp T5 Industrial/Strip		60%	41%	51%	

**MEASURE CODE: CI-LTG-T5FX-V08-200101**

**REVIEW DEADLINE: 1/1/2025**



### 4.5.13 Occupancy Controlled Bi-Level Lighting Fixtures

#### DESCRIPTION

This measure relates to replacing existing uncontrolled continuous lighting fixtures with new bi-level lighting fixtures. This measure can only relate to replacement in an existing building, since multi-level switching is required in the Commercial new construction building energy code (IECC 2012/2015/2018/2021).

This measure was developed to be applicable to the following program types: RF.

If applied to other program types, the measure savings should be verified.

#### DEFINITION OF EFFICIENT EQUIPMENT

In order for this characterization to apply, the efficient system is assumed to be an occupancy controlled lighting fixture that reduces light level during unoccupied periods.

#### DEFINITION OF BASELINE EQUIPMENT

The baseline equipment is assumed to be an uncontrolled lighting system on continuously, e.g. in stairwells and corridors for health and safety reasons.

#### DEEMED LIFETIME OF EFFICIENT EQUIPMENT

The expected measure life for all lighting controls is assumed to be 10 years.<sup>1323</sup>

#### DEEMED MEASURE COST

When available, the actual cost of the measure shall be used. When not available, the assumed measure cost is \$274.<sup>1324</sup>

#### LOADSHAPE

- Loadshape C06 - Commercial Indoor Lighting
- Loadshape C07 - Grocery/Conv. Store Indoor Lighting
- Loadshape C08 - Hospital Indoor Lighting
- Loadshape C09 - Office Indoor Lighting
- Loadshape C10 - Restaurant Indoor Lighting
- Loadshape C11 - Retail Indoor Lighting
- Loadshape C12 - Warehouse Indoor Lighting
- Loadshape C13 - K-12 School Indoor Lighting
- Loadshape C14 - Indust. 1-shift (8/5) (e.g., comp. air, lights)
- Loadshape C15 - Indust. 2-shift (16/5) (e.g., comp. air, lights)
- Loadshape C16 - Indust. 3-shift (24/5) (e.g., comp. air, lights)
- Loadshape C17 - Indust. 4-shift (24/7) (e.g., comp. air, lights)
- Loadshape C18 - Industrial Indoor Lighting
- Loadshape C19 - Industrial Outdoor Lighting
- Loadshape C20 - Commercial Outdoor Lighting

---

<sup>1323</sup> Consistent with Lighting Controls measure.

<sup>1324</sup> Consistent with the Multi-level Fixture measure with reference to Goldberg et al, State of Wisconsin Public Service Commission of Wisconsin, Focus on Energy Evaluation, Business Programs: Incremental Cost Study, KEMA, October 28, 2009. Also consistent with field experience of about \$250 per fixture and \$25 install labor.

**COINCIDENCE FACTOR**

The summer peak coincidence factor for this measure is dependent on the location type. Values are provided for each building type in the reference section below.

**Algorithm**

**CALCULATION OF SAVINGS**

**ELECTRIC ENERGY SAVINGS**

$$\Delta kWh = (KW_{Baseline} - (KW_{Controlled} * (1 - ESF))) * Hours * WHF_e$$

Where:

$KW_{Baseline}$  = Total baseline lighting load of the existing/baseline fixture  
 = Actual

Note that if the existing fixture is only being retrofit with bi-level occupancy controls and not being replaced  $KW_{Baseline}$  will equal  $KW_{Controlled}$ .

$KW_{Controlled}$  = Total controlled lighting load at full light output of the new bi-level fixture  
 = Actual

Hours = Number of hours lighting is on. This measure is limited to 24/7 operation.  
 = 8,766

ESF = Energy Savings factor (represents the percentage reduction to the  $KW_{Controlled}$  due to the occupancy control).  
 = % Standby Mode \* (1 - % Full Light at Standby Mode)

% Standby Mode = Represents the percentage of the time the fixture is operating in standby (i.e. low-wattage) mode.

% Full Light at Standby Mode = Represents the assumed wattage consumption during standby mode relative to the full wattage consumption. Can be achieved either through dimming or a stepped control strategy.

= Dependent on application. If participant provided or metered data is available for both or either of these inputs a custom savings factor should be calculated. If not defaults are provided below:

Application	% Standby Mode	% Full Light at Standby Mode	Energy Savings Factor (ESF)
Stairwells	78.5% <sup>1325</sup>	50%	39.3%
		33%	52.6%
		10%	70.7%
		5%	74.6%
Corridors	50.0% <sup>1326</sup>	50%	25.0%
		33%	33.5%

<sup>1325</sup> Average found from the four buildings in the State of California Energy Commission Lighting Research Program Bi-Level Stairwell Fixture Performance Final Report, October 2005.

<sup>1326</sup> Value determined from the Pacific Gas and Electric Company: Bi-Level Lighting Control Credits study for Interior Corridors of Hotels, Motels and High Rise Residential, June 2002.

Application	% Standby Mode	% Full Light at Standby Mode	Energy Savings Factor (ESF)
		10%	45.0%
		5%	47.5%
Other 24/7 Space Type	50.0% <sup>1327</sup>	50%	25.0%
		33%	33.5%
		10%	45.0%
		5%	47.5%

WHF<sub>e</sub> = Waste heat factor for energy to account for cooling energy savings from efficient lighting is provided in the Reference Table in Section 4.5 for each building type. If building is un-cooled, the value is 1.0.

**HEATING PENALTY**

If electrically heated building:

$$\Delta kWh_{\text{heatpenalty}}^{1328} = (KW_{\text{Baseline}} - (KW_{\text{Controlled}} * (1 - ESF))) * \text{Hours} * -IFkWh$$

Where:

IFkWh = Lighting-HVAC Interaction Factor for electric heating impacts; this factor represents the increased electric space heating requirements due to the reduction of waste heat rejected by the efficient lighting. Values are provided in the Reference Table in Section 4.5. If unknown, use the Miscellaneous value.

**SUMMER COINCIDENT PEAK DEMAND SAVINGS**

$$\Delta kW = (KW_{\text{Baseline}} - (KW_{\text{Controlled}} * (1 - ESF))) * WHF_d * (CF_{\text{baseline}} - CF_{\text{os}})$$

Where:

WHF<sub>d</sub> = Waste Heat Factor for Demand to account for cooling savings from efficient lighting in cooled buildings is provided in the Reference Table in Section 4.5. If the building is un-cooled WHF<sub>d</sub> is 1.

CF<sub>baseline</sub> = Baseline Summer Peak Coincidence Factor for the lighting system without Occupancy Sensors installed selected from the Reference Table in Section 4.5 for each building type. If the building type is unknown, use the Miscellaneous value of 0.66

CF<sub>os</sub> = Retrofit Summer Peak Coincidence Factor the lighting system with Occupancy Sensors installed is 0.15 regardless of building type.<sup>1329</sup>

**NATURAL GAS HEATING PENALTY**

If natural gas heating:

$$\Delta \text{therms} = (KW_{\text{Baseline}} - (KW_{\text{Controlled}} * (1 - ESF))) * \text{Hours} * -IF\text{Therms}$$

Where:

IFTherms = Lighting-HVAC Integration Factor for gas heating impacts; this factor represents the increased gas space heating requirements due to the reduction of waste heat rejected by the efficient lighting and provided in the Reference Table in Section 4.5 by building type.

<sup>1327</sup> Conservative estimate.

<sup>1328</sup> Negative value because this is an increase in heating consumption due to the efficient lighting.

<sup>1329</sup> Coincidence Factor Study Residential and Commercial Industrial Lighting Measures, RLW Analytics, Spring 2007. Note, the connected load used in the calculation of the CF for occupancy sensor lights includes the average ESF.

**WATER IMPACT DESCRIPTIONS AND CALCULATION**

N/A

**DEEMED O&M COST ADJUSTMENT CALCULATION**

N/A

**MEASURE CODE: CI-LTG-OCBL-V05-230101**

**REVIEW DEADLINE: 1/1/2025**

4.5.14 Commercial ENERGY STAR Specialty Compact Fluorescent Lamp (CFL) – Retired 12/31/2018, Removed in v8

## 4.5.15 LED Open Sign

### DESCRIPTION

LED open signs must replace an existing neon open sign. LED drivers can be either electronic switching or linear magnetic, with the electronic switching supplies being the most efficient. The on/off power switch may be found on either the power line or load side of the driver, with the line side location providing significantly lower standby losses when the sign is turned off and is not operating. All new open signs must meet UL-84 (UL-844) requirements.

Replacement signs cannot use more than 20% of the input power of the sign that is being replaced.

This measure was developed to be applicable to the following program types: RF.

If applied to other program types, the measure savings should be verified.

### DEFINITION OF EFFICIENT EQUIPMENT

The efficient product is an LED type illuminated open sign.

### DEFINITION OF BASELINE EQUIPMENT

The baseline equipment is a neon type illuminated open sign.

### DEEMED LIFETIME OF EFFICIENT EQUIPMENT

The estimated useful life is 15 years.<sup>1330</sup>

### DEEMED MEASURE COST

The actual measure installation cost should be used (including material and labor).

### LOADSHAPE

- Loadshape C06 - Commercial Indoor Lighting
- Loadshape C07 - Grocery/Conv. Store Indoor Lighting
- Loadshape C08 - Hospital Indoor Lighting
- Loadshape C09 - Office Indoor Lighting
- Loadshape C10 - Restaurant Indoor Lighting
- Loadshape C11 - Retail Indoor Lighting
- Loadshape C12 - Warehouse Indoor Lighting
- Loadshape C13 - K-12 School Indoor Lighting
- Loadshape C14 - Indust. 1-shift (8/5) (e.g., comp. air, lights)
- Loadshape C15 - Indust. 2-shift (16/5) (e.g., comp. air, lights)
- Loadshape C16 - Indust. 3-shift (24/5) (e.g., comp. air, lights)
- Loadshape C17 - Indust. 4-shift (24/7) (e.g., comp. air, lights)
- Loadshape C18 - Industrial Indoor Lighting
- Loadshape C19 - Industrial Outdoor Lighting
- Loadshape C20 - Commercial Outdoor Lighting

---

<sup>1330</sup> 15 years from GDS Measure Life Report, June 2007.

### COINCIDENCE FACTOR

The summer peak coincidence factor for this measure is dependent on the location type. Values are provided for each building type in the reference section in Section 4.5.

---

### Algorithm

---

### CALCULATION OF ENERGY SAVINGS

#### ELECTRIC ENERGY SAVINGS

The following equation was used to determine the energy savings from installing LED open signs:

$$\Delta kWh = (Watts_{base} - Watts_{ee}) / 1,000 * Hours * WHFe$$

Where:

- Watts<sub>base</sub> = Wattage of neon sign with magnetic high voltage transformer  
= Actual; if unknown use 46.0W<sup>1331</sup>
- Watts<sub>ee</sub> = Wattage of LED sign with low voltage transformer  
= Actual; if unknown use 14.9W<sup>1332</sup>
- Hours = Annual hours of operation, assumed to be consistent with operating hours. Values are provided in the Reference Table in Section 4.5.
- WHFe = Waste heat factor for energy to account for cooling energy savings from efficient lighting are provided below for each building type in the Reference Table in Section 4.5. If unknown, use the Miscellaneous value.

#### HEATING PENALTY

If electrically heated building:

$$\Delta kWh_{heatpenalty}^{1333} = ((Watts_{base} - Watts_{EE}) / 1000) * Hours * -IFkWh$$

Where:

- IFkWh = Lighting-HVAC Interaction Factor for electric heating impacts; this factor represents the increased electric space heating requirements due to the reduction of waste heat rejected by the efficient lighting. Values are provided in the Reference Table in Section 4.5. If unknown, use the Miscellaneous value.

#### DEMAND SAVINGS

$$\Delta kW = ((Watts_{base} - Watts_{see}) / 1000) * CF * WHFd$$

Where:

- WHFd = Waste Heat Factor for Demand to account for cooling savings from efficient lighting in cooled buildings is provided in Reference Table in Section 4.5. If unknown, use the Miscellaneous value.
- CF = Summer Peak Coincidence Factor for measure is provided in the Reference Table in Section 4.5. If unknown, use the Miscellaneous value.

---

<sup>1331</sup> Measured average demand data. Southern California Edison, "Replace Neon Open Sign with LED Open Sign", Workpaper SCE13LG070, Revision 2, October 2015. Pg. 10.

<sup>1332</sup> Ibid.

<sup>1333</sup> Negative value because this is an increase in heating consumption due to the efficient lighting.

Other variables as provided above.

Based on defaults provided above, the deemed energy savings are provided below:

**Electric Energy and Coincident Peak Demand Savings**

Building Types <sup>1334</sup>	Energy Savings (kWh)	$\Delta kWh_{\text{heatpenalty}}$ (if electric heat)	Coincident Demand Savings (kW)
Convenience Store	158	-120	0.0298
Grocery	152	-74	0.0277
Healthcare Clinic	169	-17	0.0374
Hotel/Motel - Common	229	-143	0.0282
Movie Theater	121	-73	0.0227
Restaurant	203	-85	0.0277
Retail - Department Store	191	-88	0.0387
Miscellaneous	115	-55	0.0245

**FOSSIL FUEL SAVINGS**

Heating Penalty if fossil fuel heated building (or if heating fuel is unknown):

$$\Delta \text{Therms}^{1335} = ((\text{WattsBase} - \text{WattsEE}) / 1000) * \text{Hours} * \text{IFTherms}$$

Where:

IFTherms = Lighting-HVAC Interaction Factor for gas heating impacts; this factor represents the increased gas space heating requirements due to the reduction of waste heat rejected by the efficient lighting. Values are provided in the Reference Table in Section 4.5. If unknown, use the Miscellaneous value.

Other factors as defined above

Based on defaults provided above, the deemed penalty is provided below:

Building Type	$\Delta \text{Therms}_{\text{heatpenalty}}$ (if gas heat)
Convenience Store	-5.1
Grocery	-3.2
Healthcare Clinic	-0.7
Hotel/Motel - Common	-6.1
Movie Theater	-3.2
Restaurant	-3.6
Retail - Department Store	-3.7
Miscellaneous	-2.3

**WATER AND OTHER NON-ENERGY IMPACT DESCRIPTIONS AND CALCULATION**

N/A

**DEEMED O&M COST ADJUSTMENT CALCULATION**

N/A

<sup>1334</sup> Savings can be calculated for additional building types using the default values provided in the Reference Table in Section 4.5.

<sup>1335</sup> Negative value because this is an increase in heating consumption due to the efficient lighting.



**MEASURE CODE: CI-LTG-OPEN-V02-220101**

**REVIEW DEADLINE: 1/1/2026**

## 4.5.16 LED Streetlighting

### DESCRIPTION

Existing streetlights are retrofitted to be illuminated with light emitting diodes (LED) instead of less efficient lamps. Incentive applies for the replacement or retrofit of existing streetlights with new LED lamps.

This measure was developed to be applicable to the following program types: EREP, TOS\*. If applied to other program types, the measure savings should be verified.

\* It is recommended to consider likely high freeridership for time of sale applications of this measure.

### DEFINITION OF EFFICIENT EQUIPMENT

The efficient equipment is the installed LED streetlight.

### DEFINITION OF BASELINE EQUIPMENT

For TOS, baseline is assumed to be High Pressure Sodium lamp.

For early replacement, the baseline equipment is the existing streetlight for its' remaining useful life, and a new baseline High Pressure Sodium lamp for the remainder of the measure life. Where the existing fixture is Mercury Vapor (MV), the following table provides the deemed alignment of Mercury Vapor (MV) fixtures to High Pressure Sodium (HPS) for calculation of the midlife baseline adjustment.<sup>1336</sup>

MV Lamp Watts	MV System Watts	HPS Lamp Watts	HPS System Watts
100	125	50	66
175	205	100	138
250	290	100	138
400	455/469	250	295
1000	1075	400	465

### DEEMED LIFETIME OF EFFICIENT EQUIPMENT

The assumed effective useful life (EUL) of a new LED streetlight is 20 years for standard operation or 10 years for 8766 hour lighting.<sup>1337</sup>

For early replacement, it is assumed the existing unit has a remaining useful life (RUL) of 3 years for standard operation and 1.5 year for 8760 operation.<sup>1338</sup>

<sup>1336</sup> Midlife adjustment data is based on analysis by Guidehouse and is based on two years of AIC and ComEd program data, including 13,270 MV lamps and 96,780 HPS lamps. Both types of retrofits are mapped to the installed LED wattage, the resulting LED correlations are then used as a common frame of reference to align MV fixtures to the closest HPS equivalent. Results are further validated through the lumen equivalence method which confirms the alignments match the next closest lamp wattage, even if some HPS fixtures equate to higher lumen output whereas others provide lower output.

<sup>1337</sup> Based on research conducted by Guidehouse and reported in "ComEd LED St Lighting EUL Results Memo," January 27, 2020, Guidehouse reviewed a cross-section of products covered in 2019 energy conservation programs; these fixtures include the most commonly selected manufacturers and output spanning from 4,000 to 25,000 lumens. This review found that manufactures for the majority of LED streetlights installed through programs in IL have recently doubled the expected rated life to 100,000 hours.

<sup>1338</sup> Assuming an existing mercury vapor ballast with a typical rated life of 40,000. Assuming 1/3 remaining useful life and standard operation this equates to  $40,000/3/4303 = 3$  year remaining life, and  $40,000/3/8760 = 1.5$  year remaining life for 8760 operation.

**DEEMED MEASURE COST**

The actual measure installation cost should be used (including material and labor). The assumed deferred cost (after 3 years for standard operation and 1.5 year for 8760 operation) of replacing the existing lamp with a new High Pressure Sodium lamp is assumed to be \$44.<sup>1339</sup> This cost should be discounted to present value using the nominal discount rate.

**LOADSHAPE**

Loadshape C20 - Commercial Outdoor Lighting

**COINCIDENCE FACTOR**

The summer peak coincidence factor for this measure is assumed to be 0 for standard usage or 1.0 for 8766 hour lighting.<sup>1340</sup>

---



---

**Algorithm**

---



---

**CALCULATION OF ENERGY SAVINGS**

**ELECTRIC ENERGY SAVINGS**

For remaining useful life (1<sup>st</sup> 3 years for standard operation and 1.5 year for 8760 operation) of existing equipment:

$$(1) \quad \Delta kWh = (W_{exist} - W_{eff}) * HOURS / 1000$$

For remaining life of measure (next 17 years for standard operation and 8.5 years for 8760 operation) or time of sale:

$$(2) \quad \Delta kWh = (W_{base} - W_{eff}) * HOURS / 1000$$

Where:

- $W_{exist}$  =the connected load of the existing equipment  
= actual existing equipment wattage
- $W_{base}$  =the connected load of the baseline equipment  
= assume appropriate High Pressure Sodium lamp wattage for application, see mapping table in 'Definition of Baseline Equipment section above'..
- $W_{eff}$  =the connected load of the efficient equipment  
= actual efficient equipment wattage
- EFLH = annual operating hours of the lamp  
= 4,303 hours for standard operation<sup>1341</sup>  
= 8,766 hours for always on lighting

---

<sup>1339</sup> High Pressure Sodium replacement cost (lamp and labor) was provided by ComEd based on their composite maintenance rate.

<sup>1340</sup> Assuming standard operation of streetlight occurs outside the summer peak period of 1-5 PM. Coincidence Factor is assumed to equal 0.

<sup>1341</sup> Based on Navigant verified value using 2014 Astronomical Applications Department, U.S. Naval Observatory data for ComEd's service territory. See Navigant Memorandum 'RE: LED Street Lighting Program Hours of Use for the ComEd and DCEO Programs. June 21, 2017'.

1000 = conversion factor (W/kW)

**Mid Life Baseline Adjustment**

To calculate the mid life adjustment, divide the savings for remaining life of measure (1), by the first year savings (2) as provided above.

**For example**, an existing streetlight that uses a single 175 watt mercury vapor lamp is replaced by a 42W LED fixture. Accounting for ballast factor, the system load for the existing fixture is 205 watts. The HPS equivalent for the midlife adjustment is a 100 W lamp with total system load of 138 W. For a fixture with standard operating profile, the first year and lifetime savings for this installation are found as follows:

$$\begin{aligned} \Delta\text{kWh (first three years)} &= ((205 - 42) * 4,303) / 1000 \\ &= 701.4 \text{ kWh / year} \end{aligned}$$

$$\begin{aligned} \Delta\text{kWh (remaining seventeen years)} &= ((138 - 42) * 4,303) / 1000 \\ &= 413.2 \text{ kWh / year} \end{aligned}$$

Therefore, a midlife adjustment of 58.9% (413.2/701.4) would be applied after 3 years.

**SUMMER COINCIDENT PEAK DEMAND SAVINGS**

$$\Delta\text{kW} = (W_{\text{base}} - W_{\text{eff}}) / 1000 * \text{CF}$$

Where:

- CF = Summer Peak Coincidence Factor for measure
- = 0 for Standard operation
- = 1 for 8766 lighting

**FOSSIL FUEL SAVINGS**

N/A

**WATER AND OTHER NON-ENERGY IMPACT DESCRIPTIONS AND CALCULATION**

N/A

**DEEMED O&M COST ADJUSTMENT CALCULATION**

For EREP: to calculate an O&M adjustment, in addition to the deferred HPS replacement after 3 years, assume one additional HPS replacement lamp costing \$44 in year nine and year fifteen for standard operation or every 2.7 years for 8,766 hour lighting.<sup>1342</sup>

For TOS: Assume one additional HPS replacement costing \$44 every 6 years for standard operation or every 2.7 years for 8,766 hour lighting.

<sup>1342</sup> Assumes a rated life of the High Pressure Sodium lamp of 24,000 hours. High Pressure Sodium replacement cost (lamp and labor) was provided by ComEd based on their composite maintenance rate.

**MEASURE CODE: CI-LTG-STRT-V04-230101**

**REVIEW DEADLINE: 1/1/2025**

## 4.5.17 Exterior Photocell Repair

### DESCRIPTION

This measure characterizes the repair of a photocell on an existing exterior light. A photocell is designed to switch exterior lights off during daylight hours, but if broken the fixtures may remain on 8760 hours.

This measure was developed to be applicable to the following program types: RF.  
If applied to other program types, the measure savings should be verified.

### DEFINITION OF EFFICIENT EQUIPMENT

The efficient condition is an exterior light with a repaired or replaced photocell. The specifications and location of exterior lighting fixtures must be verified.

### DEFINITION OF BASELINE EQUIPMENT

The baseline condition is an exterior light with a broken photocell.

### DEEMED LIFETIME OF EFFICIENT EQUIPMENT

The assumed measure life is 2 years.<sup>1343</sup>

### DEEMED MEASURE COST

The deemed measure cost is \$65.52 per lighting sensor.<sup>1344</sup>

### LOADSHAPE

Loadshape C19 - Industrial Outdoor Lighting  
Loadshape C20 - Commercial Outdoor Lighting

### COINCIDENCE FACTOR

The summer peak coincidence factor for this measure is assumed to be 1.0. The savings for this measure will be throughout the daytime hours.

---



---

### Algorithm

---

### CALCULATION OF ENERGY SAVINGS

#### ELECTRIC ENERGY SAVINGS

$$\Delta kWh = (\text{Watts}_{\text{fixture}}/1000) * (\text{HOU}_{\text{PRE}} - \text{HOU}_{\text{POST}})$$

Where:

Watts<sub>fixture</sub> = Input wattage of exterior lighting fixture(s) controlled by photocell

HOU<sub>PRE</sub> = Fixture Annual Operating Hours before Photocell repair/replacement  
= 8,766 hours<sup>1345</sup>

---

<sup>1343</sup> Estimated remaining life of an exterior lamp running 8760 hours.

<sup>1344</sup> Wisconsin Focus on Energy TRM 2017 based on historical project data cost of 643 units over 31 projects from 2014 to 2018.

<sup>1345</sup> Exterior lighting with broken photocells are typically identified by visual inspection during the daytime and it is assumed that exterior lighting that is found to be on during daylight hours is on during *all* day and night hours.

$HOU_{POST}$  = Fixture Annual Operating Hours with Photocell repaired / replaced  
= 4,303 hours<sup>1346</sup>

**SUMMER COINCIDENT PEAK DEMAND SAVINGS**

$$\Delta kW = \Delta kWh / (HOU_{PRE} - HOU_{POST}) * CF$$

Where:

CF = Summer Peak Coincidence Factor for measure  
= 1<sup>1347</sup>

**FOSSIL FUEL SAVINGS**

N/A

**WATER AND OTHER NON-ENERGY IMPACT DESCRIPTIONS AND CALCULATION**

N/A

**DEEMED O&M COST ADJUSTMENT CALCULATION**

N/A

**MEASURE CODE: CI-LTG-PHRP-V01-210101**

**REVIEW DEADLINE: 1/1/2025**

---

<sup>1346</sup> Assumption for Dusk to Dawn as provided in Section 4.5.

<sup>1347</sup> The savings for this measure will be throughout the daytime hours when the repaired photocell turns lighting off.

## 4.5.18 Ultra-Efficient LED Lighting

### DESCRIPTION

This characterization provides savings assumptions for variety of ultra-efficient LED screw-based lamps including Omnidirectional (e.g., A-Type lamps), Decorative (e.g., Globes and Torpedoes) and Directional (PAR Lamps, Reflectors, MR16).

If the implementation strategy does not allow for the installation location to be known, for Residential targeted programs (e.g., an upstream retail program), a deemed split of 97% Residential and 3% Commercial assumptions should be used,<sup>1348</sup> and for Commercial targeted programs a deemed split of 97% Commercial and 3% Residential for non-linear LED Bulbs and 100% Commercial and 0% Residential for LED Fixtures and TLEDs should be used.<sup>1349</sup>

Income Qualified Programs should not use this measure, but should continue to follow the dedicated guidance found in TRM section 4.5.4 through 2025.

This measure was developed to be applicable to the following program types: TOS. If applied to other program types, the measure savings should be verified.

### DEFINITION OF EFFICIENT EQUIPMENT

In order for this characterization to apply, new lamps must exceed efficiency specifications defined in the “Standard-Efficiency LED Baseline Wattage” tables below. Consult the tables to find the *maximum* wattage that can be considered ultra-efficient for each bulb type.

Actual lamp wattages of the efficient equipment should be used to determine savings.

### DEFINITION OF BASELINE EQUIPMENT

This TRM assumes that as of 6/30/2023, non-income qualified participants no longer have access to bulbs that do not meet the efficacy requirement defined by an EISA backstop provision. That provision effectively ensures that all lamps available in the market are at minimum an LED (no incandescent or compact fluorescent products). Therefore, lamp wattages that were historically considered efficient have now become the baseline to compare against emerging ultra-efficient options. See “Standard-Efficiency LED Baseline Wattage” tables below for specific baseline wattages by lamp type and lumen output.

### DEEMED LIFETIME OF EFFICIENT EQUIPMENT

The lifetime for screw-based lamps is calculated as the rated lifetime of the product (actual if available, otherwise assume 20,000 hours for Omnidirectional, 17,000 hours for decorative and 25,000 for directional lamps based on average rated life of lamps on the ENERGY STAR Qualified Products list (accessed 6/16/2020)) divided by the reported operating hours, capped at 10 years.<sup>1350</sup>

---

<sup>1348</sup> RES v C&I split is based on a weighted (by sales volume) average of ComEd PY8, PY9 and CY2018 and Ameren PY8 in store intercept survey results. See ‘RESvCI Split\_2019.xlsx.’

<sup>1349</sup> Based on ComEd’s Instant Discounts program CY2018, CY2019 and CY2020 (Rounds 1 and 2) Purchaser Survey analysis. See ComEd Instant Discounts Enduser Survey TRM Updates.xlsx. For Residential installations, hours of use assumptions from ‘5.5.6 LED Downlights’ should be used for LED fixtures and ‘5.5.8 LED Screw Based Omnidirectional Bulbs’ should be used for LED bulbs.



**DEEMED MEASURE COST**

The actual ultra-efficient LED lamp cost should be used. For incremental cost, assume a baseline cost according to the following table<sup>1351</sup>:

Bulb Type	Standard LED Baseline Cost
<b>Omnidirectional</b>	\$2.70
<b>Directional</b>	\$5.18
<b>Decorative and Globe</b>	\$3.40

**LOADSHAPE**

- Loadshape C06 - Commercial Indoor Lighting
- Loadshape C07 - Grocery/Conv. Store Indoor Lighting
- Loadshape C08 - Hospital Indoor Lighting
- Loadshape C09 - Office Indoor Lighting
- Loadshape C10 - Restaurant Indoor Lighting
- Loadshape C11 - Retail Indoor Lighting
- Loadshape C12 - Warehouse Indoor Lighting
- Loadshape C13 - K-12 School Indoor Lighting
- Loadshape C14 - Indust. 1-shift (8/5) (e.g., comp. air, lights)
- Loadshape C15 - Indust. 2-shift (16/5) (e.g., comp. air, lights)
- Loadshape C16 - Indust. 3-shift (24/5) (e.g., comp. air, lights)
- Loadshape C17 - Indust. 4-shift (24/7) (e.g., comp. air, lights)
- Loadshape C18 - Industrial Indoor Lighting
- Loadshape C19 - Industrial Outdoor Lighting
- Loadshape C20 - Commercial Outdoor Lighting
- Loadshape C60 – Non-Residential Agriculture Lighting – 6 Hours
- Loadshape C61 – Non-Residential Agriculture Lighting – 8 Hours
- Loadshape C62 – Non-Residential Agriculture Lighting – 12 Hours
- Loadshape C63 – Non-Residential Dairy Long Day Lighting – 17 Hours
- Loadshape C64 – Non-Residential Agriculture Lighting – 24 Hours

**COINCIDENCE FACTOR**

The summer peak coincidence factor for this measure is dependent on the location type. Values are provided for each building type in the reference section below.

<sup>1351</sup> Baseline and LED lamp costs are based on field data collected by CLEAResult and provided by ComEd. See ComEd Pricing Projections 06302016.xlsx for analysis. Given LED prices are expected to continue declining assumed costs should be reassessed on an annual basis and replaced with IL specific LED program information when available.

**Algorithm**

**CALCULATION OF ENERGY SAVINGS**

**ELECTRIC ENERGY SAVINGS**

$$\Delta kWh = ((Watts_{base} - Watts_{EE}) / 1000) * Hours * WHF_e * ISR$$

Where:

Watts<sub>EE</sub> = Actual wattage of LED purchased / installed must be used.

Watts<sub>base</sub> = Assumed wattage of standard efficiency LED baseline bulb. Reference the appropriate “Standard-Efficiency LED Baseline Wattage” table below.

**Standard-Efficiency LED Baseline Wattage: Omnidirectional Lamps**

Minimum Lumens	Maximum Lumens	Standard LED Baseline Wattage (WattsBase)
120	399	4.0
400	749	6.6
750	899	9.6
900	1,399	13.1
1,400	1,999	16.0
2,000	2,999	21.8
3,000	3,299	28.9

**Standard-Efficiency LED Baseline Wattage: Decorative Lamps**

Bulb Type	Minimum Lumens	Maximum Lumens	Standard LED Baseline Wattage (WattsBase)
Omni-Directional 3-Way	1,100	1,999	14.7
	2,000	2,700	22.6
Globe (medium and intermediate bases less than 750 lumens)	310	349	3.0
	350	499	4.7
	500	574	5.7
	575	649	6.5
	650	1,000	8.2
Globe (candelabra bases less than 1050 lumens)	310	349	3.5
	350	499	4.4
	500	574	5.5
Decorative (Shapes B, BA, C, CA, DC, F, G, medium and intermediate bases less than 750 lumens)	310	499	4.3
	500	800	5.8

Bulb Type	Minimum Lumens	Maximum Lumens	Standard LED Baseline Wattage (Watts <sub>Base</sub> )
Decorative (Shapes B, BA, C, CA, DC, F, G, T candelabra bases less than 1050 lumens)	310	499	4.2
	500	650	5.5
Decorative (Shape ST)	310	499	6.5
	500	999	8.8
	1000	1500	10.0
Decorative (Shape S)	310	340	2.25

**Standard-Efficiency LED Baseline Wattage: Directional Lamps**

Bulb Type	Minimum Lumens	Maximum Lumens	Standard LED Baseline Wattage (Watts <sub>Base</sub> )
Reflector lamp types with medium screw bases (PAR20, PAR30(S,L), PAR38, R40, etc.) w/ diameter >2.25"	400	649	7.0
	650	899	10.7
	900	1,049	13.9
	1,050	1,199	13.8
	1,200	1,499	15.9
	1,500	1,999	18.9
	2,000	3,299	27.3
Reflector lamp types with medium screw bases (PAR16, R14, R16, etc.) w/ diameter <2.25"	310	374	4.6
	375	600	6.4
BR30, BR40, or ER40	650	949	9.3
	950	1,099	12.7
	1,100	1,399	14.4
	1,400	1,600	16.6
	1,601	1,800	22.2
R20	450	524	6.0
	525	750	7.1
MR16	310	324	3.8
	325	369	4.8
	370	400	4.9

**Standard-Efficiency LED Baseline Wattage Table: Additional EISA non-exempt bulb types**

Bulb Type	Minimum Lumens	Maximum Lumens	Standard LED Baseline Wattage (Watts <sub>Base</sub> )
Dimmable Twist, Globe (less than 5" in diameter and > 749 lumens), candle (shapes B, BA, CA > 749 lumens), Candelabra Base Lamps (>1049 lumens), Intermediate Base Lamps (>749 lumens)	310	399	4.0
	400	749	6.6
	750	899	9.6
	900	1,399	13.1
	1,400	1,999	16.0

**Hours** = Average hours of use per year are provided in the Reference Table in Section 4.5 for each building type. If unknown, use the Miscellaneous value.

**WHFe** = Waste heat factor for energy to account for cooling energy savings from efficient lighting are provided below for each building type in the Reference Table in Section 4.5. If unknown, use the Miscellaneous value.

**ISR** = In Service Rate -the percentage of units rebated that actually get installed.  
 =100% if application form completed with sign off that equipment is not placed into storage.<sup>1352</sup> If sign off form not completed, assume the following ISR assumptions, if program survey data is not available:

Type	1st year In Service Rate (ISR) <sup>1353</sup>
LED Bulbs	97.9% <sup>1354</sup>
Efficiency Kits	92.9% <sup>1355</sup>

**HEATING PENALTY**

If electrically heated building:

$$\Delta kWh_{\text{heatingpenalty}}^{1356} = (((\text{WattsBase}-\text{WattsEE})/1000) * \text{ISR} * \text{Hours} * -\text{fKWh})$$

<sup>1352</sup> Illinois evaluation of PY1 through PY3 has not found that fixtures or lamps placed into storage to be a significant enough issue to warrant including an “In-Service Rate” when commercial customers complete an application form.

<sup>1353</sup> In Service Rates now represent the lifetime In Service Rates with the second and third year installations discounted by the Real Discount Rate of 0.46%. Lifetime ISR assumptions for efficiency kits are based upon Residential direct mailed kits. For all other programs the 98% Lifetime ISR assumption is based upon the standard CFL measure in the absence of any better reference. This value is based upon review of two evaluations:

‘Nexus Market Research, RLW Analytics and GDS Associates study; ‘New England Residential Lighting Markdown Impact Evaluation, January 20, 2009’ and ‘KEMA Inc, Feb 2010, Final Evaluation Report:, Upstream Lighting Program, Volume 1.’ This implies that only 2% of bulbs purchased are never installed. The second and third year installations are based upon Ameren analysis of the Californian KEMA study showing that 54% of future installs occur in year 2 and 46% in year 3.

<sup>1354</sup> Based on ComEd’s Instant Discounts program CY2019 and CY2020 (Rounds 1 and 2) Purchaser Survey analysis. See ComEd Instant Discounts Enduser Survey TRM Updates.xlsx

<sup>1355</sup> First year ISR is average ISR from CY2018, CY2019 and CY2020 ComEd Small Business Kit participant installation surveys. Please see file “SB Kits Survey Analysis TRMv10 Support.xlsx”

<sup>1356</sup>Negative value because this is an increase in heating consumption due to the efficient lighting.

Where:

IFkWh = Lighting-HVAC Interaction Factor for electric heating impacts; this factor represents the increased electric space heating requirements due to the reduction of waste heat rejected by the efficient lighting. Values are provided in the Reference Table in Section 4.5. If unknown, use the Miscellaneous value.

#### **SUMMER COINCIDENT PEAK DEMAND SAVINGS**

$$\Delta kW = ((\text{Watts}_{\text{base}} - \text{Watts}_{\text{EE}}) / 1000) * \text{ISR} * \text{WHF}_d * \text{CF}$$

Where:

WHF<sub>d</sub> = Waste Heat Factor for Demand to account for cooling savings from efficient lighting in cooled buildings is provided in Reference Table in Section 4.5. If unknown, use the Miscellaneous value.

CF = Summer Peak Coincidence Factor for measure is provided in the Reference Table in Section 4.5. If unknown, use the Miscellaneous value.

#### **FOSSIL FUEL SAVINGS**

Heating Penalty if fossil fuel heated building (or if heating fuel is unknown):

$$\Delta \text{Therms} = ((\text{Watts}_{\text{Base}} - \text{Watts}_{\text{EE}}) / 1000) * \text{ISR} * \text{Hours} * \text{IFTherms}$$

Where:

IFTherms = Lighting-HVAC Integration Factor for gas heating impacts; this factor represents the increased gas space heating requirements due to the reduction of waste heat rejected by the efficient lighting. Values are provided in the Reference Table in Section 4.5. If unknown, use the Miscellaneous value.

#### **WATER AND OTHER NON-ENERGY IMPACT DESCRIPTIONS AND CALCULATION**

N/A

#### **DEEMED O&M COST ADJUSTMENT CALCULATION**

N/A

**MEASURE CODE: CI-LTG-ULED-V01-240101**

**REVIEW DEADLINE: 1/1/2026**

## 4.6.Refrigeration End Use

### 4.6.1 Automatic Door Closer for Walk-In Coolers and Freezers

#### DESCRIPTION

This measure is for installing an auto-closer to the main insulated opaque door(s) of a walk-in cooler or freezer. The auto-closer must firmly close the door when it is within 1 inch of full closure.

This measure was developed to be applicable to the following program types: RF.

If applied to other program types, the measure savings should be verified.

#### DEFINITION OF EFFICIENT EQUIPMENT

This measure consists of the installation of an automatic, hydraulic-type door closer on main walk-in cooler or freezer doors. These closers save energy by reducing the infiltration of warm outside air into the refrigeration itself.

#### DEFINITION OF BASELINE EQUIPMENT

In order for this characterization to apply, the baseline condition is assumed to be a walk in cooler or freezer without an automatic closure.

#### DEEMED LIFETIME OF EFFICIENT EQUIPMENT

The deemed measure life is 8 years.<sup>1357</sup>

#### DEEMED MEASURE COST

The deemed incremental measure cost, which includes labor costs, is \$502 for a walk-in cooler or freezer.<sup>1358</sup>

#### LOADSHAPE

Loadshape C22 - Commercial Refrigeration

#### COINCIDENCE FACTOR

The measure has deemed kW savings therefore a coincidence factor does not apply.

---



---

#### Algorithm

---



---

#### CALCULATION OF SAVINGS

#### ELECTRIC ENERGY SAVINGS

Savings calculations are based on values from through SCE Workpaper SWCR005 – Auto-Closers for Refrigerated Storage Door. Savings are averaged across all California climate zones and vintages.<sup>1359</sup>

Annual Savings	kWh
Walk in Cooler	2,399
Walk in Freezer	6,949

<sup>1357</sup> Measure life estimate is sourced from California DEER Ex-Ante Support Table – 2020, Auto-Closer for Walk-In Cooler/Freezer Doors (GrocWIKIn-DrClSr). For more detail, please see: "SupportTable\_EUL2020.xlsx".

<sup>1358</sup> Commercial Refrigeration: Auto-Closer for Refrigerated Storage Door (SWCR005-02), California eTRM, November 16, 2020

<sup>1359</sup> Commercial Refrigeration: Auto-Closer for Refrigerated Storage Door (SWCR005-02), California eTRM, November 16, 2020. Energy savings are per cooler/freezer and represent an average of the modeled savings across all California climate zones.

**SUMMER COINCIDENT PEAK DEMAND SAVINGS**

Annual Savings	kW
Walk in Cooler	0.621
Walk in Freezer	1.300

**FOSSIL FUEL SAVINGS**

Natural gas savings are attributable to automatic door closers for refrigerated storage spaces. If the site is heated with natural gas as the primary fuel type, the following deemed fossil fuel savings can be claimed:<sup>1360</sup>

Annual Savings	Therms
Walk in Cooler	0.183
Walk in Freezer	0.516

**WATER IMPACT DESCRIPTIONS AND CALCULATION**

N/A

**DEEMED O&M COST ADJUSTMENT CALCULATION**

N/A

**MEASURE CODE: CI-RFG-ATDC-V03-230101**

**REVIEW DEADLINE: 1/1/2028**

---

<sup>1360</sup> Commercial Refrigeration: Auto-Closer for Refrigerated Storage Door (SWCR005-02), California eTRM, November 16, 2020

## 4.6.2 Beverage and Snack Machine Controls

### DESCRIPTION

This measure relates to the installation of new controls on refrigerated beverage vending machines, non-refrigerated snack vending machines, and glass front refrigerated coolers. Controls can significantly reduce the energy consumption of vending machine and refrigeration systems. Qualifying controls must power down these systems during periods of inactivity but, in the case of refrigerated machines, must always maintain a cool product that meets customer expectations. This measure relates to the installation of a new control on a new or existing unit. This measure should **not** be applied to ENERGY STAR qualified vending machines, as they already have built-in controls.

Vending machine categories are as defined<sup>1361</sup> below:

- Refrigerated Beverage Vending Machine: A commercial refrigerator that cools bottled and/or canned beverages and dispenses the bottled and/or canned beverages on payment. Bottled or canned beverages means a beverage in a sealed container.
  - Class A Machine: A refrigerated bottled and/or canned beverage vending machine that is not a combination vending machine and in which 25 percent or more of the surface area on the front side of the beverage vending machine is transparent.
  - Class B Machine: Any refrigerated bottled and/or canned beverage vending machine not considered to be Class A, and is not a combination vending machine.
- Combination Vending Machine: A bottled and/or canned beverage vending machine containing two or more compartments separated by a solid partition, that may or may not share a product delivery chute, in which at least one compartment is designed to be refrigerated, as demonstrated by the presence of temperature controls, and at least one compartment is not.
  - Combination A: Combination vending machine where 25 percent or more of the surface area on the front side of the beverage vending machine is transparent.
  - Combination B: Combination vending machine that is not considered to be Combination A.

This measure was developed to be applicable to the following program types: RF.

If applied to other program types, the measure savings should be verified.

### DEFINITION OF EFFICIENT EQUIPMENT

In order for this characterization to apply, the efficient equipment is assumed to be a standard efficiency refrigerated beverage vending machine, non-refrigerated snack vending machine, or glass front refrigerated cooler with a control system capable of powering down lighting and refrigeration systems during periods of inactivity.

### DEFINITION OF BASELINE EQUIPMENT

In order for this characterization to apply, the baseline equipment is assumed to be a standard efficiency refrigerated beverage vending machine, non-refrigerated snack vending machine, or glass front refrigerated cooler without a control system capable of powering down lighting and refrigeration systems during periods of inactivity.

### DEEMED LIFETIME OF EFFICIENT EQUIPMENT

The expected measure life is assumed to be 5 years.<sup>1362</sup>

---

<sup>1361</sup> Code of Federal Regulations at 10 CFR 431. Subpart Q §431.296.

<sup>1362</sup> Measure Life Study, prepared for the Massachusetts Joint Utilities, Energy & Resource Solutions, November 2005.



**DEEMED MEASURE COST**

The actual measure installation cost should be used (including material and labor), but the following control costs<sup>1363</sup> can be assumed for analysis purposes:

- Refrigerated Vending Machine and Glass Front Cooler: \$245
- Non-Refrigerated Vending Machine: \$233

**LOADSHAPE**

Loadshape C52 - Beverage and Snack Machine Controls

**COINCIDENCE FACTOR**

The summer peak coincidence factor for this measure is assumed to be 0.<sup>1364</sup>

---

**Algorithm**

---

**CALCULATION OF SAVINGS**

**ELECTRIC ENERGY SAVINGS**

$$\Delta kWh = \Delta kWh_{\text{Lighting}} + \Delta kWh_{\text{Ref BMC}}$$

$$\Delta kWh_{\text{Lighting}} = \frac{((8760 - \text{OccHours}) * W_{\text{Bulb}})}{1000}$$

$$\Delta kWh_{\text{Ref BMC}} = \text{MDEC} * (\text{SleepHours} / 24) * \text{Days}$$

Where:

- OccHours = Average Annual Hours facility is occupied<sup>1365</sup>  
= Actual, if unknown<sup>1366</sup> assume 3,379 hrs
- W<sub>Bulb</sub> = Wattage of bulb in Refrigerated Beverage Vending Machine.  
= Actual. If unknown use 56.4 W<sup>1367</sup> for fluorescent T8 bulbs<sup>1368</sup> and 31.6 W<sup>1369</sup> for TLEDs.

---

<sup>1363</sup> Measure Data and Specifications for the "Vending and Beverage Merchandise Controller", from the California eTRM, last updated 12/27/2018. Measure cost + Labor cost. The refrigerated machine was an average of several types (Double, single and triple doors). Please see file: SWAP011-01 MeasureDataSpec - Vending and Beverage Merchandise Controller r0.6.xlsm

<sup>1364</sup> Assumed that the peak period is coincident with periods of high traffic diminishing the demand reduction potential of occupancy based controls.

<sup>1365</sup> Occupied hours of Use per IL TRM Section 4.5 Lighting, Fixture Annual Operating Hours.

<sup>1366</sup> If location is known, but hours are unknown, see IL TRM Section 4.5 Lighting, for list of various locations and Annual Hours.

<sup>1367</sup> See 3.4.5 LED Fixtures for the F32T8 Standard Lamp - 4 foot x 2 bulbs.

<sup>1368</sup> Per Houghton, D. 1996. "Refrigerated Vending Machines - Overlooked Devices Hold Opportunities for Efficiency, New Services." E Source Tech Update, TU-96-7, the typical backlit display for a refrigerated beverage vending machine consists of two five-foot linear fluorescent lamps." (PGE, SWAP011-01 Vending and Beverage Merchandise Controller measure, MeasureDataSpec file)

<sup>1369</sup> See 3.4.5 LED Fixtures for the TLED Lamp x 2 bulbs.

MDEC = Maximum Daily Energy Consumption per Federal regulations<sup>1370</sup>. Refrigerated Volume of 21 (ft<sup>3</sup>) used in the calculations<sup>1371</sup>. If unknown, assume Class B, post-2019<sup>1372</sup>:

Class	Vintage	EQN	MDEC (kWh/d)
A	post-2019	$0.052 * V + 2.43$	3.52
B		$0.052 * V + 2.20$	3.29
Combination A		$0.086 * V + 2.66$	4.47
Combination B		$0.111 * V + 2.04$	4.37
A	pre-2019	$0.055 * V + 2.56$	3.72
B		$0.073 * V + 3.16$	4.69

SleepHours = Maximum hours of sleep mode per day.

$$= 4 \text{ hrs}^{1373}$$

Days = Operating Days/yr.

$$= 365$$

**For example**, adding controls to a Class B post-2019 Vintage refrigerated beverage vending machine in an unknown location:

$$\Delta kWh = \Delta kWh_{\text{lighting}} + \Delta kWh_{\text{Ref BMC}}$$

$$\begin{aligned} \Delta kWh_{\text{lighting}} &= (8760 - \text{OccHours}) * W_{\text{Bulb}} \\ &= ((8760 - 3,379) * 72 \text{ W}) / 1,000 \\ &= 387 \text{ kWh/yr} \end{aligned}$$

$$\begin{aligned} \Delta kWh_{\text{Ref BMC}} &= \text{MDEC} * \text{SleepHours} / 24 * \text{Days} \\ &= 3.29 * 4 / 24 * 365 \\ &= 200 \text{ kWh/yr} \end{aligned}$$

$$\Delta kWh = 587 \text{ kWh/yr}$$

**SUMMER COINCIDENT PEAK DEMAND SAVINGS**

N/A

**FOSSIL FUEL SAVINGS**

N/A

**WATER IMPACT DESCRIPTIONS AND CALCULATION**

N/A

<sup>1370</sup> 10 CFR 431. Subpart Q §431.296

<sup>1371</sup> U.S. Department of Energy (DOE), Office of Energy Efficiency and Renewable Energy, Federal Energy Management Program. (n.d.) "Purchasing Energy-Efficient Refrigerated Beverage Vending Machines." Updated January 2020.

<sup>1372</sup> Those standards are the most stringent and therefore savings would be conservative.

<sup>1373</sup> Itron, Inc. 2005. 2004-2005 Database for Energy Efficiency Resources (DEER) Update Study - Final Report. Prepared for the California Public Utilities Commission. Pg 3-22.

**DEEMED O&M COST ADJUSTMENT CALCULATION**

N/A

**MEASURE CODE: CI-RFG-BEVM-V04-220101**

**REVIEW DEADLINE: 1/1/2025**

### 4.6.3 Door Heater Controls for Cooler or Freezer

#### DESCRIPTION

By installing a control device to turn off door heaters when there is little or no risk of condensation, one can realize significant energy savings. There are two commercially available control strategies that achieve “on-off” control of door heaters based on either (1) the relative humidity of the air in the store, or (2) the “conductivity” of the door (which drops when condensation appears). In the first strategy, the system activates your door heaters when the relative humidity in your store rises above a specific setpoint, and turns them off when the relative humidity falls below that setpoint. In the second strategy, the sensor activates the door heaters when the door conductivity falls below a certain setpoint, and turns them off when the conductivity rises above that setpoint.

This measure was developed to be applicable to the following program types: RF.

If applied to other program types, the measure savings should be verified.

#### DEFINITION OF EFFICIENT EQUIPMENT

In order for this characterization to apply, the efficient equipment is assumed to be a door heater control on a commercial glass door cooler or refrigerator utilizing humidity or conductivity control.

#### DEFINITION OF BASELINE EQUIPMENT

In order for this characterization to apply, the baseline condition is assumed to be a commercial glass door cooler or refrigerator with a standard heated door with no controls installed.

#### DEEMED LIFETIME OF EFFICIENT EQUIPMENT

The expected measure life is assumed to be 10 years.<sup>1374</sup>

#### DEEMED MEASURE COST

The incremental capital cost, including labor costs, for a refrigeration door heater control, regardless of the control strategy, on a per door basis is \$79.50 per cooler door and \$90.77 per freezer door.<sup>1375</sup>

#### LOADSHAPE

Loadshape C51 - Door Heater Control

#### COINCIDENCE FACTOR<sup>1376</sup>

The summer peak coincidence factor for this measure is assumed to be 44%.<sup>1377</sup>

---



---

#### Algorithm

---

#### CALCULATION OF SAVINGS

##### ELECTRIC ENERGY SAVINGS

$$\Delta\text{kWH} = \text{kWbase} * \text{NUMdoors} * \text{ESF} * \text{BF} * 8766$$

---

<sup>1374</sup> As recommended in Navigant ‘ComEd Effective Useful Life Research Report’, May 2018.

<sup>1375</sup> Door heater control unit costs are based on historical cost data, specific to the state of Illinois, collected by Ameren. See reference “Door Heater Costs AIC.xlsx” for more detail.

<sup>1376</sup> Source partial list from DEER 2008.

<sup>1377</sup> The summer peak coincidence factor is sourced from; Cadmus, “Commercial Refrigeration Loadshape Project Final Report”, Northeast Energy Efficiency Partnership, Regional Evaluation, Measurement, and Verification Forum, Lexington, MA, 2015 (table 39). The coincidence factor is based on the run-time profile of anti-sweat door heater controls, for all control types, for summer peak hours, and represents an average of the monitored reduced run time between heaters with and without controls.

Where:

- kWbase = connected load kW for typical reach-in refrigerator or freezer door and frame with a heater.
- coolers.<sup>1378</sup> = If actual kWbase is unknown, assume 0.230 kW for freezers and 0.066 kW for coolers.
- NUMdoors = number of reach-in refrigerator or freezer doors controlled by sensor  
= Actual installed
- ESF = Energy Savings Factor; represents the percentage of hours annually that the door heater is powered off due to the controls.  
= 45% for all control types <sup>1379</sup>
- BF = Bonus Factor; represents the increased savings due to reduction in cooling load inside the cases, and the increase in cooling load in the building space to cool the additional heat generated by the door heaters. <sup>1380</sup>

Definition	Representative Evaporator Temperature Range, °F <sup>1381</sup>	Typical Uses	BF
Low	-35 to 0	Freezers for times such as frozen pizza, ice cream, etc.	1.50
Medium	0 – 20	Coolers for items such as meat, milk, dairy, etc	1.30
High	20 – 45	Coolers for items such as floral, produce and meat preparation rooms	1.30

8766 = annual hours of operation

**SUMMER COINCIDENT PEAK DEMAND SAVINGS**

$$\Delta kW = (\Delta kWh / 8766) * CF$$

Where:

- CF = Summer Coincident Factor for the measure  
= 0.44<sup>1382</sup>

<sup>1378</sup> Wattages per door derived from NEEP Refrigeration Loadshape Report. The Cadmus Group, Commercial Refrigeration Loadshape Project Final Report, Northeast Energy Efficiency Partnerships, Regional Evaluation, Measurement, and Verification Forum, Lexington, MA 2015 (pg. 57). For more detail, see reference file: IL TRM\_Door Heater Control\_Analysis\_Jun 2021.xlsx

<sup>1379</sup> Difference in effective runtime of an uncontrolled heater and all control style heater controls. Anti-sweat door heater control reduced run time. The Cadmus Group, Commercial Refrigeration Loadshape Project Final Report, Northeast Energy Efficiency Partnerships, Regional Evaluation, Measurement, and Verification Forum, Lexington, MA 2015. Page 69, Section 4.1.4, Table 37.

<sup>1380</sup> Cooler and freezer bonus factors are from NEEP Refrigeration Loadshape Report. The Cadmus Group, Commercial Refrigeration Loadshape Project Final Report, Northeast Energy Efficiency Partnerships, Regional Evaluation, Measurement, and Verification Forum, Lexington, MA 2015 (pg. 78)

<sup>1381</sup> Energy Efficiency Supermarket Refrigeration, Wisconsin Electric Power Company, July 23, 1993.

<sup>1382</sup> The summer peak coincidence factor is sourced from; Cadmus, “Commercial Refrigeration Loadshape Project Final Report”, Northeast Energy Efficiency Partnership, Regional Evaluation, Measurement, and Verification Forum, Lexington, MA, 2015 (table 39). The coincidence factor is based on the run-time profile of anti-sweat door heater controls, for all control types, for summer peak hours, and represents an average of the monitored reduced run time between heaters with and without controls.

**FOSSIL FUEL SAVINGS**

N/A

**WATER IMPACT DESCRIPTIONS AND CALCULATION**

N/A

**DEEMED O&M COST ADJUSTMENT CALCULATION**

N/A

**MEASURE CODE: CI-RFG-DHCT-V04-220101**

**REVIEW DEADLINE: 1/1/2027**

#### 4.6.4 Electronically Commutated Motors (ECM) for Walk-in and Reach-in Coolers / Freezers

##### DESCRIPTION

This measure is applicable to the replacement of an existing, uncontrolled, and continuously operating standard-efficiency shaded-pole evaporator fan motor in refrigerated display cases or fan coil in walk-ins.

This measure achieves savings by installing a more efficient motor, the result of which produces less waste heat that the cooling system must reject.

If applicable, savings from this measure may be claimed in combination with measure 4.6.6 Evaporator Fan Control for Electrically Commutated Motors.

This measure was developed to be applicable to the following program types: RF.

If applied to other program types, the measure savings should be verified.

##### DEFINITION OF EFFICIENT EQUIPMENT

This measure applies to the replacement of an existing standard-efficiency shaded-pole evaporator fan motor in refrigerated display cases or fan coil in walk-ins. The replacement unit must be an electronically commutated motor (ECM) with a minimum efficiency of 66%. If controls are added as part of the motor upgrade to reduce annual run time, additional savings may potentially be claimed using measure 4.6.6 Evaporator Fan Control.

##### DEFINITION OF BASELINE EQUIPMENT

The baseline is the existing shaded-pole motor(s) with no fan control operating 8760 hours continuously in a refrigerated display case or fan coil unit of a walk-in cooling unit.

##### DEEMED LIFETIME OF EFFICIENT EQUIPMENT

The expected measure life is assumed to be 15 years.<sup>1383</sup>

##### DEEMED MEASURE COST

The measure cost is assumed to be \$230.94 (EC Motor equipment) plus \$73.65 (EC Motor labor) = \$304.59 per motor for a walk in cooler and walk in freezer.<sup>1384</sup>

##### LOADSHAPE

Loadshape C53 - Flat

##### COINCIDENCE FACTOR

The peak kW coincidence factor is 100%.

---

---

#### Algorithm

---

---

##### CALCULATION OF SAVINGS

##### ELECTRIC ENERGY SAVINGS

$$\Delta\text{kWh} = \text{Savings per motor} * \text{motors}$$

Where:

Savings per motor = based on the motor rating of the ECM motor:

---

<sup>1383</sup> DEER, Work Paper PGE3PREF126 ECM for Walk-In Evaporator with Fan Controller Revision # 2

<sup>1384</sup> DEER, Work Paper PGE3PREF126 ECM for Walk-In Evaporator with Fan Controller Revision # 2

Evaporator Fan Motor Rating (of ECM)	Annual kWh Savings/motor
16W	652
1/15 - 1/20HP	1,586
1/5HP	2,320
1/3HP	3,380
1/2HP	4,481
3/4HP	5,293

= If unknown, assume 1/15 HP, therefore 1,586 kWh saved / motor<sup>1385</sup>

motors = number of fan motors replaced

**SUMMER COINCIDENT PEAK DEMAND SAVINGS**

$$\Delta kW = \Delta kWh / \text{Hours} * CF * \text{motors}$$

Where:

$\Delta kWh$  = Gross customer annual kWh savings for the measure, as listed above  
 = If unknown, assume 1,586 kWh<sup>1386</sup>

Hours = Full Load hours per year  
 = 8760

CF = Summer Peak Coincident Factor  
 = 1.0

Other variables as defined above.

The following table provides the resulting kW savings (per motor), if unknown assume 0.181 kW saved / motor:<sup>1387</sup>

Evaporator Fan Motor Rating (of ECM)	Peak kW Savings/motor
16W	0.074
1/15 - 1/20HP	0.181
1/5HP	0.265
1/3HP	0.386
1/2HP	0.512
3/4HP	0.604

**FOSSIL FUEL SAVINGS**

N/A

**WATER IMPACT DESCRIPTIONS AND CALCULATION**

N/A

**DEEMED O&M COST ADJUSTMENT CALCULATION**

N/A

<sup>1385</sup> Default motor size for EC Evaporator was found to be ≤ 1/15 HP per the ComEd Standard Program data. See ECM Motor Size Supplement.xlsx.

<sup>1386</sup> Ibid.

<sup>1387</sup> Ibid.



**MEASURE CODE: CI-RFG-ECMF-V04-220101**

**REVIEW DEADLINE: 1/1/2025**

## 4.6.5 ENERGY STAR Refrigerated Beverage Vending Machine

### DESCRIPTION

ENERGY STAR qualified new and rebuilt vending machines incorporate more efficient compressors, fan motors, and lighting systems as well as low power mode option that allows the machine to be placed in low-energy lighting and/or low-energy refrigeration states during times of inactivity.

This measure was developed to be applicable to the following program types: TOS, NC .

If applied to other program types, the measure savings should be verified.

### DEFINITION OF EFFICIENT EQUIPMENT

The refrigerated vending machine can be new or rebuilt but must meet the ENERGY STAR specifications, as outlined below.<sup>1388</sup>

A. Refrigerated Beverage Vending Machine: A commercial refrigerator that cools bottled and/or canned beverages and dispenses the bottled and/or canned beverages on payment. Bottled or canned beverages means a beverage in a sealed container.

a. Class A Machine: A refrigerated bottled and/or canned beverage vending machine that is not a combination vending machine and in which 25 percent or more of the surface area on the front side of the beverage vending machine is transparent.

b. Class B Machine: Any refrigerated bottled and/or canned beverage vending machine not considered to be Class A, and is not a combination vending machine

B. Combination Vending Machine: A bottled and/or canned beverage vending machine containing two or more compartments separated by a solid partition, that may or may not share a product delivery chute, in which at least one compartment is designed to be refrigerated, as demonstrated by the presence of temperature controls, and at least one compartment is not.

a. Combination A Machine: A combination vending machine where 25 percent or more of the surface area on the front side of the beverage vending machine is transparent.

b. Combination B Machine: A combination vending machine that is not considered to be Combination A.

### DEFINITION OF BASELINE EQUIPMENT

The baseline vending machine is a standard unit.

### DEEMED LIFETIME OF EFFICIENT EQUIPMENT

The deemed lifetime of this measure is 14 years.<sup>1389</sup>

### DEEMED MEASURE COST

The incremental cost of this measure is \$500.<sup>1390</sup>

### LOADSHAPE

Loadshape C22 - Commercial Refrigeration

---

<sup>1388</sup> ENERGY STAR Program Requirements Specification for Refrigerated Beverage Vending Machines, Version 4.0

<sup>1389</sup> ENERGY STAR

<sup>1390</sup> ENERGY STAR

**COINCIDENCE FACTOR**

It is assumed that controls are only effective during off-peak hours and so have no peak-kW savings.

---

**Algorithm**

---

**CALCULATION OF SAVINGS**

**ELECTRIC ENERGY SAVINGS**

Using the ENERGY STAR MDEC Equations, as specified in the above paragraph and the Baseline Equipment DOE Standards,<sup>1391</sup> the theoretical energy savings are calculated as:

$$\Delta kWh = (MDEC_{Baseline} - MDEC_{Efficient}) * Days$$

Where:

- MDEC<sub>Baseline</sub> = Maximum Daily Energy Consumption calculated using the equation from the table below, specific for the baseline equipment class and the volume range
- MDEC<sub>Efficient</sub> = Maximum Daily Energy Consumption calculated using the equation from the table below, specific for the ENERGY STAR Specification 4.0 equipment class and the volume range
- Days = Days per year  
= Actual. If unknown, assume 365.

Maximum Daily Energy Consumption (MDEC) equations for Baseline Equipment and ENERGY STAR equipment compliant with ENERGY STAR Specification V4.0 are outline in the table below:

Product Class	Refrigerated Volume Range (ft <sup>3</sup> )	MDEC Equation (kWh/day) Federal Standard: Baseline Equipment	MDEC Equation (kWh/day) ENERGY STAR Specification V 4.0
Class A	11.5 - 38.5	0.052 * V + 2.43	0.04836 * V + 2.2599
Class B	21.8 - 30.5	0.052 * V + 2.20	0.04576 * V + 1.936
Combination A	9.7 - 16	0.086 * V + 2.66	0.07998 * V + 2.4738
Combination B	N/A	0.111 * V + 2.04	0.09768 * V + 1.7952

Where:

V = the refrigerated volume (ft<sup>3</sup>) of the refrigerated bottled or canned beverage vending machine, as specified in Appendix C.<sup>1392</sup>

**SUMMER COINCIDENT PEAK DEMAND SAVINGS**

N/A

**FOSSIL FUEL SAVINGS**

N/A

---

<sup>1391</sup> CFR Title 10: Energy. PART 431—ENERGY EFFICIENCY PROGRAM FOR CERTAIN COMMERCIAL AND INDUSTRIAL EQUIPMENT

<sup>1392</sup> Appendix C of the American National Standards Institute (ANSI)/ American Society of Heating, Refrigerating and Air-Conditioning Engineers (ASHRAE) Standard 32.1 - 2010, "Methods of Testing for Rating Vending Machines for Bottled, Canned or Other Sealed Beverages." For combination vending machines, the refrigerated volume does not include any non-refrigerated compartments.

**WATER IMPACT DESCRIPTIONS AND CALCULATION**

N/A

**DEEMED O&M COST ADJUSTMENT CALCULATION**

N/A

**MEASURE CODE: CI-RFG-ESVE- V04-210101**

**REVIEW DEADLINE: 1/1/2025**

## 4.6.6 Evaporator Fan Control for Electrically Commutated Motors

### DESCRIPTION

This measure is for the installation of controls for Electronically Commutated Motors in existing medium temperature walk-in coolers. The controller reduces airflow of the evaporator fans when there is no refrigerant flow.

This measure achieves savings by controlling the motor(s) to run at lower speeds (or shut off entirely) when there is no refrigerant flow, the result of which produces less waste heat that the cooling system must reject.

If eligible, this measure may be claimed in combination with 4.6.4 Electronically Commutated Motors (ECM) for Walk-in and Reach-in Coolers / Freezers.

This measure was developed to be applicable to the following program types: RF.

If applied to other program types, the measure savings should be verified.

### DEFINITION OF EFFICIENT EQUIPMENT

The measure must control a minimum of 1/20 HP where fans operate continuously at full speed. The measure also must reduce fan motor power by at least 75% during the off cycle. This measure is not applicable if any of the following conditions apply:

- The compressor runs more than 4380 hours annually
- The evaporator fan does not run at full speed all the time
- The evaporator fan motor runs on poly-phase power
- Evaporator does not use off-cycle or time-off defrost.

### DEFINITION OF BASELINE EQUIPMENT

In order for this characterization to apply, the existing condition must be a reach-in or walk-in freezer or cooler with continuously running evaporator fans driven by Electrically Commutated Motors

### DEEMED LIFETIME OF EFFICIENT EQUIPMENT

The expected measure life is assumed to be 13 years.<sup>1393</sup>

### DEEMED MEASURE COST

The measure cost is assumed to be \$69.69 (controller equipment) plus \$92.06 (controller labor) = \$161.75 per motor controlled.<sup>1394</sup>

### LOADSHAPE

Loadshape C46 - Evaporator Fan Control

### COINCIDENCE FACTOR

The measure has deemed kW savings therefore a coincidence factor does not apply.

---

<sup>1393</sup> As recommended in Navigant 'ComEd Effective Useful Life Research Report', May 2018.

<sup>1394</sup> Source: DEER, Work Paper PGE3PREF126 ECM for Walk-In Evaporator with Fan Controller Revision # 2

---



---

**Algorithm**

---

**CALCULATION OF SAVINGS**

Savings are based on a measure created by Energy & Resource Solutions for the California Municipal Utilities Association<sup>1395</sup> and supported by a PGE workpaper. Note that climate differences across all California climate zones result in negligible savings differences, which indicates that the average savings for the California study should apply equally as well to Illinois. Savings found in the aforementioned source are presented in combination with savings from an ECM upgrade, however for the purposes of this measure only those associated with the controller are considered.

**ELECTRIC ENERGY SAVINGS**

$$\Delta kWh = \text{Savings per motor} * \text{motors}$$

Where:

Savings per motor = based on the motor rating of the ECM motor:

Evaporator Fan Motor Rating (of ECM)	Annual kWh Savings/motor
16W	198
1/15 - 1/20HP	293
1/5HP	856
1/3HP	1,419
1/2HP	2,126
3/4HP	3,209

motors = number of fan motors controlled

**SUMMER COINCIDENT PEAK DEMAND SAVINGS**

$$\Delta kW = \text{Peak kW savings per motor (as listed in the table below)} * \text{motors (as defined above)}$$

Evaporator Fan Motor Rating (of ECM)	Peak kW Savings/motor
16W	0.023
1/15 - 1/20HP	0.033
1/5HP	0.098
1/3HP	0.162
1/2HP	0.243
3/4HP	0.366

**FOSSIL FUEL SAVINGS**

N/A

**WATER IMPACT DESCRIPTIONS AND CALCULATION**

N/A

---

<sup>1395</sup> See reference Excel files in TRM Reference Documents folder for derivation of TRM values.

**DEEMED O&M COST ADJUSTMENT CALCULATION**

N/A

**MEASURE CODE: CI-RFG-EVPF-V05-220101**

**REVIEW DEADLINE: 1/1/2025**

## 4.6.7 Strip Curtain for Walk-in Coolers and Freezers

### DESCRIPTION

This commercial measure pertains to the installation of infiltration barriers (strip curtains) on walk-in coolers or freezers. Strip curtains impede heat transfer from adjacent warm and humid spaces into walk-ins when the main door is opened, thereby reducing the cooling load. As a result, compressor run time and energy consumption are reduced. The engineering assumption is that the walk-in door is open for varying durations per day based on facility type, and the strip curtain covers the entire door frame. All algorithms and assumptions are based on prescriptive methodologies detailed by the Regional Technical Forum<sup>1396</sup>, whose source calculations are outlined in ASHRAE's Refrigeration Handbook for calculating refrigeration load from infiltration by air exchange.

This measure was developed to be applicable to the following program types: RF.

If applied to other program types, the measure savings should be verified.

### DEFINITION OF EFFICIENT EQUIPMENT

The efficient equipment is a strip curtain at least 0.06 inches thick added to a walk-in cooler or freezer.<sup>1397</sup> The new strip curtain must cover the entire area of the doorway when the door is opened.

### DEFINITION OF BASELINE EQUIPMENT

The baseline assumption is a walk-in cooler or freezer that previously had either no strip curtain installed or an old, ineffective strip curtain installed.

### DEEMED LIFETIME OF EFFICIENT EQUIPMENT

The expected measure life is assumed to be 4 years.<sup>1398</sup>

### DEEMED MEASURE COST

The incremental capital cost for this measure is \$10.22/sq ft of door opening.<sup>1399</sup>

### LOADSHAPE

Loadshape C22 - Commercial Refrigeration

### COINCIDENCE FACTOR

The summer peak coincidence factor for this measure is 100%.<sup>1400</sup>

---

<sup>1396</sup> Database for UES Measures, Regional Technical Forum, Strip Curtains, version 2.1, September 2019

<sup>1397</sup> Pennsylvania Public Utility Commission Technical Reference Manual, Volume 3: Commercial and Industrial Measures, State of Pennsylvania Act 129 Energy Efficiency and Conservation Program & Act 213 Alternative Energy Portfolio Standards, Revised February 2021 -- Chapter 3.5.8 Strip Curtains for Walk-in Freezers and Coolers.

<sup>1398</sup> DEER 2014 Effective Useful Life.

<sup>1399</sup> The reference for incremental cost is \$10.22 per square foot of door opening (includes material and labor). 2008 Database for Energy-Efficiency Resources (DEER), Version 2008.2.05, "Cost Values and Summary Documentation", California Public Utilities Commission, December 16, 2008.

<sup>1400</sup> The summer coincident peak demand reduction is assumed as the total annual savings divided by the total number of hours per year, effectively assuming the average demand reduction is realized during the peak period. This is a reasonable assumption for refrigeration savings.



**Algorithm**

**CALCULATION OF SAVINGS**

**ELECTRIC ENERGY SAVINGS<sup>1401</sup>**

$$\Delta kWh = \Delta kWh/sq\ ft * A$$

Where:

$\Delta kWh/sq\ ft$  = Average annual kWh savings per square foot of infiltration barrier. Deemed values can be found in the table below

A = Doorway area in square feet.  
 = Actual. If the actual doorway area in square feet is unknown, then use the values found in the table below

Default Energy Savings and Door Area for Strip Curtains<sup>1402</sup>

Type	Pre-Existing Curtains	Energy Savings $\Delta kWh/sq\ ft$	Doorway Area (sqft)
Supermarket - Cooler	Yes	40.9	21
Supermarket - Cooler	No	119.9	
Supermarket - Freezer	Yes	168.5	21
Supermarket - Freezer	No	494.3	
Convenience Store - Cooler	Yes	6.3	21
Convenience Store - Cooler	No	23.6	
Convenience Store - Freezer	Yes	10.0	21
Convenience Store - Freezer	No	33.2	
Restaurant - Cooler	Yes	6.2	21
Restaurant - Cooler	No	22.5	
Restaurant - Freezer	Yes	32.4	21
Restaurant - Freezer	No	114	
Refrigerated Warehouse	Yes	53.4	120
Refrigerated Warehouse	No	153.4	

**SUMMER COINCIDENT PEAK DEMAND SAVINGS**

$$\Delta kW = \Delta kWh / 8766 * CF$$

Where:

<sup>1401</sup> The source algorithm from which the savings per square foot values are determined is based on Tamm’s equation (an application of Bernoulli’s equation) [Kaltverluste durch kuhlraumoffnungen. Tamm W, „Kaltetechnik-Klimatisierung 1966;18;142-144;] and the ASHRAE handbook [American Society of Heating, Refrigeration, and Air-Conditioning Engineers (ASHRAE). 2010. ASHRAE Handbook, Refrigeration: 13.4, 13.6].

<sup>1402</sup> Database for UES Measures, Regional Technical Forum, Strip Curtains, version 2.1, September 2019. Custom edits were made to the workbook in order for savings approach to align with this measure workpaper. The In-Service-Rate (described as the Removal Rate by the RTF workbook) was changed from 25% to 0%. Additionally, a 58% efficacy value was inputted for sites that had existing, but inefficient strip curtains prior to retrofit. This value is sourced from tracer gas measurements on over 100 walk-in refrigeration units during the California Public Utility Commission’s (CPUC) evaluation of the 2006-2008 CA investor owned utility energy efficiency programs. The baseline curtain efficacy rates are taken from short-term monitoring of over 100 walk-in units. “Commercial Facilities Contract Group 2006-2008 Direct Impact Evaluation”, CPUC, February 2010.

8766 = hours per year

CF = Summer Peak Coincidence Factor for the measure  
= 1.0

**FOSSIL FUEL SAVINGS**

N/A

**WATER IMPACT DESCRIPTIONS AND CALCULATION**

N/A

**DEEMED O&M COST ADJUSTMENT CALCULATION**

N/A

**MEASURE CODE: CI-RFG-CRTN-V05-220101**

**REVIEW DEADLINE: 1/1/2027**

## 4.6.8 Refrigeration Economizers

### DESCRIPTION

This measure applies to commercial walk in refrigeration systems and includes two components, outside air economizers and evaporator fan controllers. Economizers save energy by bringing in outside air when weather conditions allow, rather than operating the compressor. Walk-in refrigeration systems evaporator fans run almost all the time; 24 hrs/day, 365 days/yr. This is because they must run constantly to provide cooling when the compressor is running, and to provide air circulation when the compressor is not running. However, evaporator fans are a very inefficient method of providing air circulation. Installing an evaporator fan control system will turn off evaporator fans while the compressor is not running, and instead turn on an energy-efficient 35 watt fan to provide air circulation, resulting in significant energy savings. This measure allows for economizer systems with evaporator fan controls plus a circulation fan and without a circulation fan.

This measure was developed to be applicable to the following program types: RF.

If applied to other program types, the measure savings should be verified. IECC code requires economizers in certain instances and therefore projects relying on code baseline definitions must verify eligibility.

### DEFINITION OF EFFICIENT EQUIPMENT

To qualify for this measure an economizer is installed on a walk in refrigeration system.

### DEFINITION OF BASELINE EQUIPMENT

The baseline condition is a walk-in refrigeration system without an economizer.

### DEEMED LIFETIME OF EFFICIENT EQUIPMENT

The estimated life of this measure is 15 years.<sup>1403</sup>

### DEEMED MEASURE COST

Installation costs can vary considerably depending on system size (larger systems may require multiple economizer units), physical site layouts (locating economizer intakes and ductwork), and controls elected. Therefore, actual site-specific costs should be used.

### LOADSHAPE

Loadshape C22 - Commercial Refrigeration

### COINCIDENCE FACTOR

The summer peak coincidence factor for this measure is assumed to be 0%.<sup>1404</sup>

---



---

### Algorithm

---



---

### CALCULATION OF ENERGY SAVINGS

#### ELECTRIC ENERGY SAVINGS

Electric energy savings is calculated based on whether evaporator fans run all.

#### With Fan Control Installed

---

<sup>1403</sup> Estimated life from DEER Work Paper PGE3PREF126..

<sup>1404</sup> Based on the assumption that humidity levels will most likely be relatively high during the peak period, reducing the likelihood of demand savings.

$$\Delta kWh = [HP * kWhCond] + [(kWEvap * nFans) - kW Circ] * Hours * DCComp * BF - [kWEcon * DCEcon * Hours]$$

Without Fan Control Installed

$$\Delta kWh = [HP * kWhCond] - [kWEcon * DCEcon * Hours]$$

Where:

HP = Horsepower of Compressor  
= actual installed

kWhCond = Condensing unit savings, per hp. (value from savings table)<sup>1405</sup>

	Hermetic / Semi-Hermetic	Scroll	Discus
kWh/HP	1,256	1,108	1,051

Hours = Number of annual hours that economizer operates<sup>1406</sup>

Region (city)	Hours
1 (Rockford)	2,376
2 (Chicago/O’Hare)	1,968
3 (Springfield)	1,728
4 (Bellevue)	1,488
5 (Marion)	1,224

DCComp = Duty cycle of the compressor  
= 50%<sup>1407</sup>

kWEvap = Connected load kW of each evaporator fan  
= If known, actual installed. Otherwise assume 0.126 kW<sup>1408</sup>

kWCirc = Connected load kW of the circulating fan  
= If known, actual installed. Otherwise assume 0.035 kW<sup>1409</sup>

nFans = Number of evaporator fans  
= actual number of evaporator fans

DCEcon = Duty cycle of the economizer fan on days that are cool enough for the economizer to be working

<sup>1405</sup> Savings table uses Economizer Calc.xls. Assume 5HP compressor size used to develop kWh/Hp value. No floating head pressure controls and compressor is located outdoors.

<sup>1406</sup> In the source TRM (VT) this value was 2,996 hrs based on 38° F cooler setpoint, Burlington VT weather data, and 5 degree economizer deadband. The IL numbers were calculated by using weather bin data for each location (number of hours < 38F at each location is the Hours value).

<sup>1407</sup> A 50% duty cycle is assumed based on examination of duty cycle assumptions from refrigeration suppliers (35%-65%), Cooltrol (35%-65%), Natural Cool (70%), Pacific Gas & Electric (58%). Also, manufacturers typically size equipment with a built-in 67% duty factor and contractors typically add another 25% safety factor, which results in a 50% overall duty factor..

<sup>1408</sup> Based on a weighted average of 80% shaded pole motors at 175 watts and 20% PSC motors at 84 watts. Motor wattage and efficiency values referenced from Oak Ridge National Laboratory, “Permanent Magnet Synchronous Motors for Commercial Refrigeration: Final Report”, 2019. Table 1, page xiv; Table 24, page 57.

<sup>1409</sup> Wattage of fan used by Freeaire and Cooltrol. This fan is used to circulate air in the cooler when the evaporator fan is turned off. As such, it is not used when fan control is not present.

- = If known, actual installed. Otherwise assume 63%<sup>1410</sup>
- BF = Bonus factor for reduced cooling load from reduction of waste heat generation as a result of running the evaporator fan less  
= 1.3<sup>1411</sup>
- kWEcon = Connected load kW of the economizer fan  
= If known, actual installed. Otherwise assume 0.227 kW.<sup>1412</sup>

**For example**, adding an outdoor air economizer and fan controls in Rockford to a 5 hp walk in refrigeration unit with 3 evaporator fans would save:

$$\begin{aligned} \Delta kWh &= [\text{hp} * \text{kWhCond}] + [((\text{kWEvap} * \text{nFans}) - \text{kWCirc}) * \text{Hours} * \text{DCComp} * \text{BF}] - [\text{kWEcon} * \text{DCEcon} * \text{Hours}] \\ &= [5 * 1256] + [((0.126 * 3) - 0.035) * 2376 * 0.5 * 1.3] - [0.227 * 0.63 * 2376] \\ &= 6519 \text{ kWh} \end{aligned}$$

**SUMMER COINCIDENT PEAK DEMAND SAVINGS**

$$\Delta kW = \Delta kWh / \text{Hours}$$

**FOSSIL FUEL SAVINGS**

N/A

**WATER IMPACT DESCRIPTIONS AND CALCULATION**

N/A

**DEEMED O&M COST ADJUSTMENT CALCULATION**

N/A

**MEASURE CODE: CI-RFG-ECON-V07-240101**

**REVIEW DEADLINE: 1/1/2028**

<sup>1410</sup> Average of two manufacturer estimates of 50% and 75%.

<sup>1411</sup> Bonus factor (1+ 1/3.5) assumes COP of 3.5, based on the average of standard reciprocating and discus compressor efficiencies with a Saturated Suction Temperature of 20°F and a condensing temperature of 90°F.

<sup>1412</sup> The 227 watts for an economizer is calculated from the average of three manufacturers: Freeaire (186 Watts), Cooltrol (285 Watts), and Natural Cool (218 Watts).

## 4.6.9 Night Covers for Open Refrigerated Display Cases

### DESCRIPTION

This measure is the installation of fitted covers on existing open-type refrigerated and freezer display cases that are deployed during the facility unoccupied hours. Night covers are designed to reduce refrigeration energy consumption by reducing the work done by the compressor. Night covers reduce the heat and moisture entry into the refrigerated space through various heat transfer mechanisms. By fully or partially covering the case opening, night covers reduce the convective heat transfer into the case through reduced air infiltration. Additionally, they provide a measure of insulation, reducing conduction into the case, and also decrease radiation into the case by blocking radiated heat from entering the refrigerated space.

### DEFINITION OF EFFICIENT EQUIPMENT

Curtains or covers on top of open refrigerated or freezer display cases that are applied at least six hours (during off-hours) in a 24-hour period.

### DEFINITION OF BASELINE EQUIPMENT

Refrigerated and freezer, open-type display case in vertical, semi-vertical, and horizontal displays, with no night cover.

### DEEMED LIFETIME OF EFFICIENT EQUIPMENT

The measure life is 5 years, based on DEER 2014.<sup>1413</sup>

### DEEMED MEASURE COST

The incremental capital cost for this measure is \$42 per linear foot of cover installed including material and labor.<sup>1414</sup>

### LOADSHAPE

Loadshape 22: Commercial Refrigeration

### COINCIDENCE FACTOR

N/A – savings occur at night only.

---

### Algorithm

---

### CALCULATION OF ENERGY SAVINGS

#### ELECTRIC ENERGY SAVINGS

$$\Delta\text{kWh} = \text{ES} * \text{L}$$

Where:

ES = the energy savings ( $\Delta\text{kWh}/\text{ft}$ ) found in table below:

---

<sup>1413</sup> 2014 Database for Energy-Efficiency Resources (DEER), Version 2014, “Cost Values and Summary Documentation”, California Public Utilities Commission, January, 2014. Referenced in PG&E workpaper PGECOREF101 Night Covers for Display Cases, July 2014.

<sup>1414</sup> 2014 Database for Energy-Efficiency Resources (DEER), Version 2014, “Cost Values and Summary Documentation”, California Public Utilities Commission, January, 2014. Referenced in PG&E workpaper PGECOREF101 Night Covers for Display Cases, July 2014.

Display Case Description	Case Temperature Range (°F)	Annual Electricity Use kWh/ft <sup>1415</sup>	ES ΔkWh/ft reduction (= 9% reduction of electricity use <sup>1416, 1417, 1418, 1419</sup> )
Vertical Open, Remote Condensing, Medium Temperature	35°F to 55°F	1453	131
Vertical Open, Remote Condensing, Low Temperature	0°F to 30°F	3292	296
Vertical Open, Self-Contained Medium Temperature	35°F to 55°F	2800	252
Horizontal Open, Remote Condensing, Medium Temperature	35°F to 55°F	439	40
Horizontal Open, Remote Condensing, Low Temperature	0°F to 30°F	1007	91
Horizontal Open, Self-Contained, Medium Temperature	35°F to 55°F	1350	121
Horizontal Open, Self-Contained, Low Temperature	0°F to 30°F	2749	247

L = the length of the refrigerated case in linear feet  
 = Actual

**SUMMER COINCIDENT PEAK DEMAND SAVINGS**

Peak savings are null because savings occur at night only.

**FOSSIL FUEL SAVINGS**

N/A

**WATER IMPACT DESCRIPTIONS AND CALCULATION**

N/A

**DEEMED O&M COST ADJUSTMENT CALCULATION**

N/A

<sup>1415</sup> Energy Conservation Standards for Commercial Refrigeration Equipment: Technical Support Document, U.S. Department of Energy, September 2013. The information required to estimate annual energy savings for refrigerated display cases is taken from the 2013-2014 U.S. Department of Energy (DOE) energy conservation standard rulemaking for Commercial Refrigerated Equipment. During the rulemaking process, DOE estimates the energy savings specific to night covers through extensive simulation and energy models that are validated by both manufacturers of night covers and refrigerated cases. The information is also referenced from a study done by Southern California Edison and testing by Technischer Überwachungs-Verein Rheinland, which are used by DOE for the rulemaking process.

<sup>1416</sup> Southern California Edison Refrigeration Technology and Test Center. Effects of the Low Emissivity Shields on Performance and Power Use of a Refrigerated Display Case. 1997. Southern California Edison, Rancho Cucamonga, CA.

<sup>1417</sup> ASHRAE, Effects of Low-E Shields on the Performance and Power Use of a Refrigerated Display Case. 1999

<sup>1418</sup> Connecticut Power & Light, Thermal Night Covers for Refrigerated Supermarket Display Cases. 2014

<sup>1419</sup> Technischer Überwachungs-Verein Rheinland E.V. Laboratory test results for energy savings on refrigerated dairy case, conducted for Econofrost.

**MEASURE CODE: CI-RFG-NCOV-V02-240101**

**REVIEW DEADLINE: 1/1/2029**



## 4.6.10 High Speed Rollup Doors

### DESCRIPTION

This measure entails the installation of High Speed Doors in refrigerated warehouses. High speed doors can save energy by lowering infiltration through a reduction in time that cooled spaces are exposed to ambient outdoor conditions. This in turn can lower the demand on refrigeration systems.

This measure was developed to be applicable to the following program types: RF.

If applied to other program types, the measure savings should be verified.

### DEFINITION OF EFFICIENT EQUIPMENT

To qualify for this measure the installed equipment must be a High Speed Door installed on the loading dock doorway of a refrigerated space. The high speed door is assumed to act as a primary door. It should be noted that for high-traffic applications (about 45 door passages per hour, using the defaults for this measure) a custom analysis is necessary to ensure that high-speed rollup doors will provide savings, because strip curtains may outperform the high speed door, if no other open-door protection device is installed.

### DEFINITION OF BASELINE EQUIPMENT

The baseline equipment is existing strip curtains on doorways to a loading dock. During times of traffic, primary doors are left open, leaving just the strip curtains as open-doorway protection.

### DEEMED LIFETIME OF EFFICIENT EQUIPMENT

The expected measure life is assumed to be 16 years.<sup>1420</sup>

### DEEMED MEASURE COST

The incremental measure cost is \$150/sqft.<sup>1421</sup>

### LOADSHAPE

Loadshape C22 - Commercial Refrigeration

### COINCIDENCE FACTOR

The coincidence factor is assumed to be 1.00.

---

### Algorithm

---

### CALCULATION OF SAVINGS

#### ELECTRIC ENERGY SAVINGS

Electric savings consider the change in loading on the refrigeration system as well as the consumption of the drive on the high speed door. The following algorithms are based heavily on those derived and described in chapter 24 Refrigerated-Facility Loads of the ASHRAE Refrigeration Handbook.

$$\Delta kWh = (0.00008333 * q * D_f * \eta * [D_{tB}(1 - E_B) - D_{tE}(1 - E_E)] - D_{tM}M) * t$$

Where:

0.00008333 = conversion from Btu/h to tons

---

<sup>1420</sup> As recommended in Navigant 'ComEd Effective Useful Life Research Report', May 2018.

<sup>1421</sup> Rite Hite – Industrial High Speed Doors

$q$  = sensible and latent refrigeration load for fully established flow, Btu/h

$$= 3790 * W * H^{1.5} * \left(\frac{Q_s}{A}\right) * \left(\frac{1}{R_s}\right)$$

$W$  = width of doorway, in feet. Custom input.

$H$  = height of doorway, in feet. Custom input.

$\frac{Q_s}{A}$  = Sensible heat load of infiltration air per square foot of door way opening, as read from the following figure and dependent on infiltration air temperature and cooled space temperature. If unknown, infiltration temperature can be assumed to be 50° F,<sup>1422</sup> cooler temperature 35° F, and freezer temperature -10° F,<sup>1423</sup> resulting in values of 0.06 for a cooler and 0.5 for a freezer.

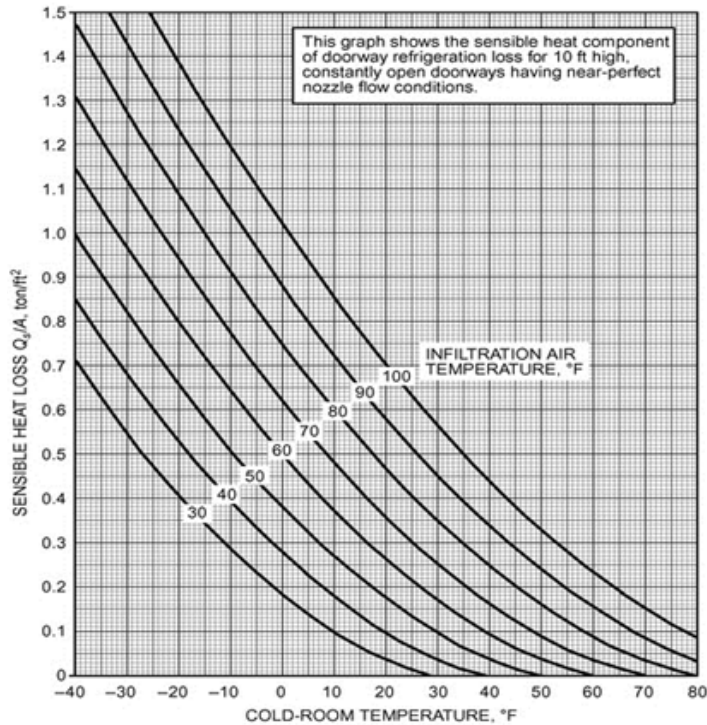

$R_s$  = Sensible heat ratio of the infiltration air heat gain, as read or interpolated from the chart below or from a psychrometric chart, dependent on temperature and relative humidity of infiltration air and cooled space temperature. If unknown, use the same assumptions as previously, with a warm space relative humidity value of 70%,<sup>1424</sup> resulting in values of 0.685 (interpolated) for coolers and 0.73 (interpolated) for freezers.

<sup>1422</sup> Taken to represent the overall annual average temperature in Illinois. TMY3 data for the five weather regions defined by the TRM indicate averages that fall within the range of 47.6 (Rockford) to 55.9 (Marion).

<sup>1423</sup> Refrigerated Warehouse, 2013 California Building Energy Standards, CODES AND STANDARDS ENHANCEMENT INITIATIVE (CASE), March 2011,

<sup>1424</sup> Taken to represent the overall annual average in Illinois. TMY3 data for the five weather regions defined by the TRM indicate averages that fall within the range of 69.1 (Springfield) to 72.1 (Rockford).

Warm Space		Cold Space at 90% rh									
Temp.	rh	Dry-Bulb Temperature, °F									
°F	%	-40	-30	-20	-10	0	10	20	30	40	50
70	100	0.60	0.58	0.56	0.53	0.50	0.47	0.44	0.41	0.37	0.34
	80	0.66	0.64	0.61	0.59	0.56	0.53	0.50	0.48	0.46	0.44
	60	0.72	0.70	0.68	0.66	0.63	0.61	0.59	0.58	0.59	0.64
	40	0.79	0.78	0.76	0.75	0.73	0.72	0.71	0.73	0.80	—
60	100	0.66	0.64	0.62	0.59	0.56	0.52	0.49	0.45	0.41	0.35
	80	0.71	0.69	0.67	0.64	0.62	0.59	0.56	0.53	0.52	0.53
	60	0.77	0.75	0.73	0.71	0.69	0.67	0.65	0.65	0.70	—
	40	0.83	0.82	0.81	0.79	0.78	0.77	0.78	0.83	—	—
50	100	0.72	0.70	0.67	0.64	0.61	0.57	0.53	0.49	0.43	—
	80	0.76	0.74	0.72	0.70	0.67	0.64	0.61	0.59	0.62	—
	60	0.81	0.80	0.78	0.76	0.74	0.72	0.71	0.75	—	—
	40	0.87	0.86	0.84	0.83	0.82	0.82	0.85	—	—	—
40	100	0.77	0.75	0.72	0.69	0.66	0.62	0.57	0.51	—	—
	80	0.81	0.79	0.77	0.74	0.72	0.69	0.66	0.67	—	—
	60	0.85	0.84	0.82	0.80	0.78	0.77	0.79	0.99	—	—
	40	0.90	0.89	0.88	0.87	0.86	0.88	0.97	—	—	—
30	100	0.82	0.80	0.77	0.74	0.70	0.66	0.59	—	—	—
	80	0.85	0.83	0.81	0.79	0.76	0.73	0.73	—	—	—
	60	0.88	0.87	0.86	0.84	0.83	0.83	0.94	—	—	—
	40	0.92	0.91	0.90	0.90	0.91	0.96	—	—	—	—
20	100	0.86	0.84	0.82	0.79	0.75	0.69	—	—	—	—
	80	0.89	0.87	0.85	0.83	0.81	0.80	—	—	—	—
	60	0.91	0.90	0.89	0.88	0.88	0.95	—	—	—	—
	40	0.94	0.94	0.93	0.94	0.97	—	—	—	—	—
10	100	0.90	0.88	0.86	0.83	0.78	—	—	—	—	—
	80	0.92	0.90	0.89	0.87	0.86	—	—	—	—	—
	60	0.94	0.93	0.92	0.92	0.96	—	—	—	—	—
	40	0.96	0.96	0.96	0.98	—	—	—	—	—	—
0	100	0.92	0.91	0.89	0.85	—	—	—	—	—	—
	80	0.94	0.93	0.92	0.91	—	—	—	—	—	—
	60	0.96	0.95	0.95	0.97	—	—	—	—	—	—
	40	0.97	0.97	0.98	—	—	—	—	—	—	—

D<sub>f</sub> = doorway flow factor. Equal to 0.8 for a doorway between a freezer and a dock and 1.1 for a doorway between a cooler and a dock.<sup>1425</sup>

η = Efficiency of refrigeration system (kW/ton). Custom input, if unknown assume 1.6 kW/ton for coolers and 2.4 kW/ton for freezers.<sup>1426</sup>

D<sub>tB</sub> = decimal portion of time doorway is open in the baseline condition. If during facility operating hours, the primary doors are left open, leaving only open-doorway protective devices (e.g., strip curtains) as a barrier, this is considered 1.0. If primary doors are actively operated and do not remain open for the entire time the facility is in operation, refer to the following calculation.

$$D_{tB} = \frac{(P \theta_{pB} + 60 \theta_{oB})}{3600 \theta_d}$$

P = Number of passages through doorway per hour.

θ<sub>pB</sub> = Door open to close time in seconds.

θ<sub>oB</sub> = Time door remains open in minutes.

θ<sub>d</sub> = Period of time considered in hours, 1 hr.

D<sub>tE</sub> = decimal portion of time doorway is open in the efficient condition.

$$D_{tE} = \frac{(P \theta_{pE} + 60 \theta_{oE})}{3600 \theta_d}$$

<sup>1425</sup> ASHRAE, "Refrigerated –Facility Loads", in Refrigeration Handbook 2014: ASHRAE, 2014, 24.7.

<sup>1426</sup> Professional judgement, in alignment with typical freezer and cooler performance found in the Michigan Energy Measures Database (MEMD).

- P = Number of passages through doorway per hour. Custom input; assume 5.9 if unknown.<sup>1427</sup>
- $\Theta_{pE}$  = Door open to close time in seconds. Custom input; assume 7.5 seconds if unknown.<sup>1428</sup>
- $\Theta_{oE}$  = Time door remains open in minutes. Custom input; assume 3 minutes if unknown.<sup>1429</sup>
- $\Theta_d$  = Period of time considered in hours, 1 hr.
- $D_{tM}$  = decimal portion of time high speed door motor is operational.

$$D_{tM} = \frac{P \Theta_{pE}}{3600 \Theta_d}$$

Variables defined above.

- $E_B$  = effectiveness of baseline open-doorway protective device (strip curtains). Equal to 0.85.<sup>1430</sup>
- $E_E$  = effectiveness of efficient open-doorway protective device. Equal to 0, unless an additional protective device exists to limit infiltration during times when the high-speed door is open.
- M = operating input power of the high speed door motor, in kW.  
= Custom input; assume 1.49kW if unknown.<sup>1431</sup>
- t = hours per year when primary doors to the cooled space are open.  
= Custom input; assume 2,959 hrs/yr if unknown.<sup>1432</sup>

#### SUMMER COINCIDENT PEAK DEMAND SAVINGS

$$\Delta kW = (\Delta kWh / t) * CF$$

Where

- CF = Summer peak coincidence factor for this measure  
= 1.0

All other variables as defined above.

#### FOSSIL FUEL SAVINGS

N/A

#### WATER IMPACT DESCRIPTIONS AND CALCULATION

N/A

<sup>1427</sup> ASHRAE, "Refrigerated –Facility Loads", in Refrigeration Handbook 2014: ASHRAE, 2014, 24.11

<sup>1428</sup> ASHRAE, "Refrigerated –Facility Loads", in Refrigeration Handbook 2014: ASHRAE, 2014, 24.6

<sup>1429</sup> Professional judgement.

<sup>1430</sup> ASHRAE, "Refrigerated –Facility Loads", in Refrigeration Handbook 2014: ASHRAE, 2014, 24.7

<sup>1431</sup> Rite Hite – Industrial High Speed Doors, product line commonly uses 2HP drives.

<sup>1432</sup> Based on a ComEd survey that obtained the number of hours per week certain building types operate. Warehouses had an average response of 55.6 and industrials had 58.2. Calculated by taking the simple average of the two and multiplying by 52 weeks/yr.

**DEEMED O&M COST ADJUSTMENT CALCULATION**

Manufacturers suggest annual inspection and maintenance (such as patching tears) of high speed doors. At a minimum, greasing of fittings and oil top-off should be carried out annually. This is estimated at a cost of \$150 per year.<sup>1433</sup>

**MEASURE CODE: CI-RFG-HSRD-V03-220101**

**REVIEW DEADLINE: 1/1/2026**

---

<sup>1433</sup> Assumes approximately 1 hour of maintenance, based on manufacturer product spec sheets.

## 4.6.11 Q-Sync Motors for Walk-in and Reach-in Coolers/Freezers

### DESCRIPTION

This measure is applicable to replacement of an existing, uncontrolled, and continuously operating standard-efficiency shaded-pole, permanent split capacitor (PSC), and electronically commutated (EC) evaporator fan motors in reach-in refrigerated display cases as well as walk-in coolers and freezers.

This measure achieves energy savings by installing a more efficient Q-Sync motor in these scenarios (accompanied with replacement fan assembly as necessary). In addition to motor energy savings, the measure also results in less waste heat for the refrigeration equipment to reject and improves the power factor of the equipment.

This measure is limited to a typical reach-in refrigerated display case with the evaporator fan power of 9-12 Watts and walk-in coolers and freezers with the evaporator fan power of 38-50 Watts. In addition to the motor, replacement of the evaporator fan is necessary to ensure matching airflow is provided (because the fan's speed has been modified). Care must be taken by the installer to ensure airflows remain within the specified range, otherwise fan performance could suffer, causing reliability issues. Q-Sync motors are commonly purchased as a kit, which includes replacement fan blades and shrouds when replacement is necessary.

This measure was developed to be applicable to the following program types: RF, NC.<sup>1434</sup>

If applied to other program types, the measure savings should be verified.

### DEFINITION OF EFFICIENT EQUIPMENT

The replacement unit must be a 9-12 Watt Q-Sync motor with a minimum of 73% motor efficiency or a 38-50 Watt Q-Sync motor with a minimum of 81% motor efficiency (as listed by manufacturer).

### DEFINITION OF BASELINE EQUIPMENT

Depending on existing conditions, one of three baselines is chosen:

Baseline 1: existing shaded-pole motor(s) with no fan control operating 8760 hours continuously in a refrigerated reach-in display case, walk-in cooler, or walk-in freezer.

Baseline 2: EC motor with no fan control operating 8760 hours continuously in a refrigerated reach-in display case.

Baseline 3: existing PSC motor(s) with no fan control operating 8760 hours continuously in a walk-in cooler or freezer.

Baseline 4: blended baseline, consisting of a mix of shaded-pole motors and EC motors that are assumed to be present in retrofit project where accurate counts are unknown or difficult to determine. It is assumed that existing motors have no fan control and operate 8760 hours continuously in refrigerated reach-in display cases.

### DEEMED LIFETIME OF EFFICIENT EQUIPMENT

The deemed measure life is ten years.<sup>1435</sup>

### DEEMED MEASURE COST

Actual measure costs should be used if available. If costs are not available, the following deemed measure cost can be used.<sup>1436</sup>

---

<sup>1434</sup> Customers should be encouraged to check with the manufacturer to determine any impact on warranty of new equipment due to installing Q-sync fan/motor assemblies.

<sup>1435</sup> Based on communication with QM Power representative, April 16, 2018. See reference document "4.16.2018 Email.msg".

<sup>1436</sup> Based on communication with QM Power representative, April 24, 2018. See reference document "4.24.2018 Email.msg".

Measure	Material Unit (Each)	Material Cost / Unit	Labor Unit (Hours)	Labor Rate / Unit	Total Cost / Unit
9-12-watt Q-Sync motor (including replacement fan kit)	1	\$52	0.25	\$120	\$82
38-50-watt Q-Sync motor (including replacement fan kit)	1	\$50	0.50	\$120	\$110

Note: the material unit cost is based on a large-scale retrofit project.

**LOADSHAPE**

Loadshape C53 - Flat

**COINCIDENCE FACTOR**

The peak kW coincidence factor is 100%

---

**Algorithm**

---

**CALCULATION OF ENERGY SAVINGS**

To determine the savings associated with the Q-Sync motor measure we utilized the field study results provided by Oak Ridge National Laboratory (ORNL)<sup>1437</sup> and Alternative Energy Systems Consulting (AESC)<sup>1438</sup> for refrigerated display cases, and the field study results provided by Slipstream<sup>1439</sup> and ORNL<sup>1440</sup> for walk-in coolers and freezers.

For refrigerated display cases, in 2015, ORNL conducted a side-by-side comparison of Q-Sync motors with EC motors in a 16 ft medium-temperature vertical multi-deck refrigerated display case at an Hy-Vee Supermarket in the Kansas City metropolitan area. A retrofit was done on the display case that contained four 12 W EC evaporator fan motors, two in each 8 ft section. Two existing EC motors in one of the 8 ft sections were replaced with two 12 W Q-Sync motors. The initial results show that Q-Sync motors consumed approximately 16.4 watts per motor, and EC motors consumed approximately 22.6 watts per motor.<sup>1441</sup>

---

<sup>1437</sup> Brian A. Fricke and Bryan R. Becker, “Q-Sync Motors in Commercial Refrigeration: Preliminary Test Results and Projected Benefits,” Oak Ridge National Laboratory, September 2015.

<sup>1438</sup> M. Valmiki and Antonio Corradini, “Energy Savings of Permanent Magnet Synchronous Fan Motor Assembly Refrigerated Case Evaporators,” Alternative Energy Systems Consulting, August 2016.

<sup>1439</sup> Xiaohui Zhou, et al, “Q-Sync Motor Performance in Walk-in Coolers and Freezers: Field Test for ComEd Emerging Technologies,” Slipstream, March 2019.

<sup>1440</sup> Brian A. Fricke and Bryan R. Becker, “Permanent Magnet Synchronous Motors for Commercial Refrigeration: Final Report,” Oak Ridge National Laboratory, July 2018.

<sup>1441</sup> Brian A. Fricke and Bryan R. Becker, “Q-Sync Motors in Commercial Refrigeration: Preliminary Test Results and Projected Benefits,” Oak Ridge National Laboratory, September 2015.

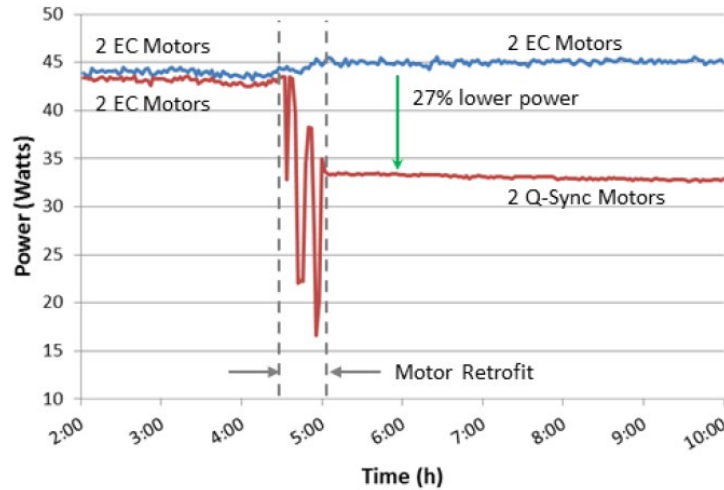

In comparison, the 2011 study by Navigant and PNNL determined that a 12 w shade-pole motor ‘s actual power is 60.0 watts for use in commercial refrigeration equipment at design condition,<sup>1442</sup> even though some manufacturers also pointed out that “there could be significant variations in efficiency between motors of the same type but different models.” In the AESC study, the field test showed that the average input power for each of the 13 shaded pole motors retrofitted is 41.6 watts. As a compromise between the two studies, we use 50.0 watts as a representative number for shaded pole motors in our calculation. The average evaporator fan motor powers in refrigerated cases are summarized in the following table.

	Shaded-pole motor	PSC motor	Q-Sync motor
Average evaporator fan motor power in refrigerated display cases (watt)	50.0	22.6	16.4

For walk-in coolers and freezers, in 2019, Slipstream conducted a field study in three small businesses in Illinois retrofitting a total of 18 evaporator fan motors in 7 walk-in coolers or freezers. The average input power for each of the existing 16 shaded-pole motors was 131.6 watts, and 58.4 watts for each of the existing two PSC motors. The average input power for each of the 18 Q-Sync motors post-retrofit was 40.1 watts. In the ORNL 2018 field study on walk-in cooler/freezers in two supermarkets, the average input power for each of the existing 20 shaded-pole fan motors was 111.5 watts, and 61.4 watts for each of the existing 73 PSC motors. The average input power for each of the 93 Q-Sync motors post-retrofit was 36.6 watts. Combining both studies’ results, the average powers for evaporator fan motors pre- and post-retrofit are listed in the following table:

	Shaded-pole motor	PSC motor	Q-Sync motor
Average evaporator fan motor power in walk-in coolers/freezers (watt)	120.4	61.3	37.2

**For refrigerated display cases:**

The electrical energy savings for replacing a shaded-pole motor with a Q-Sync motor in a retrofit project is calculated by the difference of the two motors demonstrated power draw multiplied by the annual operating hours. For med-

<sup>1442</sup> NCI (Navigant Consulting Inc.) and PNNL (Pacific Northwest National Laboratory), “Preliminary Technical Support Document (TSD): Energy Conservation Program for Certain Commercial and Industrial Equipment: Commercial Refrigeration Equipment,” Appliances and Commercial Equipment Standards, Building Technologies Program, Office of Energy Efficiency and Renewable Energy, US Department of Energy, Washington, D.C., 2011.



temperature cases, T is 8,760 hours. For low-temp freezer cases, T is 8,578 hours considering daily 30-minute defrost cycles during which fans are not powered.<sup>1443</sup>

$$\begin{aligned} &\text{Motor energy savings (Baseline 1, med-temp, per motor)} \\ &= (50 \text{ W} - 16.4 \text{ W}) \times 8760 \text{ hours} / 1000 = 294.336 \text{ kWh} \end{aligned}$$

$$\begin{aligned} &\text{Motor energy savings (Baseline 1, low-temp, per motor)} \\ &= (50 \text{ W} - 16.4 \text{ W}) \times 8578 \text{ hours} / 1000 = 288.221 \text{ kWh} \end{aligned}$$

The electrical energy savings for replacing an EC motor with a Q-Sync motor in a retrofit project is calculated by the difference of the two motors demonstrated power draw multiplied by the annual operating hours (8760 hours):

$$\begin{aligned} &\text{Motor energy savings (Baseline 2, med-temp, per motor)} \\ &= (22.6 \text{ W} - 16.4 \text{ W}) \times 8760 \text{ hours} / 1000 = 54.312 \text{ kWh} \end{aligned}$$

$$\begin{aligned} &\text{Motor energy savings (Baseline 2, low-temp, per motor)} \\ &= (22.6 \text{ W} - 16.4 \text{ W}) \times 8578 \text{ hours} / 1000 = 53.184 \text{ kWh} \end{aligned}$$

The reduced motor power will also reduce refrigeration load. Assuming the power to drive the evaporator fan is converted to heat inside the display cases at 100% rate, the reduction in refrigeration system compressor power can be calculated using the following equation:

$$\Delta kWh_{refrigeration} = \frac{\Delta kWh_{motor}}{COP},$$

where COP is the Coefficient of Performance of refrigeration systems in the supermarket display cases. For med-temperature cases, the average COP is 2.5<sup>1444</sup>. For low-temp freezer cases, the average COP is 1.3.<sup>1445</sup>

The refrigeration energy savings can be calculated based on above numbers:

$$\text{Refrigeration energy savings (Baseline 1, med-temp, per motor)} = 117.734 \text{ kWh}$$

$$\text{Refrigeration energy savings (Baseline 1, low-temp, per motor)} = 221.708 \text{ kWh}$$

$$\text{Refrigeration energy savings (Baseline 2, med-temp, per motor)} = 21.724 \text{ kWh}$$

$$\text{Refrigeration energy savings (Baseline 2, low-temp, per motor)} = 40.910 \text{ kWh}$$

The overall energy savings are the sums of the motor energy savings and the refrigeration energy savings:

$$\text{Overall energy savings (Baseline 1, med-temp, per motor)} = 412.070 \text{ kWh}$$

$$\text{Overall energy savings (Baseline 1, low-temp, per motor)} = 509.929 \text{ kWh}$$

$$\text{Overall energy savings (Baseline 2, med-temp, per motor)} = 76.036 \text{ kWh}$$

$$\text{Overall energy savings (Baseline 2, low-temp, per motor)} = 94.094 \text{ kWh}$$

**For walk-in coolers and freezers:**

The electrical energy savings for replacing a shaded-pole motor with a Q-Sync motor in a retrofit project is calculated by the difference of the two motors demonstrated power draw multiplied by the annual operating hours. For coolers, T is 8,760 hours. For freezers, T is 8,578 hours considering daily 30-minute defrost cycles during which fans are not powered.

<sup>1443</sup> M M. Valmiki and Antonio Corradini, "Energy Savings of Permanent Magnet Synchronous Fan Motor Assembly Refrigerated Case Evaporators," Alternative Energy Systems Consulting, August 2016.

<sup>1444</sup> Michael Deru, et al, "U.S. Department of Energy Commercial Reference Building Models of National Building Stock," NREL Report TP-5500-46861, February 2011.

<sup>1445</sup> Michael Deru, et al, "U.S. Department of Energy Commercial Reference Building Models of National Building Stock," NREL Report TP-5500-46861, February 2011.

Motor energy savings (Baseline 1, med-temp, per motor)

$$= (120.4 \text{ W} - 37.2 \text{ W}) \times 8760 \text{ hours} / 1000 = 728.832 \text{ kWh}$$

Motor energy savings (Baseline 1, low-temp, per motor)

$$= (120.4 \text{ W} - 37.2 \text{ W}) \times 8578 \text{ hours} / 1000 = 713.690 \text{ kWh}$$

The electrical energy savings for replacing a PSC motor with a Q-Sync motor in a retrofit project is calculated by the difference of the two motors demonstrated power draw multiplied by the annual operating hours (8760 hours):

Motor energy savings (Baseline 3, med-temp, per motor)

$$= (61.3 \text{ W} - 37.2 \text{ W}) \times 8760 \text{ hours} / 1000 = 211.116 \text{ kWh}$$

Motor energy savings (Baseline 3, low-temp, per motor)

$$= (61.3 \text{ W} - 37.2 \text{ W}) \times 8578 \text{ hours} / 1000 = 206.730 \text{ kWh}$$

The reduced motor power will also reduce refrigeration load. Assuming the power to drive the evaporator fan is converted to heat inside the display cases at 100% rate, the reduction in refrigeration system compressor power can be calculated using the following equation:

$$\Delta kWh_{refrigeration} = \frac{\Delta kWh_{motor}}{COP},$$

where COP is the Coefficient of Performance of refrigeration systems in the supermarket display cases. For med-temperature cases, the average COP is 2.5. For low-temp freezer cases, the average COP is 1.3.

The refrigeration energy savings can be calculated based on above numbers:

Refrigeration energy savings (Baseline 1, med-temp, per motor) = 291.532 kWh

Refrigeration energy savings (Baseline 1, low-temp, per motor) = 548.992 kWh

Refrigeration energy savings (Baseline 3, med-temp, per motor) = 84.446 kWh

Refrigeration energy savings (Baseline 3, low-temp, per motor) = 159.023 kWh

The overall energy savings are the sums of the motor energy savings and the refrigeration energy savings:

Overall energy savings (Baseline 1, med-temp, per motor) = 1020.364 kWh

Overall energy savings (Baseline 1, low-temp, per motor) = 1262.682 kWh

Overall energy savings (Baseline 3, med-temp, per motor) = 295.562 kWh

Overall energy savings (Baseline 3, low-temp, per motor) = 365.753 kWh

### **ELECTRIC ENERGY SAVINGS**

If the numbers of existing shaded-pole motors, EC motors to be retrofitted are known (Baseline 1,2, & 3):

$$\Delta kWh = \text{Overall annual savings per motor} * \text{Motors}$$

Where overall energy savings per motor can be as specified in the following table:

Evaporator Fan Motor Rating (of Q-Sync motor)	Baseline	Annual kWh Savings/motor
9-12W	shaded-pole motor, med-temp	412.070
9-12W	shaded-pole motor, low-temp	509.929
9-12W	EC motor, med-temp	76.036
9-12W	EC motor, low-temp	94.094
38-50W	shaded-pole motor, med-temp	1,020.364
38-50W	shaded-pole motor, low-temp	1,262.682
38-50W	PSC motor, med-temp	295.562
38-50W	PSC motor, low-temp	365.753

Motors = number of fan motors replaced

For refrigerated display cases, if the numbers of existing shaded-pole motors and EC motors are unknown in a retrofit project (Baseline 3):

$$\Delta kWh = [W_{med-temp} (W_{SPM} \times S_{SPM-med} + W_{ECM} \times S_{ECM-med}) + W_{low-temp} (W_{SPM} \times S_{SPM-low} + W_{ECM} \times S_{ECM-low})] * Motors$$

Motors = number of fan motors replaced

S = annual energy savings per motor, by type. Savings for each different type ( $S_{SPM-med}$ ,  $S_{SPM-low}$ ,  $S_{ECM-med}$ ,  $S_{ECM-low}$ ) can be looked up from the table above.

W = weighting factors. The weights for the medium-temperature and low-temperature applications ( $W_{med-temp}$  and  $W_{low-temp}$ ) should be calculated based on the actual numbers of motors in a retrofit project, and the sum of the two weights should equal to 1. If these weights cannot be accurately obtained, the estimated weights ( $W_{med-temp}^*$  and  $W_{low-temp}^*$ )<sup>1446</sup> from the table below can be used (the  $W_{SPM}$  and  $W_{ECM}$  numbers are slightly adjusted by +/-5% based on national averages in the 2015 ORNL study, reflecting some shaded pole motors may have been replaced with EC motors in the past few years).<sup>1447</sup>

Application	WSPM	WECM	Wmed-temp*	Wlow-temp*
Supermarkets	0.6	0.4	0.68	0.32
Other Food Retail Formats	0.8	0.2	0.68	0.32
Other Retail Categories	0.7	0.3	0.68	0.32
Restaurants and Bars	0.85	0.15	0.68	0.32
Beverage Vending Machines	0.85	0.15	0.68	0.32

For walk-in coolers and freezers, if the existing motor types are unknown in a retrofit project, it can be assumed they are PSC motors, as from industry survey in the 2018 ORNL study,<sup>1448</sup> 95% of the 38-50 watt evaporator fan motors are PSC motors.

### SUMMER COINCIDENT PEAK DEMAND SAVINGS

$$\Delta kW = \Delta kWh / \text{Hours} * CF$$

Where:

<sup>1446</sup> ASHRAE, "ASHRAE Handbook – Refrigeration," ASHRAE, 2018.

<sup>1447</sup> NCI (Navigant Consulting Inc.) and PNNL (Pacific Northwest National Laboratory), "Preliminary Technical Support Document (TSD): Energy Conservation Program for Certain Commercial and Industrial Equipment: Commercial Refrigeration Equipment," Appliances and Commercial Equipment Standards, Building Technologies Program, Office of Energy Efficiency and Renewable Energy, US Department of Energy, Washington, D.C., 2011.

<sup>1448</sup> Brian A. Fricke and Bryan R. Becker, "Permanent Magnet Synchronous Motors for Commercial Refrigeration: Final Report," Oak Ridge National Laboratory, July 2018.

$\Delta$ kWh = Gross customer annual kWh savings for the measure, as listed above

Hours = Full Load hours per year  
 = 8,766 (med-temp); 8,578 (low-temp)

CF = Summer Peak Coincident Factor  
 = 1.0

Other variables as defined above.

The following table provides the resulting kW savings (per motor):

Evaporator Fan Motor Rating (of Q-Sync motor)	Baseline	kW Savings/motor
9-12W	shaded-pole motor, med-temp	0.047
9-12W	shaded-pole motor, low-temp	0.059
9-12W	EC motor, med-temp	0.009
9-12W	EC motor, low-temp	0.011
38-50W	shaded-pole motor, med-temp	0.116
38-50W	shaded-pole motor, low-temp	0.147
38-50W	PSC motor, med-temp	0.034
38-50W	PSC motor, low-temp	0.043

**FOSSIL FUEL SAVINGS**

N/A

**WATER AND OTHER NON-ENERGY IMPACT DESCRIPTIONS AND CALCULATION**

N/A

**DEEMED O&M COST ADJUSTMENT CALCULATION**

There is no O&M cost adjustment for replacing shaded pole or EC motors with Q-Sync motors in reach-in refrigerated display case applications. From the 2015 ORNL study,<sup>1449</sup> the 2016 AESC study,<sup>1450</sup> and the manufacturer,<sup>1451</sup> there is no expected degradation in equipment performance after the retrofits, and therefore no O&M cost differences are expected between baseline and efficient measures.

**MEASURE CODE: CI-RFG-QMF-V03-220101**

**REVIEW DEADLINE: 1/1/2026**

<sup>1449</sup> Brian A. Fricke and Bryan R. Becker, “Q-Sync Motors in Commercial Refrigeration: Preliminary Test Results and Projected Benefits,” Oak Ridge National Laboratory, September 2015.

<sup>1450</sup> M M. Valmiki and Antonio Corradini, “Energy Savings of Permanent Magnet Synchronous Fan Motor Assembly Refrigerated Case Evaporators,” Alternative Energy Systems Consulting, August 2016.

<sup>1451</sup> Based on communication with QM Power representative, August 22, 2018. See reference document “8.22.2018 Email.msg”.

## 4.6.12 Variable Speed Drive for Condenser Fans

### DESCRIPTION

This measure is applicable to VFDs installed on condenser fan motors operating in supermarket refrigeration systems.

Where a baseline condenser motor load operates at a fixed-speed, VFDs generate energy and cost savings by modulating frequency and voltage to match the load on the condensers.<sup>1452</sup> Savings result from the resulting fan speed variation.

This measure is applicable to motors between 0.5 horsepower and 1.5 horsepower.

This measure was developed to be applicable to the following program types: RF, TOS.

If applied to other program types, the measure savings should be verified.

### DEFINITION OF EFFICIENT EQUIPMENT

This measure applies to retrofitted installation of condenser fan motors in supermarkets where no ability to modulate frequency and voltage for fan-speed variation exists. Savings are based on the application of VFDs to baseline load conditions defined as pre-installation load compared to post-installation load.

### DEFINITION OF BASELINE EQUIPMENT

The time-of-sale baseline is a new motor installed without a VFD or other methods of control. Retrofit baseline is an existing motor operating as is.

### DEEMED LIFETIME OF EFFICIENT EQUIPMENT

The expected measure life for VFD condenser fan applications is 15 years.<sup>1453</sup>

### DEEMED MEASURE COST

Customer costs will be used when available. For motor sizes 0.5 to 1.5 HP the default measure cost is \$1,170/HP. Custom costs must be gathered for other motor sizes.

### LOADSHAPE

C22-commercial refrigeration.

### COINCIDENCE FACTOR

The demand savings factor (DSF) is already based upon coincident savings, and thus there is no additional coincidence factor for this characterization.

---

### Algorithm

---

### CALCULATION OF ENERGY SAVINGS

Energy savings is based on a pre- and post-treatment test. The pre-treatment period being nearly three months in duration with post-treatment of a similar period. Both periods include significant average outdoor temperature (OAT) changes. Measurement of energy savings relies on regression of condenser fan energy use against ambient temperature. These estimates were made on each condenser using both pre- and post-VFD installation; comparison

---

<sup>1452</sup> Romberger, Jeff. Wed. "Chapter 18: Variable Frequency Drive Evaluation Protocol. The Uniform Methods Project: Methods for Determining Energy Efficiency Savings for Specific Measures". United States. doi:10.2172/1365710.

<sup>1453</sup> Efficiency Vermont TRM 3/16/2015 pp 19 for motor end use-variable frequency drives.

of the two yields savings.<sup>1454</sup>

**ELECTRIC ENERGY SAVINGS**

$$\text{Annual } \Delta\text{kWh}_{\text{condenser}} = \text{No. fans} * \text{HP/fan} * \text{kWh savings/HP/Zone}$$

Zone	kWh savings/HP
1 (Rockford)	1,480
2 (Chicago)	1,500
3 (Springfield)	1,430
4 (Belleville)	1,430
5 (Marion)	1,480

**For example**, for a condenser with 5 fans, each rated at 1.5 HP in Chicago (Zone 2):

$$\begin{aligned} \text{Annual } \Delta\text{kWh}_{\text{condenser}} &= 5 * 1.5 * 1,500 \\ &= 11,250 \text{ kWh} \end{aligned}$$

**SUMMER COINCIDENT PEAK DEMAND SAVINGS**

N/A

**FOSSIL FUEL SAVINGS**

N/A

**WATER AND OTHER NON-ENERGY IMPACT DESCRIPTIONS AND CALCULATION**

N/A

**DEEMED O&M COST ADJUSTMENT CALCULATION**

Variable frequency drives, anecdotally, increase motor life because they allow for soft-start and soft shutdown. This would lead to O&M savings from replacing motors. Unfortunately, there is currently insufficient evidence to quantify this savings, so no deemed O&M savings can be claimed at this time.

**MEASURE CODE: CI-RFG-VSC-V02-200101**

**REVIEW DEADLINE: 1/1/2025**

<sup>1454</sup> Pre- and post-VFD retrofit kWh consumption were derived from measurement of 14 condensers at 4 supermarkets in Rockford, IL. Annual savings in each Zone is the product of the number of hours in each 5-degree F Typical Meteorological Year temperature bin multiplied by the mean savings across the 14 condensers measured in the study. These estimates represent means from 10,000 simulations that include confidence intervals at the 90 percent level of +/-330, +/-330, +/-300, +/-320, and +/-310 for zones 1, 2, 3, 4, and 5, respectively. Detailed methods, assumptions, and calculations are found in “Variable Frequency Drive Energy Savings in Supermarkets Report. Slipstream, September, 30 2018” [pending report publication by ComEd.] Once published, the report will be made available to Illinois TRM Stakeholders for reference.

### 4.6.13 Add Doors to Open Refrigerated Display Cases

#### DESCRIPTION

Open display cases are typically found in grocery and convenience stores and have been a preference of store owners because they allow customers a clear view and easy access to refrigerated products. This measure is retrofitting existing, open, refrigerated display cases by adding and installing doors. The baseline equipment is an open vertical or horizontal display case with no doors or covering. The efficient equipment is the installation of solid doors on the existing display case. Replacement of open display cases with new display cases with doors is not covered under this measure characterization.

Energy savings are based on air infiltration reduction from the addition of doors to the open display cases. The air infiltration reductions assume a reduced heat gain and subsequent reduced load on the refrigeration compressors. Both radiant and conduction heat losses were factored into the analysis as well. Energy savings are based on a per linear foot of display case.

Interactive HVAC energy savings were also included in the measure savings analysis. The HVAC interactive effects calculation assesses the measure's impact on the heating and cooling equipment. With adding a door to an open refrigerated display case, excess cold air leaking into the conditioned space no longer has to be treated by the heating system, resulting in additive savings. Similarly, the reduction in cold air from the open refrigerated display case no longer supplements the efforts of the space cooling equipment, which results in an overall increase in its consumption.

High, medium, and low temperature cases are eligible for this measure; however, the measure assumptions detailed in this characterization are based on medium temperature display cases, with the installation of zero energy doors, as it was deemed the most likely candidate for participation in this measure. Open low temperature or freezer display cases are not common. If the retrofitted door has LED fixtures, it is recommended to leverage '4.5.4 LED Bulbs and Fixtures' for quantifying savings and measure benefits.

This measure was developed to be applicable to the following program types: RF.

If applied to other program types, the measure savings should be verified.

#### DEFINITION OF EFFICIENT EQUIPMENT

The efficient condition is retrofitting an existing open, refrigerated, display case by adding doors.

#### DEFINITION OF BASELINE EQUIPMENT

The baseline condition is an open, refrigerated, display case without any covering.

#### DEEMED LIFETIME OF EFFICIENT EQUIPMENT

The expected measure life is 15 years.<sup>1455</sup>

#### DEEMED MEASURE COST

The incremental cost, which includes both material and labor, differs depending on whether or not the installed door is equipped with LED lighting. The estimated incremental cost for doors without LED lighting is \$390 per linear foot. The incremental cost for doors with LED lighting is \$419 per linear foot.<sup>1456</sup>

---

<sup>1455</sup> The measure life is sourced from the PG&E Workpaper, "Add Doors to Open Medium Temperature Cases – PGE3PREF116 R3", June 2019.

<sup>1456</sup> The incremental cost is sourced from the PG&E Workpaper, "Add Doors to Open Medium Temperature Cases – PGE3PREF116 R3", June 2019. The incremental cost for retrofitting new doors on existing refrigerated display cases is the

**LOADSHAPE**

Loadshape C03 - Commercial Cooling

Loadshape 22: Commercial Refrigeration

**COINCIDENCE FACTOR**

There are two components to the demand savings of this measure, one that impacts the refrigeration equipment itself, and another that has an interactive impact on the space cooling equipment. As a result, the measure details two summer coincidence peak demand factors.

---

**Algorithm**

---

**CALCULATION OF SAVINGS**

**ELECTRIC ENERGY SAVINGS**

$$\Delta kWh = ((\Delta HG * CL) / (EER * 1000) * 8760) + (MMBtu_{HVAC\ Cool} * CL * (1 / SEER) * 1000) - kWh_{Night\ Covers} - kWh_{Added\ Lights}$$

Where:

- $\Delta kWh$  = gross customer annual kWh savings
- $\Delta HG$  = Heat Gain, the decreased load or the reduced heat gain on the open refrigerated display case with the installation of a door (Btu/hr-linear foot)  
= 1,172 Btu/h-ft<sup>1457</sup> for vertical cases or 202.3 Btu/h-ft for horizontal cases<sup>1458</sup>.
- CL = Case Length, refrigerated case length in feet  
= Actual
- EER = Energy Efficiency Ratio; display case compressor efficiency (Btu/hr-watt)  
= 11.36<sup>1459</sup>
- 1000 = Conversion from watts to kilowatts (W / kW)
- 8760 = Annual operating hours of the refrigerated display case<sup>1460</sup>

---

material cost of the door and the labor cost required for installation. The material cost of the doors is \$331 per linear foot with LED lighting and \$301 per linear foot without LED lighting. And the installation cost is \$88 per linear foot.

<sup>1457</sup> The change in heat gain is sourced as the typical value for a medium temperature vertical display case adding doors from the PG&E Workpaper, "Add Doors to Open Medium Temperature Cases - PGE3PREF116 R3", June 2019. The workpaper assumes a net reduction in heat gain with the installation of doors on open refrigerated display cases. The primary benefits account for the decrease in excess heat entering the display case from air infiltration. Radiation and conduction heat gains were also included in the derivation of this value. Additionally, the net heat gain has built in assumptions on how often the refrigerated case doors will be used and the display case accessed by customers and site associates, reducing some of the air infiltration benefits of the new door.

<sup>1458</sup> Average load difference between Hussmann open horizontal cases and lid horizontal cases across various configurations.

<sup>1459</sup> Average EER values were calculated as the average of standard reciprocating and disc compressor efficiencies, using a typical condensing temperature of 90°F and saturated suction temperatures (SST) of 20°F for medium temperature applications. The efficiency analysis and product review is sourced from the Efficiency Vermont TRM, which utilizes data from Emerson Climate Technology software. Medium temperature cases have an EER value of 11.36.

<sup>1460</sup> The measure assumes the baseline equipment is not employing night covers or any other covering but is in fact left open for the duration of its operation.



$MMBtu_{HVAC\ Cool}$  = Total cooling load increase on the HVAC equipment per linear foot of display case. Varies by location:<sup>1461</sup>

Zone	$MMBtu_{HVAC\ Cool\ Vertical}$	$MMBtu_{HVAC\ Cool\ Horizontal}$
1 (Rockford)	-2.632	-0.454
2 (Chicago)	-2.763	-0.477
3 (Springfield)	-3.284	-0.567
4 (Belleville)	-3.254	-0.562
5 (Marion)	-3.335	-0.576

SEER = Seasonal Energy Efficiency Ratio; HVAC equipment operating efficiency (Btu/hr-watt)  
= 13.00<sup>1462</sup>

$kWh_{Night\ Covers}$  = Reduction in energy savings if existing display case utilizes night covers (kWh/linear-ft)  
= 0 if no night covers are deployed. See table below if display case uses night covers.

Display Case Description	Case Temperature Range (°F)	$\Delta kWh/ft$ reduction (= 9% reduction of electricity use <sup>1463,1464</sup> )
Vertical Open, Remote Condensing, Medium Temperature	35°F to 55°F	131
Vertical Open, Remote Condensing, Low Temperature	0°F to 30°F	296
Vertical Open, Self-Contained Medium Temperature	35°F to 55°F	252

$kWh_{Added\ Lights}$  = Reduction in energy savings if new lighting is added to the case (kWh/linear-ft)  
= 0 if no lighting is added, or if lighting is added but existing lighting is removed. If lighting is retrofit, determine case lighting savings using '4.5.4 LED Bulbs and Fixtures'.  
= Actual installed equipment specifications or use case lighting values from '4.5.4 LED Bulbs and Fixtures'.

<sup>1461</sup> The  $MMBtu$  increase on the HVAC cooling equipment is based on an outdoor air temperature bin analysis, the total hours of operation of the cooling system, and the building's overall loss of additional cooling as a result of the installation of the doors on the open refrigerated display case. The analysis assumes a certain amount of conditioned air has to be treated to replace the air previously cooled by the display case. Furthermore, the analysis assumes an increased load on the cooling system, at outdoor temperatures above 60°F. A 25% disabling factor was also applied to account for some of the cold air pouring out of the display case and subcooling the site's conditioned space, which will not trigger a thermostatic response from the HVAC equipment. For more information on the analysis used to derive the load increase on the HVAC cooling equipment per linear foot of display case, please see the 'HVAC IE' tab in the "IL TRM\_Add Doors\_Analysis\_Mar 2021.xlsx".

<sup>1462</sup> In light of limited existing market data for the efficiency of commercial air condition equipment in Iowa grocery and convenience stores, SEER assumptions are conservatively sourced from IECC 2012.

<sup>1463</sup> Southern California Edison Refrigeration Technology and Test Center. Effects of the Low Emissivity Shields on Performance and Power Use of a Refrigerated Display Case. 1997. Southern California Edison, Rancho Cucamonga, CA. See '4.6.9 Night Covers' for more detail.

<sup>1464</sup> Technischer Überwachungs-Verein Rheinland E.V. Laboratory test results for energy savings on refrigerated dairy case, conducted for Econofrost. See '4.6.9 Night Covers' for more detail.

**For example**, a grocery store in Chicago installed zero energy doors on four open refrigerated cases that do not use night covers, which amounted to 12 linear feet of retrofitted display cases, savings the site:

$$\begin{aligned} \Delta kWh &= ((1172 * 12) / (11.36 * 1000) * 8760) + (-2.763 * 12 * (1 / 13) * 1000) \\ &= 8,295 kWh \end{aligned}$$

**SUMMER COINCIDENT PEAK DEMAND SAVINGS**

$$\begin{aligned} \Delta kW &= (((\Delta HG * CL) / (EER * 1000)) - kW_{Added\ Lights}) * CF_{Refrigeration} \\ &+ ((MMBtu_{HVAC\ Cool} / HourS_{Cool} * CL * (1 / SEER) * 1000) * CF_{Cool}) \end{aligned}$$

Where:

HourS<sub>Cool</sub> = Total combined hours the site is providing cooling. Varies by location:<sup>1465</sup>

Zone	Hours <sub>Cool</sub>
1 (Rockford)	2,994
2 (Chicago)	3,143
3 (Springfield)	3,736
4 (Belleville)	3,702
5 (Marion)	3,794

kW<sub>Added Lights</sub> = Reduction in demand savings if new lighting is added to the case (kW/linear-ft)  
 = 0 if no lighting is added, or if lighting is added but existing lighting is removed. If lighting is retrofit, determine case lighting savings using '4.5.4 LED Bulbs and Fixtures'.  
 = Actual installed equipment specifications or use case lighting values from '4.5.4 LED Bulbs and Fixtures'.

CF<sub>Refrigeration</sub> = Summer peak coincidence factor for the refrigerated display case  
 = 0.964

CF<sub>Cool</sub> = Summer peak coincidence factor for the HVAC cooling system. This is the summer system peak coincidence factor for commercial dooling (during system peak hours)  
 = 0.913<sup>1466</sup>

**FOSSIL FUEL SAVINGS**

$$\Delta Therms = (MMBtu_{HVAC\ Heat} * CL * (1 / AFUE) * 10$$

Where:

ΔTherms = gross customer annual therms savings

<sup>1465</sup> The total combined hours in which the site is providing cooling is based on an outdoor air temperature bin analysis, where the site is conditioning cold air at outdoor temperatures of 60°F and above. Weather data was sourced from TMY3 data for the specific locations. For more information on the derivation of these hours, please see 'HVAC IE' tab in the "IL TRM\_Add Doors\_Analysis\_Mar 2021.xlsx" Night covers are not included in the peak demand savings algorithm because night covers are deployed at night, outside of the peak demand period.

<sup>1466</sup> Based on analysis of Itron eShape data for Missouri, calibrated to Illinois loads, supplied by Ameren. The AC load during the utility's peak hour is divided by the maximum AC load during the year.

$MMBtu_{HVAC\ Heat}$  = Total heating load decrease on the HVAC equipment per linear foot of display case.  
 Varies by locations: <sup>1467</sup>

Zone	$MMBtu_{HVAC\ Heat\ Vertical}$	$MMBtu_{HVAC\ Heat\ Horizontal}$
1 (Rockford)	5.068	0.875
2 (Chicago)	4.937	0.852
3 (Springfield)	4.416	0.762
4 (Belleville)	4.446	0.767
5 (Marion)	4.365	0.753

CL = Case Length, refrigerated case length in feet

= Actual

AFUE = 80%<sup>1468</sup>

10 = Conversion from MMBtu to therms

**WATER IMPACT DESCRIPTIONS AND CALCULATION**

N/A

**DEEMED O&M COST ADJUSTMENT CALCULATION**

N/A

**MEASURE CODE: CI-RFG-DOOR-V02-220101**

**REVIEW DEADLINE: 1/1/2025**

<sup>1467</sup> The MMBtu decrease on the HVAC heating equipment is based on an outdoor air temperature bin analysis, the total hours of operation in which the site is providing heat, and the building's overall reduced heating load as a result of the installation of the doors on the open refrigerated display case. The analysis assumes a certain reduction of conditioned air that had to be treated to make up for the air previously cooled by the display case. The reduced heat gain on the refrigerated display case equals the reduced heat loss by the site and a heating load that no longer has to be provided by the HVAC system.

Furthermore, the analysis assumes a decrease load on the heating system, at outdoor temperatures below 60°F. A 25% disabling factor was also applied to account for some of the cold air pouring out of the display case and subcooling the site's conditioned space, which will not trigger a thermostatic response from the HVAC equipment. For more information on the analysis used to derive the load decrease on the HVAC heating equipment per linear foot of display case, please see the 'HVAC IE' tab in the "IL TRM\_Add Doors\_Analysis\_Mar 2021.xlsx".

<sup>1468</sup> Typical heating system efficiency of 80%, consistent with current heating efficiency assumptions for lighting HVAC interactive effects for commercial fossil fuel-fired systems.

## 4.6.14 Floating Head Pressure Control

### DESCRIPTION

Installers conventionally design a refrigeration system to condense at a set pressure-temperature setpoint, typically 90 degrees. By installing a “floating head pressure control” condenser system, the refrigeration system can change condensing temperatures in response to different outdoor temperatures. This means that as the outdoor temperature drops, the compressor will not have to work as hard to reject heat from the cooler or freezer. This measure is for the application of floating head pressure controls for compressors ≤ 10HP and a condensing temperature set to 70°F. This measure is strictly limited to single compressor systems.

This measure was developed to be applicable to the following program types: RF.

If applied to other program types, the measure savings should be verified. IECC code requires economizers in certain instances and therefore projects relying on code baseline definitions must verify eligibility.

### DEFINITION OF EFFICIENT EQUIPMENT

High efficiency is a refrigeration system with floating head pressure control.

### DEFINITION OF BASELINE EQUIPMENT

The baseline is a refrigeration system without floating head pressure control.

### DEEMED LIFETIME OF EFFICIENT EQUIPMENT

The expected measure life is 15 years<sup>1469</sup>.

### DEEMED MEASURE COST

Floating Head Pressure Control Costs, per Horsepower (condenser rating) are as follows (\$/HP)<sup>1470</sup>:

Unit Type	Low Temperature (Freezer)	Medium Temperature (Refrigerator)	Unknown Temperature <sup>1471</sup>
Self- Contained Unit	\$411.87	\$449.79	\$430.83
Remote Condensing Unit	\$411.87	\$449.79	\$430.83
Unknown <sup>1472</sup>	\$411.87	\$449.79	\$430.83

### LOADSHAPE

Loadshape C22 - Commercial Refrigeration

<sup>1469</sup> California DEER 2014 Effective Useful Life (EUL) table.

<sup>1470</sup> Costs are based on number of additional valves per condenser motor for different HP ratings and includes installation labor costs. Costs are averaged and shown on a per HP basis. See reference document ComGroceryFHPCSingleCompressor\_v2\_1.xlsm, worksheet 'CostData&Analysis,' blue highlighted cells. A comparison of prevailing wages in the Pacific Northwest showed high similarity to Illinois and therefore a simple inflation technique (using the US BLS's CPI Inflation Calculator, comparing the purchasing power of \$1.00 in January 2012 to May 2021) was used to convert 2012\$ to 2021\$ (a multiplier of 1.19).

<sup>1471</sup> Unknown values based on weighted average; 2010 ASHRAE Refrigeration Handbook, page 15.1 “Medium- and low-temperature display refrigerator line-ups account for roughly 68% and 32%, respectively, of a typical supermarket’s total display refrigerators.

<sup>1472</sup> For unit type unknown, it is assumed 50/50 split of self-contained and remote condensing units.

**COINCIDENCE FACTOR**

The summer peak coincidence factor for this measure is assumed to be 0%, based on the fact that savings for this measure will occur during periods of coldest outdoor temperatures.

---

**Algorithm**

---

**CALCULATION OF ENERGY SAVINGS**

**ELECTRIC ENERGY SAVINGS**

$$\Delta kWh = HP * kWh_{HP}$$

Where:

HP = Horsepower of Compressor  
 = actual installed

kWh<sub>HP</sub> = Savings factor, kWh per horsepower of compressor rating. Per the tables below based on weather zone, condensing unit type, and temperature range<sup>1473</sup>:

*Note: Self-contained condensing units assume heat is rejected to conditioned or semi-conditioned space. Therefore, outdoor air temperature is not considered a critical system variable resulting in identical savings across weather zones that are much lower compared to those realized by remove condensing units that reject heat to the outdoor environment.*

Zone 1 (Rockford)

Unit Type	Low Temperature (Freezer)	Medium Temperature (Refrigerator)	Unknown Temperature
Self- Contained Unit	252	131	170
Remote Condensing Unit	482	451	461
Unknown	367	291	315

Zone 2 (Chicago)

Unit Type	Low Temperature (Freezer)	Medium Temperature (Refrigerator)	Unknown Temperature
Self- Contained Unit	252	131	170
Remote Condensing Unit	465	435	445
Unknown	358	283	307

<sup>1473</sup> Derived from RTF saving estimates for the NW climate zone and extrapolated to Illinois climate zones by using heating degree-days for a 65 degree F setpoint as established in Measure 4.4.37 Unitary HVAC Condensing Furnace measure. See reference file "fhp-savings-extrapolation-xlsx-Adjusted for Illinois.xlsx," 2021.

Zone 3 (Springfield)

Unit Type	Low Temperature (Freezer)	Medium Temperature (Refrigerator)	Unknown Temperature
Self- Contained Unit	252	131	170
Remote Condensing Unit	403	377	385
Unknown	327	254	278

Zone 4 (Belleville)

Unit Type	Low Temperature (Freezer)	Medium Temperature (Refrigerator)	Unknown Temperature
Self- Contained Unit	252	131	170
Remote Condensing Unit	321	301	307
Unknown	287	216	239

Zone 5 (Marion)

Unit Type	Low Temperature (Freezer)	Medium Temperature (Refrigerator)	Unknown Temperature
Self- Contained Unit	252	131	170
Remote Condensing Unit	328	307	314
Unknown	290	219	242

**For example**, a low temperature remote condensing unit in Chicago (Zone 2) with a 3-horsepower condenser would annually save:

$$\Delta\text{kWh} = 3 * 465$$

$$= 1,395 \text{ kWh}$$

**SUMMER COINCIDENT PEAK DEMAND SAVINGS**

There are no expected summer coincident peak demand savings for this measure.

**FOSSIL FUEL IMPACT DESCRIPTIONS AND CALCULATIONS**

There are no expected fossil fuel gas savings for this measure.

**WATER IMPACT DESCRIPTIONS AND CALCULATION**

N/A

**DEEMED O&M COST ADJUSTMENT CALCULATION**

N/A

**MEASURE CODE: CI-RFG-FHP-V01-220101**

**REVIEW DEADLINE: 1/1/2026**

## 4.7. Compressed Air

### 4.7.1 VSD Air Compressor

#### DESCRIPTION

This measure relates to the installation of an air compressor with a variable frequency drive, load/no-load controls or variable displacement control. Baseline compressors choke off the inlet air to modulate the compressor output, which is not efficient. Efficient compressors use a variable speed drive on the motor to match output to the load. Savings are calculated using representative baseline and efficient demand numbers for compressor capacities according to the facility's load shape, and the number of hours the compressor runs at that capacity. Demand curves are as per DOE data for a Variable Speed compressor versus a Modulating compressor. This measure applies only to an individual compressor  $\leq 200$  hp. Only one compressor per compressed air distribution system is eligible.

This measure was developed to be applicable to the following program types: TOS.

If applied to other program types, the measure savings should be verified.

#### DEFINITION OF EFFICIENT EQUIPMENT

The high efficiency equipment is a compressor  $\leq 200$  hp with variable speed control.

#### DEFINITION OF BASELINE EQUIPMENT

The baseline equipment is either an oil-flooded compressor  $\leq 200$  hp with inlet modulating with blowdown or load/no-load controls.

#### DEEMED LIFETIME OF EFFICIENT EQUIPMENT

13 years<sup>1474</sup>

#### DEEMED MEASURE COST

$$\text{IncrementalCost } (\$) = ((127 \times \text{hp}_{\text{compressor}}) + 1,446) \times 1.24^{1475}$$

Where:

127 and 1,446<sup>1476</sup> = compressor motor nominal hp to incremental cost conversion factor and offset

$\text{hp}_{\text{compressor}}$  = compressor motor nominal

#### DEEMED O&M COST ADJUSTMENTS

N/A

#### LOADSHAPE

Loadshape C35 - Industrial Process

---

<sup>1474</sup> Department of Energy Technical Support Document.

<sup>1475</sup> Adjustment for inflation since incremental cost study is in \$2008. The U.S. Bureau of Labor Statistic CPI Inflation Calculator was used to adjust \$2008 (January) to \$2021 (January). The resulting factor was 1.24. This adjustment was evaluated against current pricing of compressors (2021) and found to be a reasonable and appropriate.

<sup>1476</sup> Conversion factor and offset based on a linear regression analysis of the relationship between air compressor motor nominal horsepower and incremental cost, as sourced from the Efficiency Vermont Technical Reference Manual (TRM). Several Vermont vendors were surveyed to determine the cost of equipment.



**COINCIDENCE FACTOR**

The summer peak coincidence factor for this measure is dependent on the industrial shift and corresponding hours of operation. Values are provided for each shift type in the variable definition section.

**Algorithm**

**CALCULATION OF SAVINGS**

**ELECTRIC ENERGY SAVINGS**

$$\Delta kWh = 0.9 \times hp_{\text{compressor}} \times \text{HOURS} \times (CF_b - CF_e)$$

Where:

- $\Delta kWh$  = gross customer annual kWh savings for the measure
- $hp_{\text{compressor}}$  = compressor motor nominal hp
- $0.9^{1477}$  = compressor motor nominal hp to full load kW conversion factor
- HOURS = compressor total hours of operation below depending on shift

Shift	Hours	Description
Single shift (8/5)	1,976	7 AM – 3 PM, weekdays, minus some holidays and scheduled down time
2-shift (16/5)	3,952	7AM – 11 PM, weekdays, minus some holidays and scheduled down time
3-shift (24/5)	5,928	24 hours per day, weekdays, minus some holidays and scheduled down time
4-shift (24/7)	8,320	24 hours per day, 7 days a week minus some holidays and scheduled down time
Unknown / Weighted average <sup>1478</sup>	5,702	

- $CF_b$  = baseline compressor factor<sup>1479</sup>

<sup>1477</sup> Conversion factor based on Survey of CAGI data sheets from 200 compressors. See “IL TRM VSD Air Compressor – Supporting Information.xls” for more information.

<sup>1478</sup> Weighting of 16% single shift, 23% two shift, 25% three shift and 36% continual based on DOE evaluation of the Compressed Air Challenge, section 2.1.5 Facility Operating Schedules.

<sup>1479</sup> Compressor factors were developed using DOE part load data for different compressor control types as well as load profiles from 50 facilities employing air compressors less than or equal to 40 hp, as sourced from the Efficiency Vermont TRM.(The “variable speed drive” compressor factor has been adjusted up from the 0.675 presented in the analysis to 0.705 to account for the additional power draw of the VSD).

Baseline Compressor	Compressor Factor (≤ 40 hp) <sup>1480</sup>	Compressor Factor (50 – 200 hp) <sup>1481</sup>
Modulating w/ Blowdown	0.890	0.863
Load/No-Load w/ 1 Gallon/CFM	0.909	0.887
Load/No-Load w/ 3 Gallon/CFM	0.831	0.811
Load/No-Load w/ 5 Gallon/CFM	0.806	0.786

CF<sub>e</sub> = efficient compressor  
 = 0.705 for units ≤ 40 hp<sup>1482</sup>  
 = 0.658 for units 50 – 200 hp

**For example**, a VSD compressor with 10 hp operating in a 1-shift facility would save

ΔkWh = 0.9 x 10 x 1,976 x (0.890 – 0.705)  
 = 3,290 kWh

**SUMMER COINCIDENT PEAK DEMAND SAVINGS**

ΔkW = ΔkWh / HOURS \* CF

Where:

CF = Summer peak coincidence factor for this measure

Shift	Coincidence Factor
Single shift (8/5)	0.59
2-shift (16/5)	0.95
3-shift (24/5)	0.95
4-shift (24/7)	0.95
Unknown / Weighted average <sup>1484</sup>	0.89

<sup>1480</sup> Compressor factors were developed using DOE part load data for different compressor control types as well as load profiles from 50 facilities employing air compressors less than or equal to 40 hp, as sourced from the Efficiency Vermont TRM. (The “variable speed drive” compressor factor has been adjusted up from the 0.675 presented in the analysis to 0.705 to account for the additional power draw of the VSD). See “IL TRM VSD Air Compressor – Supporting Information.xls” for more information.

<sup>1481</sup> Compressor factors for this size range were developed using DOE part-load data for different compressor control types as well as load profiles from 45 compressors and 20 facilities. This data comes from ComEd Custom and Industrial Systems programs. The compressors were filtered to reflect only rotary screw compressors, between 50 and 200 hp, and operating a minimum of 4 hour per day. Additionally, compressors with clear and consistent baseload profiles were excluded from this analysis. See “IL TRM VSD Air Compressor – Supporting Information.xls” for more information.

<sup>1482</sup> Compressor factors were developed using DOE part load data for different compressor control types as well as load profiles from 50 facilities employing air compressors less than or equal to 40 hp, as sourced from the Efficiency Vermont TRM.(The “variable speed drive” compressor factor has been adjusted up from the 0.675 presented in the analysis to 0.705 to account for the additional power draw of the VSD). See “IL TRM VSD Air Compressor – Supporting Information.xls” for more information.

<sup>1483</sup> Compressor factors for this size range were developed using DOE part-load data for different compressor control types as well as load profiles from 45 compressors and 20 facilities. This data comes from ComEd Custom and Industrial Systems programs. The compressors were filtered to reflect only rotary screw compressors, between 50 and 200 hp, and operating a minimum of 4 hour per day. Additionally, compressors with clear and consistent baseload profiles were excluded from this analysis. See “IL TRM VSD Air Compressor – Supporting Information.xls” for more information.

<sup>1484</sup> Ibid.

**For example**, a VSD compressor with 10 HP operating in a 1 shift facility would save

$$\begin{aligned}\Delta kW &= 3,290/1,976*0.59 \\ &= 0.98 \text{ kW}\end{aligned}$$

**FOSSIL FUEL SAVINGS**

N/A

**WATER IMPACT DESCRIPTIONS AND CALCULATION**

N/A

**DEEMED O&M COST ADJUSTMENT CALCULATION**

N/A

**MEASURE CODE: CI-CPA-VSDA-V04-220101**

**REVIEW DEADLINE: 1/1/2027**

## 4.7.2 Compressed Air Low Pressure Drop Filters

### DESCRIPTION

Low pressure drop filters remove solids and aerosols from compressed air systems with a longer life and lower pressure drop than standard coalescing filters, resulting in the ability to lower a compressed air systems pressure setpoints. This reduces the compressor work required resulting in energy savings.

This measure was developed to be applicable to the following program types: RF. If applied to other program types, the measure savings should be verified.

### DEFINITION OF EFFICIENT EQUIPMENT

The efficient condition is a low pressure drop filter with pressure drop not exceeding 1 psid when new and 3 psid at element change.

### DEFINITION OF BASELINE EQUIPMENT

The baseline condition is a standard coalescing filter with a pressure drop of 3 psid when new and 5 psid or more at element change

### DEEMED LIFETIME OF EFFICIENT EQUIPMENT

10 years <sup>1485</sup>

### DEEMED MEASURE COST

The incremental cost for this measure is estimated to be \$1,000 Incremental cost per filter. <sup>1486</sup>

### LOADSHAPE

Loadshape C35 - Industrial Process

### COINCIDENCE FACTOR

The summer peak coincidence factor for this measure is dependent on the industrial shift and corresponding hours of operation. Values are provided for each shift type in the variable definition section.

---



---

### Algorithm

---

### CALCULATION OF SAVINGS

#### ELECTRIC ENERGY SAVINGS

$$\Delta kWh = (kW_{\text{typical}} \times \Delta P \times SF \times \text{Hours} / hp_{\text{typical}}) \times hp_{\text{real}}$$

Where:

$kW_{\text{typical}}$  = Adjusted compressor power (kW) based on typical compressor loading and operating profile. Use actual compressor control type if known:

---

<sup>1485</sup> Based on survey of manufacturer claims (Zeks, Van Air, Quincy), as recommended in Navigant 'ComEd Effective Useful Life Research Report', May 2018.

<sup>1486</sup> Incremental cost research found in LPDF Costs. xlsx.

Compressor kW<sub>typical</sub>

Control Type	kW <sub>typical</sub> <sup>1487</sup>
Reciprocating - On/off Control	70.2
Reciprocating - Load/Unload	74.8
Screw - Load/Unload	82.3
Screw - Inlet Modulation	82.5
Screw - Inlet Modulation w/ Unloading	82.5
Screw - Variable Displacement	73.2
Screw - VFD	70.8

= If the actual compressor control type is not known, use a weighted average based on the following market assumptions:

Control Type	Share %	kW <sub>typical</sub> <sup>1488</sup>
Market share estimation for load/unload control compressors	40%	74.8
Market share estimation for modulation w/unloading control compressors	40%	82.5
Market share estimation for variable displacement control compressors	20%	73.2
Weight average	-	77.6

$\Delta P$  = Reduction in pressure differential across the filter (psi)

=2 psi<sup>1489</sup>

SF =1% reduction in power per 2 psi reduction in system pressure is equal to 0.5% reduction per 1 psi, or a Savings Factor of 0.005<sup>1490</sup>

Hours = Compressor hours of operation below depending on shift

Shift	Hours	Description
Single shift (8/5)	1,976	7 AM – 3 PM, weekdays, minus three-weekday holidays and 10 days of scheduled down time
2-shift (16/5)	3,952	7AM – 11 PM, weekdays, minus three-weekday holidays and 10 days of scheduled down time
3-shift (24/5)	5,928	24 hours per day, weekdays, minus three-weekday holidays and 10 days of scheduled down time
4-shift (24/7)	8,320	24 hours per day, 7 days a week minus three-week day holidays and 10 days of scheduled down time
Unknown / Weighted average <sup>1491</sup>	5,702	

hp<sub>typical</sub> = Nominal hp for typical compressor = 100 hp<sup>1492</sup>

<sup>1487</sup> See “Industrial System Standard Deemed Saving Analysis.xls”.

<sup>1488</sup> See “Industrial System Standard Deemed Saving Analysis.xls”.

<sup>1489</sup> Assumed pressure will be reduced from a roughly 3 psi pressure drop through a filter to less than 1 psi, for a 2 psi savings

<sup>1490</sup> “Optimizing Pneumatic Systems for Extra Savings,” Compressed Air Best Practices, DOE Compressed Air Challenge, 2010.

<sup>1491</sup> Weighting of 16% single shift, 23% two shift, 25% three shift and 36% continual based on DOE evaluation of the Compressed Air Challenge, section 2.1.5 Facility Operating Schedules.

<sup>1492</sup> Industrial System Standard Deemed Saving Analysis.xls

$hp_{real}$  = Total hp of real compressors distributing air through filter. This should include the total horsepower of the compressors that normally run through the filter, but not backup compressors.

**SUMMER COINCIDENT PEAK DEMAND SAVINGS**

$$\Delta kW = \Delta kWh / \text{Hours} * CF$$

Where:

CF = Summer peak coincidence factor for this measure

Shift	Coincidence Factor
Single shift (8/5)	0.59
2-shift (16/5)	0.95
3-shift (24/5)	0.95
4-shift (24/7)	0.95
Unknown / Weighted average <sup>1493</sup>	0.89

**FOSSIL FUEL SAVINGS**

N/A

**WATER IMPACT DESCRIPTIONS AND CALCULATION**

N/A

**DEEMED O&M COST ADJUSTMENT CALCULATION**

N/A

**MEASURE CODE: CI-CPA-LPDF-V04-220101**

**REVIEW DEADLINE: 1/1/2027**

---

<sup>1493</sup> Weighting of 16% single shift, 23% two shift, 25% three shift and 36% continual based on DOE evaluation of the Compressed Air Challenge, section 2.1.5 Facility Operating Schedules.

### 4.7.3 Compressed Air No-Loss Condensate Drains

**DESCRIPTION**

No-loss condensate drains remove condensate as needed without venting compressed air, resulting in less air demand and consequently better efficiency. Replacement or upgrades of existing no-loss drains are not eligible for the incentive.

This measure was developed to be applicable to the following program types: RF. If applied to other program types, the measure savings should be verified

**DEFINITION OF EFFICIENT EQUIPMENT**

The efficient condition is installation of no-loss condensate drains.

**DEFINITION OF BASELINE EQUIPMENT**

The baseline condition is installation of standard condensate drains (open valve, timer, or both)

**DEEMED LIFETIME OF EFFICIENT EQUIPMENT**

10 years

**DEEMED MEASURE COST**

The average equipment cost per drain is \$194 with an installation labor cost of \$50 for a total incremental cost \$244 per drain.<sup>1494</sup>

**LOADSHAPE**

Loadshape C35 - Industrial Process

**COINCIDENCE FACTOR**

The coincidence factor equals 0.95.<sup>1495</sup>

---



---

**Algorithm**

---

**CALCULATION OF SAVINGS**

**ELECTRIC ENERGY SAVINGS**

$$\Delta kWh = CFM_{reduced} \times kW_{CFM} \times \text{Hours}$$

Where:

$$CFM_{reduced} = \text{Reduced air consumption (CFM) per drain}$$

$$= 3 \text{ CFM}^{1496}$$

$$kW_{CFM} = \text{System power reduction per reduced air demand (kW/CFM) depending on the type of compressor control:}$$

---

<sup>1494</sup> Based on empirical project data from ComEd Comprehensive Compressed Air Study program and VEIC review of pricing data found in CAS Cost Data.xlsx.

<sup>1495</sup> Efficiency Vermont Technical Reference Manual (TRM) Measure Savings Algorithms and Cost Assumptions, August 10, 2016.

<sup>1496</sup> Reduced CFM consumption is based on a timer drain opening for 10 seconds every 300 seconds as the baseline. See “Industrial System Standard Deemed Saving Analysis.xls”.

System Power Reduction per Reduced Air Demand<sup>1497</sup>

Control Type	kW / CFM
Reciprocating - On/off Control	0.184
Reciprocating - Load/Unload	0.136
Screw - Load/Unload	0.152
Screw - Inlet Modulation	0.055
Screw - Inlet Modulation w/ Unloading	0.055
Screw - Variable Displacement	0.153
Screw - VFD	0.178

Or if compressor control type is unknown, then a weighted average based on market share can be used:<sup>1498</sup>

Control Type	Share %	kW / CFM
Market share estimation for load/unload control compressors	40%	0.136
Market share estimation for modulation w/unloading control compressors	40%	0.055
Market share estimation for variable displacement control compressors	20%	0.153
Weighted Average		0.107

Hours = Compressed air system pressurized hours  
 =6136 hours<sup>1499</sup>

**SUMMER COINCIDENT PEAK DEMAND SAVINGS**

$\Delta kW = \Delta kWh / HOURS * CF$

Where:

CF = Summer peak coincidence factor for this measure  
 = 0.95

**FOSSIL FUEL SAVINGS**

N/A

**WATER IMPACT DESCRIPTIONS AND CALCULATION**

N/A

**DEEMED O&M COST ADJUSTMENT CALCULATION**

N/A

<sup>1497</sup> Calculated based on the type of compressor control. This assumes the compressor will be between 40% and 100% capacity before and after the changes to the system demand. See "Industrial System Standard Deemed Saving Analysis.xls".

<sup>1498</sup> Table 8.2.3, Technical Support Document. US Department of Energy

<sup>1499</sup> US DOE, Evaluation of the Compressed Air Challenge® Training Program, Page 19.



**MEASURE CODE: CI-CPA-NCLD-V03-200101**

**REVIEW DEADLINE: 1/1/2025**

## 4.7.4 Efficient Compressed Air Nozzles

### DESCRIPTION

This measure is for the replacement of a standard air nozzle with a high-efficiency air nozzle used in a compressed air system. High-efficiency air nozzles reduce the amount of air required to blow off parts or for drying. These nozzles utilize the Coandă effect to pull in free air to accomplish tasks with significantly less compressed air. High-efficiency nozzles often replace simple copper tubes. These nozzles have the added benefits of noise reduction and improved safety in systems with greater than 30 psig.

### DEFINITION OF EFFICIENT EQUIPMENT

The high-efficiency air nozzle must meet the following specifications:

1. High-efficiency air nozzle must replace continuous open blow-offs.
2. High-efficiency air nozzle must meet SCFM rating at 80psig less than or equal to:

Nozzle Diameter:	1/8"	1/4"	5/16"	1/2"
Max SCFM Rating @ 80psig:	11	29	56	140

3. Manufacturer's specification sheet of the high-efficiency air nozzle must be provided along with the make and model.

### DEFINITION OF BASELINE EQUIPMENT

The baseline condition is a standard air nozzle.

### DEEMED LIFETIME OF EFFICIENT EQUIPMENT

The measure life is 15 years.<sup>1500</sup>

### DEEMED MEASURE COST

The estimated incremental measure costs are presented in the following table:<sup>1501</sup>

Nozzle Diameter:	1/8"	1/4"	5/16"	1/2"
Average Incremental Cost:	\$42	\$57	\$87	\$121

### LOADSHAPE

Loadshape C35 - Industrial Process

### COINCIDENCE FACTOR

The summer peak coincidence factor for this measure is dependent on the industrial shift and corresponding hours of operation. Values are provided for each shift type in the variable definition section.

<sup>1500</sup> PA Consulting Group (2009). Business Programs: Measure Life Study. Prepared for State of Wisconsin Public Service Commission.

<sup>1501</sup> Costs are from EXAIR's website and are an average of nozzles that meet the flow requirements. Models include Atto Super, Pico Super, Nano Super, Micro Super, Mini Super, Super and Large Super nozzles. Accessed March 20, 2014.

**Algorithm**

**CALCULATION OF ENERGY SAVINGS**

**ELECTRIC ENERGY SAVINGS**

$$\Delta kWh = (SCFM * SCFM\%Reduced) * kW/CFM * \%USE * Hours$$

Where:

SCFM = Air flow through standard nozzle. Use actual rated flow at 80 psi if known. If unknown, the table below includes the CFM by orifice diameter.<sup>1502, 1503</sup>

Orifice Diameter	SCFM
1/8"	21
1/4"	58
5/16"	113
1/2"	280

SCFM%Reduced = Percent in reduction of air loss per nozzle. Estimated at 50%.<sup>1504</sup>

kW/CFM = System power reduction per air demand (kW/CFM) depending on the type of air compressor found in table below:<sup>1505</sup>

Air Compressor Type	kW/CFM
Reciprocating – On/off Control	0.18
Reciprocating – Load/Unload	0.14
Screw – Load/Unload	0.15
Screw – Inlet Modulation	0.06
Screw – Inlet Modulation w/ Unloading	0.06
Screw – Variable Displacement	0.15
Screw - VFD	0.18

%USE = Percent of the compressor’s total operating hours that the nozzle is in use.  
 = Custom. If unknown assume 5%.<sup>1506</sup>

Hours = Compressed air system pressurized hours.  
 = Use actual hours if known. Otherwise assume values in table below:

<sup>1502</sup> Review of manufacturer’s information.

<sup>1503</sup> Technical Reference Manual (TRM) for Ohio Senate Bill 221 “Energy Efficiency and Conservation Program” and 09-512-GE-UNC, October 15, 2009. Pages 170-171.

<sup>1504</sup> Conservative estimate based on average values provided by the Compressed Air Challenge Training Program, Machinery’s Handbook 25<sup>th</sup> Edition, and manufacturers’ catalog.

<sup>1505</sup> Calculated based on the type of compressor control. This assumes the compressor will be between 40% and 100% capacity before and after the changes to the system demand. See “Industrial System Standard Deemed Saving Analysis.xls”.

<sup>1506</sup> Assumes 50% handheld air guns and 50% stationary air nozzles. Manual air guns tend to be used less than stationary air nozzles, and a conservative estimate of 1 second of blow-off per minute of compressor run time is assumed. Stationary air nozzles are commonly more wasteful as they are often mounted on machine tools and can be manually operated resulting in the possibility of a long term open blow situation. An assumption of 5 seconds of blow-off per minute of compressor run time is used.

Shift	Hours
Single Shift	1,976
Two Shifts	3,952
Three Shifts	5,928
Four Shifts or Continual Operation	8,320
Unknown / Weighted average <sup>1507</sup>	5,702

**SUMMER COINCIDENT PEAK DEMAND SAVINGS**

$$\Delta kW = \Delta kWh / \text{Hours} * CF$$

Where:

$\Delta kWh$  = As calculated above.

CF = Summer peak coincidence factor

Shift	Coincidence Factor
Single Shift	0.59
Two Shifts	0.95
Three Shifts	0.95
Four Shifts or Continual Operation	0.95
Unknown / Weighted average <sup>1508</sup>	0.89

**FOSSIL FUEL SAVINGS**

N/A

**WATER IMPACT DESCRIPTIONS AND CALCULATION**

N/A

**DEEMED O&M COST ADJUSTMENT CALCULATION**

N/A

**MEASURE CODE CI-CPA-CNOZ-V03-230101**

**REVIEW DEADLINE: 1/1/2027**

<sup>1507</sup> Weighting of 16% single shift, 23% two shift, 25% three shift and 36% continual based on DOE evaluation of the Compressed Air Challenge, section 2.1.5 Facility Operating Schedules.

<sup>1508</sup> Ibid.

## 4.7.5 Efficient Refrigerated Compressed Air Dryer

### DESCRIPTION

An air dryer is an essential component in a compressed air system that prevents condensate from being deposited in the compressed air supply lines of a facility. If warm saturated compressed air is supplied directly to the plant, excess condensate will form in the compressed air supply lines. Uncontrolled condensate can damage demand-side tools and process equipment. Secondly, in an oil-flooded rotary screw compressor, the residual oil from compression can be carried along the supply lines potentially damaging process equipment. Industries that use compressed air for processes make use of various types of dryers including refrigerated dryers (both cycling and non-cycling). For this measure, three types of refrigerated air dryers will be considered: thermal mass, variable speed, and digital scroll. All these technologies offer better part load performance compared to non-cycling refrigerated dryers, thereby offering energy savings during periods when the dryer is not operating at peak capacity.

This measure was developed to be applicable to the following program types: TOS.

If applied to other program types, the measure savings should be verified.

### DEFINITION OF EFFICIENT EQUIPMENT

A new, high efficiency thermal mass dryer, variable speed dryer, or digital scroll dryer.

### DEFINITION OF BASELINE EQUIPMENT

A standard non-cycling refrigerated compressed air dryer of comparable capacity.

### DEEMED LIFETIME OF EFFICIENT EQUIPMENT

The measure life is 13 years.<sup>1509</sup>

### DEEMED MEASURE COST

The incremental capital cost for this measure is \$6 per CFM.<sup>1510</sup>

### LOADSHAPE

Loadshape C35 – Industrial Process

### COINCIDENCE FACTOR

The summer peak coincidence factor for this measure is dependent on the industrial shift and corresponding hours of operation. Values are provided for each shift type in the variable definition section.

---



---

### Algorithm

---

### CALCULATION OF SAVINGS

#### ELECTRIC ENERGY SAVINGS

$$\Delta kWh = P_s * (EC50_{baseline} - EC50_{efficient}) * HOURS * CFM$$

Where:

$$P_s = \text{Full flow specific power of the dryer}$$

---

<sup>1509</sup> As recommended in Navigant 'ComEd Effective Useful Life Research Report', May 2018.

<sup>1510</sup> Analysis of material cost between cycling and non-cycling dryers according to online prices from Grainger. Cost provided is the average incremental cost when comparing non-cycling and cycling dryers of the same CFM capacity.

= 0.007 kW/CFM<sup>1511</sup> (for both baseline and efficient equipment)

EC50<sub>baseline</sub> = Energy consumption ratio of baseline dryer at 50%<sup>1512</sup> inlet load capacity as compared to fully loaded operating conditions.<sup>1513</sup>  
 = 0.843

ECF50<sub>efficient</sub> = Energy consumption ratio of efficient dryer at 50% inlet load capacity as compared to fully loaded operating conditions.  
 = Dependent on efficient dryer type, refer to the following table:<sup>1514</sup>

Dryer Type	EC50 <sub>efficient</sub>
Thermal-Mass	0.729
VSD	0.501
Digital Scroll	0.551

HOURS = Compressed air system pressurized hours, depending on shift. If unknown, use weighted average. This value is the weighted average of facility owner responses from the DOE evaluation of the Compressed Air Challenge. Facility owners with compressed air systems were surveyed detailing the number of shifts their facilities operated.

Shift	Shift	Hours	Distribution of Facilities by Hours of Operation <sup>1515</sup>	Weighted Hours
Single Shift	7 AM – 3 PM, weekdays, minus some holidays and scheduled down time	1,976	16%	316
Two Shift	7AM – 11 PM, weekdays, minus some holidays and scheduled down time	3,952	23%	909
Three Shift	24 hours per day, weekdays, minus some holidays and scheduled down time	5,928	25%	1,482
Four Shifts or Continual Operation	24 hours per day, 7 days a week minus some holidays and scheduled down time	8,320	36%	2,995
			<b>Total Weighted Average:</b>	<b>5,702</b>

CFM = Cubic feet per minute, rated capacity of refrigerated dryer  
 = Assume 100% of actual rated capacity.

**SUMMER COINCIDENT PEAK DEMAND SAVINGS**

$$\Delta kW = \Delta kWh / \text{HOURS} * CF$$

Where:

<sup>1511</sup> Compressed Air Challenge: Compressed Air Best Practice; “Cycling Air Dryers – Are Savings Significant?” Fox, Timothy J. and Marshall, Ron.

<sup>1512</sup> Engineering judgement, based on the assumption that on average, compressed air systems will operate at 50% capacity.

<sup>1513</sup> Compressed Air Challenge: Compressed Air Best Practice; “Cycling Air Dryers – Are Savings Significant?” Fox, Timothy J. and Marshall, Ron.

<sup>1514</sup> Compressed Air Challenge: Compressed Air Best Practice; “Cycling Air Dryers – Are Savings Significant?” Fox, Timothy J. and Marshall, Ron.

<sup>1515</sup> DOE evaluation of the Compressed Air Challenge, section 2.1.5 Facility Operating Schedules.

CF = Summer peak coincidence factor, depending on shift. If unknown, use weighted average.

Shift	Coincidence Factor
Single Shift	0.59
Two Shifts	0.95
Three Shifts	0.95
Four Shifts or Continual Operation	0.95
Unknown / Weighted average <sup>1516</sup>	0.89

**FOSSIL FUEL SAVINGS**

N/A

**WATER IMPACT DESCRIPTIONS AND CALCULATION**

N/A

**DEEMED O&M COST ADJUSTMENT CALCULATION**

N/A

**MEASURE CODE: CI-CPA-CADR-V03-240101**

**REVIEW DEADLINE: 1/1/2028**

---

<sup>1516</sup> Weighting of 16% single shift, 23% two shift, 25% three shift and 36% continual based on DOE evaluation of the Compressed Air Challenge, section 2.1.5 Facility Operating Schedules.

4.7.6 Vortex Tube Thermostat - PROVISIONAL MEASURE – Retired 12/31/2023, Removed in  
v12



## 4.7.7 Efficient Desiccant Compressed Air Dryer

### DESCRIPTION

Compressed air is dried to reduce or eliminate condensation that can harm the compressed air system or end use equipment. For applications that require air to be dried below a dew point of 35°F,<sup>1517</sup> regenerative desiccant air dryers are typically used. Typically, regenerative desiccant dryers achieve pressure dew points as low as -40°F.

Regenerative desiccant dryers generally consist of two towers (or vertical tanks) filled with porous desiccant media. “Wet” compressed air flows through one tower, exiting as dried compressed air, while the other tower is dried out (or regenerated). This dryer alternates this process between towers to prevent compressed air flowing through saturated towers and damaging downstream equipment. The means of regeneration distinguishes the different types of regenerative dryer.

Heatless Desiccant Dryer: Uses compressed air (“purge air”) to dry out the regenerating tower. The amount of purge air is typically between 15-20% of the dryer’s rate flow (CFM), regardless of the flow rate that the compressor is supplying.<sup>1518</sup> This type of dryer alternates tower regeneration approximately every 5 minutes.<sup>1519</sup>

Heated Desiccant Dryer: Uses a combination of compressed purge air and heat for regeneration. The amount of purge air is typically 5-10% of the dryer’s rate flow (CFM), regardless of the flow rate that the compressor is supplying.<sup>1520</sup> This type of dryer alternates tower regeneration approximately every 8 hours.<sup>1521</sup>

Externally Heated Blower Purge Dryer: Uses an external blower and heat source for regeneration. This type of dryer requires a small amount (2%) of purge air or ambient air to cool the tower after heating. This type of dryer alternates tower regeneration approximately every 8 hours.<sup>1522</sup> There is also a type of blower purge dryer called a zero-purge dryer that eliminates all compressed purge air.

The energy use of these dryers is primarily due to regeneration of the desiccant. Standard dryers come equipped with a fixed, timer regeneration control. However, the actual load on the dryer is variable. Optional dew point demand controls (DPDC) adjust the amount of regeneration to the moisture load on the dryer, reducing unnecessary purge energy.

This measure was developed to be applicable to the following program types: TOS, NC, ER.

### DEFINITION OF EFFICIENT EQUIPMENT

The efficient equipment is heated or externally heated by a blower purge desiccant dryer without dew point demand controls. Dryers installed on inlet modulation compressors do not qualify for this measure.

<sup>1517</sup> The dew point limitation of the most common refrigerant-type air dryer. Improving Compressed Air System Performance: A Sourcebook for Industry, US Department of Energy. Page 48.

<https://www.energy.gov/sites/prod/files/2016/03/f30/Improving%20Compressed%20Air%20Sourcebook%20version%203.pdf>

<sup>1518</sup> Lessons Learned: Saving Energy Costs with Heated Blower Purge Desiccant Dryers, Marshall, Ron.

<https://airbestpractices.com/system-assessments/air-treatment2/lessons-learned-saving-energy-costs-heated-blower-desiccant-dry-0>

<sup>1519</sup> Regenerative Desiccant Compressed Air Dryers. White, Donald. <https://airbestpractices.com/technology/air-treatment2/regenerative-desiccant-compressed-air-dryers>

<sup>1520</sup> Types of Compressed Air Dryers 2: Refrigerant and Regenerative Desiccant, Compressed Air and Gas Institute (CAGI). <https://airbestpractices.com/technology/air-treatment/n2/types-compressed-air-dryers-refrigerant-and-regenerative-desiccant>

<sup>1521</sup> Regenerative Desiccant Compressed Air Dryers. White, Donald. <https://airbestpractices.com/technology/air-treatment2/regenerative-desiccant-compressed-air-dryers>

<sup>1522</sup> Regenerative Desiccant Compressed Air Dryers. White, Donald. <https://airbestpractices.com/technology/air-treatment2/regenerative-desiccant-compressed-air-dryers>

**DEFINITION OF BASELINE EQUIPMENT**

The baseline equipment is a heatless regenerative desiccant dryer without dew point demand controls.

**DEEMED LIFETIME OF EFFICIENT EQUIPMENT**

The lifetime of this measure is 15 years.<sup>1523</sup>

**DEEMED MEASURE COST**

The incremental equipment cost for heated and blower purge regenerative desiccant dryers is \$3/CFM and \$12/CFM, respectively.<sup>1524</sup>

**LOADSHAPE**

Loadshape C35 – Industrial Process

**COINCIDENCE FACTOR**

The summer peak coincidence factor for this measure is dependent on the industrial shift and corresponding hours of operation. Values are provided for each shift type in the variable definition section.

---

**Algorithm**

---

**CALCULATION OF ENERGY SAVINGS**

**ELECTRIC ENERGY SAVINGS**

$$\Delta kWh = CFM_{Dryer} * (P_{Base} - P_{EE} * PRF) * HOU$$

Where:

CFM<sub>Dryer</sub> = rated capacity of the dryer in cubic feet per minute (CFM)

P<sub>Base</sub> = power requirement of the baseline heatless regenerative dryer (kW/CFM)  
 = PF<sub>Heatless</sub> \* kW<sub>comp</sub>

PF<sub>Heatless</sub> = purge flow of heatless model (%)  
 = 15%<sup>1525</sup>

kW<sub>comp</sub> = system power reduction per reduced air demand (kW/CFM) depending on the type of compressor control.<sup>1526</sup> If unknown, assume Screw – Load/Unload.

Air Compressor Type	ΔkW/CFM
Reciprocating – On/off Control	0.18
Reciprocating – Load/Unload	0.14
Screw – Load/Unload	0.15
Screw – Variable Displacement	0.15

<sup>1523</sup> Focus on Energy Evaluation Business Programs: Measure Life Study, p. 91-92. PA Consulting Group. August 25, 2009. [https://focusonenergy.com/sites/default/files/bpmeasurelifestudyfinal\\_evaluationreport.pdf](https://focusonenergy.com/sites/default/files/bpmeasurelifestudyfinal_evaluationreport.pdf)

<sup>1524</sup> Analysis of equipment cost between heatless, heated, blower purge dryers according to available online pricing. The capacity range considered was 250 – 1,500 CFM. Cost provided is the average incremental cost when comparing heated and blower purge dryers to baseline heatless dryers of the same CFM capacity. See “IL TRM Deissciant Dryers – Supporting Information.xls” file for more detail.

<sup>1525</sup> Typical estimates of purge flow for heatless dryers range from 15-20% of dryer rated capacity. 15% was selected as a conservative value.

<sup>1526</sup> Consistent with Air Nozzle measure, this assumes the compressor will be between 40% and 100% capacity before and after the changes to the system demand. See “Industrial System Standard Deemed Saving Analysis.xls”.

Air Compressor Type	$\Delta kW/CFM$
Screw - VFD	0.18

Note: Dryers installed on inlet modulation compressors do not qualify for this measure.

- $P_{EE}$  = power requirement of the energy efficient (heated or blower purge) regenerative dryer (kW/CFM)  
 =  $(PF_{EE} * kW_{comp} + kW_{Heater} + kW_{Blower})$
- $PF_{EE}$  = purge flow of energy efficient model (%)<sup>1527</sup>  
 = 7.5% for heated models  
 = 2% for blower purge models (with compressed air cooling)  
 = 0% for “zero-purge” blower purge models
- $kW_{Heater}$  = average power of heater per CFM of dryer (kW/CFM)<sup>1528, 1529</sup>  
 = 0.007 kW/CFM for heated models  
 = 0.013 kW/CFM for blower purge models
- $kW_{Blower}$  = average power of blower per CFM of dryer (kW/CFM)<sup>1530</sup>  
 = 0 kW/CFM for heated models  
 = 0.003 kW/CFM for blower purge models
- PRF = purge reduction factor  
 = Assume 50% for heatless desiccant dryers%<sup>1531</sup>  
 = Assume 60% for externally heated or heated blower purge desiccant dryers<sup>1532</sup>
- HOU = compressor total hours of operation below depending on shift

<sup>1527</sup> Lessons Learned: Saving Energy Costs with Heated Blower Purge Desiccant Dryers, Marshall, Ron. <https://airbestpractices.com/system-assessments/air-treatment2/lessons-learned-saving-energy-costs-heated-blower-desiccant-dry-0>

<sup>1528</sup> Based on a review of data sheets from six manufacturers. These values reflect average heater kW and not nominal heater kW. The heater operation will vary based on moisture load to the dryer. See “IL TRM Desiccant Dryers – Supporting Information.xls” file for more detail.

<sup>1529</sup> The heater operation will be controlled by temperature to avoid overheating the desiccant media. Lessons Learned: Saving Energy Costs with Heated Blower Purge Desiccant Dryers, Marshall, Ron. <https://airbestpractices.com/system-assessments/air-treatment2/lessons-learned-saving-energy-costs-heated-blower-desiccant-dry-0>

<sup>1530</sup> Based on a review of data sheets from six manufacturers. These values reflect average blower kW and not nominal blower kW. The blower operation will in many cases vary based on moisture load to the dryer. See “IL TRM Desiccant Dryers – Supporting Information.xls” file for more detail.

<sup>1531</sup> “For heatless desiccant dryers, the reduction in purge tends to be proportional only to the reduction of flow, not the reduction in moisture load due to the lower inlet temperatures.” The 50% value is based on the TRM’s assumption of a 50% dryer load factor used Illinois TRM Measure 4.7.5. Marshall, Ron. Lessons Learned: Saving Energy Costs with Heated Blower Desiccant Dryers. <https://www.airbestpractices.com/system-assessments/air-treatment2/lessons-learned-saving-energy-costs-heated-blower-desiccant-dry-0>

<sup>1532</sup> “But for heated style units, the dryer reacts to both reductions. This means some energy is saved due to flow reduction, and additional energy is saved due to the lower moisture load in the cooler inlet air, resulting in more energy savings when compared with heatless styles.” Marshall, Ron. Lessons Learned: Saving Energy Costs with Heated Blower Desiccant Dryers. <https://www.airbestpractices.com/system-assessments/air-treatment2/lessons-learned-saving-energy-costs-heated-blower-desiccant-dry-0>

Shift	Hours
Single Shift	1,976
Two Shifts	3,952
Three Shifts	5,928
Four Shifts or Continual Operation	8,320
Unknown / Weighted average <sup>1533</sup>	5,702

**SUMMER COINCIDENT PEAK DEMAND SAVINGS**

$$\Delta kW_{\text{peak}} = \Delta kWh / \text{HOU} * CF$$

Where:

CF = summer peak coincidence factor

Shift	Coincidence Factor
Single Shift	0.59
Two Shifts	0.95
Three Shifts	0.95
Four Shifts or Continual Operation	0.95
Unknown / Weighted average <sup>1534</sup>	0.89

**FOSSIL FUEL SAVINGS**

N/A

**WATER AND OTHER NON-ENERGY IMPACT DESCRIPTIONS AND CALCULATION**

N/A

**DEEMED O&M COST ADJUSTMENT CALCULATION**

N/A

**MEASURE CODE CI-CPA-DDRY-V03-240101**

**REVIEW DEADLINE: 1/1/2028**

<sup>1533</sup> Weighting of 16% single shift, 23% two shift, 25% three shift and 36% continual based on DOE evaluation of the Compressed Air Challenge, section 2.1.5 Facility Operating Schedules.

<sup>1534</sup> Weighting of 16% single shift, 23% two shift, 25% three shift and 36% continual based on DOE evaluation of the Compressed Air Challenge, section 2.1.5 Facility Operating Schedules.

## 4.7.8 Desiccant Dryer Dew Point Demand Controls

### DESCRIPTION

Compressed air is dried to reduce or eliminate condensation that can harm the compressed air system or end use equipment. For applications that require air to be dried below a dew point of 35°F,<sup>1535</sup> regenerative desiccant air dryers are typically used. Typically, regenerative desiccant dryers achieve pressure dew points as low as -40°F.

Regenerative desiccant dryers generally consist of two towers (or vertical tanks) filled with porous desiccant media. “Wet” compressed air flows through one tower, exiting as dried compressed air, while the other tower is dried out (or regenerated). This dryer alternates this process between towers to prevent compressed air flowing through saturated towers and damaging downstream equipment. The means of regeneration distinguishes the different types of regenerative dryer.

The energy use of these dryers is primarily due to regeneration of the desiccant. Standard dryers come equipped with a fixed, timer regeneration control. However, the actual load on the dryer is variable. Dew point demand controls (DPDC) adjust the amount of regeneration to the load on the dryer, reducing unnecessary purge energy. DPDC can be retrofit on existing desiccant dryers or integrated in new desiccant dryers.

Heatless Desiccant Dryer: Uses compressed air (“purge air”) to dry out the regenerating tower. The amount of purge air is typically between 15-20% of the dryer’s rate flow (CFM), regardless of the flow rate that the compressor is supplying.<sup>1536</sup> This type of dryer alternates tower regeneration approximately every 5 minutes.<sup>1537</sup>

Heated Desiccant Dryer: Uses a combination of compressed purge air and heat for regeneration. The amount of purge air is typically 5-10% of the dryer’s rate flow (CFM), regardless of the flow rate that the compressor is supplying.<sup>1538</sup> This type of dryer alternates tower regeneration approximately every 8 hours.<sup>1539</sup>

Externally Heated Blower Purge Dryer: Uses an external blower and heat source for regeneration. This type of dryer requires a small amount (2%) of purge air or ambient air to cool the tower after heating. This type of dryer alternates tower regeneration approximately every 8 hours.<sup>1540</sup> There is also a type of blower purge dryer called a zero purge dryer that eliminates all compressed purge air.

This measure was developed to be applicable to the following program types: RF

### DEFINITION OF EFFICIENT EQUIPMENT

The efficient equipment is a heatless, externally-heated, or blower purge regenerative desiccant dryer with dew point demand controls. The controls should be able to respond to changes in flow and moisture loading. Dryers installed on inlet modulation compressors do not qualify for this measure.

### DEFINITION OF BASELINE EQUIPMENT

The baseline equipment is a heatless, externally-heated, or blower purge regenerative desiccant dryer without dew point demand controls.

<sup>1535</sup> The dew point limitation of the most common refrigerant-type air dryer. Improving Compressed Air System Performance: A Sourcebook for Industry, US Department of Energy. Page 48.

<sup>1536</sup> Lessons Learned: Saving Energy Costs with Heated Blower Purge Desiccant Dryers, Marshall, Ron.

<sup>1537</sup> Regenerative Desiccant Compressed Air Dryers. White, Donald.

<sup>1538</sup> Types of Compressed Air Dryers 2: Refrigerant and Regenerative Desiccant, Compressed Air and Gas Institute (CAGI).

<sup>1539</sup> Regenerative Desiccant Compressed Air Dryers. White, Donald.

<sup>1540</sup> Regenerative Desiccant Compressed Air Dryers. White, Donald.

**DEEMED LIFETIME OF EFFICIENT EQUIPMENT**

The lifetime of this measure is 5 years.<sup>1541</sup>

**DEEMED MEASURE COST**

The estimated cost of the controls retrofit is \$4,000.<sup>1542</sup>

**LOADSHAPE**

Loadshape C35 – Industrial Process

**COINCIDENCE FACTOR**

The summer peak coincidence factor for this measure is dependent on the industrial shift and corresponding hours of operation. Values are provided for each shift type in the variable definition section.

---

**Algorithm**

---

**CALCULATION OF ENERGY SAVINGS**

**ELECTRIC ENERGY SAVINGS**

$$\Delta kWh = CFM_{Dryer} * (PF * kW_{Comp} + kW_{Heater} + kW_{Blower}) * HOU * PRF$$

Where:

CFM<sub>Dryer</sub> = rated capacity of the dryer in cubic feet per minute (CFM)

PF = purge flow of desiccant dryer (%)<sup>1543</sup>

Air Compressor Type	Purge Flow
Heatless	15%
Externally-Heated	7.5%
Blower Purge	2.0%

kW<sub>Comp</sub> = system power reduction per reduced air demand (kW/CFM) depending on the type of compressor control.<sup>1544</sup> If unknown, assume Screw – Load/Unload.

Air Compressor Type	ΔkW/CFM
Reciprocating – On/off Control	0.18
Reciprocating – Load/Unload	0.14
Screw – Load/Unload	0.15
Screw – Variable Displacement	0.15
Screw - VFD	0.18

Note: Dryers installed on inlet modulation compressors do not qualify for this measure.

---

<sup>1541</sup> Since this is a retrofit, the EUL is one-third of the dryer life which is 15 years (TRM 4.7.7). Focus on Energy Evaluation Business Programs: Measure Life Study, p. 91-92. PA Consulting Group. August 25, 2009.

<sup>1542</sup> Desiccant Air Dryer Control: Seeing Isn't Always Believing. Marshall, Ron.

<sup>1543</sup> Lessons Learned: Saving Energy Costs with Heated Blower Purge Desiccant Dryers, Marshall, Ron.

<sup>1544</sup> Consistent with Air Nozzle measure, this assumes the compressor will be between 40% and 100% capacity before and after the changes to the system demand. See "Industrial System Standard Deemed Saving Analysis.xls".

$kW_{\text{Heater}}$  = average power of heater per CFM of dryer (kW/CFM)<sup>1545, 1546</sup>  
 = 0.007 kW/CFM for heated models  
 = 0.013 kW/CFM for blower purge models

$kW_{\text{Blower}}$  = average power of blower per CFM of dryer (kW/CFM)<sup>1547</sup>  
 = 0.000 kW/CFM for heated models  
 = 0.003 kW/CFM for blower purge models

HOU = compressor total hours of operation below depending on shift

Shift	Hours
Single Shift	1,976
Two Shifts	3,952
Three Shifts	5,928
Four Shifts or Continual Operation	8,320
Unknown / Weighted average <sup>1548</sup>	5,702

PRF = purge reduction factor  
 = Assume 50% for heatless desiccant dryers<sup>1549</sup>  
 = Assume 60% for externally-heated or heated blower purge desiccant dryers<sup>1550</sup>

**SUMMER COINCIDENT PEAK DEMAND SAVINGS**

$$\Delta kW_{\text{peak}} = \Delta kWh / \text{HOU} * CF$$

Where:

CF = summer peak coincidence factor

<sup>1545</sup> Based on a review of data sheets from six manufacturers. These values reflect average heater kW and not nominal heater kW. The heater operation will vary based on moisture load to the dryer. See “IL TRM Desiccant Dryers – Supporting Information.xls” file for more detail.

<sup>1546</sup> The heater operation will be controlled by temperature to avoid overheating the desiccant media. Lessons Learned: Saving Energy Costs with Heated Blower Purge Desiccant Dryers, Marshall, Ron.

<sup>1547</sup> Based on a review of data sheets from six manufacturers. These values reflect average blower kW and not nominal blower kW. The blower operation will in many cases vary based on moisture load to the dryer. See “IL TRM Desiccant Dryers – Supporting Information.xls” file for more detail.

<sup>1548</sup> Weighting of 16% single shift, 23% two shift, 25% three shift and 36% continual based on DOE evaluation of the Compressed Air Challenge, section 2.1.5 Facility Operating Schedules.

<sup>1549</sup> “For heatless desiccant dryers, the reduction in purge tends to be proportional only to the reduction of flow, not the reduction in moisture load due to the lower inlet temperatures.” The 50% value is based on the TRM’s assumption of a 50% dryer load factor used Illinois TRM Measure 4.7.5. Marshall, Ron. Lessons Learned: Saving Energy Costs with Heated Blower Desiccant Dryers.

<sup>1550</sup> “But for heated style units, the dryer reacts to both reductions. This means some energy is saved due to flow reduction, and additional energy is saved due to the lower moisture load in the cooler inlet air, resulting in more energy savings when compared with heatless styles.” Marshall, Ron. Lessons Learned: Saving Energy Costs with Heated Blower Desiccant Dryers.

Shift	Coincidence Factor
Single Shift	0.59
Two Shifts	0.95
Three Shifts	0.95
Four Shifts or Continual Operation	0.95
Unknown / Weighted average <sup>1551</sup>	0.89

**FOSSIL FUEL SAVINGS**

N/A

**WATER AND OTHER NON-ENERGY IMPACT DESCRIPTIONS AND CALCULATION**

N/A

**DEEMED O&M COST ADJUSTMENT CALCULATION**

N/A

**MEASURE CODE CI-CPA-DPDC-V02-230101**

**REVIEW DEADLINE: 1/1/2027**

---

<sup>1551</sup> Weighting of 16% single shift, 23% two shift, 25% three shift and 36% continual based on DOE evaluation of the Compressed Air Challenge, section 2.1.5 Facility Operating Schedules.



## 4.7.9 Compressed Air Heat Recovery

### DESCRIPTION

Air compressors are inherently inefficient, converting 80 to 93% of the electrical input energy into heat.<sup>1552</sup> Recovering this wasted heat for useful purposes is one method for reducing facility-level energy use. Typical air compressor heat recovery involves ducting air-cooled air compressor exhaust for space heat. Recovered heat can also be used for process heating, water heating, and boiler makeup water heating, but this workpaper only addresses the most common scenario.

This measure was developed to be applicable to the following program types: RF, NC. If applied to other program types, the measure savings should be verified.

### DEFINITION OF EFFICIENT EQUIPMENT

The efficient equipment is an air-cooled air compressor that is ducted for heat recovery during the heating season. The ducting must include a thermostat that controls the heat recovery based on whether heating is needed.

### DEFINITION OF BASELINE EQUIPMENT

The baseline equipment is an air-cooled air compressor whose exhaust is ducted to the outdoors or to a space where heat is not needed (e.g., compressor room, unoccupied space).

### DEEMED LIFETIME OF EFFICIENT EQUIPMENT

15 years<sup>1553</sup>

### DEEMED MEASURE COST

\$80/hp<sup>1554</sup>

### LOADSHAPE

N/A

### COINCIDENCE FACTOR

N/A

---

### Algorithm

---

### CALCULATION OF ENERGY SAVINGS

#### ELECTRIC ENERGY SAVINGS

N/A

#### SUMMER COINCIDENT PEAK DEMAND SAVINGS

N/A

---

<sup>1552</sup> Ron Marshall, William Scales, Gary Shafer, Paul Shaw, Paul Sheaffer, Rick Stasyshan, H.P. Improving Compressed Air System Performance: A Sourcebook for Industry v3. United States: N. p., 2016.

<sup>1553</sup> The 15-year measure life is based on the value for HVAC controls within the ComEd EUL research. The ductwork has an estimated 20-year measure life but is limited by the mechanical and thermostatic controls.

<sup>1554</sup> This estimate is based on three representative projects received through the Nicor Custom Program. The costs in these three projects were \$73/hp, \$76/hp, and \$84/hp.

**FOSSIL FUEL SAVINGS**

$$\Delta\text{therms} = \eta_{\text{HR}} * 2,545 * \text{hp} * \text{PP} * \text{Hours} * \text{CHF} / 100,000 / \eta_{\text{heat}}$$

Where:

$\eta_{\text{HR}}$  = Efficiency of heat recovery

= 80%<sup>1555</sup>

2,545 = Conversion factor, Btu/hp-hr

hp = Nominal horsepower of the compressor

PP = Percent power at average load (% flow or capacity) conditions. See table below.

If average flow is unknown, assume 65%.<sup>1556</sup>

If compressor type is unknown, assume Load/No-load (1 gal/CFM).

= 93.5%

Avg. % Capacity	On/Off Control	Load/No-Load (1 gal/cfm)	Load/No-Load (10 gal/cfm)	Inlet Valve Modulation (w/o Blowdown)	Inlet Valve Modulation (w/ Blowdown)	Variable Displacement	VSD w/ Unloading	VSD w/ Stopping
0%	0%	27%	27%	71%	26%	25%	12%	0%
10%	10%	32%	35%	74%	40%	34%	20%	12%
20%	20%	63%	42%	76%	54%	44%	28%	24%
30%	30%	74%	52%	79%	62%	52%	36%	33%
40%	40%	81%	60%	82%	82%	61%	45%	41%
50%	50%	87%	68%	86%	86%	63%	53%	53%
60%	60%	92%	76%	88%	88%	69%	60%	60%
<b>65%</b>	<b>65%</b>	<b>94%</b>	<b>80%</b>	<b>90%</b>	<b>90%</b>	<b>73%</b>	<b>66%</b>	<b>66%</b>
70%	70%	95%	83%	92%	92%	77%	71%	71%
80%	80%	98%	89%	94%	94%	85%	80%	80%
90%	90%	100%	96%	97%	97%	91%	89%	89%
100%	100%	100%	100%	100%	100%	100%	100%	100%

Hours = Compressor hours of operation below depending on shift.

= Use actual hours if known, otherwise assume values in table below:

<sup>1555</sup> Ron Marshall, William Scales, Gary Shafer, Paul Shaw, Paul Sheaffer, Rick Stasyshan, H.P. Improving Compressed Air System Performance: A Sourcebook for Industry v3. United States: N. p., 2016 (page 14).

<sup>1556</sup> The analysis of compressor load factors for the Illinois TRM’s 4.7.1 VSD Air Compressor measure show an average load factor range of 63 – 65%. For more information, please see: “IL TRM VSD Air Compressor – Supporting Information.xls”.

Shift	Hours
Single Shift	1,976
Two Shifts	3,952
Three Shifts	5,928
Four Shifts or Continual Operation	8,320
Unknown / Weighted average <sup>1557</sup>	5,702

CHF = Climate heating factor. This value represents the amount of time that the facility has a use for space heating. See table below for values.<sup>1558</sup>

Zone	Climate Heating Factor
1 - Rockford	58%
2 - Chicago	55%
3 - Springfield	48%
4 - Belleville	49%
5 - Marion	46%

100,000 = Conversion factor, Btu/therm

$\eta_{\text{heat}}$  = Heating system efficiency

= If actual heating system efficiency is unknown, assume 80%<sup>1559</sup>

**WATER AND OTHER NON-ENERGY IMPACT DESCRIPTIONS AND CALCULATION**

N/A

**DEEMED O&M COST ADJUSTMENT CALCULATION**

N/A

**MEASURE CODE CI-CPA-CHR-V02-230101**

**REVIEW DEADLINE: 1/1/2027**

<sup>1557</sup> Weighting of 16% single shift, 23% two shift, 25% three shift and 36% continual based on DOE evaluation of the Compressed Air Challenge, section 2.1.5 Facility Operating Schedules.

<sup>1558</sup> These values reflect a ratio of the hours below a heating balance point over 8,760. The heating balance point is assumed to be 55°F. The data source is TMY3 data. See “Compressed Air Heat Recovery – Supporting Info” file for derivation.

<sup>1559</sup> 80% is the federal minimum efficiency of gas-fired unit heaters. Unit heaters are a common heat source in industrial and manufacturing settings, where compressed air is likely to be in place.

## 4.7.10 Compressed Air Storage Receiver Tank

### DESCRIPTION

Using an air receiver or storage tank will buffer the air demands of the system on the compressor, thus eliminating short cycling. Although a load/no-load compressor unloads in response to lowered demand, it does so over a period of time to prevent lubrication oil from foaming. Therefore, reducing the number of cycles reduces the number of transition times from load to no-load and saves energy.

To qualify for this measure an existing load/no-load compressor with a 1 gal/cfm storage ratio or a modulating w/ blowdown compressor must be replaced with a load/no-load compressor with an improved storage capacity and ratio.

This measure was developed to be applicable to the following program types: RF, NC. If applied to other program types, the measure savings should be verified.

### DEFINITION OF EFFICIENT EQUIPMENT

The efficient equipment is an oil-flooded load/no-load compressor with an improved storage capacity and ratio compared to the existing system. The cfm should reflect the rated capacity (in cfm) of all active compressors. If that value cannot be determined, compressor power can be converted to capacity using the rule-of-thumb of 4.5 cfm/hp.<sup>1560</sup>

### DEFINITION OF BASELINE EQUIPMENT

The baseline equipment is an oil-flooded load/no-load compressor with a 1 gal/cfm storage ratio or a modulating w/ blowdown compressor.

### DEEMED LIFETIME OF EFFICIENT EQUIPMENT

10 years

### DEEMED MEASURE COST

Incremental cost (\$) =  $4.67 * (\text{Tank}_E - \text{Tank}_B)^{1561}$

Where:

4.67 = air receiver tank size, in gallons, to equipment cost conversion factor

Tank<sub>E</sub> = efficient tank size (gallons)

Tank<sub>B</sub> = baseline tank size (gallons)

### LOADSHAPE

Loadshape C35 – Industrial Process

### COINCIDENCE FACTOR

The summer peak coincidence factor for this measure is dependent on the industrial shift and corresponding hours of operation. Values are provided for each shift type in the variable definition section.

---

<sup>1560</sup> The 4.5 cfm/hp rule of thumb is based on a rotary screw compressor delivering 4 to 5 cfm per 1 hp, "Relationship Between Pressure and Flow", Compressed Air System Best Practices, Industrial Utility Efficiency.

<sup>1561</sup> 2018 Vermont PUC: Technical Reference User Manual (TRM) Measure Savings Algorithms and Cost Assumptions

**Algorithm**

**CALCULATION OF ENERGY SAVINGS**

**ELECTRIC ENERGY SAVINGS**

$$\Delta kWh = 0.9 \times hp_{\text{compressor}} \times \text{Hours} \times (CF_b - CF_e)$$

Where:

- $\Delta kWh$  = gross customer annual kWh savings for the measure
- $hp_{\text{compressor}}$  = compressor motor nominal hp
- $0.9^{1562}$  = compressor motor nominal hp to full load kW conversion factor
- Hours = compressor total hours of operation below depending on shift

Shift	Hours	Description
Single shift (8/5)	1,976	7 AM – 3 PM, weekdays, minus some holidays and scheduled down time
2-shift (16/5)	3,952	7AM – 11 PM, weekdays, minus some holidays and scheduled down time
3-shift (24/5)	5,928	24 hours per day, weekdays, minus some holidays and scheduled down time
4-shift (24/7)	8,320	24 hours per day, 7 days a week minus some holidays and scheduled down time
Unknown / Weighted average <sup>1563</sup>	5,702	

- $CF_b$  = baseline compressor factor<sup>1564</sup>  
= See table below for baseline compressor factor. If compressor type is unknown, default to a load/no-load compressor with 1 gallon/cfm for the appropriate-sized compressor.

Baseline Compressor	Compressor Factor ( $\leq 40$ hp) <sup>1565</sup>	Compressor Factor (50 – 200 hp) <sup>1566</sup>
Modulating w/ blowdown	0.890	0.863
Load/No-Load w/ 1 gallon/cfm	0.909	0.887
Load/No-Load w/ 3 gallon/cfm	0.831	0.811
Load/No-Load w/ 4 gallon/cfm	0.812	0.792
Load/No-Load w/ 5 gallon/cfm	0.806	0.786

<sup>1562</sup> Conversion factor based on Survey of CAGI data sheets from 200 compressors. See “IL TRM VSD Air Compressor – Supporting Information.xls” for more information.

<sup>1563</sup> Weighting of 16% single shift, 23% two shift, 25% three shift and 36% continual based on DOE evaluation of the Compressed Air Challenge, section 2.1.5 Facility Operating Schedules.

<sup>1564</sup> Compressor factors were developed using DOE part load data for different compressor control types as well as load profiles from 50 facilities employing air compressors less than or equal to 40 hp, as sourced from the Efficiency Vermont TRM.

<sup>1565</sup> Compressor factors were developed using DOE part load data for different compressor control types as well as load profiles from 50 facilities employing air compressors less than or equal to 40 hp, as sourced from the Efficiency Vermont TRM. See “IL TRM VSD Air Compressor – Supporting Information.xls” for more information.

<sup>1566</sup> Compressor factors for this size range were developed using DOE part-load data for different compressor control types as well as load profiles from 45 compressors and 20 facilities. This data comes from ComEd Custom and Industrial Systems

CF<sub>e</sub> = efficient compressor factor  
 = See table above for load/no-load compressors with the adequate storage capacity installed. If unknown, default to load/no-load compressors w/ 4 gallons/cfm.

**For example**, a 1-shift facility with a 100-hp modulating (with blowdown) adds a 2,000-gallon receiver to their compressed air system. This improvement brings the system storage over 4 gallons/cfm.

*Capacity Check:* = 2,000 gallons / (100 hp \* 4.5 cfm/hp)  
 = 4.4 gallons/cfm

ΔkWh = 0.9 \* 100 \* 1,976 \* (0.863 – 0.792)  
 = 12,627 kWh

**SUMMER COINCIDENT PEAK DEMAND SAVINGS**

ΔkW = ΔkWh / Hours \* CF

Where:

CF = Summer peak coincidence factor for this measure

Shift	Coincidence Factor
1-shift (8/5)	0.59
2-shift (16/5)	0.95
3-shift (24/5)	0.95
4-shift (24/7)	0.95
Unknown / Weighted average <sup>1567</sup>	0.89

**For example**, a 1-shift facility with a 100-hp VSD modulating (with blowdown) compressor adds a 2,000-gallon receiver to their compressed air system. This improvement brings the system storage over 4 gallons per cfm.

*Capacity Check:* = 2,000 gallons / (100 hp \* 4.5 cfm/hp)  
 = 4.4 gallons per cfm

ΔkW = 12,627 / 1,976 \* 0.59  
 = 3.77 kW

**FOSSIL FUEL SAVINGS**

N/A

**WATER IMPACT DESCRIPTIONS AND CALCULATION**

N/A

---

programs. The compressors were filtered to reflect only rotary screw compressors, between 50 and 200 hp, and operating a minimum of 4 hour per day, Additionally, compressors with clear and consistent baseload profiles were excluded from this analysis. See "IL TRM VSD Air Compressor – Supporting Information.xls" for more information.

<sup>1567</sup> Weighting of 16% single shift, 23% two shift, 25% three shift and 36% continual based on DOE evaluation of the Compressed Air Challenge, section 2.1.5 Facility Operating Schedules.

**DEEMED O&M COST ADJUSTMENT CALCULATION**

N/A

**MEASURE CODE: CI-CPA-CASRT-V02-230101**

**REVIEW DEADLINE: 1/1/2027**

## 4.7.11 Reduce Compressed Air Setpoint

### DESCRIPTION

This measure characterizes the energy savings associated with reducing the compressed air pressure setpoint. A lower setpoint pressure results in the reduction of work requirements on the compressor resulting in energy savings. The energy savings assumptions are based on compressors operating at 100 psi.

This measure was developed to be applicable to the following program types: RF. If applied to other program types, the measure savings should be verified.

### DEFINITION OF EFFICIENT EQUIPMENT

The efficient equipment must meet the following requirements:

- Compressor setpoint must be decreased
- Specification and location of compressor must be known and verifiable

### DEFINITION OF BASELINE EQUIPMENT

The baseline equipment is an air compressor with a pressure setpoint higher than necessary (line pressure more than 115% of the highest end use requirement).

### DEEMED LIFETIME OF EFFICIENT EQUIPMENT

The expected measure life is 5 years.<sup>1568</sup>

### DEEMED MEASURE COST

The incremental cost is assumed to be \$0.

### LOADSHAPE

Loadshape C35 – Industrial Process

### COINCIDENCE FACTOR

The summer peak coincidence factor for this measure is dependent on the industrial shift and corresponding hours of operation. Values are provided for each shift type in the variable definition section.

---



---

### Algorithm

---

### CALCULATION OF ENERGY SAVINGS

#### ELECTRIC ENERGY SAVINGS

$$\Delta kWh = (kW_{\text{typical}} * \Delta P * SF * \text{Hours} / hp_{\text{typical}}) * hp_{\text{real}}$$

Where:

- $\Delta kWh$  = gross customer annual kWh savings for the measure
- $kW_{\text{typical}}$  = adjusted compressor power (kW) based on typical compressor loading and operating profile. Use actual compressor control type if known:

---

<sup>1568</sup> Based on value from ComEd Operational Efficiency CY2018 Impact Evaluation.



Control Type	kW <sub>typical</sub> <sup>1569</sup>
Reciprocating - On/off Control	70.2
Reciprocating - Load/Unload	74.8
Screw - Load/Unload	82.3
Screw - Inlet Modulation	82.5
Screw - Inlet Modulation w/ Unloading	82.5
Screw - Variable Displacement	73.2
Screw - VFD	70.8

= if the actual compressor control type is not known, use a weighted average based on the following market assumptions:

Control Type	Share %	kW <sub>typical</sub> <sup>1570</sup>
Market share estimation for load/unload control compressors	56%	74.8
Market share estimation for modulation w/unloading control compressors	27%	82.5
Market share estimation for variable displacement control compressors	17%	73.2
Weight average	-	76.6

$\Delta P$  = reduction in pressure differential between efficient and base case (psi)

= actual

SF = 1% reduction in power per 2 psi reduction in system pressure is equal to 0.5% reduction per 1 psi, or a Savings Factor of 0.005<sup>1571</sup>

HOURS = compressor total hours of operation below depending on shift

Shift	Hours	Description
Single shift (8/5)	1,976	7 AM – 3 PM, weekdays, minus some holidays and scheduled down time
2-shift (16/5)	3,952	7AM – 11 PM, weekdays, minus some holidays and scheduled down time
3-shift (24/5)	5,928	24 hours per day, weekdays, minus some holidays and scheduled down time
4-shift (24/7)	8,320	24 hours per day, 7 days a week minus some holidays and scheduled down time
Unknown / Weighted average <sup>1572</sup>	5,702	

hp<sub>typical</sub> = nominal hp for typical compressor

<sup>1569</sup> Consistent with 4.7.2 Compressed Air Low Pressure Drop Filters. See “Industrial System Standard Deemed Saving Analysis.xls”.

<sup>1570</sup> Based on Tables 8.2.2 and 8.2.3 from Technical Support Document: Air Compressors. US Department of Energy. May, 2016.

<sup>1571</sup> “Optimizing Pneumatic Systems for Extra Savings,” Compressed Air Best Practices, DOE Compressed Air Challenge, 2010.

<sup>1572</sup> Weighting of 16% single shift, 23% two shift, 25% three shift and 36% continual based on DOE evaluation of the Compressed Air Challenge, section 2.1.5 Facility Operating Schedules.

$$= 100 \text{ hp}^{1573}$$

$hp_{\text{real}}$  = total hp of real compressors distributing air through filter. This should include the total horsepower of the compressors that normally run through the filter, but not backup compressors.

**SUMMER COINCIDENT PEAK DEMAND SAVINGS**

$$\Delta kW = \Delta kWh / \text{Hours} * CF$$

Where:

CF = Summer peak coincidence factor for this measure

Shift	Coincidence Factor
Single shift (8/5)	0.59
2-shift (16/5)	0.95
3-shift (24/5)	0.95
4-shift (24/7)	0.95
Unknown / Weighted average <sup>1574</sup>	0.89

**FOSSIL FUEL SAVINGS**

N/A

**WATER IMPACT DESCRIPTIONS AND CALCULATION**

N/A

**DEEMED O&M COST ADJUSTMENT CALCULATION**

N/A

**MEASURE CODE: CI-CPA-RCAS-V02-230101**

**REVIEW DEADLINE: 1/1/2027**

---

<sup>1573</sup> Consistent with 4.7.2 Compressed Air Low Pressure Drop Filters. See “Industrial System Standard Deemed Saving Analysis.xls”.

<sup>1574</sup> Weighting of 16% single shift, 23% two shift, 25% three shift and 36% continual based on DOE evaluation of the Compressed Air Challenge, section 2.1.5 Facility Operating Schedules.

## 4.7.12 AODD Pump Controls

### DESCRIPTION

Diaphragm pumps are widely used for their numerous advantages, such as simplicity, serviceability, and durability. These pumps can tolerate fluids that are corrosive, viscous, or contain a significant portion of entrained solids (E.g., effluent and slurries). Diaphragm pumps can be driven by compressed air or electric motors. Air-operated double diaphragm (AODD) pumps are estimated to be present in up to 85-90% of manufacturing plants in the US.<sup>1575</sup> The intrinsic simplicity of AODDs allow them to have significantly lower upfront material costs than electric motor-driven diaphragm pumps since there is no electric motor.

Typically, AODDs are operated at a fixed capacity and do not have a controller attached. In this scenario, the pump consumes compressed air continuously when operating. An electronic stroke controller can reduce the amount of air that the AODD pump consumes while operating. This controller synchronizes the compressed air release with the pump so that the diaphragm experiences a burst of air rather than a continuous stream. This reduces the air consumption and noise generation of the pump. This technology increases the pressure variance experienced by the pump; however, the overall impact on fluid flow is negligible.<sup>1576</sup>

Typically, this technology is limited to larger AODD pump sizes ( $\geq 2''$ ), higher pressures ( $\geq 60$  psig) and applications with longer operation times. This technology might not be applicable for systems with highly viscous fluids.

This measure was developed to be applicable to the following program types: RF, TOS. If applied to other program types, the measure savings should be verified.

### DEFINITION OF EFFICIENT EQUIPMENT

The efficient equipment is an AODD pump with an electronic stroke optimizing control.

### DEFINITION OF BASELINE EQUIPMENT

The baseline equipment is an AODD pump operating at a fixed capacity.

### DEEMED LIFETIME OF EFFICIENT EQUIPMENT

10 years<sup>1577</sup>

### DEEMED MEASURE COST

Total cost is \$1,150. The material cost for this type of control is \$950.<sup>1578</sup> Labor is \$200, based on estimated time of 2 hours and \$100 per hour rate.<sup>1579</sup>

### LOADSHAPE

Loadshape C35 – Industrial Process

---

<sup>1575</sup> Hank Van Ormer. "Study Proves Potential Energy Savings of AODD Pump Controls," Compressed Air Best Practices. <https://www.airbestpractices.com/system-assessments/end-uses/study-proves-potential-energy-savings-aodd-pump-controls>

<sup>1576</sup> "Diaphragm Pump Controller Performance Project Report," Purdue School of Engineering and Technology. January 12, 2015.

<sup>1577</sup> This is an estimated based on lifetimes of similar electronic controls. HVAC controls generally have a 15-year EUL but are typically in less demanding environments than industrial pumping applications (e.g., manufacturing, wastewater treatment, etc.). For this reason, a more conservative value of 10 years was selected.

<sup>1578</sup> MizAir.com. Accessed August 4, 2020. <https://www.mizair.com/lp-miz>

<sup>1579</sup> Engineering judgement.

**COINCIDENCE FACTOR**

The summer peak coincidence factor for this measure is dependent on the industrial shift and corresponding hours of operation. Values are provided for each shift type in the variable definition section.

**Algorithm**

**CALCULATION OF ENERGY SAVINGS**

**ELECTRIC ENERGY SAVINGS**

$$\Delta kWh = CFM_{AODD} * kW_{Comp} * Hours * SF$$

Where:

$CFM_{AODD}$  = Rated flow of the AODD (CFM). Use actual, if known.

If unknown, see below for guidance.<sup>1580</sup>

Nominal Pump Size	Pressure Air Rang (psig)	Range of Air Consumption (SCFM)	Default Air Consumption (SCFM)
2"	80 – 120 psig (average = 95 psig)	90 – 120	105
3" & 4"	90 – 110 psig (average = 100 psig)	125 - 150	138

$kW_{Comp}$  = System power reduction per air demand (kW/CFM) depending on the type of air compressor found in table below.<sup>1581</sup> If unknown, assume Screw – Load/Unload.

Air Compressor Type	$kW_{Comp}$ (kW/CFM)
Reciprocating – On/off Control	0.18
Reciprocating – Load/Unload	0.14
Screw – Load/Unload	0.15
Screw – Variable Displacement	0.15
Screw – VFD	0.18

Hours = Compressed air system pressurized hours

= Use actual hours if known, otherwise assume values in table below:

Shift	Hours
Single Shift	1,976
Two Shifts	3,952
Three Shifts	5,928
Four Shifts or Continual Operation	8,320
Unknown / Weighted average <sup>1582</sup>	5,702

SF = Savings Factor, representing the reduction of compressed air consumed by the pump

<sup>1580</sup> "Demand-Side Savings: Energy Efficiency in Optimizing Compressed Air," Air Power USA. Page 8-46.

<sup>1581</sup> Calculated based on the type of compressor control. This assumes the compressor will be between 40% and 100% capacity before and after the changes to the system demand. See "Industrial System Standard Deemed Saving Analysis.xls"

<sup>1582</sup> Weighting of 16% single shift, 23% two shift, 25% three shift and 36% continual based on DOE evaluation of the Compressed Air Challenge, section 2.1.5 Facility Operating Schedules

$$= 35\%^{1583}$$

**For example**, a 2-inch AODD is outfitted with a stroke-optimizing control

$$\Delta kWh = 105 * 0.15 * 5,702 * 35\%$$

$$= 31,432 \text{ kWh}$$

**SUMMER COINCIDENT PEAK DEMAND SAVINGS**

$$\Delta kW = \Delta kWh / \text{Hours} * CF$$

Where:

$\Delta kWh$  = As calculated above

CF = Summer peak coincidence factor

Shift	Coincidence Factor
Single Shift	0.59
Two Shifts	0.95
Three Shifts	0.95
Four Shifts or Continual Operation	0.95
Unknown / Weighted average <sup>1584</sup>	0.89

**For example**, a 2-inch AODD is outfitted with a stroke-optimizing control

$$\Delta kW = 31,432 / 5,702 * 0.89$$

$$= 4.91 \text{ kW}$$

**FOSSIL FUEL SAVINGS**

N/A

**WATER AND OTHER NON-ENERGY IMPACT DESCRIPTIONS AND CALCULATION**

N/A

**DEEMED O&M COST ADJUSTMENT CALCULATION**

N/A

**MEASURE CODE: CI-CPA-AODD-V01-220101**

**REVIEW DEADLINE: 1/1/2025**

<sup>1583</sup> This is the average value of several references, the strongest of which is a lab study that reports a savings range of 20% - 50%. "Diaphragm Pump Controller Performance Project Report," Purdue School of Engineering and Technology. January 12, 2015. For a full list of savings estimates, see the "IL TRM AODD Controls – Supporting Info.xls"

<sup>1584</sup> Weighting of 16% single shift, 23% two shift, 25% three shift and 36% continual based on DOE evaluation of the Compressed Air Challenge, section 2.1.5 Facility Operating Schedules

## 4.7.13 Compressed Air Leak Repair

### DESCRIPTION

This measure shows the energy savings potential associated with reducing compressed air losses and the repair of compressed air leaks. Compressed air leaks can be responsible for 20-30% of total air compressor output in a facility. This measure is applicable to compressed air systems in manufacturing environments where blow off, pneumatic tools and manufacturing processes of many varieties are used.

This measure was developed to be applicable to the following program types: RF. If applied to other program types, the measure savings should be verified.

### DEFINITION OF EFFICIENT EQUIPMENT

The efficient condition is the compressed air system with air leaks identified via a leak survey and leak tags, and then leaks repaired to minimize compressed air wastage.

### DEFINITION OF BASELINE EQUIPMENT

The baseline condition is an existing compressed air system.

### DEEMED LIFETIME OF EFFICIENT EQUIPMENT

The expected measure life is 1 to 5 years.<sup>1585</sup> A range of possible lifetime values is provided as the implementer of this measure must justify the reason for selecting an appropriate measure life for each project and the decision will be subject to evaluation with the risk of adjustment.

### DEEMED MEASURE COST

The incremental cost is assumed to be \$8 per horsepower<sup>1586</sup>

### LOADSHAPE

Loadshape C35 - Industrial Process

### COINCIDENCE FACTOR

The summer peak coincidence factor for this measure is dependent on the industrial shift and corresponding hours of operation. Values are provided for each shift type in the variable definition section.

---



---

### Algorithm

---

### CALCULATION OF ENERGY SAVINGS

#### ELECTRIC ENERGY SAVINGS

$$\Delta kWh = (N_{leaks} * CFM_{leaks} * Hours * C_{aircomp} * Control\ factor / hp_{typical}) * hp_{real}$$

Where:

$N_{leaks}$  = Number of leaks repaired

---

<sup>1585</sup> For more detail pertaining to the guidance of the measure life, please see Attachment B: Effective Useful Life for Custom Measure Guidelines

<sup>1586</sup> Engineering estimate from previous project cost data review and engineering judgment as obtained from Minnesota Technical Reference Manual Version 1.2, Industrial Compressed Air – Compressed Air Leak Detection

$CFM_{leaks}$  = CFM loss per leak from table below<sup>1587</sup>

Pressure (psig)	Leak Orifice Diameter (inches)					
	1/64	1/32	1/16	1/8	1/4	3/8
<b>70</b>	0.3	1.2	4.8	19.2	76.7	173
<b>80</b>	0.33	1.3	5.4	21.4	85.7	193
<b>90</b>	0.37	1.5	5.9	23.8	94.8	213
<b>100</b>	0.41	1.6	6.5	26	104	234
<b>125</b>	0.49	2	7.9	31.6	126	284

\*Values in CFM

$C_{aircomp}$  = Compressor efficiency

= Actual, if unknown compressor type, use 0.19 kW/CFM<sup>1588</sup>

Type	$C_{aircomp}$ kW/CFM
Single-acting Reciprocating Air Compressor	0.23
Double-acting Reciprocating Air Compressor	0.155
Lubricant-injected Rotary Screw Compressor	0.185
Lubricant-free Rotary Screw Compressor	0.2
Centrifugal Compressor	0.18
<b>Average/unknown</b>	<b>0.19</b>

Hours = Compressor hours of operation below depending on shift:

Shift	Hours	Description
Single shift (8/5)	1,976	7 AM – 3 PM, weekdays, minus three-weekday holidays and 10 days of scheduled down time
2-shift (16/5)	3,952	7AM – 11 PM, weekdays, minus three-weekday holidays and 10 days of scheduled down time
3-shift (24/5)	5,928	24 hours per day, weekdays, minus three-weekday holidays and 10 days of scheduled down time
4-shift (24/7)	8,320	24 hours per day, 7 days a week minus three-week day holidays and 10 days of scheduled down time
Unknown / Weighted average	5,702	

Control factor = Efficiency Factors per control type for air compressors from table below. If unknown control type, use 0.3 %kW/%load<sup>1589</sup>

Control Type	Control factor %kW/%load
Inlet Valve Modulated	0.31
Variable Displacement	0.69
Variable Speed Drive	0.85

<sup>1587</sup> Leakage rates(cfm) for different supply pressures and approximately equivalent orifice sizes obtained from Energy Tips – Minimize Compressed Air Leaks [Minimize Compressed Air Leaks; Industrial Technologies Program \(ITP\) Compressed Air Tip Sheet #3 \(Fact Sheet\) \(energy.gov\)](#)

<sup>1588</sup> Compressed Air Challenge "Fundamentals of Compressed Air Systems" Pg 28-32

<sup>1589</sup> Compressed Air Challenge "Fundamentals of Compressed Air Systems" Pg 90-91

hp<sub>typical</sub> = nominal horsepower of a typical air compressor  
 = 100 hp<sup>1590</sup>

hp<sub>real</sub> = total hp of real compressors. This should include the total horsepower of the compressors that normally run through the filter, but not backup compressors  
 = Actual

**SUMMER COINCIDENT PEAK DEMAND SAVINGS**

$$\Delta kW = (\Delta kWh / \text{Hours}) * CF$$

Where,

CF = Summer peak coincidence factor, see table below

Shift	Coincidence Factor
Single shift (8/5)	0.59
2-shift (16/5)	0.95
3-shift (24/5)	0.95
4-shift (24/7)	0.95
<b>Unknown / Weighted average<sup>1591</sup></b>	<b>0.89</b>

**NATURAL GAS SAVINGS**

N/A

**WATER AND OTHER NON-ENERGY IMPACT DESCRIPTIONS AND CALCULATION**

N/A

**DEEMED O&M COST ADJUSTMENT CALCULATION**

N/A

**MEASURE CODE: CI-CPA-CALR-V01-240101**

**REVIEW DEADLINE: 1/1/2029**

---

<sup>1590</sup> Consistent with 4.7.2 Compressed Air Low Pressure Drop Filters. See “Industrial System Standard Deemed Saving Analysis.xls”.

<sup>1591</sup> Weighting of 16% single shift, 23% two shift, 25% three shift and 36% continual based on DOE evaluation of the Compressed Air Challenge, section 2.1.5 Facility Operating Schedules.



## 4.8. Miscellaneous End Use

### 4.8.1 Pump Optimization

#### DESCRIPTION

Pump improvements can be done to optimize the design and control of centrifugal water pumping systems, including water solutions with freeze protection up to 15% concentration by volume. Other fluid and gas pumps cannot use this measure calculation. The measurement of energy and demand savings for commercial and industrial applications will vary with the type of pumping technology, operating hours, efficiency, and existing and proposed controls. Depending on the specific application slowing the pump, trimming or replacing the impeller may be suitable options for improving pumping efficiency. Pumps up to 40 HP are allowed to use this energy savings calculation. Larger motors should use a custom calculation (which may result in larger savings than this measure would claim).

#### DEFINITION OF EFFICIENT EQUIPMENT

In order for this characterization to apply, the efficient equipment is proven to be an optimized centrifugal pumping system meeting the applicable program efficiency requirements:

Pump balancing valves no more than 15% throttled

Balancing valves on at least one load 100% open.

#### DEFINITION OF BASELINE EQUIPMENT

In order for this characterization to apply, the baseline equipment is assumed to be the existing pumping system including existing controls and sequence of operations.

#### DEEMED LIFETIME OF EFFICIENT EQUIPMENT

The expected measure life is assumed to be 8 years.<sup>1592</sup>

#### DEEMED MEASURE COST

The incremental capital cost for this measure can vary considerably depending upon the strategy employed to achieve the required efficiency levels and should be determined on a site-specific basis.

#### LOADSHAPE

Loadshape C14: Indust. 1-shift (8/5) (e.g., comp. air, lights)

Loadshape C15: Indust. 2-shift (16/5) (e.g., comp. air, lights)

Loadshape C16: Indust. 3-shift (24/5) (e.g., comp. air, lights)

Loadshape C17: Indust. 4-shift (24/7) (e.g., comp. air, lights)

#### COINCIDENCE FACTOR

The summer peak coincidence factor for this measure is assumed to be 38%.<sup>1593</sup>

---

<sup>1592</sup> SCE Pump Test Final Report (2009), Summit Blue Consulting, LLC. This value is a weighted average of estimates provided by program participants.

<sup>1593</sup> Summer Peak Coincidence Factor has been preserved from the "Technical Reference Manual" (TRM) for Ohio Senate Bill 221 Energy Efficiency and Conservation Program and 09-512-GE-UNC," October 15, 2009. This is likely a conservative estimate, but is recommended for further study (as stated in the OH State TRM, page 269).

**Algorithm**

**CALCULATION OF SAVINGS**

**ELECTRIC ENERGY SAVINGS**

$$\Delta kWh = (HP_{motor} * 0.746 * LF / \eta_{motor}) * HOURS * ESF$$

Where:

HP<sub>motor</sub> = Installed nameplate motor horsepower  
 = Actual

0.746 = Conversion factor from horse-power to kW (kW/hp)

LF / η<sub>motor</sub> = Combined as a single factor since efficiency is a function of load  
 = 0.65<sup>1594</sup>

Where:

LF = Load Factor; Ratio of the peak running load to the nameplate rating of the motor

η<sub>motor</sub> = Motor efficiency at pump operating conditions

HOURS = Annual operating hours of the pump  
 = Actual

ESF = Energy Savings Factor; assume a value of 15%.<sup>1595</sup>

**SUMMER COINCIDENT PEAK DEMAND SAVINGS**

$$\Delta kW = (HP_{motor} * 0.746 * (LF / \eta_{motor})) * (ESF) * CF$$

Where:

CF = Summer Coincident Peak Factor for measure

**FOSSIL FUEL SAVINGS**

N/A

**WATER IMPACT DESCRIPTIONS AND CALCULATION**

N/A

**DEEMED O&M COST ADJUSTMENT CALCULATION**

N/A

**MEASURE CODE: CI-MSC-PMPO-V04-220101**

**REVIEW DEADLINE: 1/1/2027**

<sup>1594</sup> “Measured Loading of Energy Efficient Motors - the Missing Link in Engineering Estimates of Savings,” ACEEE 1994 Summer Study Conference, Asilomar, CA.

<sup>1595</sup> Published estimates of typical pumping efficiency improvements range from 5 to 40%. For analysis purposes, assume 15%. United States Industrial Electric Motor Systems Market Opportunities Assessment December 2002, Table E-7, Page 18.

## 4.8.2 Roof Insulation for C&I Facilities

### DESCRIPTION

Energy and demand saving are realized through reductions in the building cooling and heating loads by way of improvements in roof assembly thermal resistance properties. This measure was developed to be applicable to the following program types: RF and NC.

If applied to other program types, the measure savings should be verified.

### DEFINITION OF EFFICIENT EQUIPMENT

The efficient condition is a roof assembly with thermal resistance that exceeds code requirements and should be determined by the program.

### DEFINITION OF BASELINE EQUIPMENT

The baseline condition in retrofit scenarios is the thermal resistance of the existing roof assembly.

The baseline for new construction scenarios is the thermal resistance of the roof assembly as mandated by applicable building code. Assembly R-values shall be referenced from IECC 2015 or ASHRAE – 90.1 – 2013, or IECC 2018 or ASHRAE 90.1-2016, or IECC 2021, depending on the IECC in effect on the date of the building permit (if unknown assume IECC 2018).

Note, IECC 2021 is expected to become effective statewide in 2023. IECC 2018 is the requisite code for any projects with permitting dates spanning July 1, 2019 to the IECC 2021 effective date. Prior to July 1, 2019, IECC 2015 is the applicable code. As code requirements and adoption can differ from municipality to municipality, the user should verify which version of code is applicable given these constraints.

### DEEMED LIFETIME OF EFFICIENT EQUIPMENT

The measure expected useful life (EUL) is assumed to be 20 years per DEER 2008. This is consistent with SDG&E’s 9th Year Measure Retrofit Study (1996 & 1997 Residential Weatherization Programs), CPUC’s Energy Efficiency Policy Manual v.2, and GDS’s Measure Life Report Residential and Commercial/Industrial Lighting and HVAC Measures (June 2007).

### DEEMED MEASURE COST

Costs can be highly variable due to differences in building type and structural assemblies and for that reason actual costs should be used when possible. Absent of actual cost information, estimated costs can be used. Per the W017 Itron California Measure Cost Study,<sup>1596</sup> the material cost for R-30 insulation is \$0.59 per square foot. The installation cost is \$0.81 per square foot. The total measure cost, therefore, is \$1.40 per square foot of insulation installed.

### LOADSHAPE

Loadshape C03: Commercial Cooling

### COINCIDENCE FACTOR

$CF_{SSP}$  = Summer System Peak Coincidence Factor for Commercial cooling (during system peak hour)  
 = 91.3%<sup>1597</sup>

$CF_{PJM}$  = PJM Summer Peak Coincidence Factor for Commercial cooling (average during peak period)

---

<sup>1596</sup> Measure costs are from the “2010-2012 W0017 Ex Ante Measure Cost Study”, Itron, California Public Utilities Commission, May 2014. The data is provided in a file named “MCS Results Matrix – Volume I”.

<sup>1597</sup> Based on analysis of Itron eShape data for Missouri, calibrated to Illinois loads, supplied by Ameren. The AC load during the utility’s peak hour is divided by the maximum AC load during the year.

= 47.8%<sup>1598</sup>

---



---

**Algorithm**

---



---

**CALCULATION OF ENERGY SAVINGS**

**ELECTRIC ENERGY SAVINGS**

Electric energy savings is calculated as the sum of energy saved when cooling the building and energy saved when heating the building

$$\Delta kWh = \Delta kWh_{cooling} + \Delta kWh_{heating}$$

If central cooling, the electric energy saved in annual cooling due to the added insulation is

$$\Delta kWh_{cooling} = ((1/R_{existing}) - (1/R_{new})) * Area * EFLH_{cooling} * \Delta T_{FL,cooling} / 1,000 / \eta_{cooling}$$

Where:

R<sub>existing</sub> = Roof assembly heat loss coefficient with existing (or code required) insulation [(hr-°F-ft<sup>2</sup>)/Btu]

= In retrofit scenarios, actual existing conditions prior to retrofit should be used. If unavailable, default values by building type can be used, as outlined in the following table and adopted from Ohio Energy Technical Reference Manual and expanded to cover all type of commercial buildings in the state of Illinois. In new construction scenarios, the applicable code requirements, per the following tables, should be used.

For retrofits, the R-value for the entire assembly:

Building Type	Retrofit Assembly R-Value
Assembly	13.5
Assisted Living	13.5
College	13.5
Convenience Store	13.5
Elementary School	13.5
Garage	13.5
Grocery	13.5
Healthcare Clinic	13.5
High School	13.5
Hospital	13.5
Hotel/Motel	13.5
Manufacturing Facility	12.0
MF - High Rise	13.5
MF - Mid Rise	13.5
Movie Theater	13.5
Office - High Rise	13.5
Office - Low Rise	13.5
Office - Mid Rise	13.5
Religious Building	13.5
Restaurant	13.5

<sup>1598</sup> Based on analysis of Itron eShape data for Missouri, calibrated to Illinois loads, supplied by Ameren. The average AC load over the PJM peak period (1-5pm, M-F, June through August) is divided by the maximum AC load during the year.

Building Type	Retrofit Assembly R-Value
Retail - Department Store	13.5
Retail - Strip Mall	13.5
Warehouse	12.0
Unknown	13.5

R-Values: ASHRAE – 90.1 – 2013 and 2016

	IL TRM Zones 1, 2, & 3 [ASHRAE/IECC Climate Zone 5 (A, B, C)]			
	Nonresidential		Semiheated	
	Assembly Maximum	Insulation Min. R-Value	Assembly Maximum	Insulation Min. R-Value
Insulation Entirely Above Deck	0.032	R-30.0 c.i.	0.063	R-15 c.i.
Metal Building (Roof)	0.037	R-19 + R-11 Ls or R-25 + R-8 Ls	0.082	R-19
Attic and Other	0.021	R-49	0.034	R-30

	IL TRM Zones 4 & 5 [ASHRAE/IECC Climate Zone 4 (A, B, C)]			
	Nonresidential		Semiheated	
	Assembly Maximum	Insulation Min. R-Value	Assembly Maximum	Insulation Min. R-Value
Insulation Entirely Above Deck	0.032	R-30.0 c.i.	0.093	R-10 c.i.
Metal Building (Roof)	0.037	R-19 + R-11 Ls or R-25 + R-8 Ls	0.082	R-19
Attic and Other	0.021	R-49	0.034	R-30

**Table Notes**  
c.i. = continuous insulation

Ls = linear system, a continuous vapor barrier liner installed below the purlins and uninterrupted by framing members

$R_{new}$  = Roof assembly heat loss coefficient with new insulation [(hr-°F-ft²)/Btu]

Area = Area of the roof surface in square feet.

$EFLH_{cooling}$  = Equivalent Full Load Hours for Cooling [hr] in Existing Buildings or New Construction are provided in Section 4.4, HVAC end use

$\Delta T_{FL,cooling}$  = Temperature difference [°F] during cooling season between design day outdoor air temperature ( $T_{DD}$ ) and assumed 55°F base temperature

Climate Zone (City based upon)	$T_{DD,cooling}$ [°F] <sup>1599</sup>	$\Delta T_{FL,cooling}$ [°F]
1 (Rockford)	90.9	35.9
2 (Chicago)	91.3	36.3
3 (Springfield)	92.6	37.6
4 (Belleville)	95.2	40.2

<sup>1599</sup> Weather Station Data, 0.4% Cooling DB - 2021 ASHRAE Handbook, Fundamentals. The following weather stations were referenced: Climate Zone 1: Chicago Rockford Int'l, Climate Zone 2: Chicago O'Hare Int'l, Climate Zone 3: Abraham Lincoln Capital, Climate Zone 4: Scott AFB, Climate Zone 5: Cape Girardeau Regional.

Climate Zone (City based upon)	T <sub>DD,cooling</sub> [°F] <sup>1599</sup>	ΔT <sub>FL,cooling</sub> [°F]
5 (Marion)	94.4	39.4

- 1,000 = Conversion from Btu to kBtu
- η<sub>cooling</sub> = Efficiency of cooling system. Actual, if known. Alternatively, use IECC 2012 as a default source if equipment type is known, or as deemed assume SEER 13<sup>1600</sup>

If the building is heated with electric heat (resistance or heat pump), the electric energy saved in annual heating due to the added insulation is

$$\Delta kWh_{heating} = [(1/R_{existing}) - (1/R_{new})] * Area * EFLH_{heating} * \Delta T_{FL,heating} / 3,412 / \eta_{heating}$$

Where:

- EFLH<sub>heating</sub> = Equivalent Full Load Hours for Heating [hr] in Existing Buildings or New Construction are provided in Section 4.4, HVAC end use
- ΔT<sub>FL,heating</sub> = Temperature difference [°F] during heating season between design day outdoor air temperature and assumed 55°F heating base temperature

Climate Zone (City based upon)	T <sub>DD,heating</sub> [°F] <sup>1601</sup>	ΔT <sub>FL,heating</sub> [°F]
1 (Rockford)	-5.4	60.4
2 (Chicago)	-1.0	56.0
3 (Springfield)	1.1	53.9
4 (Belleville)	7.2	47.8
5 (Marion)	10.1	44.9

- 3,142 = Conversion from Btu to kWh.
- η<sub>heating</sub> = Efficiency of heating system. Use actual efficiency. If not available refer to default table below.

System Type	Age of Equipment	HSPF Estimate	η <sub>Heat</sub> (Effective COP Estimate) (HSPF/3.413)*0.85
Heat Pump	Before 2006	6.8	1.7
	After 2006	7.7	1.92
Resistance	N/A	N/A	1

If the building is heated with a gas furnace, there will be some electric savings in heating the building attributed to extra insulation since the furnace fans will run less.

$$\Delta kWh_{heating} = \Delta Therms * Fe * 29.3$$

Where:

- ΔTherms = Gas savings calculated with equation below.

<sup>1600</sup> Simplified version of IECC 2012 as a conservative estimate of what is existing.

<sup>1601</sup> Weather Station Data, 96.6% Heating DB - 2021 ASHRAE Handbook, Fundamentals. The following weather stations were referenced: Climate Zone 1: Chicago Rockford Int'l, Climate Zone 2: Chicago O'Hare Int'l, Climate Zone 3: Abraham Lincoln Capital, Climate Zone 4: Scott AFB, Climate Zone 5: Cape Girardeau Regional.

- Fe = Percentage of heating energy consumed by fans, assume 7.7%<sup>1602</sup>
- 29.3 = Conversion from therms to kWh

**SUMMER COINCIDENT PEAK DEMAND SAVINGS**

$$\Delta kW = (\Delta kWh_{cooling} / EFLH_{cooling}) * CF$$

Where:

- EFLH<sub>cooling</sub> = Equivalent full load hours of air conditioning in Existing Buildings or New Construction are provided in Section 4.4, HVAC end use
- CF<sub>SSP</sub> = Summer System Peak Coincidence Factor for Commercial cooling (during system peak hour)  
= 91.3% <sup>1603</sup>
- CF<sub>PJM</sub> = PJM Summer Peak Coincidence Factor for Commercial cooling (average during peak period)  
= 47.8% <sup>1604</sup>

**FOSSIL FUEL SAVINGS**

If building uses a gas furnace, the savings resulting from the insulation is calculated with the following formula.

$$\Delta Therms = ((1/R_{existing}) - (1/R_{new})) * Area * EFLH_{heating} * \Delta T_{FL,heating} / 100,000 / \eta_{heat}$$

Where:

- R<sub>existing</sub> = Roof assembly heat loss coefficient with existing (or code required) insulation [(hr-°F-ft<sup>2</sup>)/Btu], per guidance outlined in Electric Energy Savings section.
- R<sub>new</sub> = Roof assembly heat loss coefficient with new insulation [(hr-°F-ft<sup>2</sup>)/Btu]
- Area = Area of the roof surface in square feet. Assume 1000 sq ft for planning.
- EFLH<sub>heating</sub> = Equivalent Full Load Hours for Heating in Existing Buildings or New Construction are provided in Section 4.4, HVAC end use
- ΔT<sub>FL,heating</sub> = Temperature difference [°F] between design day outdoor air temperature and during heating season (see above)
- 100,000 = Conversion from BTUs to Therms
- η<sub>heat</sub> = Efficiency of existing furnace. Assume 0.78 for planning purposes.

**WATER IMPACT DESCRIPTIONS AND CALCULATION**

N/A

**DEEMED O&M COST ADJUSTMENT CALCULATION**

N/A

<sup>1602</sup> F<sub>e</sub> is estimated using TRM models for the three most popular building types for programmable thermostats: low-rise office (10.2%), sit-down restaurant (8.6%), and retail – strip mall (4.4%). 7.7% reflects the average F<sub>e</sub> of the three building types. See “Fan Energy Factor Example Calculation 2021-06-23.xlsx” for reference.

<sup>1603</sup> Based on analysis of Itron eShape data for Missouri, calibrated to Illinois loads, supplied by Ameren. The AC load during the utility’s peak hour is divided by the maximum AC load during the year.

<sup>1604</sup> Based on analysis of Itron eShape data for Missouri, calibrated to Illinois loads, supplied by Ameren. The average AC load over the PJM peak period (1-5pm, M-F, June through August) is divided by the maximum AC load during the year.

**MEASURE CODE: CI-MSC-RINS-V08-240101**

**REVIEW DEADLINE: 1/1/2029**



### 4.8.3 Computer Power Management Software

#### DESCRIPTION

This measure characterizes the savings achieved through controlling the power management settings of a desktop computer, monitor or laptop. This can be achieved one of two ways; either a centralized computer power management software is installed on a network of computers to monitor and record usage and manage the power management settings of all units (referred to as Centralized Software), or the settings are adjusted on each individual unit (referred to as Individual Settings).

#### DEFINITION OF EFFICIENT EQUIPMENT

For Centralized Software, the efficient equipment is defined by the requirements listed below:

- Allow centralized control and override of computer power management settings of workstations which include both a computer monitor and CPU (i.e., a desktop or laptop computer on a distributed network)
- Be able to control on/off/sleep states on both the CPU and monitor according to the Network Administrator-defined schedules and apply power management policies to network groups
- Have capability to allow networked workstations to be remotely wakened from power-saving mode (e.g. for system maintenance or power/setting adjustments)
- Have capability to detect and monitor power management performance and generate energy savings reports
- Have capability to produce system reports to confirm the inventory and performance of equipment on which the software is installed.

For Individual Settings, each desktop, monitor, or laptop requires power settings to be adjusted to appropriately place devices in a low-power standby, sleep or off mode after a predetermined period of inactivity (for example display sleep mode after 10 minutes of inactivity and computer sleep mode after 30 minutes).

This measure was developed to be applicable to the following program types: RF. If applied to other program types, the measure savings should be verified.

#### DEFINITION OF BASELINE EQUIPMENT

Baseline is defined as a desktop computer, monitor or laptop without the power management settings enabled.

#### DEEMED LIFETIME OF EFFICIENT EQUIPMENT

For Centralized Software, the expected measure life is five years.<sup>1605</sup>

For Individual Settings, the expected measure life is two years.<sup>1606</sup>

#### DEEMED MEASURE COST

For Centralized Software, the deemed measure cost is \$29 per networked computer, including labor.<sup>1607</sup>

For Individual Settings, the deemed measure cost is \$10 per unit.<sup>1608</sup>

---

<sup>1605</sup> Computers and peripheral equipment are considered 5-year property. 2016 IRS Publication 946.

<https://www.irs.gov/pub/irs-prior/p946--2016.pdf>

<sup>1606</sup> Reduced estimate accounting for settings only lasting as long as units are in operation and the ease at which they can be turned off or adjusted in any one individual machine, due to personal preference.

<sup>1607</sup> Work Paper WPSCNROE0003 Revision 1, Power Management Software for Networked Computers. Southern California Edison.

<sup>1608</sup> Estimate assuming 15 minutes of labor at \$40/hour rate.

**LOADSHAPE**

Loadshape C21: Commercial Office Equipment.

**COINCIDENCE FACTOR**

N/A

---



---

**Algorithm**

---



---

**CALCULATION OF ENERGY SAVINGS**

**ELECTRIC ENERGY SAVINGS**

$$\Delta kWh = ((UECCompBase - UECCompEff) + (UECMonBase - UECMonEff))$$

Where:

UECComBase = Energy consumption of computer before adjusting power settings  
 $(\sum State PowerState \times HoursBase,State) / 1,000$

UECComEff = Energy consumption of computer after adjusting power settings  
 $(\sum State PowerState \times HoursEff,State) / 1,000$

UECMonBase = Energy consumption of monitor before adjusting power settings  
 $(\sum State MpW \times PowerState \times HoursBase,State) / 1,000$

UECMonEff = Energy consumption of monitor after adjusting power settings  
 $(\sum State MpW \times PowerState \times HoursEff,State) / 1,000$

HoursBase,State = Annual hours in each power state<sup>1609</sup>  
 $8,760 \times BaseDutyCycle(\%)$

Computer Power State	Base Duty Cycle	
	Computer	Monitor
Unplugged	5%	22%
Off	55%	50%
Sleep	2%	2%
Idle	35%	N/A
Active	3%	26%

Hours Eff,State = Annual hours in each power state<sup>1610</sup>  
 $8,760 \times EfficientDutyCycle(\%)$

<sup>1609</sup> Northwest Regional Technical Forum Non-Res Network Computer Power Management , January 29, 2015. Analysis can be found in NonResNetCompPwrMgt\_v4\_1.xlsm. <https://rtf.nwcouncil.org/measure/non-res-network-computer-power-management>

<sup>1610</sup> Northwest Regional Technical Forum Non-Res Network Computer Power Management , January 29, 2015. Analysis can be found in NonResNetCompPwrMgt\_v4\_1.xlsm. <https://rtf.nwcouncil.org/measure/non-res-network-computer-power-management>

Computer Power State	Efficient Duty Cycle	
	Computer	Monitor
Unplugged	5%	22%
Off	77%	57%
Sleep	2%	2%
Idle	13%	N/A
Active	3%	19%

PowerState = Power (W) consumption in each power state<sup>1611</sup>

Computer Power State	Power Draw (Watts)		
	Desktop Computer	Laptop Computer	Monitor
Unplugged	0.0	0.0	0.0
Off	0.9	0.5	0.23
Sleep	2.1	0.9	0.32
Idle	39.9	8.9	N/A
Active	72.2	60.0	14.43

**For example: Computer Savings:**

$$\text{kWh savings} = (\text{UECCompBase} - \text{UECCompEff})$$

$$\text{UECCompBase} = 0 \times 5\% \times 8,760 + 0.9 \times 55\% \times 8,760 + 2.1 \times 2\% \times 8,760 + 39.9 \times 35\% \times 8,760 + 72.2 \times 3\% \times 8,760 = 146.2 \text{ kWh}$$

$$\text{UECCompEff} = 0 \times 5\% \times 8760 + 0.9 \times 77\% \times 8760 + 2.1 \times 2\% \times 8760 + 39.9 \times 13\% \times 8760 + 72.2 \times 3\% \times 8760 = 70.5 \text{ kWh}$$

$$\text{Computer kWh savings} = (146.2 - 70.5) = 75.7 \text{ kWh}$$

**For example: Laptop Savings:**

$$\text{UECCompBase} = 0 \times 5\% \times 8,760 + 0.5 \times 55\% \times 8,760 + 0.9 \times 2\% \times 8,760 + 8.9 \times 35\% \times 8,760 + 60.0 \times 3\% \times 8,760 = 45.6 \text{ kWh}$$

$$\text{UECCompEff} = 0 \times 5\% \times 8760 + 0.5 \times 77\% \times 8760 + 0.9 \times 2\% \times 8760 + 8.9 \times 13\% \times 8760 + 60.0 \times 3\% \times 8760 = 29.4 \text{ kWh}$$

$$\text{Laptop kWh savings} = (45.6 - 29.4) = 16.2 \text{ kWh}$$

**For example: Monitor Savings (assuming CPMS is controlling 2 monitors):**

$$\text{Monitor kWh savings} = (\text{UECMonBase} - \text{UECMonEff})$$

$$\text{UECMonBase} = (2 \times 0 \times 22\% \times 8,760 + 2 \times 0.23 \times 50\% \times 8,760 + 2 \times 0.32 \times 2\% \times 8,760 + 2 \times 14.43 \times 26\% \times 8,760) / 1,000 = 67.9 \text{ kWh}$$

$$\text{UECMonEff} = (2 \times 0 \times 22\% \times 8760 + 2 \times 0.23 \times 57\% \times 8,760 + 2 \times 0.32 \times 2\% \times 8,760 + 2 \times 14.43 \times 19\% \times 8,760) / 1,000 = 50.5 \text{ kWh}$$

$$\text{Monitor kWh savings} = (67.9 - 50.5) = 17.4 \text{ kWh}$$

**SUMMER COINCIDENT PEAK DEMAND SAVINGS**

$$\Delta \text{kW} = \Delta \text{kWh} / 8760$$

<sup>1611</sup> Northwest Regional Technical Forum Non-Res Network Computer Power Management , January 29, 2015. Analysis can be found in NonResNetCompPwrMgt\_v4\_1.xlsm. <https://rtf.nwcouncil.org/measure/non-res-network-computer-power-management>

Computer peak kW savings	= 75.7/8760	= 0.009 kW
Laptop peak kW savings	= 16.2/8760	= 0.002 kW
Monitor (assuming CPMS is controlling 2 monitors) peak kW savings	=17.4/8760	= 0.002 kW

**NATURAL GAS SAVING**

NA

**WATER IMPACT DESCRIPTIONS AND CALCULATION**

NA

**DEEMED O&M COST ADJUSTMENT CALCULATION**

For Centralized Software, assume \$2/unit <sup>1612</sup>

For Individual Settings, no O&M impacts.

**MEASURE CODE: CI-MSC-CPMS-V04-220101**

**REVIEW DEADLINE: 1/1/2025**

---

<sup>1612</sup> Based on Dimetrosky, S., Luedtke, J. S., & Seiden, K. (2005). Surveyor Network Energy Manager: Market Progress Evaluation Report, No. 2 (Northwest Energy Efficiency Alliance report #E05-136). Portland, OR: Quantec LLC and review of CLEARResult document providing Qualifying Software Providers for ComEd program and their licensing fees; "Qualifying Vendor Software Comparison.pdf".

#### 4.8.4 Modulating Commercial Gas Clothes Dryer

**DESCRIPTION**

This measure relates to the installation of a two-stage modulating gas valve retrofit kit on a standard commercial non-modulating gas dryer. Commercial gas clothes dryers found in coin-operated laundromats or on-premise laundromats (hospitals, hotels, health clubs, etc.) traditionally have a single firing rate which is sized properly for highest heat required in initial drying stages but is oversized for later drying stages requiring lesser heat. This causes the burner to cycle on/off frequently, resulting in less efficient drying and wasted gas. Replacing the single stage gas valve with a two-stage gas valve allows the firing rate to adjust to the changing heat demand, thereby reducing overall gas consumption.

This measure was developed to be applicable to the following program types: RF.

If applied to other program types, the measure savings should be verified.

**DEFINITION OF EFFICIENT EQUIPMENT**

A 30 to 250 pound capacity commercial gas dryer retrofitted with a two-stage modulating gas valve kit.

**DEFINITION OF BASELINE EQUIPMENT**

A 30 to 250 pound capacity commercial gas dryer with no modulating capabilities.

**DEEMED LIFETIME OF EFFICIENT EQUIPMENT**

The deemed measure life for the retrofit kit is 10 years.<sup>1613</sup>

**DEEMED MEASURE COST**

The full retrofit cost is assumed to be \$700, including the material cost for the basic modulating gas valve retrofit kit (\$600) and the associated of labor for installation (\$100).<sup>1614</sup>

**LOADSHAPE**

N/A

**COINCIDENCE FACTOR**

N/A

---

**Algorithm**

---

**CALCULATION OF SAVINGS**

**ELECTRIC ENERGY SAVINGS**

N/A

**SUMMER COINCIDENT PEAK DEMAND SAVINGS**

N/A

---

<sup>1613</sup> Since this is a retrofit measure to an existing piece of equipment the measure life is less than the full life of the drier. Assumed to be 10 years as cost would be prohibitive for older machines that are likely to be need replacing soon.

<sup>1614</sup> Engineering judgement, based on observed costs during Nicor Gas pilot study. "Nicor Gas Emerging Technology Program, 1036: Commercial Dryer Modulation Retrofit Public Project Report." 2014.

**FOSSIL FUEL SAVINGS**

*Note: Accurately estimating dryer energy consumption is complicated and challenging due to a variety of factors that influence cycle times and characteristics and ultimately drying energy requirements. Clothing loads can vary by weight, volume, fiber composition, physical structure, and initial water content, meaning that for any given cycle drying energy requirements can differ. Additionally, dryer settings selected by the user as well as interactions with the site’s HVAC systems are known to influence dryer performance. As better information becomes available, this characterization can be modified to allow for a more site-specific estimation of savings.*

$$\Delta\text{Therms} = N_{\text{Cycles}} * SF$$

Where:

$N_{\text{Cycles}}$  = Number of dryer cycles per year. Refer to the table below if this value is not directly available.

Application	Cycles per Year
Coin- Operated Laundromats <sup>1615</sup>	1,483
Multi-family Dryers <sup>1616</sup>	1,074
On-Premise Laundromats <sup>1617</sup>	3,607

SF = Savings factor  
 = 0.18 therms/cycle<sup>1618</sup>

If using default cycles the savings are as follows:

Application	$\Delta\text{Therms}$
Coin- Operated Laundromats <sup>1619</sup>	267
Multi-family Dryers <sup>1620</sup>	193
On-Premise Laundromats <sup>1621</sup>	649

**WATER IMPACT DESCRIPTIONS AND CALCULATION**

N/A

**DEEMED O&M COST ADJUSTMENT CALCULATION**

N/A

**MEASURE CODE: CI-MSC-MODD-V02-230101**

**REVIEW DEADLINE: 1/1/2027**

<sup>1615</sup> From DOE’s Federal Register Notices, Energy Conservation Program: Energy Conservation Standards for Commercial Clothes Dryers, Office of Energy Efficiency & Renewable Energy.

<sup>1616</sup> Ibid.

<sup>1617</sup> Average value for dryer cycles in healthcare facility, hotels, drycleaners and laundromats from tests conducted in Nicor Gas Emerging Technology Program’s Commercial Dryer Modulation Retrofit Public Project Report.

<sup>1618</sup> Based on Illinois weather data, and average dryer performance for laundromat (30 to 45lb) and hotel (75 to 170 lb) dryers. See GTI Analysis.xlsx for complete derivation.

<sup>1619</sup> From DOE’s Federal Register Notices, Energy Conservation Program: Energy Conservation Standards for Commercial Clothes Dryers, Office of Energy Efficiency & Renewable Energy.

<sup>1620</sup> Ibid.

<sup>1621</sup> Average value for dryer cycles in healthcare facility, hotels, drycleaners and laundromats from tests conducted in Nicor Gas Emerging Technology Program’s Commercial Dryer Modulation Retrofit Public Project Report.

## 4.8.5 High Speed Clothes Washer

### DESCRIPTION

This measure applies to the installation of clothes washers with extraction speeds of 200G or greater, which is significantly higher than traditional hard-mount washers. Standard washer extractors in laundromats operate at speeds of 70-80G<sup>1622</sup>. The high-speed extraction process in the wash cycle removes more water from each compared to standard washers, reducing operating time and gas consumption of clothes dryers. Heat exposure and mechanical action are also reduced, resulting in less linen wear.

This measure was developed to be applicable to the following program types: TOS, NC, EREP. If applied to other program types, the measure savings should be verified.

### DEFINITION OF EFFICIENT EQUIPMENT

The efficient equipment is assumed to be a clothes washer with an extraction speed of 200G or greater, installed in a commercial laundromat. This measure is only applicable for sites utilizing gas dryers. Sites using electric dryers are not eligible for participation.

### DEFINITION OF BASELINE EQUIPMENT

The baseline equipment is assumed to be a clothes washer with an extraction speed of 100G or less, installed in a commercial laundromat.

### DEEMED LIFETIME OF EFFICIENT EQUIPMENT

The measure lifetime is assumed to be the typical lifetime of a commercial clothes washer: 7 years.<sup>1623</sup>

For early replacement measures it is assumed the existing unit would last another 2.3 years.<sup>1624</sup>

### DEEMED MEASURE COST<sup>1625</sup>

The incremental cost for time of sale is \$11.83/lb capacity.

The full cost of the high speed washer for early replacement applications is \$201.10/lb capacity. The deferred replacement cost of the baseline unit is \$189.27/lb capacity. This future cost should be discounted to present value using the real discount rate.

### LOADSHAPE

N/A

### COINCIDENCE FACTOR

N/A

---

<sup>1622</sup> “The Real Size of a Front Load Washer”, Laundromat123

<sup>1623</sup> “Assessment of Water Savings for Commercial Washers: Report on the Monitoring and Assessment of Water Savings from the Coin-Operated Multi-Load Clothes Washers Voucher Initiative Program.” San Diego County Water Authority October 2016.

<sup>1624</sup> One-third of expected measure life.

<sup>1625</sup> Measure costs are based on data from a 2016 quote provided by a commercial washer distributor to Franklin Energy Services, adjusted for inflation.

**Algorithm**

**CALCULATION OF SAVINGS**

**ELECTRIC ENERGY SAVINGS**

N/A

**SUMMER COINCIDENT PEAK DEMAND SAVINGS**

N/A

**FOSSIL FUEL SAVINGS**

$$\Delta\text{Therms} = (\text{Ncycles} * \text{Days} * \text{Capacity} * \text{RMC} * h_e / \eta_{\text{dryer}} / 100,000) * \text{DryerUse} * \text{LF}$$

Where:

Ncycles = Average number of washer cycles per day

= Use values from table below, depending on application

Application	Ncycles
Coin-operated Laundromats	4.3 <sup>1626</sup>
Multi-family	3.4 <sup>1627</sup>
Hotel/Motel/Hospital	10.4 <sup>1628</sup>

Days = Days per year of commercial laundromat operation

= Actual, or if unknown, assume 360 days<sup>1629</sup>

Capacity = Clothes washer rated capacity (lb/cycle)<sup>1630</sup>

= Actual

RMC = Retained Moisture Content (%)<sup>1631</sup> reduction from replacing a low extraction speed washer

= Assume 15%<sup>1632</sup>

<sup>1626</sup>“2014-2015 State of the Self-Service Laundry Industry Report.” Carlo Calma, April 13, 2015.

<sup>1627</sup> “Assessment of Water Savings for Commercial Washers: Report on the Monitoring and Assessment of Water Savings from the Coin-Operated Multi-Load Clothes Washers Voucher Initiative Program.” San Diego County Water Authority October 2016.

<sup>1628</sup> “Laundry Planning Guide.” EDRO, January 2015.

<sup>1629</sup> Based on professional judgement, assuming closed on holidays.

<sup>1630</sup> Clothes washer capacity is based on weight of dry clothing.

<sup>1631</sup> The EDRO “Laundry Planning Guide” describes moisture retention as “the ratio of retained moisture weight to clean dry textile weight.” The pounds of water retained by clothing at the end of a wash cycle is calculated by multiplying Capacity (lbs of dry clothing per cycle) by RMC.

<sup>1632</sup> Using chart provided (Figure 1) and assuming a 50/50 cloth blend load of cotton and polyester, the retained moisture drops from approximately 65% to 50% when a 100 g washer is replaced with a 200 g washer. Chart from “Laundry Planning Guide.” EDRO, January 2015. The Department of Energy test procedures for commercial clothes washers specifies, “...the use of energy test cloth consisting of a pure finished bleach cloth, made with a momie or granite weave, which is a blended fabric of 50-percent cotton and 50-percent polyester.” – Energy Conservation Program: Energy Conservation Standards for Commercial Clothes Washers; Final Rule, Notice of Proposed Rulemaking, DOE, March 2014 (10 CFR Part 431).



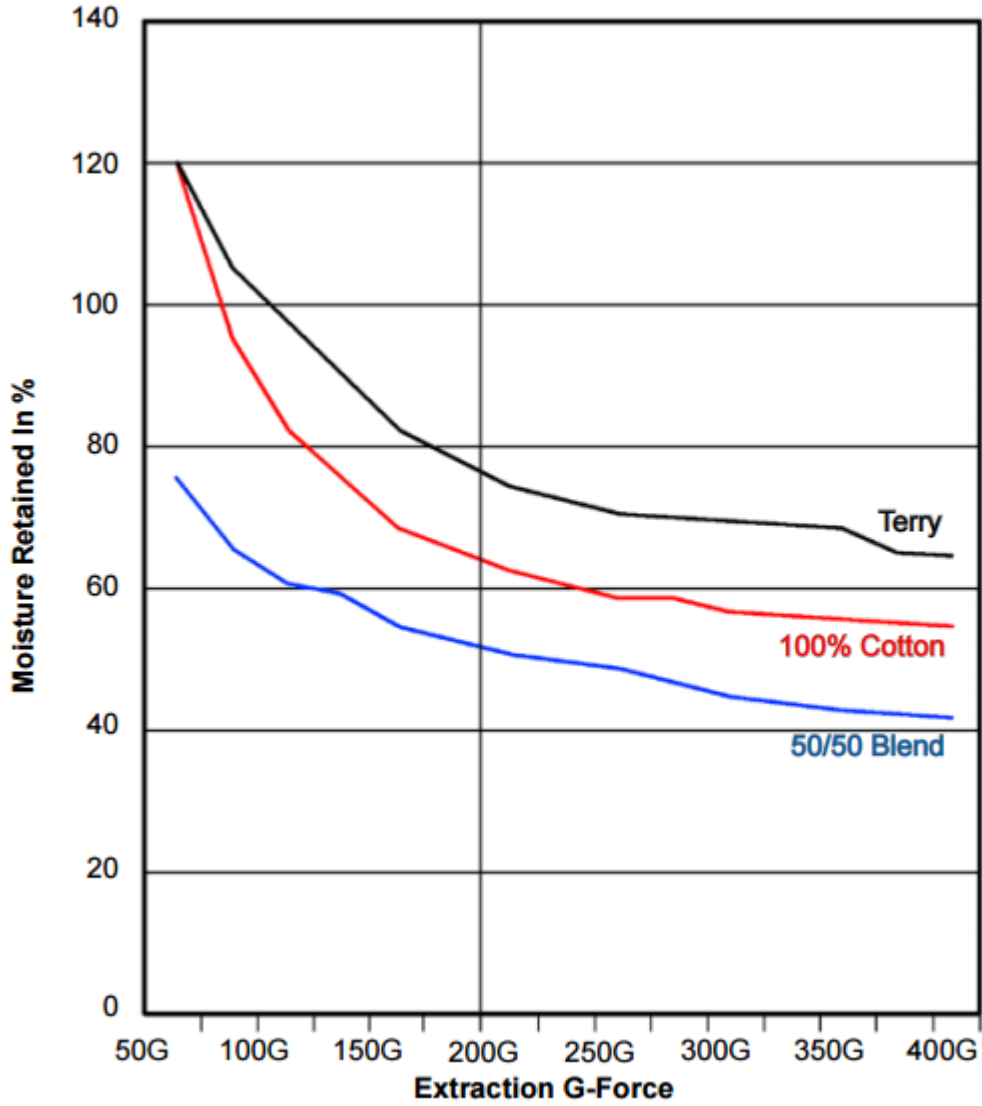

Figure 1

$h_e$  = Heat required by a dryer to evaporate 1 lb of water

= Assume 1,200 Btu/lb<sup>1633</sup>

$\eta_{dryer}$  = Efficiency of the clothes dryer

= Actual, or if unknown, assume 60%<sup>1634</sup>

100,000 = Converts Btus to therms

DryerUse = % of washer loads dried in the field

= Assume 91%<sup>1635</sup>

LF = Load Factor (%) to account for the pounds per washer load, as a percentage of rated capacity

<sup>1633</sup> "Laundry Planning Guide." EDRO, January 2015.

<sup>1634</sup> ACEEE (2010), "Are We Missing Energy Savings in Clothes Dryers?" Paul Bendt (Ecos), 2010

<sup>1635</sup> "Dryer Field Study." Northwest Energy Efficiency Alliance, November 20, 2014.

= Assume 66%<sup>1636</sup>

**For example**, a clothes washer with a 14 lb/cycle capacity and installed at a coin-operated laundromat, using default assumptions, would save:

$$\begin{aligned}\Delta\text{Therms} &= (\text{Ncycles} * \text{Days} * \text{Capacity} * \text{RMC} * h_e / \eta_{\text{dryer}} / 100,000) * \text{DryerUse} * \text{LF} \\ &= (4.3 * 360 * 14 * 0.25 * 1,200 / 0.60 / 100,000) * 0.91 * 0.66 \\ &= 65 \text{ therms}\end{aligned}$$

**WATER AND OTHER NON-ENERGY IMPACT DESCRIPTIONS AND CALCULATION**

N/A

**DEEMED O&M COST ADJUSTMENT CALCULATION**

N/A

**MEASURE CODE: CI-MSC-HSCW-V03-240101**

**REVIEW DEADLINE: 1/1/2027**

---

<sup>1636</sup>“Assessment of Water Savings for Commercial Washers: Report on the Monitoring and Assessment of Water Savings from the Coin-Operated Multi-Load Clothes Washers Voucher Initiative Program.” San Diego County Water Authority October 2016.

## 4.8.6 ENERGY STAR Computers

### DESCRIPTION

This measure estimates savings for a desktop computer with ENERGY STAR (ES) Version 8.0 rating, ES 8.0 +20%, ES 8.0 with 80 PLUS Platinum PSUs, and ES 8.0 with 80 PLUS Titanium PSUs.

This measure was developed to be applicable to the following program types: TOS. If applied to other program types, the measure savings should be verified.

### DEFINITION OF EFFICIENT EQUIPMENT

The efficient product is a desktop with a rating of ENERGY STAR Version 8.0 rating, ES 8.0 +20%, ES 8.0 with 80 PLUS Platinum PSUs, or ES 8.0 with 80 PLUS Titanium PSUs.

### DEFINITION OF BASELINE EQUIPMENT

Non ENERGY STAR qualified equipment with standard efficiency power supply.

### DEEMED LIFETIME OF EFFICIENT EQUIPMENT

The life of this measure is 4 years.<sup>1637</sup>

### DEEMED MEASURE COST<sup>1638</sup>

The incremental cost for an 80 Plus Desktop PSU is \$5.

The incremental cost for an ENERGY STAR desktop PSU is \$20.

### LOADSHAPE

C21 Commercial Office Equipment

### COINCIDENCE FACTOR

N/A

---



---

### Algorithm

---

### CALCULATION OF ENERGY SAVINGS

#### ELECTRIC ENERGY SAVINGS<sup>1639</sup>

$$\Delta \text{kWh} = 8760/1000 * (((\text{Watts}_{\text{Base,Off}} * \% \text{Time}_{\text{Off}}) + (\text{Watts}_{\text{Base,Sleep}} * \% \text{Time}_{\text{Sleep}}) + (\text{Watts}_{\text{Base,Long}} * \% \text{Time}_{\text{Long}}) + (\text{Watts}_{\text{Base,Short}} * \% \text{Time}_{\text{Short}})) - ((\text{Watts}_{\text{Eff,Off}} * \% \text{Time}_{\text{Off}}) + (\text{Watts}_{\text{Eff,Sleep}} * \% \text{Time}_{\text{Sleep}}) + (\text{Watts}_{\text{Eff,Long}} * \% \text{Time}_{\text{Long}}) + (\text{Watts}_{\text{Eff,Short}} * \% \text{Time}_{\text{Short}})))$$

Where (see assumptions in table below):

8760/1000 = Converts W to kWh

Watts<sub>Base,Off</sub> = baseline equipment power in off mode

%Time<sub>Off</sub> = typical percent of time a desktop, integrated desktop or notebook is in off mode during the year

<sup>1637</sup> Codes and Standards Enhancement (CASE) Initiative For PY 2013: Title 20 Standards Development. Analysis of Standards Proposal for Computers, August 6, 2013. Section 2.3 Design Life, Page 15.

<sup>1638</sup> NEEA Research Into Action, 80 PLUS Market Progress Evaluation Report #5, November 26, 2013. Page 24.

<sup>1639</sup> ENERGY STAR Program Requirements for Computers - Eligibility Criteria v8.0, Section 3.5.2.v., Equation 1: TEC Calculation (ETEC) for Desktop, Integrated Desktop, and Notebook Computers, pg 12.

- Watts<sub>Base,Sleep</sub> = baseline equipment power in sleep mode
- %Time<sub>Sleep</sub> = typical percent time in sleep mode
- Watts<sub>Base,Long</sub> = baseline equipment power in long idle mode
- %Time<sub>Long</sub> = typical percent time in long idle mode
- Watts<sub>Base,Short</sub> = baseline equipment power in short idle mode
- %Time<sub>Short</sub> = typical percent time in short idle mode
- Watts<sub>Eff,Off</sub> = efficient equipment power in off mode
- Watts<sub>Eff,Sleep</sub> = efficient equipment power in sleep mode
- Watts<sub>Eff,Long</sub> = efficient equipment power in long idle mode
- Watts<sub>Eff,Short</sub> = efficient equipment power in short idle mode

Measure Annual Mode Time (%)	Off	Sleep	Long Idle	Short Idle
Duty cycle – Commercial Desktop <sup>1640</sup>	15%	45%	10%	30%

Measure Watt Draw in Mode (Watts)	Off	Sleep	Long Idle	Short Idle
Baseline <sup>1641</sup>	0.88	2.1	26.5	27.9
ES 8.0 Desktops <sup>1642</sup>	0.64	1.54	14.97	19.62
ES 8.0 +20% Desktops <sup>1643</sup>	0.64	1.53	14.47	19.22
ES 8.0 Desktops w/ 80 PLUS Platinum PSUs <sup>1644</sup>	0.50	1.50	13.97	18.30
ES 8.0 Desktops w/ 80 PLUS Titanium PSUs <sup>1645</sup>	0.50	1.50	13.67	17.91

Calculated energy consumption in each mode, and savings provided below:

Measure TEC by Mode - Commercial	Off	Sleep	Long Idle	Short Idle	TEC (kWh/yr)	Savings (kWh/yr)
Baseline	1.2	8.3	23.2	73.3	106.0	N/A
ES 8.0 Desktops	0.8	6.1	13.1	51.6	71.6	34.4
ES 8.0 +20% Desktops	0.8	6.0	12.7	50.5	70.1	35.9

<sup>1640</sup> ENERGY STAR Program Requirements for Computers - Eligibility Criteria v8.0, Section 3.5.2.v., Table 4: Mode Weightings for Desktops and Integrated Desktop Computers, pg 13.

<sup>1641</sup> Codes and Standards Enhancement (CASE) Initiative For PY 2013: Title 20 Standards Development. Computers: Technical Report - Supplemental Analysis and Test Results, January 21, 2014.

<sup>1642</sup> Analysis of current DT I2 Category Desktops in the ENERGY STAR version 8.0 Qualified Products List (QPL) as accessed on 5/6/2020 (see File "ENERGY STAR\_Computers\_Analysis\_2020.xlsx", Sheet "DT I2 Stats").

<sup>1643</sup> Analysis of current DT I2 Category Desktops in the ENERGY STAR version 8.0 Qualified Products List (QPL), passing with > 20% margin, as accessed on 5/6/2020 (see File "ENERGY STAR\_Computers\_Analysis\_2020.xlsx", Sheet "DT I2 Stats").

<sup>1644</sup> 80 PLUS program savings calculator, additional 7% reduction in idle power levels over ENERGY STAR version 7.0 computers with 80 PLUS Silver PSU levels. The program calculator was used to establish relative and comparable savings, and as a result, absolute idle power values do not match. For more details on the derivation of the 6.7% savings factor, please see, "80 PLUS Desktop Savings\_25Aug2014\_Revised ESv8.xlsx", 'Analysis Summary' tab.

<sup>1645</sup> 80 PLUS program savings calculator, additional 9.1% reduction in idle power levels over ENERGY STAR version 7.0 computers with 80 PLUS Silver PSU levels. The program calculator was used to establish relative and comparable savings, and as a result, absolute idle power values do not match. For more details on the derivation of the 8.7% savings factor, please see, "80 PLUS Desktop Savings\_25Aug2014\_Revised ESv8.xlsx", 'Analysis Summary' tab.

Measure TEC by Mode - Commercial	Off	Sleep	Long Idle	Short Idle	TEC (kWh/yr)	Savings (kWh/yr)
ES 8.0 Desktops w/ 80 PLUS Platinum PSUs	0.7	5.9	12.2	48.1	66.9	39.1
ES 8.0 Desktops w/ 80 PLUS Titanium PSUs	0.7	5.9	12.0	47.1	65.6	40.3

Savings calculations can be referenced in “ENERGY STAR Computers Analysis\_2020\_Revised.xlsx”

**SUMMER COINCIDENT PEAK DEMAND SAVINGS<sup>1646</sup>**

$$\Delta kW = (Watts_{Base} - Watts_{Eff}) / 1000 * CF$$

Where:

Watts<sub>Base</sub> = Assumed average baseline wattage during peak period (see table below)

Watts<sub>Eff</sub> = Assumed average efficient wattage during peak period (see table below)

CF = Summer Peak Coincidence Factor

= 1.0

Calculated average demand during peak period, and savings provided below:

Measure Demand Reduction by Mode	TEC (Watts)	Long Idle Demand Savings (kW)	Short Idle Demand Savings (kW)	Weighted Average Demand Savings (kW)
Baseline	14.1	N/A	N/A	N/A
ES 8.0 Desktops	9.5	0.0115	0.0083	0.0091
ES 8.0 +20% Desktops	9.3	0.0120	0.0087	0.0095
ES 8.0 Desktops w/ 80 PLUS Platinum PSUs	8.9	0.0125	0.0096	0.0103
ES 8.0 Desktops w/ 80 PLUS Titanium PSUs	8.7	0.0128	0.0100	0.0107

Please note, the last column is a weighted average of the Long & Short Idle Modes and should be the value used in calculations. All Savings calculations can be referenced in “ENERGY STAR Computers Analysis\_2020\_Revised.xlsx”

**FOSSIL FUEL SAVINGS**

N/A

**WATER AND OTHER NON-ENERGY IMPACT DESCRIPTIONS AND CALCULATION**

N/A

**DEEMED O&M COST ADJUSTMENT CALCULATION**

N/A

<sup>1646</sup> It assumed that computers will not be off during peak period, and that the weighting of sleep, long idle and short idle during peak hours is consistent with the whole year. Wattage assumptions are weighted accordingly and coincidence factor is thus assumed to be 1.0 – see “ENERGY STAR Computers Analysis\_2020\_Revised.xlsx” for calculation.

**MEASURE CODE: CI-MSC-COMP-V03-210101**

**REVIEW DEADLINE: 1/1/2025**

## 4.8.7 Advanced Power Strip – Tier 1 Commercial

### DESCRIPTION

This measure relates to Advanced Power Strips – Tier 1 which are multi-plug power strips with the ability to automatically disconnect specific connected loads depending upon the power draw of a control load, also plugged into the strip. Power is disconnected from the switched (controlled) outlets when the control load power draw is reduced below a certain adjustable threshold, thus turning off the appliances plugged into the switched outlets. By disconnecting, the standby load of the controlled devices, the overall load of a centralized group of equipment (e.g. a desk workstation) can be reduced. In a commercial office space, savings generally occur during off-hours, when connected equipment continues to consume electricity while in standby mode or when off. Uncontrolled outlets are also provided that are not affected by the control device and so are always providing power to any device plugged into it.

This measure was developed to be applicable to the following program types: DI, Kits.

If applied to other program types, the measure savings should be verified.

### DEFINITION OF EFFICIENT EQUIPMENT

The efficient case is an advanced power strip with a load-sensing master plug and at least two controlled plugs.

### DEFINITION OF BASELINE EQUIPMENT

The assumed baseline is a standard power strip with surge protection that does not control connected loads.

### DEEMED LIFETIME OF EFFICIENT EQUIPMENT

The assumed lifetime of the advanced power strip is 7 years.<sup>1647</sup>

### DEEMED MEASURE COST

For direct install the actual full equipment and installation cost (including labor) and for kits the actual full equipment cost should be used.

Equipment cost if unknown<sup>1648</sup>:

Baseline Cost	Efficient Cost	Incremental Cost	Equipment
\$20	\$30	\$10	

### LOADSHAPE

Loadshape C47 – Standby Losses – Commercial Office<sup>1649</sup>

<sup>1647</sup> This is a consistent assumption with 5.2.2 Advanced Power Strip – Tier 2.

<sup>1648</sup> Price survey performed by Illume Advising LLC for IL TRM workpaper, see “Current Surge Protector Costs and Comparison 7-2016” spreadsheet.

<sup>1649</sup> Loadshapes were calculated from empirical studies and compared to the existing loadshape in Volume 1, Table 3.5. The studies were:

Acker, Brad *et al.*, “Office Space Plug Load Profiles and Energy Saving Interventions,” 2012 ACEEE Summer Study on Energy Efficiency in Buildings.

Sheppy, M. *et al.*, “Reducing Plug Loads in Office Spaces” Hawaii and Guam Energy Improvement Technology Demonstration Project, NREL/NAVFAC (January 2014).

**COINCIDENCE FACTOR**

N/A due to no savings attributable to standby losses between 1 and 5 PM.

---

**Algorithm**

---

**CALCULATION OF ENERGY SAVINGS**

**ELECTRIC ENERGY SAVINGS**

$$\Delta kWh^{1650} = ((kW_{wkday} * (hrs_{wkday} - hrs_{wkday-open})) + (kW_{wkend} * (hrs_{wkend} - hrs_{wkend-open}))) * weeks/year * ISR$$

Where:

- $kW_{wkday}$  = Standby power consumption of connected electronics on weekday off-hours. If unknown, assume 0.0315 kW.
- $kW_{wkend}$  = Standby power consumption of connected electronics on weekend off-hours. If unknown, assume 0.00617 kW.
- $hrs_{wkday}$  = total hours during the work week (Monday 7:30 AM to Friday 5:30 PM)  
= 106
- $hrs_{wkend}$  = total hours during the weekend (Friday 5:30 PM to Monday 7:30 AM)  
= 62
- $hrs_{wkday-open}$  = hours the office is open during the work week. If unknown, assume 50 hours.
- $hrs_{wkend-open}$  = hours the office is open during the weekend. If unknown, assume 0 hours.
- $weeks/year$  = number of weeks per year  
= 52.2
- $ISR$  = In Service Rate  
= Assume 0.969 for commercial Direct Install application<sup>1651</sup>, or 0.71 for kit distribution<sup>1652</sup>.

**For example**, an office open 9 hours per day (45 hours per week) on weekdays and 4 hours on Saturday:

$$\begin{aligned} \Delta kWh &= ((0.0315 * (106 - 45)) + (0.00617 * (62 - 4))) * 52.2 * 0.969 \\ &= 115 kWh \end{aligned}$$

**SUMMER COINCIDENT PEAK DEMAND SAVINGS**

N/A due to no savings attributable to standby losses between 1 and 5 PM.

---

<sup>1650</sup> Savings algorithm reconstructed from weekday and weekend savings information in Acker, Brad *et. al*, "Office Space Plug Load Profiles and Energy Saving Interventions," 2012 ACEEE Summer Study on Energy Efficiency in Buildings, and verified against savings in Acker *et. al* and savings in: BPA, "Smart Power Strip Energy Savings Evaluation: Ross Complex," (2011). Office stations are assumed to have zero or minimal standby losses during normal operating hours. Method shown in "Commercial Tier 1 APS Calculations – IL TRM.xlsx".

<sup>1651</sup> Based upon review of the PY2 and PY3 ComEd Direct Install Residential program surveys. This value could be modified based upon commercial application evaluation.

<sup>1652</sup> Based on survey data collected from ComEd 2018 and 2019 Small Business Kits Program. The 2018 ISR was 0.592 and the 2019 ISR was 0.835, the average being 0.71.



**FOSSIL FUEL SAVINGS**

N/A

**WATER AND OTHER NON-ENERGY IMPACT DESCRIPTIONS AND CALCULATION**

N/A

**DEEMED O&M COST ADJUSTMENT CALCULATION**

N/A

**MEASURE CODE: CI-MSC-APSC-V05-240101**

**REVIEW DEADLINE: 1/1/2028**

## 4.8.8 High Efficiency Transformer

### DESCRIPTION

Distribution transformers are used in commercial and industrial applications to step down power from distribution voltage to be used in HVAC or process loads (220V or 480V) or to serve plug loads (120V).

Distribution transformers that are more efficient than the required minimum federal standard efficiency qualify for this measure. If there is no specific standard efficiency requirement, the transformer does not qualify (because we cannot define a reasonable baseline). For example, although the federal standards increased the minimum required efficiency in 2016, most transformers with a NEMA premium or CEE Tier 2 rating will still achieve energy conservation. Standards are defined for low-voltage dry-type distribution transformers (up to 333kVA single-phase and 1000kVA 3-phase), liquid-immersed distribution transformers (up to 833kVA single-phase and 2500kVA 3-phase), and medium-voltage dry-type distribution transformers (up to 833kVA single-phase and 2500kVA 3-phase).

This measure was developed to be applicable to the following program types: TOS, NC.

If applied to other program types, the measure savings should be verified.

### DEFINITION OF EFFICIENT EQUIPMENT

Any transformer that is more efficient than the federal minimum standard. This includes CEE Tier II (single or three phase) and most NEMA premium efficiency rated products.

### DEFINITION OF BASELINE EQUIPMENT

A transformer that meets the minimum federal efficiency requirement should be used as the baseline to calculate savings. Standards are developed by the Department of Energy and published in the Federal Register 10CFR 431.<sup>1653</sup>

#### (a) *Low-Voltage Dry-Type Distribution Transformers.*

(2) The efficiency of a low-voltage dry-type distribution transformer manufactured on or after January 1, 2016, shall be no less than that required for their kVA rating in the table below. Low-voltage dry-type distribution transformers with kVA ratings not appearing in the table shall have their minimum efficiency level determined by linear interpolation of the kVA and efficiency values immediately above and below that kVA rating.

Single-phase		Three-phase	
kVA	Efficiency (%)	kVA	Efficiency (%)
15	97.70	15	97.89
25	98.00	30	98.23
37.5	98.20	45	98.40
50	98.30	75	98.60
75	98.50	112.5	98.74
100	98.60	150	98.83
167	98.70	225	98.94
250	98.80	300	99.02
333	98.90	500	99.14
		750	99.23
		1000	99.28

#### (b) *Liquid-Immersed Distribution Transformers.*

<sup>1653</sup> US Department of Energy, "Energy Conservation Program: Energy Conservation Standards for Distribution Transformers; Final Rule", 10 CFR Part 431, Published April 18, 2013, Compliance effective as of January 1, 2016.

(2) The efficiency of a liquid-immersed distribution transformer manufactured on or after January 1, 2016, shall be no less than that required for their kVA rating in the table below. Liquid-immersed distribution transformers with kVA ratings not appearing in the table shall have their minimum efficiency level determined by linear interpolation of the kVA and efficiency values immediately above and below that kVA rating.

Single-phase		Three-phase	
kVA	Efficiency (%)	kVA	Efficiency (%)
10	98.70	15	98.65
15	98.82	30	98.83
25	98.95	45	98.92
37.5	99.05	75	99.03
50	99.11	112.5	99.11
75	99.19	150	99.16
100	99.25	225	99.23
167	99.33	300	99.27
250	99.39	500	99.35
333	99.43	750	99.40
500	99.49	1000	99.43
667	99.52	1500	99.48
833	99.55	2000	99.51
		2500	99.53

**(c) Medium-Voltage Dry-Type Distribution Transformers.**

(2) The efficiency of a medium- voltage dry-type distribution transformer manufactured on or after January 1, 2016, shall be no less than that required for their kVA and BIL rating in the table below. Medium-voltage dry-type distribution transformers with kVA ratings not appearing in the table shall have their minimum efficiency level determined by linear interpolation of the kVA and efficiency values immediately above and below that kVA rating.

Single-phase				Three-phase			
kVA	BIL*			kVA	BIL		
	20-45 kV	46-95 kV	≥96 kV		20-45 kV	46-95 kV	≥96 kV
	Efficiency (%)	Efficiency (%)	Efficiency (%)		Efficiency (%)	Efficiency (%)	Efficiency (%)
15	98.10	97.86		15	97.50	97.18	
25	98.33	98.12		30	97.90	97.63	
37.5	98.49	98.30		45	98.10	97.86	
50	98.60	98.42		75	98.33	98.13	
75	98.73	98.57	98.53	112.5	98.52	98.36	
100	98.82	98.67	98.63	150	98.65	98.51	
167	98.96	98.83	98.80	225	98.82	98.69	98.57
250	99.07	98.95	98.91	300	98.93	98.81	98.69
333	99.14	99.03	98.99	500	99.09	98.99	98.89
500	99.22	99.12	99.09	750	99.21	99.12	99.02
667	99.27	99.18	99.15	1000	99.28	99.20	99.11
833	99.31	99.23	99.20	1500	99.37	99.30	99.21
				2000	99.43	99.36	99.28
				2500	99.47	99.41	99.33

**DEEMED LIFETIME OF EFFICIENT EQUIPMENT**

30 years<sup>1654</sup>

**DEEMED MEASURE COST**

Actual incremental costs should be used.

**LOADSHAPE**

Use custom loadshape based on application; default loadshape is Loadshape C67 (Ameren) or C68 (ComEd), which represent overall utility system loads.

**COINCIDENCE FACTOR**

Coincidence Factor for distribution transformers is 1.0 by definition. By including the load factor in the demand savings calculation, the load profile is accounted for.

---

**Algorithm**

---

**CALCULATION OF ENERGY SAVINGS**

Savings are determined by metering equipment

**ELECTRIC ENERGY SAVINGS**

$$\Delta kWh = Losses_{base} - Losses_{EE}$$

Where:

$$Losses_{base} = PowerRating * LF * PF * \left( \frac{1}{EFF_{base}} - 1 \right) * 8766$$

$$Losses_{EE} = PowerRating * LF * PF * \left( \frac{1}{EFF_{EE}} - 1 \right) * 8766$$

PowerRating = kVA rating of the transformer (in units of kVA)

EFF<sub>base</sub> = baseline total efficiency rating of federal minimum standard transformer (refer to baseline tables above based on kVA, voltage, and type of transformer)

EFF<sub>EE</sub> = actual total efficiency rating of the transformer as calculated by the appropriate DOE test method.<sup>1655</sup>

LF = Load Factor for the transformer. Ratio of average transformer load to peak load rating over a period of one year. Use actual load factor for the network segment served based on historical data. If unknown, use 22% for commercial load and 45% for industrial load.<sup>1656</sup>

PF = Power Factor for the load being served by the transformer. Ratio of real power to apparent power supplied to the transformer. Use actual power factor for the network segment served. If unknown, use 1.0 (unity) by default.<sup>1657</sup>

---

<sup>1654</sup> US DOE lists lifetime at 32 years. For consistency with efficiency measure evaluated lifetimes, 30 years is the recommended maximum deemed lifetime. US Department of Energy, “Energy Conservation Program: Energy Conservation Standards for Distribution Transformers; Final Rule”, 10 CFR Part 431, Published April 18, 2013, Effective as of January 1, 2016.

<sup>1655</sup> Energy Conservation Program: Test Procedures for Distribution Transformers; Final Rule. Effective May 30, 2006.

<sup>1656</sup> Guidelines on The Calculation and Use of Loss Factors, Electric Authority, Te Mana Hiko, February 14, 2013.

<sup>1657</sup> Unity power factor for used as default value, as used in the test procedures provided by US DOE. Energy Conservation Program: Test Procedures for Distribution Transformers; Final Rule. Effective May 30, 2006.

**SUMMER COINCIDENT PEAK DEMAND SAVINGS**

$$\Delta kW = \text{PowerRating} * \text{LF} * \text{PF} * \left( \frac{1}{\text{Eff}_{base}} - \frac{1}{\text{Eff}_{EE}} \right)$$

Variables as provided above.

**FOSSIL FUEL SAVINGS**

N/A

**WATER AND OTHER NON-ENERGY IMPACT DESCRIPTIONS AND CALCULATION**

N/A

**DEEMED O&M COST ADJUSTMENT CALCULATION**

N/A

**MEASURE CODE: CI-MSC-TRNS-V03-220101**

**REVIEW DEADLINE: 1/1/2025**

## 4.8.9 High Frequency Battery Chargers

### DESCRIPTION

This measure applies to industrial high frequency battery chargers, used for industrial equipment such as fork lifts, replacing existing SCR (silicon controlled rectifier) or ferroresonant charging technology. High frequency battery chargers have a greater system efficiency.

This measure was developed to be applicable to the following program types: TOS, NC. If applied to other program types, the measure savings should be verified.

### DEFINITION OF EFFICIENT EQUIPMENT

High frequency battery charger systems with minimum Power Conversion Efficiency of 90% and a minimum 8-hour shift operation five days per week.

### DEFINITION OF BASELINE EQUIPMENT

SCR or ferroresonant battery charger systems with minimum 8-hour shift operation five days per week.

### DEEMED LIFETIME OF EFFICIENT EQUIPMENT

15 years<sup>1658</sup>

### DEEMED MEASURE COST

The deemed incremental measure cost is \$400.<sup>1659</sup>

### LOADSHAPE

Loadshape C14 - Indust. 1-shift (8/5) (e.g., comp. air, lights)

Loadshape C15 - Indust. 2-shift (16/5) (e.g., comp. air, lights)

Loadshape C16 - Indust. 3-shift (24/5) (e.g., comp. air, lights)

Loadshape C17 - Indust. 4-shift (24/7) (e.g., comp. air, lights)

### COINCIDENCE FACTOR

The coincidence factor is assumed to be 0.0 for 1 and 2-shift operation and 1.0 for 3 and 4-shift operation.<sup>1660</sup>

---



---

### Algorithm

---



---

### ELECTRIC ENERGY SAVINGS

$$\Delta \text{kWh} = (\text{CAP} * \text{DOD}) * \text{CHG} * (\text{CR}_B / \text{PC}_B - \text{CR}_{EE} / \text{PC}_{EE})$$

Where:

CAP = Capacity of Battery

= Use actual battery capacity, otherwise use a default value of 35 kWh<sup>1661</sup>

DOD = Depth of Discharge

---

<sup>1658</sup> Suzanne Foster Porter et al., "Analysis of Standards Options for Battery Charger Systems", (PG&E, 2010), 45.

<sup>1659</sup> Suzanne Foster Porter et al., "Analysis of Standards Options for Battery Charger Systems", (PG&E, 2010), 42.

<sup>1660</sup> Emerging Technologies Program Application Assessment Report #0808, Industrial Battery Charger Energy Savings Opportunities, Pacific Gas & Electric. May 29, 2009.

<sup>1661</sup> Jacob V. Renquist, Brian Dickman, and Thomas H. Bradley, "Economic Comparison of fuel cell powered forklifts to battery powered forklifts", International Journal of Hydrogen Energy Volume 37, Issue 17, (2012): 2.

= Use actual depth of discharge, otherwise use a default value of 80%.<sup>1662</sup>

CHG = Number of Charges per year

= Use actual number of annual charges, if unknown use values below based on the type of operations<sup>1663</sup>

Standard Operations	Number of Charges per year
1-shift (8 hrs/day – 5 days/week)	520
2-shift (16 hrs/day – 5 days/week)	1040
3-shift (24 hrs/day – 5 days/week)	1560
4-shift (24 hrs/day – 7 days/week)	2184

CR<sub>B</sub> = Baseline Charge Return Factor

= 1.2485<sup>1664</sup>

PC<sub>B</sub> = Baseline Power Conversion Efficiency

= 0.84<sup>1665</sup>

CR<sub>EE</sub> = Efficient Charge Return Factor

= 1.107<sup>1666</sup>

PC<sub>EE</sub> = Efficient Power Conversion Efficiency

= 0.89<sup>1667</sup>

Default savings using defaults provided above are provided below:

Standard Operations	ΔkWh
1-shift (8 hrs/day – 5 days/week)	3,531
2-shift (16 hrs/day – 5 days/week)	7,061
3-shift (24 hrs/day – 5 days/week)	10,592
4-shift (24 hrs/day – 7 days/week)	14,829

**SUMMER COINCIDENT PEAK DEMAND SAVINGS**

$$\Delta kW = (PF_B/PC_B - PF_{EE}/PC_{EE}) * Volts_{DC} * Amps_{DC} / 1000 * CF$$

Where:

PF<sub>B</sub> = Power factor of baseline charger

= 0.9095<sup>1668</sup>

<sup>1662</sup> Ryan Matley, “Measuring Energy Efficiency Improvements in Industrial Battery Chargers”, (ESL-IE-09-05-32, Energy Technology Conference, New Orleans, LA, May 12-15, 2009), 4.

<sup>1663</sup> Number of charges is derived from the following reference and adjusted to the hours and days of the different types of shift operations. These values are based on an estimated 2-charge per 8-hour workday. See reference file Ryan Matley, “Measuring Energy Efficiency Improvements in Industrial Battery Chargers”, (ESL-IE-09-05-32, Energy Technology Conference, New Orleans, LA, May 12-15, 2009), 4.

<sup>1664</sup> Ryan Matley, “Measuring Energy Efficiency Improvements in Industrial Battery Chargers”, (ESL-IE-09-05-32, Energy Technology Conference, New Orleans, LA, May 12-15, 2009), 4 (average of SCR and Ferroresonant).

<sup>1665</sup> Ibid.

<sup>1666</sup> Ibid.

<sup>1667</sup> Ibid.

<sup>1668</sup> Ibid.

$PF_{EE}$  = Power factor of high frequency charger

= 0.9370<sup>1669</sup>

$Volts_{DC}$  = Actual DC rated voltage of charger (assumed baseline charger is replaced with same rated high frequency unit)

= Use actual battery DC voltage rating, otherwise use a default value of 48 volts.<sup>1670</sup>

$Amps_{DC}$  = Actual DC rated amperage of charger (assumed baseline charger is replaced with same rated high frequency unit)

= Use actual battery DC ampere rating, otherwise use a default value of 81 amps.<sup>1671</sup>

1,000 = watt to kilowatt conversion factor

CF = Summer Coincident Peak Factor for this measure

= 0.0 (for 1 and 2-shift operation)<sup>1672</sup>

= 1.0 (for 3 and 4-shift operation)<sup>1673</sup>

Other variables as provided above.

Default savings using defaults provided above are provided below:

Standard Operations	$\Delta kW$
1-shift (8 hrs/day – 5 days/week)	0
2-shift (16 hrs/day – 5 days/week)	0
3-shift (24 hrs/day – 5 days/week)	0.1165
4-shift (24 hrs/day – 7 days/week)	0.1165

**FOSSIL FUEL SAVINGS**

N/A

**WATER IMPACT DESCRIPTIONS AND CALCULATION**

N/A

**DEEMED O&M COST ADJUSTMENT CALCULATION**

N/A

**MEASURE CODE: CI-MSC-BACH-V02-210101**

**REVIEW DEADLINE: 1/1/2025**

<sup>1669</sup> Ibid.

<sup>1670</sup> Voltage rating based on the assumption of 35kWh battery with a normalized average amp-hour capacity of 760 Ah charged over a 7.5 hour charge cycle. Pacific Gas & Electric, “Emerging Technologies Program Application Assessment Report #0808”, Industrial Battery Charger Energy Savings Opportunities. May 29, 2009. Page 8, Table 3.

<sup>1671</sup> Ampere rating based on the assumption of 35kWh battery with a normalized average amp-hour capacity of 760 Ah charged over a 7.5 hour charge cycle. Pacific Gas & Electric, “Emerging Technologies Program Application Assessment Report #0808”, Industrial Battery Charger Energy Savings Opportunities. May 29, 2009. Page 8, Table 3.

<sup>1672</sup> Emerging Technologies Program Application Assessment Report #0808, Industrial Battery Charger Energy Savings Opportunities, Pacific Gas & Electric. May 29, 2009.

<sup>1673</sup> Ibid.



## 4.8.10 Commercial Clothes Dryer Moisture Sensor

### DESCRIPTION

This measure applies to moisture sensing controllers installed on new or existing commercial natural gas clothes dryers controlled electronically. Moisture controllers detect when the load is dry, which will stop the cycle from consuming additional energy. Some new commercial dryers utilize moisture sensors, but the majority of older dryers, as well as many new models, still do not utilize moisture sensors. In a commercial dryer, when a load is drying, the heat will run completely on in the early stages. Then, it begins to cycle on and off more frequently as the load becomes drier. Traditional moisture sensors use a conductivity strip in the dryer drum. The wet load will contact the strip that completes the circuit. When the load is dry, the circuit is shorted that completes the drying cycle. Instead, this technology is a “plug and play” retrofit controller that uses patent-pending software to determine when the load is dry. When the load is dry, it overrides the existing controls to end the cycle, which shuts the drying cycle. This measure does not apply to mechanical timer dryers or to dryers with modulating valves installed.

Natural gas energy savings will be achieved by reduced drying times and correspondingly reduced natural gas consumption. Electric savings will also be achieved by reduced operating times.

This measure was developed to be applicable to following facility types:

- Hotel/Motel
- Miscellaneous - Fitness and Recreational Sports Centers
- Hospital
- Assisted Living Facilities
- Miscellaneous - Dry cleaning
- Multifamily

Moisture sensing controller retrofits could create significant energy savings opportunities at other larger facility types with on-premise laundry operations (such as correctional facilities, universities, and staff laundries); however, the results included in this analysis are based heavily on past project data for the applicable facility types listed above and may not apply to facilities outside of this list due to variances in number of loads and average pound (lbs.) capacity per project site. Projects at these facilities should continue to be evaluated through custom programs and the applicable facility types and the resulting analysis should be updated based on new information.

This measure was developed to be applicable to the following program types: RF. If applied to other program types, the measure savings should be verified.

### DEFINITION OF EFFICIENT EQUIPMENT

A retrofit moisture controlling technology is added to new or existing commercial natural gas clothes dryers. Existing facilities must be able to confirm that they do not have moisture sensors (conductive strip type) or modulating gas valves installed on clothes dryers already before proceeding with the installation of this technology.

### DEFINITION OF BASELINE EQUIPMENT

The baseline equipment is a conventional natural gas clothes dryer without a moisture sensor or a modulating gas valve installed.

### DEEMED LIFETIME OF EFFICIENT EQUIPMENT

The equipment effective useful life (EUL) is 10 years.<sup>1674</sup>

---

<sup>1674</sup> Since this is a retrofit measure to an existing piece of equipment the measure life is less than the full life of the drier. Assumed to be 10 years as cost would be prohibitive for older machines that are likely to need replacing soon.

**DEEMED MEASURE COST**

The full retrofit cost is assumed to be \$600, including the material cost for the basic moisture control retrofit (\$500) and the associated labor for installation (\$100).<sup>1675</sup>

**LOADSHAPE**

Loadshape C55; Commercial Clothes Washer

**COINCIDENCE FACTOR**

The coincidence factor for this measure is dependent on the application:

Application	Coincidence Factor <sup>1676</sup>
Multi-family Dryers	0.15
On-Premise Laundromats	0.52

---

**Algorithm**

---

**CALCULATION OF ENERGY SAVINGS**

**ELECTRIC ENERGY SAVINGS**

Electric energy savings are per retrofitted dryer.

$$\Delta kWh = N_{Cycles} * SF$$

Where:

$N_{Cycles}$  = Number of dryer cycles per year. Refer to the table below if this value is not directly available from the facility.

Application	Cycles per Dryer Per Year
Multi-family Dryers <sup>1677</sup>	1,074
On-Premise Laundromats <sup>1678</sup>	3,607

SF = Savings factor  
 = 0.16 kWh/cycle<sup>1679</sup>

If using default cycles the savings are as follows:

Application	$\Delta kWh$ per Dryer
Multi-family Dryers	171.8
On-Premise Laundromats	577.1

<sup>1675</sup> Based on Gas Technology Institute’s analysis of cost data from “Nicor Gas Emerging Technology Program, 1069: Moisture Sensor Retrofit, Comprehensive Pilot Assessment Report,” May 1, 2017.

<sup>1676</sup> In the absence of loadshape information for commercial applications, this is estimated by adjusting the residential coincidence factor proportionately by the relative number of loads (264 for residential and as described in this measure for commercial applications).

<sup>1677</sup> From DOE’s Federal Register Notices - found here: <http://energy.gov/eere/buildings/recent-federal-register-notice>

<sup>1678</sup> Average value for dryer cycles in healthcare facility, hotels, drycleaners and laundromats from tests conducted in Nicor Gas Emerging Technology Program’s Commercial Dryer Modulation Retrofit Public Project Report.

<sup>1679</sup> Savings factor based on engineering analysis of savings data from “Nicor Gas Emerging Technology Program, 1069: Moisture Sensor Retrofit, Comprehensive Pilot Assessment Report,” May 1, 2017 and “Advanced Commercial Clothes Dryer Technologies Field Test,” prepared by Gas Technology Institute for the Minnesota Department of Commerce, January 15, 2018.

**SUMMER COINCIDENT PEAK DEMAND SAVINGS**

$$\Delta kW = \Delta kWh / \text{Hours} * CF$$

Where:

Hours = Assumed Run hours of Clothes Dryer<sup>1680</sup>

Application	Hours
Multi-family Dryers	806
On-Premise Laundromats	2,705

CF = Summer Peak Coincidence Factor for measure.

Application	Coincidence Factor <sup>1681</sup>
Multi-family Dryers	0.15
On-Premise Laundromats	0.52

If using default cycles the savings are as follows:

Application	$\Delta kW$ per Dryer
Multi-family Dryers	0.0320
On-Premise Laundromats	0.1109

**FOSSIL FUEL SAVINGS**

Natural gas savings are per retrofitted dryer.

$$\Delta \text{Therms} = N_{\text{Cycles}} * SF$$

Where:

SF = Savings factor  
 = 0.15 therms/cycle<sup>1682</sup>

If using default cycles the savings are as follows:

Application	$\Delta \text{Therms}$ per Dryer
Multi-family Dryers	161
On-Premise Laundromats	541

**WATER AND OTHER NON-ENERGY IMPACT DESCRIPTIONS AND CALCULATION**

N/A

**DEEMED O&M COST ADJUSTMENT CALCULATION**

N/A

<sup>1680</sup> Estimate based on 45 minutes per cycle.

<sup>1681</sup> In the absence of loadshape information for commercial applications, this is estimated by adjusting the residential coincidence factor proportionately by the relative number of loads (264 for residential and as described in this measure for commercial applications).

<sup>1682</sup> Savings factor based on engineering analysis of savings data from “Nicor Gas Emerging Technology Program, 1069: Moisture Sensor Retrofit, Comprehensive Pilot Assessment Report,” May 1, 2017 and “Advanced Commercial Clothes Dryer Technologies Field Test,” prepared by Gas Technology Institute for the Minnesota Department of Commerce, January 15, 2018.

**MEASURE CODE: CI-MSC-CDMS-V02-230101**

**REVIEW DEADLINE: 1/1/2027**

## 4.8.11 Efficient Thermal Oxidizers

### DESCRIPTION

Thermal oxidizers are used to destroy volatile organic compounds (VOCs) from process exhausts, before emitting the treated air to the environment. VOC emissions are precursors to the formation of ground-level ozone pollution, and its control is mandated by the U.S. EPA. Some VOC constituents are individually toxic and require efficient destruction. Some waste streams have high enough concentrations to present an explosion hazard. Other waste streams merely present nuisance odors that need to be mitigated.

A facility may be required to utilize a thermal oxidizer by a state regulatory agency air quality permit. Some permits may require a VOC destruction efficiency that must be demonstrated with periodic emissions testing. Other permits merely require maintaining an oxidizer chamber temperature. A facility may also choose to utilize a thermal oxidizer for other purposes (nuisance odors) without a regulatory requirement.

The Efficient Thermal Oxidizer measure seeks to evaluate fossil fuel savings from utilizing more efficient means for VOC destruction with the use of a recuperative or regenerative thermal oxidizer. The heat recovery (either recuperative or regenerative) is used to pre-heat the inlet process air stream. This primary heat recovery is used within the thermal oxidizer process and the only heat recovery that is covered in this measure protocol. Fossil fuel savings will result from reduced burner firing. There is a “secondary” form of heat recovery that recovers heat from the combustion exhaust stack for other purposes like space heating, DHW heating, etc.

### DEFINITION OF EFFICIENT EQUIPMENT

Two thermal oxidizer technologies can be considered as efficient equipment: recuperative and regenerative.

#### Recuperative Thermal Oxidizer

In a recuperative thermal oxidizer, the exhaust air stream is sent through a heat exchanger to indirectly pre-heat the inlet air stream coming from the process. The heat exchanger efficiency for a recuperator is typically 50-70%.<sup>1683</sup> The chamber temperature is typically 1,400°F to 1,500°F.

#### Regenerative Thermal Oxidizer

A regenerative thermal oxidizer utilizes a two-chamber ceramic bed as its heat exchanger system. The exhaust air passes through one bed, imparting its heat onto the ceramic media, while the intake air passes through the other bed, capturing the waste heat from the previous cycle. The flow reverses every few minutes so that the intake bed becomes the exhausted bed and vice versa. The heat exchanger efficiency of a regenerative system is much higher than a recuperative system. These efficiencies can reach 85% to 97%.<sup>1684</sup> However, the ceramic media needs to be periodically cleaned or replaced. The chamber temperatures in regenerative thermal oxidizers are typically 1,500°F to 1,600°F (depending on VOC requirements).

### DEFINITION OF BASELINE EQUIPMENT

Depending on the facility process, there may be two baseline selection options: incinerator or recuperator.

The baseline thermal oxidizer with no heat recovery is referred to as an incinerator. This baseline is recommended for selection if it currently exists on site or in new construction when there is a specific process that cannot practically utilize a recuperator due to VOCs coating or clogging the heat exchanger. This system employs a burner to provide direct fire to a process exhaust air stream. Typical operative temperatures are 1,400°F to 2,200°F. The advantage of an afterburner is a quick startup and shutdown time that is ready on demand. The equipment cost is lower than the efficient equipment, but the fuel consumption is much higher.

---

<sup>1683</sup> Presentation on the “Operating Cost Reduction Strategies for Oxidizers”, presented by Rich Grzanka, during the Chem Show Technology Exposition on October 31, 2007.

<sup>1684</sup> Ibid.

In all other cases (existing equipment is recuperative or new construction/ expansion of manufacturing process), a recuperative thermal oxidizer is recommended as the appropriate baseline.

**DEEMED LIFETIME OF EFFICIENT EQUIPMENT**

The expected useful life of any thermal oxidizer system is assumed to 20 years.<sup>1685</sup>

**DEEMED MEASURE COST**

The cost of any thermal oxidizer is dependent on various variables such as air flow capacity, destruction efficiency, heat exchanger efficiency, etc.<sup>1686</sup> Shown below is an example of a system for 20,000 cfm.

Recuperative thermal oxidizer costs, based on their heat recovery efficiency, are detailed in the table below.

Heat Recovery Efficiency	Equipment Cost
0%	\$106,042
35%	\$174,193
50%	\$203,801
70%	\$253,801
Average	\$184,317

A regenerative thermal oxidizer at 95% heat recovery has a deemed cost of \$546,000.

Incinerator cost is treated as 0% heat recovery in the recuperative cost summary table above and has a deemed cost of \$106,042.

**LOADSHAPE**

N/A

**COINCIDENCE FACTOR**

N/A

---

**Algorithm**

---

**CALCULATION OF ENERGY SAVINGS**

Energy savings from thermally efficient equipment are entirely fossil fuel related. There are no electricity savings nor peak demand savings, as the blower fans and valve actuators are assumed to operate the same in all conditions.

**ELECTRIC ENERGY SAVINGS**

N/A

**SUMMER COINCIDENT PEAK DEMAND SAVINGS**

N/A

**FOSSIL FUEL SAVINGS**

$$\Delta\text{Therms} = ((\text{Baseline QT Air Pollution Control Device} - \text{Proposed QT Air Pollution Control Device}) \times \text{Hours}) / \text{LHV}$$

Where:

---

<sup>1685</sup> EPA Air Pollution Control Cost Manual, Chapter 2, November 2017. The system capital recovery cost is based on an estimated 20-year equipment life. This estimate of oxidizer equipment life is consistent with information available to EPA and is consistent with statements from large vendors for incinerators and oxidizers.

<sup>1686</sup> U.S. Environmental Protection Agency, Incinerators and Oxidizers, Chapter 2, November 2017.

- LHV = Latent Heat of Vaporization
- = If the post is regenerative thermal oxidizer, LHV = 0.953.
- = If the post is recuperative thermal oxidizer, LHV = 1.

Regenerative or Recuperative: A baseline or proposed regenerative or recuperative air pollution control device can each be modeled in the following heat balance equation:<sup>1687</sup>

$$Q_T \text{ (btuh)} = Q_i + Q_{CC} + Q_{RL} - Q_{VOC}$$

Incinerator: A baseline incinerator air pollution control device can be modeled as the following heat balance equation:

$$Q_T \text{ (btuh)} = Q_i + Q_{CC} + Q_{RL}$$

Where:

- $Q_T$  = Total Energy Input
- $Q_i$  = Energy (btuh) used to raise the temperature of process air ( $F_i$ )
- $Q_{CC}$  = Heat (btuh) used to raise the temperature of combustion air ( $F_{CC}$ )
- $Q_{RL}$  = Radiation heat loss (btuh) from RTO
- $Q_{VOC}$  = Heat release (btuh) provided by VOC combustion
- Hours = Annual hours per year that oxidizer is used

Where:

$$Q_i = F_i * 1.08 * (T_o - T_i)$$

$T_o$  = Average stack outlet temperature (°F) (actual trended average or use efficiency equation below to solve for  $T_o$  under assumed conditions)

$$T_o = T_c - (N * (T_c - T_i) * F_i / (F_i + F_{CC}))$$

$T_c$  = Combustion chamber temperature (°F), trended or design value provided by the manufacturer

$N$  = Thermal Efficiency of Heat Exchanger

Thermal Oxidizer	Efficiency
Regenerative	97%
Recuperative	70%
Incinerator	0%

$T_i$  = Inlet air temperature (°F), this is the temperature of the air coming from the process

$F_i$  = Process air flow (cfm), actual loading or use maximum design value

1.08 = Conversion Factor

= 60 (min/hr) \* 0.07489 (lb/ft<sup>3</sup>, density air at standard conditions) \* 0.2404 btu/°F-lb, (specific heat of air), where 0.2404 is average heat capacity of intake air

Where:

$$Q_{CC} = F_{CC} * 1.08 * (T_o - T_A)$$

$F_{CC}$  = Additional combustion air flow (cfm) at provided  $F_i$  value

<sup>1687</sup> ICAC Guidance Method for Estimation of Gas Consumption in a Regenerative Thermal Oxidizer (RTO), July 2002.

= If unknown, assume 3% of design value<sup>1688</sup>

$T_o$  = Average outlet temperature (°F) (same as above)

$T_A$  = Combustion intake air temperature (°F)

= Indoor: Actual, or assume 70 °F year-round

= Outdoor: Actual annual average found near the facility, or assume TMY3 annual averages:

Region / Area	Average Outdoor Air Temperature (°F)
Chicago O'Hare	50.0
Chicago Midway	52.5
Rockford Airport	47.6

Where:

$$Q_{RL} = SA * HLF$$

SA = Surface Area (ft<sup>2</sup>) (provided by the manufacturer or rough measurements taken)

HLF = Assume a heat loss factor of 240 btuh/ft<sup>2</sup> if installed outdoors; otherwise, 0 btuh/ft<sup>2</sup> for indoor installation since the waste heat provides space heating and offset gas-fired space heating equipment

Where:

$$Q_{VOC} = VOC * HC * (\%Dest / 100)$$

VOC = Average lbs/hr from process to oxidizer

HC = btu/lb, weighted average for the heat of combustion of VOCS  
= Site-specific, lookup table

%Dest = Destruction efficiency of VOCs provided by the manufacturer, or use:

Hours = Annual hours of operation of the air pollution control device, assume customer production schedule or hours of occupancy

LHV = Lower heating value of natural gas  
= 983 btu/CF<sup>1689</sup>

HHV = High heating value of natural gas  
= 1,031 btu/CF<sup>1690</sup>

0.953 = LHV / HHV conversion factor

To calculate the fossil fuel savings by upgrading from an incinerator to an efficient thermal oxidizer system, the new temperatures must be considered. The addition of heat recovery (either recuperative or regenerative) will increase the inlet temperature,  $T_i$ , above that found in the facility.

The calculation should consider changes in the inlet temperature. First, the key temperature required for 99.99% destruction efficiency of various VOC compounds must be determined. The U.S. EPA's Innovative Strategies and Economics Group produced some guidance on the key temperatures<sup>1691</sup> for the following compounds:

<sup>1688</sup> Ibid.

<sup>1689</sup> Biomass Energy Data Book, 2011, Appendix A: Lower and Higher Heating Values of Gas, Liquid, and Solid Fuels.

<sup>1690</sup> Heat content of natural gas delivered to consumers per the Energy Information Administration, Independent Statistics & Analysis, 2018.

<sup>1691</sup> U.S. Environmental Protection Agency, Incinerators and Oxidizers, Chapter 2, November 2017.



VOC Compound	Key Destruction Temperature (°F)
Acrylonitrile	1,344
Allyl chloride	1,276
Benzene	1,350
Chlorobenzene	1,407
1,2 – dichloromethane	1,368
Methyl chloride	1,596
Toluene	1,341
Vinyl chloride	1,369

For VOC compounds not listed above, the Key Destruction Temperature should be determined through product literature, equipment vendors, Material Data Safety Sheets (MSDS), or some other source.

When employing heat recovery, either recuperative or regenerative, the increased outlet temperature is limited to the heat exchanger efficiency. This efficiency, or in other words how much heat can be recovered, is limited to the auto-ignition temperatures of the VOCs in the air stream. Regenerative thermal oxidizers offer the advantage of recovering more heat as the combustion can occur within the heat exchanger, whereas with recuperative thermal oxidizers, the heat exchanger efficiency is much lower to prevent premature combustion in the stack of the recuperator.

While the VOCs in the waste air stream have some heating value that contributes to reaching the required chamber temperature, such contributions do not have as high of an impact in the overall energy consumption calculation when compared to the heat exchanger efficiency.

#### **WATER AND OTHER NON-ENERGY IMPACT DESCRIPTIONS AND CALCULATION**

Thermal oxidizer operations will have no impact on water or other resources. There may be some safety issues with potential burning hazards from deploying this equipment at high temperatures. There may also be some potential issues with installing outdoor natural gas piping to the location of the thermal oxidizers. In terms of physical sizing, regenerative thermal oxidizers are much larger, thus requiring larger physical space at the site of installation.

#### **DEEMED O&M COST ADJUSTMENT CALCULATION**

The ceramic media in the regenerative thermal oxidizer requires regular servicing and may need to be considered as a regular part of facility O&M.

**MEASURE CODE: CI-MS-ETOX-V02-230101**

**REVIEW DEADLINE: 1/1/2027**

## 4.8.12 Spring-Loaded Garage Door Hinge

### DESCRIPTION

Existing overhead doors often close loosely at the perimeter weather strips and between panels. Conditioned air escapes through these gaps, leading to energy loss. Spring-loaded hinges create tension and reduce gaps at the perimeter and between panels. The product is applicable for small-commercial and residential sectors, but the savings estimated by this measure apply only to small-commercial applications. This measure applies to sites where the inside area of the garage is conditioned during the heating season by natural gas.

This measure was developed to be applicable to the following program types: NC, RF. If applied to other program types, the measure savings should be verified as a custom measure.

### DEFINITION OF EFFICIENT EQUIPMENT

The efficient equipment consists of a heavy-duty spring-loaded hinge installed in place of a standard hinge on a garage overhead door. The number of hinges per project may vary depending on the door type, size, and number of panels. The efficient condition is an air sealed garage door with no gaps around the perimeter or between panels.

### DEFINITION OF BASELINE EQUIPMENT

The baseline equipment is a garage door with a 1/8-inch gap between the door and the weather-stripping around the perimeter of the door. The bottom of the door is assumed sealed.

### DEEMED LIFETIME OF EFFICIENT EQUIPMENT

The expected measure life is assumed to be 20 years.<sup>1692</sup>

### DEEMED MEASURE COST

Incremental costs equal installed cost and will vary based on the number of hinges required per door. Based on information provided by the manufacturer to Nicor Gas, average material cost is \$126 per garage door and installation cost is \$63 per garage door for a total installed cost of \$189 per garage door. The typical garage door is assumed to have 4 panels and 9 total hinges.

### LOADSHAPE

N/A

### COINCIDENCE FACTOR

N/A

---

### Algorithm

---

### CALCULATION OF ENERGY SAVINGS

Savings are calculated based on a reduction in airflow rate associated with decreased infiltration across the leakage area. The algorithm below for change in cubic feet per minute,  $\Delta CFM$ , is modeled after equation 48 in Chapter 16: Ventilation and infiltration of the 2017 ASHRAE Handbook—Fundamentals.

### ELECTRIC ENERGY SAVINGS

N/A

---

<sup>1692</sup> Public Service Commission of Wisconsin, "Evaluation – Business Program: Measure Life Study," Focus on Energy (2009): page 1-4, Table 1-2 Recommended Measure Life by WISEerts Group Description for Building Shell Equip or Tech measure type, accessed March 26, 2019, [https://focusonenergy.com/sites/default/files/bpmeasurelifestudyfinal\\_evaluationreport.pdf](https://focusonenergy.com/sites/default/files/bpmeasurelifestudyfinal_evaluationreport.pdf).

**SUMMER COINCIDENT PEAK DEMAND SAVINGS**

N/A

**FOSSIL FUEL SAVINGS**

$$\Delta CFM = A_l * [(C_s * \Delta T) + (C_w * W_s^2)]^{0.5}$$

$$\Delta HeatLoad = \Delta CFM * Conv_{min} * Density_{air} * SpecificHeat_{air} * \Delta T$$

$$\Delta therms_{Hr} = \Delta HeatLoad / Eff_{heat} / Conv_{BTU}$$

$$\Delta therms_{Ann} = \Delta therms_{Hr} * Hours$$

Where:

- $A_l$  = Leakage area, estimated at 51 (in<sup>2</sup>), of air gap before retrofit. <sup>1693</sup>
- $C_s$  = Stack coefficient, 0.0299 (cfm<sup>2</sup>/in<sup>4</sup> \* °F), adjustment based on airflow at average building height. <sup>1694</sup>
- $C_w$  = Wind coefficient, 0.0086 (cfm<sup>2</sup>/in<sup>4</sup> \* mph<sup>2</sup>), adjustment based on airflow at average building height and wind shelter classification. <sup>1695</sup>
- $\Delta T$  = Average temperature difference between outside air temperature (OAT) during the heating season <sup>1696</sup> and assumed indoor heating temperature setpoint 70°F; <sup>1697</sup> see table below.
- $W_s$  = Average wind speed (mph) during heating season, see table below.

Climate Zone	Average OAT, Heating (°F)	Average Delta T, Heating (°F)	Average heating Season Wind Speed (mph) <sup>1698</sup>
1 (Rockford)	32	38	10
2 (Chicago)	34	36	10
3 (Springfield)	35	35	10
4 (Belleville)	36	34	9
5 (Marion)	39	31	7

- $Conv_{min}$  = Conversion from minutes to hours, 60 minutes/hour.
- $Density_{air}$  = The density of air, 0.08 (lb/ft<sup>3</sup>) at 1 atmosphere pressure and approximately 30-40°F. <sup>1699</sup>

<sup>1693</sup> Leakage area is estimated based on average door size of installations previously completed in Wisconsin and reported in the Wisconsin Focus on Energy Technical Reference Manual. Average door size is 10 ft x 12 ft, with a side and top perimeter equal to 1 top \* (10 ft \* 12 in/1 ft) + 2 sides\* (12 ft \* 12 in/1ft) = 408 in. At 1/8 in perimeter gap, the leakage area is 408 in \* 1/8 in = 51 in<sup>2</sup>.

<sup>1694</sup> 2017 ASHRAE Handbook—Fundamentals, 16.24, Table 4 “Basic Model Stack Coefficient  $C_s$ ”, assumed average building height of 16 feet, two-story.

<sup>1695</sup> 2017 ASHRAE Handbook—Fundamentals, 16.24, Table 6 “Basic Model Wind Coefficient  $C_w$ ”, assumed average building height of 16 feet and shelter class 3: “Typical shelter caused by other buildings across street from building under study.”

<sup>1696</sup> DOE Weather Data, TMY3 (Typical Meteorological Year), developed by NREL, for the average outdoor temperature when the heating system is expected to be operating.

<sup>1697</sup> Energy Center of Wisconsin, “Baseline Building Energy Models – Nonresidential Heating Thermostat Setpoint,” ComEd Portfolio Modeling Report (July 2010): page 6.

<sup>1698</sup> DOE Weather Data, TMY3 (Typical Meteorological Year), developed by NREL, for the average wind speed when the heating system is expected to be operating, defined as hours where the average temperature is lower than 55°F.

<sup>1699</sup> Engineering ToolBox, (2003). Air - Density, Specific Weight and Thermal Expansion Coefficient at Varying Temperature and Constant Pressures. [online] Available at: [https://www.engineeringtoolbox.com/air-density-specific-weight-d\\_600.html](https://www.engineeringtoolbox.com/air-density-specific-weight-d_600.html) [Accessed March 2019].

$SpecificHeat_{air}$  = Specific heat of air, 0.24 (BTU/lb) at 1 atmosphere pressure and 32°F.<sup>1700</sup>

$Eff_{heat}$  = Efficiency of the heating system, assume 0.78 for planning purposes.<sup>1701</sup>

$Conv_{BTU}$  = Conversion from BTUs to therms, 100,000 BTU/therm.

$EFLH_H$  =Equivalent Full Load Heating Hours in Existing Buildings or New Construction are listed in section 4.4 HVAC End Use, but a subset of the building types most likely to use this measure are repeated here for easy reference.

EFLH Existing Buildings					
Building Type	Zone 1 (Rockford)	Zone 2 (Chicago)	Zone 3 (Springfield)	Zone 4 (Belleville)	Zone 5 (Marion)
Convenience Store	1,481	1,368	1,214	871	973
Garage	958	969	852	680	1,047
High School	1,845	1,857	1,666	1,187	1,388
Manufacturing	1,048	1,013	939	567	634
Office - Low Rise	1,428	1,425	1,132	692	793
Retail - Strip Mall	1,347	1,325	1,183	1,064	1,096
Warehouse	1,285	1,286	1,180	1,147	1,224

EFLH New Construction					
Building Type	Zone 1 (Rockford)	Zone 2 (Chicago)	Zone 3 (Springfield)	Zone 4 (Belleville)	Zone 5 (Marion)
Convenience Store	1,481	1,368	1,214	871	973
Garage	958	969	852	680	1,047
High School	1,807	1,642	2,093	2,292	1,830
Manufacturing	1,048	1,013	939	567	634
Office - Low Rise	947	989	1,090	1,302	1,076
Retail - Strip Mall	722	789	667	834	911
Warehouse	389	522	408	527	567

Savings for all climate zones and selected building types are presented in the following table.

Annual Therm Savings Existing Buildings					
Building Type	Zone 1 (Rockford)	Zone 2 (Chicago)	Zone 3 (Springfield)	Zone 4 (Belleville)	Zone 5 (Marion)
Convenience Store	59.89	51.62	44.19	29.20	26.38
Garage	38.74	36.56	31.01	22.79	28.39
High School	74.61	70.07	60.64	39.79	37.63
Manufacturing	42.38	38.22	34.18	19.01	17.19
Office - Low Rise	57.75	53.77	41.21	23.20	21.50
Retail - Strip Mall	54.47	50.00	43.06	35.67	29.72

<sup>1700</sup> Engineering ToolBox, (2004). Air - Specific Heat at Constant Pressure and Varying Temperature. [online] Available at: [https://www.engineeringtoolbox.com/air-specific-heat-capacity-d\\_705.html](https://www.engineeringtoolbox.com/air-specific-heat-capacity-d_705.html) [Accessed March 2019].

<sup>1701</sup> To maintain consistency across assumptions within the IL TRM, this value is equal to the furnace efficiency value listed in 4.8.2 Roof Insulation for C&I Facilities measure.

Annual Therm Savings Existing Buildings					
Building Type	Zone 1 (Rockford)	Zone 2 (Chicago)	Zone 3 (Springfield)	Zone 4 (Belleville)	Zone 5 (Marion)
Warehouse	51.97	48.53	42.95	38.45	33.19

Annual Therm Savings New Construction					
Building Type	Zone 1 (Rockford)	Zone 2 (Chicago)	Zone 3 (Springfield)	Zone 4 (Belleville)	Zone 5 (Marion)
Convenience Store	59.89	51.62	44.19	29.20	26.38
Garage	38.74	36.56	31.01	22.79	28.39
High School	73.08	61.96	76.19	76.83	49.62
Manufacturing	42.38	38.22	34.18	19.01	17.19
Office - Low Rise	38.30	37.32	39.68	43.64	29.17
Retail - Strip Mall	29.20	29.77	24.28	27.96	24.70
Warehouse	15.73	19.70	14.85	17.67	15.37

Savings for all climate zones and selected building types per linear foot are presented in the following table.

Annual Therm Savings per Linear Foot Existing Buildings					
Building Type	Zone 1 (Rockford)	Zone 2 (Chicago)	Zone 3 (Springfield)	Zone 4 (Belleville)	Zone 5 (Marion)
Convenience Store	1.76	1.52	1.30	0.86	0.78
Garage	1.14	1.08	0.91	0.67	0.83
High School	2.19	2.06	1.78	1.17	1.11
Manufacturing	1.25	1.12	1.01	0.56	0.51
Office - Low Rise	1.70	1.58	1.21	0.68	0.63
Retail - Strip Mall	1.60	1.47	1.27	1.05	0.87
Warehouse	1.53	1.43	1.26	1.13	0.98

Annual Therm Savings per Linear Foot New Construction					
Building Type	Zone 1 (Rockford)	Zone 2 (Chicago)	Zone 3 (Springfield)	Zone 4 (Belleville)	Zone 5 (Marion)
Convenience Store	1.76	1.52	1.30	0.86	0.78
Garage	1.14	1.08	0.91	0.67	0.83
High School	2.15	1.82	2.24	2.26	1.46
Manufacturing	1.25	1.12	1.01	0.56	0.51
Office - Low Rise	1.13	1.10	1.17	1.28	0.86
Retail - Strip Mall	0.86	0.88	0.71	0.82	0.73
Warehouse	0.46	0.58	0.44	0.52	0.45

**WATER AND OTHER NON-ENERGY IMPACT DESCRIPTIONS AND CALCULATION**

N/A

**DEEMED O&M COST ADJUSTMENT CALCULATION**

N/A

**MEASURE CODE: CI-MSC-SLDH-V01-200101**

**REVIEW DEADLINE: 1/1/2026**

### 4.8.13 Variable Speed Drives for Process Fans

#### DESCRIPTION

This measure is applied to variable speed drives (VSD) which are installed on non-HVAC fans for process loads. There are separate measures for HVAC pumps and cooling tower fans (4.4.17) and HVAC supply and return fans (4.4.26). VSD process pump applications require custom analysis by the program administrator. The VSD will modulate the speed of the motor when it does not need to run at full load. Since the power of the motor is proportional to the cube of the speed for these types of applications, significant energy savings will result.

This measure was developed to be applicable to the following program types: TOS, RF. If applied to other program types, the measure savings should be verified.

#### DEFINITION OF EFFICIENT EQUIPMENT

The VSD is applied to a motor which does not have a VSD. The application must have a variable load and installation is to include the necessary controls. Savings are based on application of VSDs to a range of baseline load conditions including no control, inlet guide vanes, outlet guide vanes and throttling valves.

#### DEFINITION OF BASELINE EQUIPMENT

The time of sale baseline is a new motor installed without a VSD or other methods of control. Retrofit baseline is an existing motor operating without a method of variable control. This information shall be collected from the customer.

Installations of new equipment with VSDs which are required by IECC, the energy code as adopted by the State of Illinois are not eligible for incentives.

Note, IECC 2021 is expected to become effective statewide in 2023. IECC 2018 is the requisite code for any projects with permitting dates spanning July 1, 2019 to the IECC 2021 effective date. Prior to July 1, 2019, IECC 2015 is the applicable code. As code requirements and adoption can differ from municipality to municipality, the user should verify which version of code is applicable given these constraints.

#### DEEMED LIFETIME OF EFFICIENT EQUIPMENT

The expected measure life is 15 years.<sup>1702</sup>

#### DEEMED MEASURE COST

The costs vary based on the motor horsepower and application. Actual costs should be used. For default cost estimates, please see table below.<sup>1703</sup>

HP	Cost
5 HP	\$2,147
10 HP	\$2,494
15 HP	\$3,940
20 HP	\$4,389
25 HP	\$4,839
30 HP	\$5,289
40 HP	\$6,188
50 HP	\$7,088

<sup>1702</sup> ComEd Effective Useful Life Research Report (2018), Navigant, May 14, 2018

<sup>1703</sup> Default incremental costs are sourced from NEEP Incremental Cost Study (ICS) – Phase II Final Report, Navigant, 2013. The VFD costs from the NEEP ICS was further manipulated in 2017 by iTron to account for inflation, other jurisdictions, and other horsepower and application considerations. The default incremental costs assume an average between VFDs with and without bypasses and adjusted to 2023 values to account for inflation.

HP	Cost
60 HP	\$8,463
75 HP	\$9,552
100 HP	\$11,365

**LOADSHAPE**

Time-based schedule considerations are required to perform energy savings calculations and should be concurrently used to establish the savings loadshape that is in alignment with relevant loadshape components and definitions.

**COINCIDENCE FACTOR**

The demand savings factor (DSF) is already based upon coincident savings, and thus there is no additional coincidence factor for this characterization.

---



---

**Algorithm**

---



---

**CALCULATION OF SAVINGS**

**ELECTRIC ENERGY SAVINGS**

$$kWh_{Base} = \left( 0.746 \times HP \times \frac{LF}{\eta_{motor}} \right) \times RHRS \times \sum_{0\%}^{100\%} (\%FF \times PLR_{Base})$$

$$kWh_{Retrofit} = \left( 0.746 \times HP \times \frac{LF}{\eta_{motor}} \right) \times RHRS \times \sum_{0\%}^{100\%} (\%FF \times PLR_{Retrofit})$$

$$ESF = (kWh_{Base} - kWh_{Retrofit}) / kWh_{Base}$$

$$\Delta kWh_{total} = kWh_{Base} \times ESF$$

Where:

$kWh_{Base}$  = Baseline annual energy consumption (kWh/yr)

$kWh_{Retrofit}$  = Retrofit annual energy consumption (kWh/yr)

$ESF$  = Energy savings factor; If ESF is greater than 67%, cap the ESF at 67% for process fan VSD improvements.<sup>1704</sup>

$\Delta kWh_{total}$  = Total project annual energy savings

0.746 = Conversion factor for HP to kWh

$HP$  = Nominal horsepower of controlled motor

$LF$  = Load Factor; Motor Load at Fan Design CFM (Default = 65%)<sup>1705</sup>

$\eta_{motor}$  = Installed nominal/nameplate motor efficiency

= Default motor is a NEMA Premium Efficiency, ODP, 4-pole/1800 RPM fan motor

<sup>1704</sup> Recommendations for Verifying Savings for non-HVAC VFDs memorandum calculated an energy savings limit of 67% for process fans using the Toshiba Energy Savings Software for Motors and Drives (2009 version).

<sup>1705</sup> Lawrence Berkeley National Laboratory, and Resource Dynamics Corporation. (2008). "Improving Motor and Drive System Performance; A Sourcebook for Industry". U.S. Department of Energy, Office of Energy Efficiency and Renewable Energy. Golden, CO: National Renewable Energy Laboratory.



**NEMA Premium Efficiency Motors Default Efficiencies<sup>1706</sup>**

Size HP	Open Drip Proof (ODP)			Totally Enclosed Fan-Cooled (TEFC)		
	# of Poles			# of Poles		
	6	4	2	6	4	2
	Speed (RPM)			Speed (RPM)		
	1200	1800 Default	3600	1200	1800	3600
1	0.825	0.855	0.770	0.825	0.855	0.770
1.5	0.865	0.865	0.840	0.875	0.865	0.840
2	0.875	0.865	0.855	0.885	0.865	0.855
3	0.885	0.895	0.855	0.895	0.895	0.865
5	0.895	0.895	0.865	0.895	0.895	0.885
7.5	0.902	0.910	0.885	0.910	0.917	0.895
10	0.917	0.917	0.895	0.910	0.917	0.902
15	0.917	0.930	0.902	0.917	0.924	0.910
20	0.924	0.930	0.910	0.917	0.930	0.910
25	0.930	0.936	0.917	0.930	0.936	0.917
30	0.936	0.941	0.917	0.930	0.936	0.917
40	0.941	0.941	0.924	0.941	0.941	0.924
50	0.941	0.945	0.930	0.941	0.945	0.930
60	0.945	0.950	0.936	0.945	0.950	0.936
75	0.945	0.950	0.936	0.945	0.954	0.936
100	0.950	0.954	0.936	0.950	0.954	0.941
125	0.950	0.954	0.941	0.950	0.954	0.950
150	0.954	0.958	0.941	0.958	0.958	0.950
200	0.954	0.958	0.950	0.958	0.962	0.954
250	0.954	0.958	0.950	0.958	0.962	0.958
300	0.954	0.958	0.954	0.958	0.962	0.958
350	0.954	0.958	0.954	0.958	0.962	0.958
400	0.958	0.958	0.958	0.958	0.962	0.958
450	0.962	0.962	0.958	0.958	0.962	0.958
500	0.962	0.962	0.958	0.958	0.962	0.958

*RHRS* = Annual operating hours of process fan. Actual hours should be used.

*%FF* = Percentage of run-time spent within a given flow fraction range.

Fans used in process applications operate under site-specific conditions. The percentage of run-time spent within each of the given ranges in the table below should be field collected.

Flow Fraction (% of design cfm)	Percent of Time at Flow Fraction
0% to 10%	Field Collected for each bin.
>10% to 20%	
>20% to 30%	
>30% to 40%	

<sup>1706</sup> Douglass, J. (2005). Induction Motor Efficiency Standards. Washington State University and the Northwest Energy Efficiency Alliance, Extension Energy Program, Olympia, WA, October 2005.

Flow Fraction (% of design cfm)	Percent of Time at Flow Fraction
>40% to 50%	
>50% to 60%	
>60% to 70%	
>70% to 80%	
>80% to 90%	
>90% to 100%	

$PLR_{Base}$  = Part load ratio for a given flow fraction range based on the baseline flow control type

$PLR_{Retrofit}$  = Part load ratio for a given flow fraction range based on the retrofit flow control type

Control Type	Flow Fraction									
	0-10%	>10% to 20%	>20% to 30%	>30% to 40%	>40% to 50%	>50% to 60%	>60% to 70%	>70% to 80%	>80% to 90%	>90% to 100%
No Control or Bypass Damper	1.00	1.00	1.00	1.00	1.00	1.00	1.00	1.00	1.00	1.00
Discharge Dampers	0.46	0.55	0.63	0.70	0.77	0.83	0.88	0.93	0.97	1.00
Outlet Damper, BI & Airfoil Fans	0.53	0.53	0.57	0.64	0.72	0.80	0.89	0.96	1.02	1.05
Inlet Damper Box	0.56	0.60	0.62	0.64	0.66	0.69	0.74	0.81	0.92	1.07
Inlet Guide Vane, BI & Airfoil Fans	0.53	0.56	0.57	0.59	0.60	0.62	0.67	0.74	0.85	1.00
Inlet Vane Dampers	0.38	0.40	0.42	0.44	0.48	0.53	0.60	0.70	0.83	0.99
Outlet Damper, FC Fans	0.22	0.26	0.30	0.37	0.45	0.54	0.65	0.77	0.91	1.06
Eddy Current Drives	0.17	0.20	0.25	0.32	0.41	0.51	0.63	0.76	0.90	1.04
Inlet Guide Vane, FC Fans	0.21	0.22	0.23	0.26	0.31	0.39	0.49	0.63	0.81	1.04
VFD with duct static pressure controls	0.09	0.10	0.11	0.15	0.20	0.29	0.41	0.57	0.76	1.01
VFD with low/no duct static pressure	0.05	0.06	0.09	0.12	0.18	0.27	0.39	0.55	0.75	1.00

$\sum_{0\%}^{100\%}(\%FF \times PLR)$  = The sum of the product of the percentage of run-time spent within a given flow fraction range (%FF) and the part load ratio for a given flow fraction range based on the retrofit flow control type.

Example: A process fan with discharge damper controls operates 85% of the time at 75% flow fraction, 5% of the time at 80% flow fraction, and 10% of the time at 95% flow fraction:

$$\begin{aligned} \sum_{0\%}^{100\%}(\%FF \times PLR) &= (0.85 \times 0.93) + (0.05 \times 0.97) + (0.10 \times 1.00) \\ &= 0.939\% \end{aligned}$$

**SUMMER COINCIDENT PEAK DEMAND SAVINGS**

$$kW_{Base} = \left( 0.746 \times HP \times \frac{LF}{\eta_{motor}} \right) \times PLR_{Base,FFpeak}$$

$$kW_{Retrofit} = \left( 0.746 \times HP \times \frac{LF}{\eta_{motor}} \right) \times PLR_{Retrofit,FFpeak}$$

$$\Delta kW_{fan} = kW_{Base} - kW_{Retrofit}$$

Where:

$kW_{Base}$	= Baseline summer coincident peak demand (kW)
$kW_{Retrofit}$	= Retrofit summer coincident peak demand (kW)
$\Delta kW_{fan}$	= Fan-only summer coincident peak demand impact
$\Delta kW_{total}$	= Total project summer coincident peak demand impact
$PLR_{Base,FFpeak}$	= The part load ratio for the average flow fraction between the peak daytime hours during the weekday peak time period based on the baseline flow control type (default average flow fraction during peak period = 90%)
$PLR_{Retrofit,FFpeak}$	= The part load ratio for the average flow fraction between the peak daytime hours during the weekday peak time period based on the retrofit flow control type (default average flow fraction during peak period = 90%)

#### **FOSSIL FUEL IMPACT DESCRIPTIONS AND CALCULATION**

There are no expected fossil fuel impacts for this measure.

#### **WATER IMPACT DESCRIPTIONS AND CALCULATION**

N/A

#### **DEEMED O&M COST ADJUSTMENT CALCULATION**

N/A

**MEASURE CODE: CI-MSC-VSDP-V03-240101**

**REVIEW DEADLINE: 1/1/2025**

## 4.8.14 Low Flow Toilets and Urinals

### DESCRIPTION

Toilets and urinals are found in bathrooms located in commercial, and industrial facilities. The first federal standards dealing with water consumption for toilets and urinals was the Energy Policy Act of 1992. It specified a gallon per flush (gpf) standard for both fixtures. These standards are used to define the baseline equipment for this measure. The Subsequent U.S. EPA WaterSense program in 2009 set even tighter standards for plumbing fixtures, including toilets and urinals. These standards are used to define the efficient equipment for this measure.

### DEFINITION OF EFFICIENT EQUIPMENT

The high efficiency equipment is either a U.S. EPA WaterSense certified commercial toilet fixture or commercial urinal.

### DEFINITION OF BASELINE EQUIPMENT

The baseline equipment is a toilet or urinal that has a maximum gallons per flush outlined by the Energy Policy Act of 1992.

### DEEMED LIFETIME OF EFFICIENT EQUIPMENT

The estimated useful life for this measure is assumed to be 25 years for both toilets and urinals.<sup>1707</sup>

### DEEMED MEASURE COST

The incremental costs for both toilets and urinals are \$0.<sup>1708</sup>

### LOADSHAPE

Loadshape CO2 - Commercial Electric DHW

### COINCIDENCE FACTOR

N/A

---

## Algorithm

---

### CALCULATION OF ENERGY SAVINGS

#### ELECTRIC ENERGY SAVINGS

The following savings should be included in the total savings for this measure but should not be included in TRC tests to avoid double counting the economic benefit of water savings.

$$\begin{aligned} \Delta \text{kWh} &= \Delta \text{Water} / 1,000,000 * E_{\text{water total}} \\ E_{\text{water}} &= \text{IL Total Water Energy Factor (kWh/Million Gallons)} \end{aligned}$$

---

<sup>1707</sup> ATD Home Inspection: <http://www.atdhomeinspection.com/advice/average-product-life/> is 50 years. 25 years is used to be conservative.

<sup>1708</sup> Measure cost assumption from City of Fort Collins, "Green Building Practice Summary," March 21, 2011, page 2. The document states "Information from the EPA WaterSense web site: WaterSense® labeled toilets are not more expensive than regular toilets. MaP testing results have shown no correlation between price and performance. Prices for toilets can range from less than \$100 to more than \$1,000. Much of the variability in price is due to style, not functional design."

$$= 5,010^{1709}$$

**Toilet Calculation:**

**For example**, a low flow toilet is installed in a commercial location.

$$\begin{aligned} \Delta kWh &= 491 \text{ gal/year} / 1,000,000 * 5,010 \text{ kWh/million gallons} \\ &= 2.5 \text{ kWh/year} \end{aligned}$$

**Urinal Calculation:**

**For example**, a low flow urinal is installed in a commercial location.

$$\begin{aligned} \Delta kWh &= 2,340 \text{ gal/year} / 1,000,000 * 5,010 \text{ kWh/million gallons} \\ &= 11.7 \text{ kWh/year} \end{aligned}$$

**SUMMER COINCIDENT PEAK DEMAND SAVINGS**

N/A

**FOSSIL FUEL SAVINGS**

N/A

**WATER IMPACT DESCRIPTIONS AND CALCULATION**

$$\Delta \text{Water} = (\text{GPF}_{\text{Base}} - \text{GPF}_{\text{Eff}}) * \text{NFPD} * \text{ADPY}$$

Where:

- GPF<sub>Base</sub> = Baseline equipment gallons per flush
  - = 1.6 for toilets<sup>1710</sup>
  - = 1.0 for urinals<sup>1711</sup>
- GPF<sub>Eff</sub> = Efficient equipment gallons per flush
  - = Actual, if unknown assume 1.28 for toilets<sup>1712</sup>
  - = Actual, if unknown assume 0.5 for urinals<sup>1713</sup>
- NFPD = Number of flushes per day
  - = 5.9 for toilets<sup>1714</sup>
  - = 18 for urinals<sup>1715,1716</sup>
- ADPY = Annual days per year
  - = 260 for commercial and industrial<sup>1717</sup>

<sup>1709</sup> This factor includes 2571 kWh/MG for water supply based on Illinois energy intensity data from a 2012 ISAWWA study and 2439 kWh/MG for wastewater treatment based on national energy intensity use estimates. For more information, please review Elevate Energy’s Review ‘IL TRM: Energy per Gallon Factor, May 2018’.

<sup>1710</sup> U. S. EPA WaterSense. “Water Efficiency Management Guide – Bathroom Suite” (EPA 832-F-17-016d), Nov 2017.

<sup>1711</sup> U.S. EPA WaterSense. “WaterSenses Specification for Flushing Urinals Supporting Statement”, Oct 2009.

<sup>1712</sup> U. S. EPA WaterSense. “Water Efficiency Management Guide – Bathroom Suite” (EPA 832-F-17-016d), Nov 2017.

<sup>1713</sup> U.S. EPA WaterSense. “WaterSenses Specification for Flushing Urinals Supporting Statement”, Oct 2009.

<sup>1714</sup> CASE Initiative for PY 2013: Analysis of Standards Proposal for Toilets and Urinals Water Efficiency. July 29, 2013. Pg 18.

<sup>1715</sup> Ibid.

<sup>1716</sup> U.S. EPA WaterSense. “WaterSenses Specification for Flushing Urinals Supporting Statement”, Oct 2009. Pg 1.

<sup>1717</sup> Assuming the work week is Monday through Friday.

**Toilet Calculation:**

**For example**, a low flow toilet is installed in a commercial location.

$$\begin{aligned}\Delta\text{Water} &= [(1.6 - 1.28) \text{ gal/flush} \times 5.9 \text{ flush/day} \times 260 \text{ days/year}] \\ &= 491 \text{ gal/year}\end{aligned}$$

**Urinal Calculation:**

**For example**, a low flow urinal is installed in a commercial location.

$$\begin{aligned}\Delta\text{Water} &= (1.0 - 0.5) \text{ gal/flush} \times 18 \text{ flush/day} \times 260 \text{ days/year} \\ &= 2,340 \text{ gal/year}\end{aligned}$$

**DEEMED O&M COST ADJUSTMENT CALCULATION**

N/A

**MEASURE CODE: CI-MSC-LFTU-V02-210101**

**REVIEW DEADLINE: 1/1/2023**

## 4.8.15 Smart Irrigation Controls

### DESCRIPTION

Irrigation systems are commonly found on commercial properties, educational institutions, public parks, golf courses, and other facilities with landscaped grounds. They are typically operated on timers, applying the irrigation water in the early morning or after dusk. The timing and duration of irrigation application are determined by the user, along with the location and density of sprinklers. The irrigation water gets applied according to the control schedule, regardless of whether the landscape actually needs the irrigation water at that time.

The new measure involves the installation of a control system technology that reduces or eliminates irrigation during times of precipitation or when there is already sufficient soil moisture. This measure applies to landscape irrigation systems for commercial, institutional, and public properties only. It does not apply to agricultural irrigation systems for crops or residential landscape irrigation systems.

This measure was developed to be applicable to the following program types: TOS, RF. If applied to other program types, the measure savings should be verified.

### DEFINITION OF EFFICIENT EQUIPMENT

Smart Irrigation Controls utilize sensors, gauges, or local weather forecasts to regulate the application of irrigation water to lawn or landscape vegetation. There are two main technologies used for this purpose: 1) Precipitation based smart irrigation controllers, and 2) Soil-moisture based smart irrigation controllers.

#### Precipitation Based Smart Irrigation Controllers

This type of system utilizes either an on-site rain gauge or a local weather service to determine if there is sufficient precipitation to allow shut-off of the irrigation water.

#### Soil Moisture Based Smart Irrigation Controllers

This type of system utilizes soil moisture sensors, buried in the root zone, to determine if irrigation water is needed. A “suspended cycle irrigation system” uses the soil moisture sensors to determine whether a regularly scheduled irrigation application is necessary. If there is sufficient soil moisture, then the next scheduled irrigation cycle gets interrupted. A “water-on-demand irrigation system” applies irrigation water when the moisture sensor reaches its lower limit and shuts off when the moisture sensor reaches its upper limit. There is no regularly scheduled irrigation with the water on demand system.

For the purposes of this measure characterization, the assumed rolling 24-hour threshold for shutting off the irrigation is 6 mm (0.24”). The Savings Factor is based on the percentage of time that the rolling 24-hour average of precipitation meets or exceeds the 6 mm threshold.

### DEFINITION OF BASELINE EQUIPMENT

The baseline irrigation system applies irrigation water to the lawn or landscape on a regularly scheduled timer. The timing and duration of irrigation application are determined by the user, along with the location and density of sprinklers. The irrigation water gets applied according to the control schedule, regardless of whether the landscape actually needs the irrigation water at that time.

Sprinkler head nozzles have a variety of configurations that affect the distribution of the irrigation water. The water can come in the form of a spray, a rotating plume, a bubbler, or a drip.

Typical baseline irrigation systems provide 1 inch of irrigation to the entire lawn. This is equivalent to 0.623 gallons per square foot of lawn per week.<sup>1718</sup>

---

<sup>1718</sup> Today’s Homeowner with Danny Lipford. “How to Calculate Lawn Irrigation Water Usage and Costs.”

**DEEMED LIFETIME OF EFFICIENT EQUIPMENT**

The expected useful life for Irrigation Control Measures is assumed to be 15 years.

**DEEMED MEASURE COST**

The measure cost for a multi-zone smart irrigation control system is \$500.<sup>1719</sup>

**LOADSHAPE**

N/A

**COINCIDENCE FACTOR**

N/A

**Algorithm**

**CALCULATION OF ENERGY SAVINGS**

Energy savings from Irrigation Control Measures are the result of reduced water consumption. There are indirect electric energy savings from reduced potable water treatment.

**ELECTRIC ENERGY SAVINGS**

The electric energy savings are based indirectly on the reduced electricity usage used to provide the potable water and treat the wastewater. By applying an “Energy Factor”, the water savings (in gallons/year) can be converted to electricity savings (in kWh/year). This “Energy Factor” considers the electric energy requirements of potable water treatment plants and potable water distribution. Since the “wasted” irrigation water in the baseline case will likely be absorbed into the soil or will runoff into surface water bodies, electricity savings from a reduction in wastewater treatment load would not apply.

The methodology for quantifying the water savings involves a direct comparison of the baseline equipment to the efficient equipment. In order to calculate the baseline water usage of an irrigation system, the number of sprinklers and their sizing need to be determined. The static pressure and sizing of the water service, along with the sprinkler head orifice sizing will ultimately determine the flow rate of water.

The electricity savings for this measure can be calculated by applying an energy factor to the calculated water savings.

$$\Delta kWh_{water} = \Delta Water / 1,000,000 * E_{water}$$

Where:

$$E_{water} = \text{Illinois Total Water Energy Factor (kWh/Million Gallons)} \\ = 2,571^{1720}$$

The total water savings for this measure can be calculated as follows:

$$\Delta Water = BSFL - ESFL$$

Where:

<sup>1719</sup> Material pricing taken from Google shopping search on “smart irrigation control system”. The Rain Bird Smart LNK WiFi Irrigation System Indoor Controller (4 Pack) sells for \$316 from online retailer Wish.com. Installation labor pricing taken from online retailer Home Advisor – Lawn and Garden, Repair a Sprinkler System **Error! Hyperlink reference not valid.** which stated \$45 to \$200 per hour for a plumber.

<sup>1720</sup> This factor include 2571 kWh/MG for water supply based on Illinois energy intensity data from a 2012 ISAWWA study and 2439 kWh/MG for wastewater treatment based on national energy intensity use estimates. For more information please review Elevate Energy’s ‘IL TRM: Energy per Gallon Factor, May 2018 paper’.



$$\Delta\text{Water} = \text{Total Water Savings (gallon/season)}$$

The baseline volumetric flow rate for the entire system can be calculated as follows:

$$\text{BSFL} = \text{NOS} \times \text{SFL} \times \text{DOI} \times \text{NAY}$$

Where:

BSFL	= Baseline System Flow Rate (gallon/year)
NOS	= Number of Sprinklers, the total number of sprinklers at the property = Actual
SFL	= Sprinkler Flow Rate (gallon/minute) = Actual, site-specific irrigation system specifications should be consulted to determine the property's sprinkler flow rate
DOI	= Duration of Irrigation (minutes/application) = Actual, the baseline scheduling controls should be used to determine the irrigation season
NAY	= Number of Applications per Year (application/year) = Actual

The efficient volumetric flow rate can be calculated as follows:

$$\text{ESFL} = \text{BSFL} \times (1 - \text{SF})$$

Where:

ESFL	= Efficient System Flow Rate (gallon/season)
BSFL	= Baseline System Flow Rate (gallon/season)
SF	= Savings Factor

The volumetric flow rate for the entire efficient system is based on applying a Savings Factor (SF) to the BSFL. The SF is determined by calculating the number of weeks in the irrigation season (April 25 through October 13) when there is sufficient precipitation to allow the shutoff of the irrigation system. Typical Meteorological Year (TMY-3) data gives precipitation depth in millimeters for each hour of the typical year. By consulting the TMY-3 data for the closest applicable weather station, the SF can be determined.

One source recommends a rain sensor shut-off threshold of 6 mm of precipitation for twice or thrice weekly irrigation schedule or 13 mm of precipitation for once weekly irrigation schedule.<sup>1721</sup> For the purposes of this workpaper, we will use a rolling 24-hour threshold of 6 mm.

The State Climatologist Office for Illinois produced a map of the Illinois Growing Season days per year for different parts of the state.<sup>1722</sup> Using a growing season average of 170 days, the “irrigation season” begins on April 25 and end on October 13.

By analyzing the TMY-3 precipitation data, the number of weeks during the “irrigation season” that the rolling 24-hour precipitation levels greater than 6 mm can be determined, along with the Savings Factors:

Chicago:	SF = 0.265
Midway:	SF = 0.241
Rockford:	SF = 0.268
Peoria:	SF = 0.227
Springfield:	SF = 0.186

---

<sup>1721</sup> Michael D. Dukes. “Smart Irrigation Controllers: What Makes an Irrigation Controller Smart”. University of Florida, Institute for Food & Agricultural Sciences.

<sup>1722</sup> State Climatologist Office for Illinois, Illinois State Water Survey, 2003. Based on 1971 – 2000 data, assessing the number of days between the last spring drop below 32 degrees and the first fall drop below 32 degrees.

**SUMMER COINCIDENT PEAK DEMAND SAVINGS**

N/A

**FOSSIL FUEL SAVINGS**

N/A

**WATER AND OTHER NON-ENERGY IMPACT DESCRIPTIONS AND CALCULATION**

The water savings inherent in the efficient irrigation control technology will help preserve water supplies and extend the life of water treatment and wastewater treatment equipment. By reducing irrigation during periods of precipitation, unnecessary storm runoff and puddling can be avoided. For more details on calculating water savings, please see the 'Algorithm' section of this characterization.

**DEEMED O&M COST ADJUSTMENT CALCULATION**

Maintaining an Efficient Irrigation Control system will require periodic cleaning and calibration of the sensors. Any wiring or wireless communication devices will also need to be maintained. Costs for these activities is \$196.<sup>1723</sup>

**MEASURE CODE: CI-MSC-SIRC-V02-220101**

**REVIEW DEADLINE: 1/1/2025**

---

<sup>1723</sup> Based on data provided on Home Advisor website, Lawn and Garden, Repair a Sprinkler System.**Error! Hyperlink reference not valid.**

## 4.8.16 Commercial Weather Stripping

### DESCRIPTION

Note- this measure provides a prescriptive approach for commercial door sweeps. A more comprehensive approach that requires a number of additional inputs for both this and a number of other commercial air sealing opportunities is provided in measure 4.8.27 C&I Air Sealing.

Entrance/exit doors installed for a commercial or industrial buildings often leave clearance gaps to allow for proper operation. The gaps around the doors allow unconditioned air to infiltrate the building due to wind force, internal building stack affect, and other temperature differentials, thus adding to the cooling and heating loads of an HVAC system. Sweeps and other weatherstripping applications are designed to close these gaps, while still allowing proper operation. They are installed along the bottom, head, and jambs of exterior doors to prevent air infiltration from adding to the HVAC load.

This measure was developed to be applicable to the following program types: RF, DI. If applied to other program types, the measure savings should be verified.

### DEFINITION OF EFFICIENT EQUIPMENT

There are a variety of types of materials used as door sweeps and weather stripping, including nylon bristles, felt, vinyl, open or closed-cell foam, and EPDM rubber. Their effectiveness is assumed to be the same when properly installed.

### DEFINITION OF BASELINE EQUIPMENT

This measure shall apply to the exterior doors on commercial buildings that are not sealed from the outside environment (i.e., interior vestibule doors would be ineligible) with visible gaps of at least 1/8 inches and up to 3/4 inches along any outside edge of the door. The space on the interior of the door must be conditioned and/or heated, and the calculation methodology will use standard efficiencies of 1.0 kW/ton for cooling and 80% for heating. Electric resistance heating and electric heat pump systems will use coefficients of performance (COPs) of 1.0 and 3.3, respectively.

### DEEMED LIFETIME OF EFFICIENT EQUIPMENT

The estimated useful life (EUL) is 10 years.<sup>1724</sup>

### DEEMED MEASURE COST

Costs for this measure should be determined by actual quotes obtained from manufacturers and estimated labor. If not available, it is estimated based on brush weather strips cost of \$5.50/LF with labor and other direct costs of installation costing \$2.50/LF with the total coming to \$8.00/LF.<sup>1725</sup>

### LOADSHAPE

Loadshape C03 - Commercial Cooling

Loadshape C04 - Commercial Electric Heating

Loadshape C05 - Commercial Electric Heating and Cooling

### COINCIDENCE FACTOR

$CF_{SSP}$  = Summer System Peak Coincidence Factor for Commercial cooling (during system peak hour)

---

<sup>1724</sup> Assumed lower than residential due to likely significantly higher door usage.

<sup>1725</sup> Deemed costs referenced from the Arkansas TRM.

$$= 91.3\%^{1726}$$

$CF_{PJM}$  = PJM Summer Peak Coincidence Factor for Commercial cooling (average during peak period)

$$= 47.8\%^{1727}$$

---



---

**Algorithm**

---



---

**CALCULATION OF ENERGY SAVINGS**

**ELECTRIC ENERGY SAVINGS**

$$\Delta kWh = (\Delta kWh_{Cool_{weatherstrip}} + \Delta kWh_{Heat_{weatherstrip}}) * Length$$

Where:

$\Delta kWh_{Cool_{weatherstrip}}$  = Annual cooling kWh savings from installation of door sweep per linear foot<sup>1728</sup>

Climate Zone (City based upon)	$\Delta kWh_{Cool_{weatherstrip}}$ per linear ft
1 (Rockford)	0.33
2 (Chicago)	0.36
3 (Springfield)	0.63
4 (Belleville)	0.59
5 (Marion)	0.70

$\Delta kWh_{Heat_{weatherstrip}}$  = Annual heating kWh savings from installation of door sweep per linear foot<sup>1729</sup>

Climate Zone (City based upon)	$\Delta kWh_{weatherstrip}$ per linear ft	
	Electric Resistance	Heat Pump
1 (Rockford)	89.4	44.7
2 (Chicago)	78.6	39.3
3 (Springfield)	69.2	34.6
4 (Belleville)	59.9	29.9
5 (Marion)	48.0	24.0

Length = Linear feet of door weatherstripping installed

<sup>1726</sup> Based on analysis of Itron eShape data for Missouri, calibrated to Illinois loads, supplied by Ameren. The AC load during the utility's peak hour is divided by the maximum AC load during the year.

<sup>1727</sup> Based on analysis of Itron eShape data for Missouri, calibrated to Illinois loads, supplied by Ameren. The average AC load over the PJM peak period (1-5pm, M-F, June through August) is divided by the maximum AC load during the year.

<sup>1728</sup> Savings are based on lab test results performed by CLEAResult, assuming an 1/8" gap. See 'Commercial Weather Stripping IL\_TRM\_Workpaper v1.2'. Following discussion with the TAC it was determined that due to concerns over engineering algorithms overclaiming savings, 50% of the savings for the 1/8" gap are deemed appropriate.

<sup>1729</sup> Converts the Therm value to kWh and incorporates the relative COP efficiencies (assumed 0.78 for gas heat, 1 for electric resistance and 2.0 for heat pumps).

**SUMMER COINCIDENT PEAK DEMAND SAVINGS**

$$\Delta kW = (\Delta kWh_{Cool_{weatherstrip}} * Length) / EFLH_{cooling} * CF$$

Where:

- EFLH<sub>cooling</sub> = Equivalent full load hours of air conditioning in Existing Buildings or New Construction are provided in Section 4.4, HVAC end use
- CF<sub>SSP</sub> = Summer System Peak Coincidence Factor for Commercial cooling (during system peak hour)  
= 91.3%<sup>1730</sup>
- CF<sub>PJM</sub> = PJM Summer Peak Coincidence Factor for Commercial cooling (average during peak period)  
= 47.8%<sup>1731</sup>

**FOSSIL FUEL SAVINGS**

$$\Delta Therms = \Delta Therms_{weatherstrip} * Length$$

Where:

$\Delta Therms_{weatherstrip}$  = Annual therm savings from installation of door sweep per linear foot<sup>1732</sup>

Climate Zone (City based upon)	$\Delta Therms_{weatherstrip}$ per linear ft
1 (Rockford)	3.91
2 (Chicago)	3.44
3 (Springfield)	3.03
4 (Belleville)	2.62
5 (Marion)	2.1

Length = Linear feet of door weatherstripping installed

**WATER AND OTHER NON-ENERGY IMPACT DESCRIPTIONS AND CALCULATION**

NA

**DEEMED O&M COST ADJUSTMENT CALCULATION**

NA

**MEASURE CODE: CI-MSC-WTST-V02-230101**

**REVIEW DEADLINE: 1/1/2027**

<sup>1730</sup> Based on analysis of Itron eShape data for Missouri, calibrated to Illinois loads, supplied by Ameren. The AC load during the utility’s peak hour is divided by the maximum AC load during the year.  
<sup>1731</sup> Based on analysis of Itron eShape data for Missouri, calibrated to Illinois loads, supplied by Ameren. The average AC load over the PJM peak period (1-5pm, M-F, June through August) is divided by the maximum AC load during the year.  
<sup>1732</sup> Savings are based on lab test results performed by CLEAResult, assuming an 1/8” gap. See ‘Commercial Weather Stripping IL\_TRM\_Workpaper v1.2’. Following discussion with the TAC it was determined that due to concerns over engineering algorithms overclaiming savings, 50% of the savings for 1/8” gap are deemed appropriate. This provides a savings assumption that is similar to the prescriptive Residential door sweep measure in 5.6.1 Air Sealing (assuming 3 ft doorsweep).

## 4.8.17 Switch Peripheral Equipment Consolidation

### **DESCRIPTION**

This measure will allow for projects with small scopes of equipment replacement to be cost effectively brought into the telecommunication optimization incentive program. Consolidating telecommunication line and trunk equipment eliminate underutilized equipment which reduces power draw from the rectifier. This avoided heat load also results in cooling savings.

This measure was developed to be applicable to the following program types: RF. If applied to other program types, the measure savings should be verified.

### **DEFINITION OF EFFICIENT EQUIPMENT**

The measure requires no new equipment and only consolidates partially loaded equipment. There are a myriad of different types of line and trunk equipment, but consolidation eliminates underutilized equipment which will result in energy savings.

### **DEFINITION OF BASELINE EQUIPMENT**

Baseline telecommunications equipment is partially loaded line and trunk equipment that is no longer needed due to line loss on the telecommunications network. Lines are consolidated to like equipment and the underutilized equipment is removed. This applies to all line and trunk equipment and does not exclude participation from any particular type of line and trunk equipment. All line and trunk equipment are considered eligible but only up to and including 40 pieces of equipment. Above that amount, projects will require on-site amp reduction verification.

Baseline cooling equipment is assumed to be an Air-Cooled Chiller without an economizer with a capacity >240 MBtu. If cooling equipment can be verified, the chiller efficiency can be replaced with the appropriate value using Table below.

**ASHRAE 90.1 2016: Table 6.8.1-11**

Equipment Type	Net Sensible Cooling Capacity	Downflow units	Upflow - Ducted	Upflow - Unducted	Horizontal Flow
		COP	COP	COP	COP
Air Cooled	< 65 MBtuh	2.30	2.10	2.09	2.45
	> 65 MBtuh and < 240 MBtuh	2.20	2.05	1.99	2.35
	> 240 MBtuh	2.00	1.85	1.79	2.15
Water Cooled	< 65 MBtuh	2.50	2.30	2.25	2.70
	> 65 MBtuh and < 240 MBtuh	2.40	2.20	2.15	2.60
	> 240 MBtuh	2.25	2.10	2.05	2.45
Water Cooled with Fluid Economizer	< 65 MBtuh	2.45	2.25	2.20	2.60
	> 65 MBtuh and < 240 MBtuh	2.35	2.15	2.10	2.55
	> 240 MBtuh	2.20	2.05	2.00	2.40
Glycol Cooled	< 65 MBtuh	2.30	2.10	2.00	2.40
	> 65 MBtuh and < 240 MBtuh	2.05	1.85	1.85	2.15
	> 240 MBtuh	1.95	1.80	1.75	2.10
Glycol Cooled with Fluid Economizer	< 65 MBtuh	2.25	2.10	2.00	2.35
	> 65 MBtuh and < 240 MBtuh	1.95	1.80	1.75	2.10
	> 240 MBtuh	1.90	1.80	1.70	2.10

**Converted ASHRAE 90.1 2016: Table 6.8.1-11 Cooling Efficiency Table**

Equipment Type	Net Sensible Cooling Capacity	Downflow units	Upflow - Ducted	Upflow - Unducted	Horizontal Flow
		kW/Ton	kW/Ton	kW/Ton	kW/Ton
Air Cooled	< 65 MBtuh	1.53	1.67	1.68	1.44
	> 65 MBtuh and < 240 MBtuh	1.60	1.72	1.77	1.50
	> 240 MBtuh	1.76	1.90*	1.96	1.64
Water Cooled	< 65 MBtuh	1.41	1.53	1.56	1.30
	> 65 MBtuh and < 240 MBtuh	1.47	1.60	1.64	1.35
	> 240 MBtuh	1.56	1.67	1.72	1.44
Water Cooled with Fluid Economizer	< 65 MBtuh	1.44	1.56	1.60	1.35
	> 65 MBtuh and < 240 MBtuh	1.50	1.64	1.67	1.38
	> 240 MBtuh	1.60	1.72	1.76	1.47
Glycol Cooled	< 65 MBtuh	1.53	1.67	1.76	1.47
	> 65 MBtuh and < 240 MBtuh	1.72	1.90	1.90	1.64
	> 240 MBtuh	1.80	1.95	2.01	1.67
Glycol Cooled with Fluid Economizer	< 65 MBtuh	1.56	1.67	1.76	1.50
	> 65 MBtuh and < 240 MBtuh	1.80	1.95	2.01	1.67
	> 240 MBtuh	1.85	1.95	2.07	1.67

\*Default value based on previous program data; in all but one project, this was the cooling efficiency value used

**DEEMED LIFETIME OF EFFICIENT EQUIPMENT**

10 years.<sup>1733</sup>

**DEEMED MEASURE COST**

There is no equipment cost to implement this measure. The only associated cost is the required internal labor to move lines from the to-be-removed piece of equipment to the chosen like piece of equipment. The default labor cost is \$742/piece of equipment removed.<sup>1734</sup>

**LOADSHAPE**

Loadshape is determined by the constant power draw by the line and trunk equipment; default loadshape is: Loadshape C53 – Flat.

**COINCIDENCE FACTOR**

Coincidence Factor is determined by the constant power draw by the line and trunk equipment; the summer peak coincidence factor for the line and trunk equipment is assumed to be 100%. The cooling coincident factor is assumed to be consistent with the summer system peak coincidence factor as provided below:

$$CF_{SSP} = \text{Summer System Peak Coincidence Factor for Commercial cooling (during system peak hour)}$$

$$= 91.3\% \text{ }^{1735}$$

---



---

**Algorithm**

---



---

**CALCULATION OF ENERGY SAVINGS**

**ELECTRIC ENERGY SAVINGS**

$$\text{kWh Savings} = p * kW_{\text{Trunk}} * (1 + LCF * CE) * t$$

Where:

- p = Number of pieces of redundant equipment removed  
= Actual
- kW<sub>Trunk</sub> = Average line and trunk equipment power draw  
= 0.233 kW<sup>1736</sup>
- LCF = Load Conversion Factor kW to Ton of cooling (tons/kW)  
= 0.284<sup>1737</sup>

---

<sup>1733</sup> Assumption is based on communication from AT&T program manager indicating an expectation that consolidated equipment should be expected to remain for a minimum of 10 years.

<sup>1734</sup> Value based on the average of program data provided by Franklin Energy. See “Network Combing Workpaper Research\_v2.xls” for details. Note projects were capped at 40 pieces of equipment in the development of this average.

<sup>1735</sup> Based on analysis of Itron eShape data for Missouri, calibrated to Illinois loads, supplied by Ameren. The AC load during the utility’s peak hour is divided by the maximum AC load during the year.

<sup>1736</sup> Value based on the average of program data provided by Franklin Energy. See “Network Combing Workpaper Research\_v2.xls” for details. Note projects were capped at 40 pieces of equipment in the development of this average.

<sup>1737</sup> 1 ton of cooling = 12,000 BTU/h. 1kWh = 3412 BTU. Therefore 1 ton of cooling = 12000BTU/h \* 1 kWh/3412 BTU = 3.51 kW per ton, = 0.284 tons/kW.



CE = Cooling Efficiency  
 = Actual, if unknown assume 1.90 kW/ton<sup>1738</sup>

t = time (hours)  
 = 8,760 hours

**SUMMER COINCIDENT PEAK DEMAND SAVINGS**

$$\text{kW Savings} = p * \text{kW}_{\text{Trunk}} * (\text{CF}_{\text{Trunk}} + \text{LCF} * \text{CE} * \text{CF}_{\text{SSPCool}})$$

Where:

p = Number of pieces of redundant equipment removed

$\text{kW}_{\text{Trunk}}$  = Average line and trunk equipment power draw, 0.233 kW

LCF = Load Conversion Factor kW to Ton, 0.284

CE = Cooling Efficiency, default value = 1.90 kW/ton based on previous program data

$\text{CF}_{\text{Trunk}}$  = Line and Trunk Equipment Coincidence Factor, 1.0

$\text{CF}_{\text{SSPCool}}$  = Summer System Peak Coincidence Factor for Commercial cooling (during system peak hour)  
 = 91.3%<sup>1739</sup>

**FOSSIL FUEL SAVINGS**

N/A

**WATER AND OTHER NON-ENERGY IMPACT DESCRIPTIONS AND CALCULATION**

N/A

**DEEMED O&M COST ADJUSTMENT CALCULATION**

N/A

**MEASURE CODE: CI-MSC-SPEC-V02-230101**

**REVIEW DEADLINE: 1/1/2027**

---

<sup>1738</sup> Cooling efficiency kW/ton default is based on air cooled units >240 Mbtuh, upflow ducted value as per the ASHRAE 90.1 2016 tables provided in the baseline section. This was the appropriate cooling efficiency value for all but one of Franklin Energy's projects.

<sup>1739</sup> Based on analysis of Itron eShape data for Missouri, calibrated to Illinois loads, supplied by Ameren. The AC load during the utility's peak hour is divided by the maximum AC load during the year.

## 4.8.18 ENERGY STAR Uninterruptible Power Supply

### DESCRIPTION

This measure is for replacing an inefficient uninterruptible power supply (UPS) with an efficient ENERGY STAR rated UPS in telecommunications, or similar facility that operates continuously. Note for data centers and other facilities that are not operated similarly to telecommunication applications, a custom calculation based on M&V analysis and that accounts for ramp-up of loads on the UPS should be performed. UPS units provide backup power in data centers and draw power constantly to keep their batteries charged. Uninterruptible power supplies (UPS) are utilized in many organizations to protect themselves from downtime with power distribution and avoid data processing errors due to downtimes. UPS systems are connected between the public power distribution system and mission critical loads.

This measure was developed to be applicable to the following program types: TOS. If applied to other program types, the measure savings should be verified.

### DEFINITION OF EFFICIENT EQUIPMENT

The efficient condition is a new ENERGY STAR UPS in a telecommunication or similar application. For single-normal mode UPSs, the installed system must meet or exceed the average loading-adjusted efficiency values required by the ENERGY STAR program.

### DEFINITION OF BASELINE EQUIPMENT

The baseline condition is an existing non-ENERGY STAR UPS in a telecommunication or similar application.

### DEEMED LIFETIME OF EFFICIENT EQUIPMENT

The measure life is assumed to be 15 years.<sup>1740</sup>

### DEEMED MEASURE COST

The incremental cost is estimated at \$59 per UPS unit.<sup>1741</sup>

### LOADSHAPE

Loadshape is determined by the constant power draw by the UPS; default loadshape is Loadshape C53 – Flat.

### COINCIDENCE FACTOR

The coincidence factor for the UPS or rectifier is assumed to be 1.0 due to equipment operating during peak period.

---

<sup>1740</sup> California Municipal Utilities Association. Savings Estimation Technical Reference Manual 2017, Third Edition. Section 8.12, p. 8–15.

<sup>1741</sup> As estimated in the California Municipal Utilities Association. Savings Estimation Technical Reference Manual 2017, incremental measure cost based on average UPS costs for a range of sizes, assuming a 30% premium for an ENERGY STAR UPS.

**Algorithm**

**CALCULATION OF ENERGY SAVINGS**

**ELECTRIC ENERGY SAVINGS**

$$\Delta \text{kWh} = \text{Size} * (1/\text{Eff}_{\text{AVGbase}} - 1/\text{Eff}_{\text{AVGee}}) * \text{EFLH}$$

Where:

Size = Size of UPS in rated output power, kW

Eff<sub>AVGbase</sub> = Efficiency of existing UPS  
 = Actual or use table below<sup>1742</sup>

UPS Product Class	Rated Output Power	Minimum Efficiency
Voltage and Frequency Dependent (VFD)	P ≤ 300 W	$-1.20 \times 10^{-6} \times P^2 + 7.17 \times 10^{-4} \times P + 0.862$
	300 W < P ≤ 700 W	$-7.85 \times 10^{-8} \times P^2 + 1.01 \times 10^{-4} \times P + 0.946$
	P > 700 W	$-7.23 \times 10^{-9} \times P^2 + 7.52 \times 10^{-6} \times P + 0.977$
Voltage Independent (VI)	P ≤ 300 W	$-1.20 \times 10^{-8} \times P^2 + 7.19 \times 10^{-4} \times P + 0.863$
	300 W < P ≤ 700 W	$-7.67 \times 10^{-8} \times P^2 + 1.05 \times 10^{-4} \times P + 0.946$
	P > 700 W	$-4.62 \times 10^{-9} \times P^2 + 8.54 \times 10^{-6} \times P + 0.979$
Voltage and Frequency Independent (VFI)	P ≤ 300 W	$-3.13 \times 10^{-8} \times P^2 + 1.960 \times 10^{-4} \times P + 0.543$
	300 W < P ≤ 700 W	$-2.60 \times 10^{-8} \times P^2 + 3.65 \times 10^{-4} \times P + 0.764$
	P > 700 W	$-1.70 \times 10^{-8} \times P^2 + 3.85 \times 10^{-6} \times P + 0.876$

Eff<sub>AVGee</sub> = Efficiency of new ENERGY STAR UPS  
 = Actual or ENERGY STAR minimum value from table below<sup>1743</sup>

Rated Output Power	UPS Product Class		
	VFD	VI	VFI
P ≤ 350 W	$5.71 \times 10^{-5} \times P + 0.962$	$5.71 \times 10^{-5} \times P + 0.964$	$0.011 \times \ln(P) + 0.824$
350 W < P ≤ 1.5 kW	0.982	0.984	$0.011 \times \ln(P) + 0.824$
1.5 kW < P ≤ 10 kW	0.981 - E <sub>MOD</sub>	0.981 - E <sub>MOD</sub>	$0.0145 \times \ln(P) + 0.8 - E_{\text{MOD}}$
P > 10 kW	0.97	0.94	$0.0058 \times \ln(P) + 0.886$

E<sub>MOD</sub> = an allowance of 0.004 for Modular UPSs applicable in the commercial 1500 – 10,000 W range

EFLH = Equivalent Full Load Hours, per equation below and values provided in table<sup>1744</sup>  
 $= (t_{0.25} \times 0.25 + t_{0.5} \times 0.5 + t_{0.75} \times 0.75 + t_{1.0} \times 1.0) \times 8760 \text{ hours}$

Rated Output Power (P) in watts	UPS Product Class	Time spent at specified proportion of reference test load (t)				EFLH
		25%	50%	75%	100%	
P ≤ 1.5 kW	VFD	0.2	0.2	0.3	0.3	5913

<sup>1742</sup> Code of Federal Regulations, Energy Conservation Standards for Uninterruptible Power Supplies, effective January 10, 2022 (10 CFR 430.32(z)(3).

<sup>1743</sup> ENERGY STAR Uninterruptible Power Supplies Final Version 2.0 Specification, effective January 1, 2019.

<sup>1744</sup> Calculation and inputs provided in ENERGY STAR Uninterruptible Power Supplies Final Version 2.0 Specification.

Rated Output Power (P) in watts	UPS Product Class	Time spent at specified proportion of reference test load (t)				EFLH
		25%	50%	75%	100%	
	VI or VFI	0	0.3	0.4	0.3	6570
1.5 kW < P ≤ 10 kW	VFD, VI, or VFI	0	0.3	0.4	0.3	6570
P > 10 kW	VFD, VI, or VFI	0.25	0.5	0.25	0	4380

Default Energy Savings are provided below:<sup>1745</sup>

Output Power Range	Single-Normal Mode UPS Systems			Multiple-Normal Mode UPS Systems	
	VFD	VI	VFI	VFD <sub>25%</sub> /VI <sub>75%</sub>	VFD <sub>25%</sub> /VFI <sub>75%</sub>
P ≤ 350 W	509.3	574.0	1,020.3	572.0	837.7
350 W < P ≤ 1.5 kW	162.5	246.2	-407.4*	229.7	-219.0*
1.5 kW < P ≤ 10 kW	131.7	105.8	-609.2*	115.9	-383.8*
10 kW < P < 16 kW	65.2	-63.4*	255.1	-21.9*	210.9
16 kW ≤ P ≤ 80 kW	65.2	31.4	62.6	48.6	72.3
P > 80 kW	65.2	31.4	102.7	48.6	72.3

\*' negative savings, i.e. an increase in consumption and so these are not recommended

**SUMMER COINCIDENT PEAK DEMAND SAVINGS**

$$\Delta kW = \text{Size} * (1/\text{Eff}_{\text{AVGbase}} - 1/\text{Eff}_{\text{AVGee}}) * \text{CF}$$

Where:

$$\text{CF}_{\text{IT}} = \text{Coincidence factor of UPS} = 1.0$$

Default Summer Peak Demand Savings are provided below based on defaults above:

Output Power Range	Single-Normal Mode UPS Systems			Multiple-Normal Mode UPS Systems	
	VFD	VI	VFI	VFD <sub>25%</sub> /VI <sub>75%</sub>	VFD <sub>25%</sub> /VFI <sub>75%</sub>
P ≤ 350 W	0.0861	0.0874	0.1553	0.0871	0.1275
350 W < P ≤ 1.5 kW	0.0275	0.0375	-0.0620*	0.0350	-0.0333*
1.5 kW < P ≤ 10 kW	0.0223	0.0161	-0.0927*	0.01764	-0.05842*
10 kW < P < 16 kW	0.0149	-0.0096*	0.0388	-0.00333*	0.03210
16 kW ≤ P ≤ 80 kW	0.0149	0.0048	0.0095	0.00740	0.01101
P > 80 kW	0.0149	0.0048	0.0156	0.00740	0.01101

**NATURAL GAS SAVINGS**

N/A

**DEEMED O&M COST ADJUSTMENT CALCULATION**

N/A

<sup>1745</sup> Default savings are provided in a calculation file provided by Franklin Energy that averages a number of power ratings within each range. See “ENERGY STAR UPS Calculations\_2022-05-15.xls” for more information.

**MEASURE CODE: CI-MSC-UPSE-V03-230101**

**REVIEW DEADLINE: 1/1/2026**

## 4.8.19 Energy Efficient Rectifier

### DESCRIPTION

This measure is for replacing an inefficient rectifier with an efficient unit in a data center, telecommunications, or similar facility that operates continuously. A rectifier converts alternating current (AC) to direct current (DC).

This measure was developed to be applicable to the following program types: TOS. If applied to other program types, the measure savings should be verified.

### DEFINITION OF EFFICIENT EQUIPMENT

The efficient condition is a new rectifier whose efficiency in normal mode (not in energy saver mode) is at least 94%.<sup>1746</sup>

### DEFINITION OF BASELINE EQUIPMENT

The baseline condition is an existing rectifier whose efficiency in normal mode (not in energy saver mode) is less than 90%.<sup>1747</sup>

### DEEMED LIFETIME OF EFFICIENT EQUIPMENT

The measure life is assumed to be 15 years.<sup>1748</sup>

### DEEMED MEASURE COST

The incremental cost is estimated at \$59 per kW of IT Load.<sup>1749</sup>

### LOADSHAPE

Loadshape is determined by the constant power draw by the Rectifier; default loadshape is Loadshape C53 – Flat.

### COINCIDENCE FACTOR

The coincidence factor for the rectifier is assumed to be 1.0 due to equipment operating during peak period.

---

<sup>1746</sup> Switching mode rectifier (SMR) technologies allows for efficiencies as high as 96% according to the DOE, Office of Energy Efficiency & Renewable Energy, High-Efficiency, Wide-Band Three-Phase Rectifiers and Adaptive Rectifier Management. Accessed: 12/05/19 <https://www.energy.gov/eere/amo/high-efficiency-wide-band-three-phase-rectifiers-and-adaptive-rectifier-management>

<sup>1747</sup> Mid-range efficiency for most low peak rectifiers (88%-92%) based on information from the DOE, Office of Energy Efficiency & Renewable Energy, High-Efficiency, Wide-Band Three-Phase Rectifiers and Adaptive Rectifier Management. Accessed: 12/05/19 <https://www.energy.gov/eere/amo/high-efficiency-wide-band-three-phase-rectifiers-and-adaptive-rectifier-management>

<sup>1748</sup> California Municipal Utilities Association. Savings Estimation Technical Reference Manual 2017, Third Edition. Section 8.12, p. 8–15.

<sup>1749</sup> Based on market study of twenty, 1600 Volt Bridge Rectifiers, as sourced from Mouser Electronics online marketplace. Accessed: 12/05/19. [https://www.mouser.com/Semiconductors/Discrete-Semiconductors/Diodes-Rectifiers/Bridge-Rectifiers/\\_/N-ax1mf?P=1yzzhysZ1yzzpaz](https://www.mouser.com/Semiconductors/Discrete-Semiconductors/Diodes-Rectifiers/Bridge-Rectifiers/_/N-ax1mf?P=1yzzhysZ1yzzpaz)

**Algorithm**

**CALCULATION OF ENERGY SAVINGS**

**ELECTRIC ENERGY SAVINGS**

$$\Delta kWh = kWh_{base} - kWh_{EE}$$

$$kWh_{base} = ((Load * H_{IT})/Eff_{base}) + ((Load * (1/ Eff_{base} - 1) * H_{Cool} * kW/Ton_{Cool} * 3412/12000)$$

$$kWh_{EE} = ((Load * H_{IT})/Eff_{EE}) + ((Load * (1/ Eff_{EE} - 1) * H_{Cool} * kW/Ton_{Cool} * 3412/12000)$$

Where:

- Load = Average IT load (output kW)  
= Actual, typically at 20% of equipment rated load<sup>1750</sup>
- H<sub>IT</sub> = Annual hours of operation of rectifier  
= 8760
- H<sub>cool</sub> = Annual cooling system hours of operation  
= Actual or defaults below:

System Size	Cooling Hours (H <sub>cool</sub> )
Small IT (≤ 50 kW) without air-side economizer	8760 hours <sup>1751</sup>
Small IT (> 50 kW) with air-side economizer	4380 hours <sup>1752</sup>

- Eff<sub>base</sub> = Efficiency of existing rectifier  
= Actual. If unknown assume 90%<sup>1753</sup>
- Eff<sub>EE</sub> = Efficiency of new rectifier  
= Actual. If unknown assume 94%
- kW/Ton<sub>cool</sub> = Cooling system efficiency (kW/Ton)

Cooling Equipment Type	Efficiency Calculation (kW/Ton <sub>cool</sub> )
Air-Cooled Chiller	kW/Ton <sub>Chiller</sub> + kW <sub>chilled water pump</sub> /Tons
Water-Cooled Chiller	kW/Ton <sub>Compressor</sub> + (kW <sub>chilled water pump</sub> + kW <sub>condensator water pump</sub> + kW <sub>cooling tower fans</sub> )/Tons
Direct Expansion System	12/EER

**SUMMER COINCIDENT PEAK DEMAND SAVINGS**

$$\Delta kW = kW_{base} - kW_{EE}$$

$$kW_{base} = ((Load * CF_{IT})/Eff_{base}) + ((Load * CF_{cool} * (1/ Eff_{base} - 1) * kW/Ton_{Cool} * 3412/12000)$$

<sup>1750</sup> Based on industry knowledge of large telecom company set up.

<sup>1751</sup> Small IT systems are assumed to have no air-side economizer and to operate continuously throughout the year.

<sup>1752</sup> Larger IT systems are assumed to have an air-side economizer that allows the cooling system to be turned off for half the year. This corresponds to approximately a 45°F changeover temperature, which is a conservative assumption.

<sup>1753</sup> Mid-range efficiency for most low peak rectifiers (88%-92%) based on information from the DOE, Office of Energy Efficiency & Renewable Energy, High-Efficiency, Wide-Band Three-Phase Rectifiers and Adaptive Rectifier Management.

$$\text{kWh}_{\text{EE}} = ((\text{Load} * \text{CF}_{\text{IT}})/\text{Eff}_{\text{EE}}) + ((\text{Load} * \text{CF}_{\text{cool}} * (1/\text{Eff}_{\text{EE}} - 1) * \text{kW}/\text{Ton}_{\text{Cool}} * 3412/12000))$$

Where:

$\text{CF}_{\text{IT}}$  = Coincidence factor of rectifier  
= 1.0

$\text{CF}_{\text{cool}}$  = Coincidence factor of cooling system  
= 0.82

**FOSSIL FUEL SAVINGS**

N/A

**WATER AND OTHER NON-ENERGY IMPACT DESCRIPTIONS AND CALCULATION**

N/A

**DEEMED O&M COST ADJUSTMENT CALCULATION**

N/A

**MEASURE CODE: CI-MSC-RECT-V03-230101**

**REVIEW DEADLINE: 1/1/2026**



## 4.8.20 Energy Efficient Hydraulic Oils - Provisional Measure

### DESCRIPTION

Industrial hydraulic systems use hydraulic oil to transfer input energy to output power. Hydraulic oils also protect critical components from premature wear. Energy efficient hydraulic oil lubricants meet these requirements and provide reduced energy consumption. Energy efficient hydraulic oils have a lower coefficient of friction which reduces the friction between two moving parts (rotating pump equipment and hydraulic oil). This lower coefficient of friction reduces the energy required to yield output power. Second, these oils have a high viscosity index which reduces the effect temperature has on the viscosity of the hydraulic oil. The high viscosity index allows constant viscosity over a range of operating temperatures which optimizes volumetric and mechanical efficiency at the pumps rated output. Additionally, energy efficient hydraulic oils reduce the operating temperature of the hydraulic system.

Manufacturers who use electric-motor-driven hydraulic systems have been found to reduce energy consumption by between 3 and 7%.

This measure was developed to be applicable to the following program types: NC, TOS and RF. If applied to other program types, the measure should be verified as a custom measure.

### DEFINITION OF EFFICIENT EQUIPMENT

This is applicable for small, medium, and large manufacturers in all climate zones using electric motors to power their hydraulic system both inside and/or outside conditioned areas; or for all hydraulic systems on mobile equipment in all climate zones on Illinois.

### DEFINITION OF BASELINE EQUIPMENT

The baseline equipment is defined as hydraulic systems using non-energy efficient industrial hydraulic oils which provides no energy efficiency benefits. In the formula below, the baseline equipment is where,  $E_i = \text{zero}$ .

### DEEMED LIFETIME OF EFFICIENT EQUIPMENT

The expected measure life is assumed to be 10 years.

The ability to reduce energy consumption (energy efficiency) is an inherent characteristic in the oil which does not deplete over time. As long as the energy efficient oil is in use, it will provide energy efficiency.

### DEEMED MEASURE COST

The actual incremental costs between an energy-efficient hydraulic oil and a standard hydraulic oil should be used.

### LOADSHAPE

Loadshape C14: Indust. 1-shift (8/5) (e.g., comp. air, lights)

Loadshape C15: Indust. 2-shift (16/5) (e.g., comp. air, lights)

Loadshape C16: Indust. 3-shift (24/5) (e.g., comp. air, lights)

Loadshape C17: Indust. 4-shift (24/7) (e.g., comp. air, lights)

### COINCIDENCE FACTOR

No coincidence factor though it is noted that reduced consumption for equipment will reduce the overall baseload power demand, especially if a construction operation or manufacturing operation demand more utility power in summer weather (e.g., construction ground work, rubber manufacturing, etc).

---



---

**Algorithm**

---

**CALCULATION OF ENERGY SAVINGS**

Savings are calculated based on a reduced coefficient of friction and the shear-stable high viscosity index value associated with energy-efficient hydraulic oils in hydraulic systems. The algorithm below for Energy Savings, is modeled after the Focus on Energy Emerging Technology Program M&V study.

**ELECTRIC ENERGY SAVINGS**

$$\Delta kWh = \text{MotorHP} * (0.746 \text{ kW/HP}) * (\% \text{MotorLoading} / \mu \text{Motor}) * \text{HOURS} * E_i$$

Where:

MotorHP = Rated horsepower of electric motor, summed when pumps are in series.  
 = Actual

%MotorLoading = Is dependent upon many factors including the part being manufactured, the polymer, the machine's specifications, and cycle time.  
 = Actual, calculated as (Average load / Full rated load)  
 = Estimated as 75%.<sup>1754</sup>

$\mu$ Motor = Motor efficiency  
 = Actual. If unknown, estimated as 92% for motors in size range typically used.<sup>1755</sup>

HOURS = Hours of operation per year  
 = Actual

$E_i$  = Efficiency improvement due to use of energy efficient hydraulic oils  
 = Actual. If not measured, assume 3.3%.<sup>1756</sup>

**SUMMER COINCIDENT PEAK DEMAND SAVINGS**

N/A

**FOSSIL FUEL SAVINGS**

N/A

**WATER AND OTHER NON-ENERGY IMPACT DESCRIPTIONS AND CALCULATION**

N/A

**DEEMED O&M COST ADJUSTMENT CALCULATION**

O&M savings from the necessary standard oil replacement over the lifetime of the energy efficient hydraulic oil (including oil cost, disposal costs, labor and avoided downtime) should be calculated. If additional savings for improved pump and valve lifetime can be demonstrated, these can also be included.

---

<sup>1754</sup> Most electric motors are designed to run at 50% to 100% of rated load, from Department of Energy "Determining Electric Motor Load & Efficiency", June 23, 2020.

<sup>1755</sup> Based on common size and type of motor - chart on pages 13-14, "Attachment C" of reference 9, the efficiency of a 50HP motor (TEFC type) at 1200 RPM is 92%. Or 75HP at 900 RPM at 75% TEFC type is 91.8%. These are common sizes and type for manufacturers.

<sup>1756</sup> Estimate based on review of a number of studies provided by ExxonMobil and saved in reference folders.

An example O&M cost calculation is provided below, relating to the standard hydraulic oil requiring 1 change out per year:

O&M Component	Cost
Oil cost	\$800
Oil disposal cost	\$80
Labor (4 hours per change at \$40/hr)	\$160
Downtime Production cost (2 hours at \$500 lost production cost per year)	\$1000
Total annual O&M benefit (1 change per year)	\$2040

**MEASURE CODE: CI-MSC-EEHO-V01-210101**

**REVIEW DEADLINE: 1/1/2023**

## 4.8.21 Energy Efficient Gear Lubricants - Provisional Measure

### DESCRIPTION

Industrial gear reduction systems use gear oil to transfer input energy to output power. Gear oils also protect critical components from premature wear. Energy efficient gear oil lubricants meet these requirements and provide reduced energy consumption. Energy efficient gear oils have a lower coefficient of friction which reduces the friction between two moving parts (rotating pump equipment and hydraulic oil). This lower coefficient of friction reduces the energy required to yield output power. Second, these oils have a high viscosity index which reduces the effect temperature has on the viscosity of the hydraulic oil. The high viscosity index allows constant viscosity over a range of operating temperatures which optimizes volumetric and mechanical efficiency at the pumps rated output. Additionally, energy efficient gear oils reduce the operating temperature of the gear-reduction gearbox.

Manufacturers who use electric-motor-driven gear-reduction gearboxes can reduce energy consumption by up to 1% per gear-mesh (e.g., 3% efficiency for a 3-reduction gearbox).

This measure was developed to be applicable to the following program types: NC, TOS and RF. If applied to other program types, the measure should be verified as a custom measure.

### DEFINITION OF EFFICIENT EQUIPMENT

This is applicable for small, medium, and large manufacturers in all climate zones using electric motors to power their gear reduction system both inside and/or outside conditioned areas; or for all gear reduction systems on mobile equipment in all climate zones on Illinois.

### DEFINITION OF BASELINE EQUIPMENT

The baseline equipment is defined as a gearbox using non-energy efficient industrial gear lubricants which provides no energy efficiency benefits. In the formula below, the baseline equipment is where,  $E_i = \text{zero}$ .

### DEEMED LIFETIME OF EFFICIENT EQUIPMENT

The expected measure life is assumed to be 10 years.

The ability to reduce energy consumption (energy efficiency) is an inherent characteristic in the oil which does not deplete over time. As long as the energy efficient oil is in use, it will provide energy efficiency.

### DEEMED MEASURE COST

The actual incremental costs between an energy-efficient and a standard gear lubricant should be used.

### LOADSHAPE

Loadshape C14: Indust. 1-shift (8/5) (e.g., comp. air, lights)  
Loadshape C15: Indust. 2-shift (16/5) (e.g., comp. air, lights)  
Loadshape C16: Indust. 3-shift (24/5) (e.g., comp. air, lights)  
Loadshape C17: Indust. 4-shift (24/7) (e.g., comp. air, lights)

### COINCIDENCE FACTOR

No coincidence factor though it is noted that reduced consumption for equipment will reduce the overall baseload power demand, especially if a construction operation or manufacturing operation demand more utility power in summer weather (e.g., construction ground work, rubber manufacturing, etc).

---



---

**Algorithm**

---

**CALCULATION OF ENERGY SAVINGS**

Savings are calculated based on a reduced coefficient of friction and the shear-stable high viscosity index value associated with energy-efficient gear oils in gear-reduction systems. The algorithm below for Energy Savings is modeled after the Focus on Energy Emerging Technology Program M&V study.

**ELECTRIC ENERGY SAVINGS**

$$\Delta kWh = \text{MotorHP} * (0.746 \text{ kW/HP}) * (\% \text{MotorLoading} / \mu \text{Motor}) * \text{HOURS} * E_i$$

Where:

MotorHP = Rated horsepower of electric motor, summed when pumps are in series.  
 = Actual

%MotorLoading = Is dependent upon many factors including the part being manufactured, the polymer, the machine's specifications, and cycle time.  
 = Actual, calculated as (Average load / Full rated load)  
 = Estimated as 75%.<sup>1757</sup>

$\mu$ Motor = Motor efficiency  
 = Actual. If unknown, estimated as 92% for motors in size range typically used.<sup>1758</sup>

HOURS = Hours of operation per year  
 = Actual

$E_i$  = Efficiency improvement due to use of energy efficient hydraulic oils  
 = Actual. If not measured, assume 1% per gear mesh.<sup>1759</sup>

**SUMMER COINCIDENT PEAK DEMAND SAVINGS**

N/A

**FOSSIL FUEL SAVINGS**

N/A

**WATER AND OTHER NON-ENERGY IMPACT DESCRIPTIONS AND CALCULATION**

N/A

**DEEMED O&M COST ADJUSTMENT CALCULATION**

O&M savings from the necessary standard oil replacement over the lifetime of the energy efficient gear oil (including oil cost, disposal costs, labor and avoided downtime) should be calculated. If additional savings for improved gear box lifetime can be demonstrated, these can also be included.

---

<sup>1757</sup> Most electric motors are designed to run at 50% to 100% of rated load, from Department of Energy "Determining Electric Motor Load & Efficiency", June 23, 2020.

<sup>1758</sup> Based on common size and type of motor - chart on pages 13-14, "Attachment C" of reference 9, the efficiency of a 50HP motor (TEFC type) at 1200 RPM is 92%. Or 75HP at 900 RPM at 75% TEFC type is 91.8%. These are common sizes and type for manufacturers.

<sup>1759</sup> Estimate based on review of a number of studies provided by ExxonMobil and saved in reference folders.

**MEASURE CODE: CI-MSC-EEGL-V01-210101**

**REVIEW DEADLINE: 1/1/2023**

## 4.8.22 Smart Sockets

### DESCRIPTION

Smart sockets achieve savings through the reduction of the standby load of the controlled appliance, as well as eliminating the operation of an appliance during unoccupied hours. The standby power consumption of home appliances and office equipment can be significantly reduced.

In a commercial office space, significant opportunity exists for savings from the reduction of plug loads, with power strips and timers being a key energy saving measure.<sup>1760</sup> Savings from smart sockets generally occurs during off-hours, when connected equipment continues to consume electricity while in standby mode or when off. Savings may also be achieved through the more precise scheduling of the appliance, so that it is not operating during unoccupied hours, though those savings have not been attempted to be quantified within this summary.

Smart sockets are ideal for all types of plugged-in devices such as small appliances (coffee maker, office heater, etc.), in-wall AC units, large office equipment, outlet lights, digital signs, decorative lighting, televisions, etc, though they provide the greatest energy savings when installed on equipment with higher wattage and standby power consumption. In a commercial office space, the shared photocopier is often the largest stand-alone user of electricity, with the highest standby power draw, so an ideal candidate for use with a smart socket. Note that a dedicated power supply is critical for your office photocopier.<sup>1761</sup> Also, note that the electrical amperage rating of the smart socket should be verified to suit the connected equipment. Desktop computers with peripheral equipment may be better served by an advanced power strip.

This measure was developed to be applicable to the following program types: DI, KITS. If applied to other program types, the measure savings should be verified.

### DEFINITION OF EFFICIENT EQUIPMENT

The efficient case is the use of a smart plug with a standby power wattage of 2W or less. Should be UL listed. (Simply Conserve Smart Socket SS-15A1-WiFi has a standby power of less than or equal to 0.7).

### DEFINITION OF BASELINE EQUIPMENT

The assumed baseline is an appliance or piece of office equipment plugged into an outlet (without a power strip) or into a standard power strip with surge protection that does not control connected loads. Note many ENERGY STAR appliances require power saving settings which will partially offset the savings potential of this measure. Where possible non-ENERGY STAR equipment should be plugged in to the socket to ensure savings are realized.

### DEEMED LIFETIME OF EFFICIENT EQUIPMENT

The assumed lifetime of the smart socket is 7 years.<sup>1762</sup>

### DEEMED MEASURE COST

For direct install, the actual full equipment and installation cost (including labor) and for kits the actual full equipment cost should be used. If unknown for kits, use \$9.00/each.<sup>1763</sup>

---

<sup>1760</sup> See Page 6 of New Buildings Institute, “Plug Load Savings Assessment: Part of the Evidence-based Design and Operations PIER Program,” California Energy Commission, Evidence-based Design and Operations PIER Program, March 2013.

<sup>1761</sup> From Ross Wiffler, “A Dedicated Power Supply is Critical for Your Office Copier”, Copiers & More, Small Business, Aug. 18<sup>th</sup>, 2015. <https://commonsensebusinesssolutions.com/a-dedicated-power-supply-is-critical-for-your-office-copier/>

<sup>1762</sup> This is an assumption consistent with 4.8.7 Advanced Power Strip – Tier 1 Commercial.

<sup>1763</sup> Based on cost from vendor of typical smart socket on the market, Simply Conserve Smart Socket by AM Conservation Group. 10 amp smart socket: \$8.92/each; 15 amp smart socket: \$9.00/each.

**LOADSHAPE**

Loadshape C47 – Standby Losses – Commercial Office<sup>1764</sup>

**COINCIDENCE FACTOR**

N/A due to no savings attributable to standby losses between 1 and 5 PM.

---

**Algorithm**

---

**CALCULATION OF ENERGY SAVINGS**

**ELECTRIC ENERGY SAVINGS**

$$\Delta kWh^{1765} = (((W_{Base} * OnAdj) - W_{Eff}) * (hrs_{wkday} - hrs_{wkday-open})) + (((W_{Base} * OnAdj) - W_{Eff}) * (hrs_{wkend} - hrs_{wkend-open}))/1000 * weeks/year * ISR$$

Where:

$W_{Base}$  = Standby power or On power consumption of connected appliance.

Use actual if known, or refer to tables below. If unknown, e.g. via kits, assume 9.4W<sup>1766</sup>

Appliances assumed to be in standby mode:

Controlled Equipment <sup>1767</sup>	Standby Power (W)
Coffee Maker	1.14
Television, CRT	3.06
Television, Rear Projection	6.97
Television, LCD <sup>1768</sup>	8.00
Set-top Box, DVR	36.68
Set-top Box, Digital Cable	17.83
Set-top Box, Satellite	15.66
Television/VCR	5.99
VCR	4.68
Computer, Desktop	2.84
Computer Notebook	8.90
Multifunction Device, Inkjet	5.26

<sup>1764</sup> As referenced in 4.8.7 Advanced Power Strip – Tier 1 Commercial, Loadshapes were calculated from empirical studies and compared to the existing loadshape in Volume 1, Table 3.5. The studies were: Acker, Brad *et al*, “Office Space Plug Load Profiles and Energy Saving Interventions,” 2012 ACEEE Summer Study on Energy Efficiency in Buildings.

Sheppy, M. *et al*, “Reducing Plug Loads in Office Spaces” Hawaii and Guam Energy Improvement Technology Demonstration Project, NREL/NAVFAC (January 2014).

<sup>1765</sup> Savings algorithm reconstructed from weekday and weekend savings information in Acker, Brad *et al*, “Office Space Plug Load Profiles and Energy Saving Interventions,” 2012 ACEEE Summer Study on Energy Efficiency in Buildings, and verified against savings in Acker *et al* and savings in: BPA, “Smart Power Strip Energy Savings Evaluation: Ross Complex,” (2011). Office stations are assumed to have zero or minimal standby losses during normal operating hours. Method shown in “Commercial Tier 1 APS Calculations – IL TRM.xlsx”.

<sup>1766</sup> Average connected wattage found in Guidehouse, ‘ComEd Small Business Kits CY2020 Impact Evaluation Report 2021-04-01 Final.pdf’.

<sup>1767</sup> See Standby Power Summary Table contained in “Standby Power”, Lawrence Berkeley National Laboratory, Building Technology and Urban Systems Division, <https://standby.lbl.gov/data/summary-table/>

<sup>1768</sup> From “iTECH evaluation on the SmartSocket,” ITECH Electronic Co., LTD, 1/28/19. IoT – Related Technical Articles. <https://www.itechate.com/uploadfiles/2019/01/201901281143214321.pdf>.



Controlled Equipment <sup>1767</sup>	Standby Power (W)
Multifunction Device, Laser	3.12
Scanner, Flatbed	2.48

Appliances assumed to be in on mode:

Controlled Equipment <sup>1769</sup>	On Power (W)
Light	10.4
Fan	70
Space Heater	450
Water Cooler	100

- OnAdj = Adjustment for wattages of appliances that are powered on during out of hours  
= 50%<sup>1770</sup> for appliances in on mode  
=100% for appliances in standby mode and for unknown
- W<sub>Eff</sub> = Standby power consumption of smart socket. If unknown, assume 0.7W<sup>1771</sup>.
- hr<sub>S<sub>wkday</sub></sub>
- hr<sub>S<sub>wkend</sub></sub>
- hr<sub>S<sub>wkday-open</sub></sub>
- hr<sub>S<sub>wkend-open</sub></sub>
- weeks/year = number of weeks per year  
= 52.2
- ISR = In Service Rate  
= Assume 0.969 for commercial Direct Install application<sup>1773</sup>  
= Assume 0.28 for kits that include two smart sockets<sup>1774</sup>  
= Assume 0.36 for kits that include one smart socket<sup>1775</sup>

<sup>1769</sup> See Standby Power Summary Table contained in “Standby Power”, Lawrence Berkeley National Laboratory, Building Technology and Urban Systems Division, <https://standby.lbl.gov/data/summary-table/>

<sup>1770</sup> In the absence of empirical data, a 50% adjustment for appliances assumed to be on during out of hours is applied.

<sup>1771</sup> Average smart socket wattage found in Guidehouse, ‘ComEd Small Business Kits CY2020 Impact Evaluation Report 2021-04-01 Final.pdf’.

<sup>1772</sup> Unknown hours are based on a Guidehouse review of open hours for 487 participants in this measure.

<sup>1773</sup> Based upon review of the PY2 and PY3 ComEd Direct Install Residential program surveys. This value could be modified based upon commercial application evaluation.

<sup>1774</sup> This ISR is based on the results of surveys of ComEd Small Business Kit recipients conducted in the Spring of 2021. This result includes the reduction in the installation rate from the survey respondents that indicated they did not install the application which is necessary to use the smart socket as intended.

<sup>1775</sup> This ISR is based on the results of the surveys of ComEd Small Business Kit recipients conducted in the Spring of 2021. It is based on an estimate of what the ISR would be if the kit only included a single socket even though all the kits distributed by ComEd included two sockets. Similar to the ISR for the two socket kits, this ISR accounts for the reduction in the installation rate

**For example**, a smart socket is direct installed with a LCD Television in an office open 9.6 hours per day (48 hours per week) on weekdays and 10 hours on weekends:

$$\begin{aligned}\Delta\text{kWh} &= (((8 * 1) - 0.7) * (106 - 48)) + (((8 * 1) - 0.7) * (62 - 10))/1000 * 52.2 * 0.969 \\ &= 40.6 \text{ kWh}\end{aligned}$$

**SUMMER COINCIDENT PEAK DEMAND SAVINGS**

N/A due to no savings attributable to standby losses between 1 and 5 PM.

**FOSSIL FUEL SAVINGS**

N/A

**WATER AND OTHER NON-ENERGY IMPACT DESCRIPTIONS AND CALCULATION**

N/A

**DEEMED O&M COST ADJUSTMENT CALCULATION**

N/A

**MEASURE CODE: CI-MSC-SSOC-V02-220101**

**REVIEW DEADLINE: 1/1/2025**

---

from the survey respondents that indicated they did not install the application which is necessary to use the smart socket as intended.

## 4.8.23 Lithium Ion Fork Truck Batteries

### DESCRIPTION

This measure applies to electric fork trucks used in commercial, industrial, and warehouse environments. Electric fork trucks with lithium ion battery systems are more efficient than electric fork trucks with traditional lead acid battery systems because the lithium ion batteries have lower internal resistance. This allows the batteries to transfer power faster, reduces waste heat, and reduces standby losses.

Electric fork trucks can be purchased with lithium ion battery systems or an existing electric fork truck can be retrofitted to use a lithium ion battery system. An electric fork truck can be converted to a lithium ion battery system by removing the lead acid battery and installing a battery case that includes a series of lithium ion batteries and the appropriate ballast to meet weight and balance specifications for the fork truck. The lithium ion battery case is a one-for-one equivalent replacement of the lead acid battery in respect to capacity, shape, and weight. The fork truck may require a new charger to work with the new lithium ion battery system. Electric fork trucks can also replace propane or diesel powered fork truck in a one to one scenario. Where a facility normally operates a fleet of fossil-fueled fork trucks a fossil-fuel baseline should be considered for any additional fork trucks that might be purchased beyond the current quantity of trucks operating at the facility.

This measure was developed to be applicable to the following program types: TOS and RF. If applied to other program types, the measure savings should be verified.

### DEFINITION OF EFFICIENT EQUIPMENT

Class I, Class II, or Class III fork trucks that are powered by lithium ion batteries with minimum 8-hour shift operation five days per week.

### DEFINITION OF BASELINE EQUIPMENT

Class I, Class II, or Class III fork trucks that are powered by lead acid batteries or fossil-fuels such as propane or diesel with minimum 8-hour shift operation five days per week.

### DEEMED LIFETIME OF EFFICIENT EQUIPMENT

15 years.<sup>1776</sup>

### DEEMED MEASURE COST

Costs will vary significantly based on the capacity and class of the fork truck. Costs for this measure should be determined by actual quotes obtained from manufacturers and estimated labor. If not available, it is estimated that a new lithium ion fork truck would cost \$34,400 compared with \$17,200 for a new lead-acid battery fork truck, \$24,200 for a propane and \$25,100 for a diesel fork truck.<sup>1777</sup>

Converting a lead acid battery fork truck to a lithium ion battery system would cost \$17,000.<sup>1778</sup>

### LOADSHAPE

Loadshape C14 - Indust. 1-shift (8/5) (e.g., comp. air, lights)

---

<sup>1776</sup> Lifetime of measure assumed to be limited by the lifetime of the lithium ion charger. See reference file Suzanne Foster Porter et al., "Analysis of Standards Options for Battery Charger Systems", (PG&E, 2010), 45.

<sup>1777</sup> Estimates for new lithium ion, propane and diesel from Dennis, Allen and Vairamohan, Bashkar. "EPRI Forklift (Lift Truck) Comparison with Capital Costs." Electric Power Research Institute. Accessed April 19, 2022.

<https://et.epri.com/ForkliftCalculator.html>. A new lead-acid battery is estimated to be approximately half the cost of a lithium ion, as suggested in Thomas, Pete. "Is a Lithium Ion Forklift Battery Worth the Extra Expense?" Toyota Material Handling Northern California. <https://www.tmhnc.com/blog/lithium-ion-forklift-battery-cost-and-runtime>.

<sup>1778</sup> Thomas, Pete. "Is a Lithium Ion Forklift Battery Worth the Extra Expense?" Toyota Material Handling Northern California. Accessed May 5, 2021. <https://www.tmhnc.com/blog/lithium-ion-forklift-battery-cost-and-runtime>.

Loadshape C15 - Indust. 2-shift (16/5) (e.g., comp. air, lights)

Loadshape C16 - Indust. 3-shift (24/5) (e.g., comp. air, lights)

Loadshape C17 - Indust. 4-shift (24/7) (e.g., comp. air, lights)

**COINCIDENCE FACTOR**

It is assumed that lead acid battery fork trucks are charged overnight. Therefore, the coincidence factor is assumed to be 0.0 for 1-shift and 2-shift operations and 1.0 for 3-shift and 4-shift operations.<sup>1779</sup>

---



---

**Algorithm**

---



---

**CALCULATION OF ENERGY SAVINGS**

**ELECTRIC ENERGY SAVINGS AND FOSSIL FUEL SAVINGS**

Non-fuel switch (baseline of lead-acid fork truck):

$$\Delta kWh = (CAP * DOD * CHG * (1/ EE_{LAB} - 1/EE_{LIB}))$$

Where:

CAP = Capacity of Battery

= Use actual battery capacity, otherwise use a default value of 35 kWh<sup>1780</sup>

DOD = Depth of Discharge

= Use actual depth of discharge, otherwise use a default value of 80%.<sup>1781</sup>

CHG = Number of Charges per year

= Use actual number of annual charges, if unknown use values below based on the type of operation

Standard Operations	Number of Charges per year
1-shift (8 hrs/day – 5 days/week)	520
2-shift (16 hrs/day – 5 days/week)	1,040
3-shift (24 hrs/day – 5 days/week)	1,560
4-shift (24 hrs/day – 7 days/week)	2,184

EE<sub>LAB</sub> = Energy Efficiency of Lead Acid Battery

= Use actual efficiency of battery for retrofit, for new or unknown use 46%<sup>1782</sup>

---

<sup>1779</sup> Matley, Ryan. May 29, 2009. "Industrial Battery Charger Energy Savings Opportunities." Emerging Technologies Program Application Assessment Report #0808. Pacific Gas & Electric.

<sup>1780</sup> Renquist, Jacob V., Brian Dickman, and Thomas H. Bradley. June 19, 2012. "Economic comparison of fuel cell powered forklifts to battery powered forklifts." International Journal of Hydrogen Energy, Volume 37, Issue 17.

<sup>1781</sup> Matley, Ryan. May 2009. "Measuring Energy Efficiency Improvements in Industrial Battery Chargers." Energy Systems Laboratory.

<sup>1782</sup> Abdulhameed, Alshaebi, Husam Dauod, and Sang Won Yoon. May 2017. "Evaluation of Different Forklift Battery Systems Using Statistical Analysis and Discrete Event Simulation." Industrial and Systems Engineering Conference. Pittsburg, PA.

EE<sub>LIB</sub> = Energy Efficiency of Lithium Ion Battery  
 = Use actual efficiency of battery, if unknown use 73%<sup>1782</sup>

**Fuel switch measures (baseline of propane or diesel fork truck):**

Fuel switch measures must produce positive total lifecycle energy savings (i.e., reduction in Btus at the premises) in order to qualify. This is determined as follows (note for early replacement measures the lifetime savings should be calculated by calculating savings for the remaining useful life of the existing equipment and for the remaining measure life):

$$\Delta\text{SiteEnergySavings (MMBtu)} = (\text{CAP} * \text{DOD} * \text{CHG} * (1/ \text{EE}_{\text{BASE}} - 1/\text{EE}_{\text{LIB}})) * 3,412/1,000,000$$

Where:

EE<sub>BASE</sub> = Energy efficiency of baseline fork truck. If unknown, assume the efficiency values below based on the type of fork truck. <sup>1783</sup>  
 = 20.4% for Propane  
 = 20.5% for Diesel  
 3,412 = Btu per kWh  
 1,000,000 = Btu per MMBtu

If SiteEnergySavings calculated above is positive, the measure is eligible.

Calculate savings as follows:

$$\Delta\text{kWh} = \Delta\text{SiteEnergySavings} * 1,000,000 / 3,412$$

Savings for each shift operation and baseline technology type using defaults provided above are provided below:

Standard Operations	Lead Acid	Diesel		Propane	
	Δ Elec (kWh)	ΔSiteEnergy Savings (MMBtu)	ΔSiteEnergy Savings (ΔkWh)	ΔSiteEnergy Savings (MMBtu)	ΔSiteEnergy Savings (ΔkWh)
1-shift (8 hrs/day – 5 days/week)	11,707	174	51,079	175	51,427
2-shift (16 hrs/day – 5 days/week)	23,414	349	102,158	351	102,855
3-shift (24 hrs/day – 5 days/week)	35,121	523	153,238	526	154,282
4-shift (24 hrs/day – 7 days/week)	49,169	732	214,533	737	215,995

<sup>1783</sup> Dennis, Allen and Vairamohan, Bashkar. “EPRI Forklift (Lift Truck) Comparison with Capital Costs.” Electric Power Research Institute. Accessed April 19, 2022. <https://et.epri.com/ForkliftCalculator.html>. Tank-to-wheel efficiency is based on dividing output electricity by input propane energy, assuming HHV of 91,333 BTU/gallon for propane and 138,500 BTU/gallon for diesel.

**SUMMER COINCIDENT PEAK DEMAND SAVINGS**

It is assumed there is zero peak demand savings.

**FOSSIL FUEL SAVINGS**

Calculation provided together with Electric Energy Savings above.

Water and Other Non-Energy Impact Descriptions and Calculation

N/A

**DEEMED O&M COST ADJUSTMENT CALCULATION**

Lithium ion batteries offer several O&M advantages over lead acid batteries. These benefits include, but are not limited to:

- Lithium ion batteries charge must faster, which results in less downtime.<sup>1784</sup>
- There is no requirement for changing out batteries at the end of a shift or having multiple spare batteries in stock.<sup>1784</sup> A 3-shift operation would require a facility to have three separate lead acid batteries for each fork truck, so they could swap out batteries at the end of each shift. A lithium ion battery is charged while still in the fork truck and can use opportunity charging during employee breaktime.
- Fewer maintenance issues and no requirement for battery watering<sup>1784</sup>
- Longer operating life.<sup>1785</sup> Lithium ion batteries can last nearly four times as long as lead acid batteries.

These benefits should be considered and evaluated on a project-by-project basis. It is estimated that lithium ion fork truck adoption saves a facility 65 labor hours per truck on an annual basis.<sup>1786</sup>

**COST EFFECTIVENESS SCREENING AND LOAD REDUCTION FORECASTING WHEN FUEL SWITCHING**

This measure can involve fuel switching from fossil fuel to electric.

For the purposes of forecasting load reductions due to fuel switch projects per Section 16-111.5B, changes in site energy use at the customer’s meter (using ΔkWh algorithm below) adjusted for utility line losses (at-the-busbar savings), customer switching estimates, NTG, and any other adjustment factors deemed appropriate, should be used.

The inputs to cost effectiveness screening should reflect the actual impacts on the electric and fuel consumption at the customer meter and, for fuel switching measures, this will not match the output of the calculation/allocation methodology presented in the “Fuel Switch Measures” section above. Therefore in addition to the calculation of savings claimed, the following values should be used to assess the cost effectiveness of the measure.

$$\begin{aligned} \Delta\text{Therms} &= [\text{Fossil Fuel Consumption Saved}] \\ &= [\text{CAP} * \text{DOD} * \text{CHG} * \text{EE}_{\text{LIB}}/\text{EE}_{\text{BASE}} * 3412/100,000] \\ \Delta\text{kWh} &= [\text{Electric Consumption Added}] \\ &= - [\text{CAP} * \text{DOD} * \text{CHG}] \end{aligned}$$

---

<sup>1784</sup> Abdulhameed, Alshaebi, Husam Dauod, and Sang Won Yoon. May 2017. “Evaluation of Different Forklift Battery Systems Using Statistical Analysis and Discrete Event Simulation.” Industrial and Systems Engineering Conference. Pittsburg, PA.

<sup>1785</sup> Mongird, Kendall, Viswanathan, Vilayanur V., Balducci, Patrick J., Alam, Md Jan E., Fotedar, Vanshika, Koritarov, V S., and Hadjerioua, Boualem. July 2019. "Energy Storage Technology and Cost Characterization Report". U.S. Department of Energy – HydroWires. <https://doi.org/10.2172/1573487>.

<sup>1786</sup> Abdulhameed, Alshaebi, Husam Dauod, and Sang Won Yoon. May 2017. “Evaluation of Different Forklift Battery Systems Using Statistical Analysis and Discrete Event Simulation.” Industrial and Systems Engineering Conference. Pittsburg, PA.

**MEASURE CODE: CI-MSC-LION-V03-230101**

**REVIEW DEADLINE: 1/1/2025**

## 4.8.24 Building Operator Certification

### DESCRIPTION

Building Operator Certification (BOC) is a training and certification program for commercial and public sector building operators. The curriculum teaches participants how to improve building comfort and efficiency by optimizing the building’s systems. BOC curriculums provide participants with knowledge about system operations, proper maintenance practices, occupant communication, and occupant comfort. Participants realize energy savings by utilizing the knowledge gained to improve their building operations through O&M and capital measures.

Evaluators in Illinois used differing levels of engagement with participants to estimate savings from the BOC training. While deeming savings does not fully capture the individual and varied actions that participants made as a result of their BOC training, it is a reasonable approach to better align the expected level of impacts and program expenditures with evaluation expenditures. Deemed savings for this measure represent a weighted average of analyses’ results from several Illinois BOC program evaluations. The evaluations estimated net savings and were developed per square foot of building area to account for the diversity of building sizes across Illinois. All savings estimating algorithms presented in this work paper are for net savings. Participants are required to complete a rigorous BOC course and can only claim savings for the facilities for which the individual taking the course are responsible.

The 2023 IL-TRM v11.0 will be used to verify savings for 2021 and 2022 participants, and these results will be included in the final 2022 BOC evaluations (produced by April 30, 2023). This will include 2 years’ worth of participants due to the annualization of savings for 2022 participants and the transition year of 2021 to the deemed approach.

This measure was developed to be applicable to the following program types: TOS. If applied to other program types, the measure savings should be verified.

### DEFINITION OF EFFICIENT EQUIPMENT

The efficient case is facilities operated by participants who complete a BOC training program. Participants must complete either the BOC Level I or Level II course and obtain a certificate of completion to be eligible for savings<sup>1787</sup>. Eligible BOC programs must cover the following subject areas:

#### BOC Level I

- Efficient Operation of HVAC Systems
- Measuring and Benchmarking Energy
- Efficient Lighting Fundamentals
- HVAC Controls Fundamentals
- Indoor Environmental Quality
- Common Opportunities for Low-Cost Operational Improvement

#### BOC Level II

- Building Scoping and Operational Improvements
- Optimizing HVAC Controls for Energy Efficiency
- Introduction to Building Commissioning
- Water Efficiency for Building Operators
- Project Peer Exchange

The BOC course must include formal instruction (i.e., lectures), individual projects and group exercises, bringing the total course time to at least 61 hours. Participants must obtain a training certificate of completion to be eligible for savings. Individuals who participate are not eligible for savings more than twice over the measure life, once for BOC Level I and another for BOC Level II. The entire floor area for any given building can only be used once over the measure life, and evaluators will verify attendees’ participation year-over-year.

The savings factors for this measure were developed based on an examination of savings using a weighted average approach from several similar BOC programs. The table below outlines the referenced evaluation studies, and key

<sup>1787</sup> Future evaluation research could explore savings differences between Level I and Level II participants.



parameters which were inputs to this measure characterization. It is important to note that the savings information referenced is net. Therefore, this measure does not require the additional application of a net-to-gross ratio.

No previous custom study of customer participation in BOC shall inform eligibility for this measure.

Utility or Program Administrator	Year	Participants	Average Building Area	MWh/ Participant	kW/ Participant	Therm/ Participant	Incremental Measure Costs (\$/Participant) <sup>1788</sup>
Ameren Illinois <sup>1789</sup>	2020	10	140,137	60.002	0.83	987	\$253.94
Ameren Illinois <sup>1790</sup>	2019	12	408,309	64.421	12.80	3,615	\$114.93
Ameren Illinois <sup>1791</sup>	2021	8	502,944	23.650	0.00	0	\$0.00
ComEd <sup>1792</sup>	2020	33	319,068	132.600	14.70	N/A	\$8,878.79
ComEd <sup>1793</sup>	2021	2	517,250	20.755	1.55	N/A	\$9,310.50
Nicor Gas <sup>1794</sup>	2021	3	517,250	0.000	0.00	234	\$0.00
Weighted Average <sup>1795</sup>			344,708	91.994	10.00	1,635	\$4,640.29

#### DEFINITION OF BASELINE EQUIPMENT

The baseline is building operations as they existed before the participant completed the BOC training course.

#### DEEMED LIFETIME OF EFFICIENT EQUIPMENT

The measure life for BOC savings is 13 years<sup>1796</sup>. Based on analyzed research, assume 42%<sup>1797</sup> of BOC savings are derived from O&M measures that have a 4-year measure life<sup>1798</sup>. This should be handled similar to other midlife adjustments, where after 4 years, a midlife adjustment factor of 58% is applied for the remaining nine years of the measure life.

<sup>1788</sup> Total incremental measure costs from the evaluation, net of O&M adjustments (if applicable), divided by the number of BOC participants.

<sup>1789</sup> Opinion Dynamics, ‘Ameren Illinois Company 2020 Business Program Impact Evaluation Report, Final’, April 28<sup>th</sup> 2021.

<sup>1790</sup> Opinion Dynamics, ‘Ameren Illinois Company 2019 Business Program Impact Evaluation Report, Final’, April 30<sup>th</sup> 2020.

<sup>1791</sup> Opinion Dynamics, ‘Ameren Illinois Company 2019 Business Program Impact Evaluation Report, Final’, April 29<sup>th</sup> 2022.

<sup>1792</sup> The ComEd evaluation includes both 2018 and 2019 participants. The interview sample did not stratify by program year, so the savings per participant are the same for each year. Guidehouse, ‘ComEd Building Operator Certification Pilot Impact Evaluation Report’, April 12<sup>th</sup>, 2021.

<sup>1793</sup> Guidehouse, ‘ComEd Building Operator Certification Pilot Impact Evaluation Report’, April 19<sup>th</sup>, 2022.

<sup>1794</sup> Guidehouse completed follow-up interviews with 2018 – 2020 participants from ComEd’s program which also had gas service. Three interviews were completed, and all were Nicor Gas customers who completed no cost scheduling and usage tracking. The savings for these participants was calculated following the methodology used to determine the savings for ComEd’s CY2022 Building Operator Certification Pilot.

<sup>1795</sup> The weighted average numbers are used to determine the savings parameters within this measure. The savings parameters are set so the participated weighted average savings using the TRM algorithm, including the building area cap, equals the participant weighted average savings from the referenced evaluation studies.

<sup>1796</sup> Average measure life of capital measures from the ComEd CY2020 evaluation.

<sup>1797</sup> Weighted average from referenced evaluation studies which outlined lifetime information.

<sup>1798</sup> EUL for operational updates when the controls type is unknown. See Attachment B:Effective Useful Life for Custom Measure. Effective Useful Life for Retro-commissioning and Behavior Programs memo by Guidehouse, September 17, 2019.

**DEEMED MEASURE COST**

The deemed training measure cost is \$1,695.<sup>1799</sup> In addition, the incremental cost of capital and O&M measures should also be included. If unknown, use an incremental measure cost of \$0.014/ft<sup>2</sup>.<sup>1800</sup>

**LOADSHAPE**

C23 – Commercial Ventilation

**COINCIDENCE FACTOR**

The demand savings factor (C<sub>d</sub>) is already based upon coincident savings, and thus there is no additional coincidence factor for this characterization.

---

**Algorithm**

---

**CALCULATION OF ENERGY SAVINGS**

**ELECTRIC ENERGY SAVINGS**

$$\Delta kWh = C_e * Area$$

Where

Area = Building area operated by the participant. The maximum eligible area per participant is 500,000 ft<sup>2</sup>. In the event there are multiple participants who operate the same building (i.e. service address), or group of buildings, the program administrator can only claim savings on building square footage once (i.e., they cannot claim savings based on the same square footage for multiple participants), unless the managed square footage exceeds 500,000 ft<sup>2</sup>; in which case, the program administrator can continue to claim savings up to the 500,000 ft<sup>2</sup> per participant cap until the total square footage has been accounted for.

C<sub>e</sub> = unit area kWh savings constant per participant<sup>1801</sup>, 0.274 kWh/ft<sup>2</sup>/participant

**SUMMER COINCIDENT PEAK DEMAND SAVINGS**

$$kW = C_d * Area / 1000$$

Where

C<sub>d</sub> = Unit demand savings constant<sup>1802</sup>, 0.03 W/ft<sup>2</sup> (capped)/participant

1000 = unit conversion from W to kW

**FOSSIL FUEL SAVINGS**

$$Therms = C_g * Area$$

---

<sup>1799</sup> The current price to take the BOC training and certification in Illinois. <https://www.boccentral.org/training/illinois>. Accessed May 2022.

<sup>1800</sup> Based on evaluated measure incremental costs, net of O&M adjustments when available, from Ameren Illinois and ComEd BOC programs in Illinois.

<sup>1801</sup> Average net savings per participant from the evaluations referenced. See table of evaluations in the Definition of Efficient Equipment section of this measure.

<sup>1802</sup> Average net demand savings per participant from the evaluations referenced. See table of evaluations in the Definition of Efficient Equipment section of this measure.

Where

$C_g$  = Unit gas savings constant<sup>1803</sup>, 0.0046 therms/ft<sup>2</sup> (capped)/participant

**WATER AND OTHER NON-ENERGY IMPACT DESCRIPTIONS AND CALCULATION**

N/A

Water and other non-energy impacts could be added in future updates.

**DEEMED O&M COST ADJUSTMENT CALCULATION**

N/A

**MEASURE CODE: CI-MSC-BOC-V02-230101**

**REVIEW DEADLINE: 1/1/2024**

---

<sup>1803</sup> Average net natural gas savings per participant from the evaluations referenced. See table of evaluations in the Definition of Efficient Equipment section of this measure.

## 4.8.25 Warm-Mix Asphalt Chemical Additives

### DESCRIPTION

Warm-Mix Asphalt (WMA) is the name for a variety of technologies that allow for production and placement of asphalt at temperatures lower than traditional Hot-Mix Asphalt (HMA). The production temperature of WMA is typically 25°F to 90°F below that of HMA, resulting in reduced energy consumption. The actual temperature reduction depends upon the warm mix technology used. Currently, there are three categories of WMA technologies: asphalt foaming technologies, organic additives, and chemical additives.

The asphalt foaming technologies include a variety of processes to foam asphalt, including water-injecting systems, damp aggregate, or the addition of a hydrophilic material such as a zeolite. In the asphalt plant, the water turns to steam, disperses throughout the asphalt, and expands the binder, providing a corresponding temporary increase in volume and fluids content, similar in effect to increasing the binder content. Chemical additives often include surfactants that aid in coating and lubrication of the asphalt binder in the mixture. Lastly, organic additives are typically special types of waxes that cause a decrease in binder viscosity above the melting point of the wax.

In addition to energy savings, using WMA in place of HMA reduces greenhouse gas emissions and provides multiple non-energy benefits, such as better compaction, cool-weather paving, longer haul distances, and improved working conditions for the paving crew (reduction of fumes and odors). Warm-mix chemical additives allow for the mixing and placement of asphalt at temperatures lower than traditional HMA while maintaining similar strength, durability, and performance characteristics.

This measure is applicable to the industrial market with the end user in the transportation sector. WMA can be used in any climate, as the lower mix temperature allows WMA to be used in cooler ambient conditions than traditional HMA.

This measure was developed to be applicable to the following program types: TOS. If applied to other program types, the measure savings should be verified.

### DEFINITION OF EFFICIENT EQUIPMENT

The efficient case is WMA. WMA is generally produced at temperatures ranging from 25°F to 90°F lower than HMA.<sup>1804</sup>

General WMA technologies can be categorized as chemical additives, organic additives, and water-based foaming methods. Chemical additives reduce the internal friction between aggregate particles and thin films of binders when subjected to high shear rates during mixing and high shear stress during compaction. In contrast, the other two WMA methods rely on reduction of binder viscosity.

### DEFINITION OF BASELINE EQUIPMENT

The baseline case is traditional HMA. HMA is traditionally mixed between 280°F and 320°F.<sup>1805</sup>

### DEEMED LIFETIME OF EFFICIENT EQUIPMENT

The measure life is 1 year. Savings occur during production, and last only as long as the production runs. Since savings and costs scale to tons of asphalt production, a 1-year measure life appropriately tracks lifecycle savings.

---

<sup>1804</sup> West, R.C., M.C. Rodezno, G. Julian, B.D. Prowell, B. Frank, L.V. Osborn, & A.J. Kriech (2014). "NCHRP Report 779:Field Performance of Warm-Mix Asphalt Technologies. Transportation Research Board of the National Academies", Washington, D.C. doi:10.17226/22272.

<sup>1805</sup> West, R.C., M.C. Rodezno, G. Julian, B.D. Prowell, B. Frank, L.V. Osborn, & A.J. Kriech (2014). "NCHRP Report 779:Field Performance of Warm-Mix Asphalt Technologies. Transportation Research Board of the National Academies", Washington, D.C. doi:10.17226/22272.

**DEEMED MEASURE COST**

The costs of WMA depend primarily on the type of WMA technology that is used. Of the WMA technology options, water-injection asphalt foaming typically have the lowest cost per ton. Water injection WMA technologies have a lower incremental cost at around \$0.08 per ton.<sup>1806</sup>

Compared to other WMA technologies, additive based WMA technologies increase the mix costs by \$2.50 per ton<sup>1807</sup> due to the cost of chemicals and freight costs.

**LOADSHAPE**

N/A

**COINCIDENCE FACTOR**

N/A

---

**Algorithm**

---

**CALCULATION OF ENERGY SAVINGS**

Energy savings are dependent on multiple factors that primarily affect the production of WMA. The following factors have been identified as the primary contributors to energy consumption:

- Mixing drum temperature
- Additive type

**ELECTRIC ENERGY SAVINGS**

N/A.

**SUMMER COINCIDENT PEAK DEMAND SAVINGS**

N/A.

**FOSSIL FUEL SAVINGS**

Average temperature reduction achieved by plants that reduce mix production temperature when using WMA must be determined to estimate reductions in energy consumption. In practice, WMA production temperatures when using water-injection foaming technologies are typically about 25°F lower than those for hot mix asphalt (HMA) using the same mix design. WMA produced with additives tends to have substantially lower mixing temperatures. For the purpose of estimating energy savings, a temperature difference of 50°F is assumed for additive-type WMA compared to HMA using the same mix design.

$$therms_{savings} = tons \times SF$$

Where:

- tons = Tons of asphalt produced
- SF = WMA production savings factor (therms/ton)

---

<sup>1806</sup> West, R.C., M.C. Rodezno, G. Julian, B.D. Prowell, B. Frank, L.V. Osborn, & A.J. Kriech (2014). "NCHRP Report 779:Field Performance of Warm-Mix Asphalt Technologies. Transportation Research Board of the National Academies", Washington, D.C. doi:10.17226/22272.

<sup>1807</sup> West, R.C., M.C. Rodezno, G. Julian, B.D. Prowell, B. Frank, L.V. Osborn, & A.J. Kriech (2014). "NCHRP Report 779:Field Performance of Warm-Mix Asphalt Technologies. Transportation Research Board of the National Academies", Washington, D.C. doi:10.17226/22272.

- = 1100 Btu/Δ°F/ton<sup>1808</sup>
- = 0.011 therms/Δ°F/ton (1100 Btu/Δ°F/ton/100,000 – Conversion factor from Btu to therm)
- = See Table 2 for SF for Water Injection Foaming and Additives

**Table 8 Energy Savings by mixing temperature reduction**

WMA Production Technology	[A] Energy Savings (therms/Δ°F/ton)	[B] Temperature Reduction (°F)	[C] = [A]*[B] SF (therms/ton)
Water Injection Foaming	0.011	25	0.275
Additives	0.011	50	0.605
Custom Documented	0.011	Custom	Calculated

**Example:**

A plant producing 1,000 ton asphalt everyday now decides to adopt additives for energy savings and non energy benefits. The savings for that plant will be computed:

Savings = 1,000 tons \* 0.605 (therms/ton) from table # 2. = 605 therms saved.

**WATER AND OTHER NON-ENERGY IMPACT DESCRIPTIONS AND CALCULATION**

In addition to reduced energy consumption, reduction in production temperatures results in reduced greenhouse gas emissions from the combustion process and any emissions from the mixed asphalt. The reduction of emissions, fumes, and odors results in a healthier work environment for production operators, truck drivers, and application workers. The lower temperature mix also allows for an extended paving season, night paving, and longer hauling distances for the WMA in comparison to HMA with faster application times.

**DEEMED O&M COST ADJUSTMENT CALCULATION**

N/A

**MEASURE CODE: CI-MSC-WMIX-V01-220101**

**REVIEW DEADLINE: 1/1/2025**

<sup>1808</sup> West, R.C., M.C. Rodezno, G. Julian, B.D. Prowell, B. Frank, L.V. Osborn, & A.J. Kriech (2014). "NCHRP Report 779:Field Performance of Warm-Mix Asphalt Technologies. Transportation Research Board of the National Academies", Washington, D.C. doi:10.17226/22272.

## 4.8.26 Energy Efficient Hand Dryers

### DESCRIPTION

This measure consists of installing efficient hand dryers that save energy by drying with air movement, using motion sensors, and reducing drying time. Energy efficient hand dryers use less energy per dry than standard hand dryers. Hand dryers are applicable in retail, commercial, and industrial settings.

This measure was developed to be applicable to the following program types: TOS, ERET. If applied to other program types, the measure savings should be verified.

### DEFINITION OF EFFICIENT EQUIPMENT

To qualify for this measure, a hand dryer must be motion operated with rated load of 1,500 W or less.

### DEFINITION OF BASELINE EQUIPMENT

The baseline equipment for this measure is a push-button operated hand dryer with connected load in excess of 1,500 Watts.

### DEEMED LIFETIME OF EFFICIENT EQUIPMENT

The measure life for a new energy efficient hand dryer is 10 years<sup>1809</sup>.

### DEEMED MEASURE COST<sup>1810</sup>

Incremental cost is \$483. Baseline cost for a hand dryer is \$368. Efficient cost for an efficient hand dryer is \$851.

### LOADSHAPE

Loadshape C02 - Commercial Electric DHW

### COINCIDENCE FACTOR

Formula of Coincidence Factor is as follows:

$$CF = \frac{\text{Cycle Time per Use} * \text{Use per Day} * \text{Site Occupied Days per Year}}{\text{Site Occupied Hours per Day} * 365}$$

---

<sup>1809</sup> Based on studies conducted by two separate parties; Comparative Environmental Life Cycle Assessment of Hand Drying Systems by Quantis (pg 2) and Guidelines to Reduce/Eliminate Paper Towel Use by Installing Electric Hand Dryers by Partners in Pollution Prevention P3 (pg 17).

<sup>1810</sup> Cost is the average retail costs for 16 baseline and 10 efficient hand dryers. See *Hand\_Dryer\_Analysis.xlsx*. Cost source: RestroomDirect.com

Where:

Usage	Example Building Types	Cycles per Day <sup>1811</sup>	Occupied Days per Year (DPY) <sup>1812</sup>	Occupied Hours per Day <sup>1813</sup>	Coincidence Factor (CF)
<b>Low</b>	Office, Warehouse	50	250	8	0.04
<b>Moderate</b>	Restaurant, Small Grocery, Small Retail	125	365	15	0.09
<b>High – &lt;12 hr/day</b>	K-12 School, University, Theater, Conference Center	250	200	9	0.16
<b>High – &gt;=12 hr/day</b>	Large Grocery, Retail Department Store	375	365	13	0.29
<b>Heavy - Intermittent</b>	Stadium, Theater, Place of Worship	250	80	6	0.10
<b>Heavy Duty - 24/7</b>	Transportation Center, Airport	750	365	23	0.34

---

**Algorithm**

---

**CALCULATION OF ENERGY SAVINGS**

**ELECTRIC ENERGY SAVINGS**

$$\Delta kWh = CPD * DPY * \frac{(Watts_{Base} * CycleTime_{Base} - Watts_{EE} * CycleTime_{EE})}{(3600 \frac{sec}{hr} * 1000 \frac{Watts}{kW})}$$

Where:

- CPD = Number of cycles per day.  
= If not known, use assumption as defined in Coincidence Factor section.
- DPY = Number of days the facility operates per year.  
= If not known, use assumption as defined in Coincidence Factor section.
- Watts = Unit wattage.  
= Actual. If not known, use assumption from the table below.

<sup>1811</sup> Guidehouse, Inc. Engineering Estimate, 2022

<sup>1812</sup> Illinois TRM v9.0, Days per year, from 4.3.2 Low Flow Faucet Aerators

<sup>1813</sup> Occupancy based on Lighting HOU from Section 4.5, combined with days per year from Section 4.3.2.



Assumptions	Power (watts)

Cycle Time = Runtime seconds per use.  
 = Actual. If not known, use assumption from the table below.

Assumptions	Cycle Time (seconds)
Baseline <sup>1816</sup>	37
Efficient <sup>1817</sup>	12

For example, a new efficient hand dryer replacing a baseline hand dryer at a large grocery store, with unknown cycles per day and unknown days per year:

$$\Delta\text{kWh} = (375 * 365 * (2,036 * 37 - 1,066 * 12)) / (3600 * 1000)$$

$$= 2378 \text{ kWh}$$

**SUMMER COINCIDENT PEAK DEMAND SAVINGS**

$$\Delta\text{kW\_Peak} = \frac{(Watts_{Base} - Watts_{EE})}{1000} * CF$$

Where:

- Watts<sub>Base</sub> = As defined in section above.
- Watts<sub>EE</sub> = As defined in section above.
- CF = Coincidence Factor as defined in Coincidence Factor section (shown here for convenience):

$$CF = \frac{\text{Cycle Time per Use} * \text{Use per Day} * \text{Site Occupied Days per Year}}{\text{Site Occupied Hours per Day} * 365}$$

Where:

<sup>1814</sup> CLEAR result survey of 24 hand dryers in convenience stores in Arkansas. See *Hand\_Dryer\_Analysis.xlsx*.

<sup>1815</sup> CLEAR result cost/specification survey of 10 unique efficient hand dryers. See *Hand\_Dryer\_Analysis.xlsx*.

<sup>1816</sup> CLEAR result survey of 24 hand dryers in convenience stores in Arkansas. See *Hand\_Dryer\_Analysis.xlsx*.

<sup>1817</sup> CLEAR result cost/specification survey of 10 unique efficient hand dryers. See *Hand\_Dryer\_Analysis.xlsx*.

Usage	Example Building Types	Cycles per Day <sup>1818</sup>	Occupied Days per Year (DPY) <sup>1819</sup>	Occupied Hours per Day <sup>1820</sup>	Coincidence Factor (CF)
Low	Office, Warehouse	50	250	8	0.04
Moderate	Restaurant, Small Grocery, Small Retail	125	365	15	0.09
High – <12 hr/day	K-12 School, University, Theater, Conference Center	250	200	9	0.16
High – >=12 hr/day	Large Grocery, Retail Department Store	375	365	13	0.29
Heavy - Intermittent	Stadium, Theater, Place of Worship	250	80	6	0.10
Heavy Duty - 24/7	Transportation Center, Airport	750	365	23	0.34

For example, a new efficient hand dryer replacing a baseline hand dryer at a large grocery store, with unknown cycles per day and unknown days per year:

$$\begin{aligned} \Delta kW &= ((2,036 - 1,066)/1000)*0.29 \\ &= 0.28 \text{ kW} \end{aligned}$$

**FOSSIL FUEL SAVINGS**

N/A

**WATER AND OTHER NON-ENERGY IMPACT DESCRIPTIONS AND CALCULATION**

N/A

**DEEMED O&M COST ADJUSTMENT CALCULATION**

N/A

**MEASURE CODE: CI-MSC-EEHD-V02-230101**

**REVIEW DEADLINE: 1/1/2026**

<sup>1818</sup> Guidehouse, Inc. Engineering Estimate, 2022

<sup>1819</sup> Illinois TRM v9.0, Days per year, from 4.3.2 Low Flow Faucet Aerators

<sup>1820</sup> Occupancy based on Lighting HOU from Section 4.5, combined with days per year from Section 4.3.2.

## 4.8.27 C&I Air Sealing

### DESCRIPTION

Note- this measure provides a comprehensive approach for various commercial air sealing opportunities. A prescriptive approach for door sweeps only is provided in measure 4.8.16 C&I Weather Stripping.

This Air Sealing Measure incorporates a wide variety of products and procedures that reduce unwanted uncontrolled outdoor air infiltration into commercial or industrial buildings. Unwanted outdoor air causes significant increases in both heating and cooling costs throughout most of the year, and causes unwanted introduction of dust and odors into the building. This outdoor air infiltration is caused by both wind blowing against one or more sides of the building, and also through thermal stack effects in tall buildings that cause infiltration on lower floors and exfiltration on upper floors.

This measure applies to all existing commercial and industrial buildings that utilize mechanical heating and/or cooling to maintain occupant comfort. Identifying the exact length and width of cracks and holes in a building is difficult to do accurately. Similarly, conducting a building pressurization test using multiple blower doors or programming the air handling equipment to pressurize a building is also impractical in most situations. Therefore, this measure's savings calculations are instead based primarily on deemed values of air leakage reduction per unit length or unit area of air sealing retrofits installed.<sup>1821</sup> If a blower door or air handler pressurization and measurement test can be done both before and after air sealing, the amount of air cfm reduction, adjusted to 50 pascals of pressure differential, may be directly inserted into the 'Annual Avg infiltration CFM Saved' value to determine annual energy savings.

This measure was developed to be applicable to the following program types: RF

If applied to other program types, the measure savings should be verified.

### DEFINITION OF EFFICIENT EQUIPMENT

Air sealing materials and diagnostic testing should meet all eligibility program qualification criteria. If applicable, the initial and final tested leakage rates should be performed in such a manner that the identified reductions can be properly discerned, particularly in situations wherein multiple building envelope measures may be implemented simultaneously.

### DEFINITION OF BASELINE EQUIPMENT

The baseline condition of a building upon first inspection significantly impacts the opportunity for cost-effective energy savings through air-sealing.

If applicable and feasible, the existing air leakage rate for an existing building may be determined through approved and appropriate test methods using either blower doors or air handling units programmed to pressurize the building. Outdoor air flow quantities and simultaneous measurements of building differential pressure (inside vs outside) must be measured using approved methods and adjusted to values at 50 pascals differential.

Alternatively, if actual leakage rates cannot be measured, air leakage savings may be deemed using quantities of air leakage lengths or quantities based on inspection of the building. Lengths of cracks to be filled, quantities of leaky doors or windows to be sealed, etc. are documented and prescriptive, deemed savings rates are used to estimate savings.

---

<sup>1821</sup> ASHRAE, 2001 AHSRAE Handbook – Fundamentals, Chapter 26, Table 1. Effective Air Leakage Areas (Low-Rise Residential Applications Only).

**DEEMED LIFETIME OF EFFICIENT EQUIPMENT**

The expected measure life is assumed to be 20 years.<sup>1822</sup>

**MEASURE COST**

Use actual cost of air sealing measures installed, if available. If actual costs are unknown, use estimated costs from table below multiplied by the number of units of each application installed:

Technology	Application	Unit Definition	Unit Cost Estimate <sup>1823</sup>
Weather Stripping	Single Door - Weather Stripping, Sweep	Enter Number of Doors Retrofitted	\$37
	Double Doors - Weather Stripping	Enter Number of Double Door Sets Retrofitted	\$166
	Casement Window - Weather Stripping	Enter Lin. Ft. of Crack Retrofitted	\$5
	Double Horizontal Slider, Wood - Weather Stripping	Enter Lin. Ft. of Crack Retrofitted	\$5
	Double-Hung - Weather Stripping	Enter Lin. Ft. of Crack Retrofitted	\$5
	Double-Hung, with Storm Window - Weather Stripping	Enter Lin. Ft. of Crack Retrofitted	\$5
	Roof-Wall Intersection, Block Seal	Enter Lin. Ft. of Crack Retrofitted	\$10
	Roof-Wall Intersection, Seal Paint	Enter Lin. Ft. of Crack Retrofitted	\$23
	Roof-Wall Intersection, Seal	Enter Lin. Ft. of Crack Retrofitted	\$6
	Piping/Plumbing/Wiring Penetrations - Sealing	Enter Number of Penetrations Retrofitted	\$50
Caulking	Caulking, External Block	Enter Lin. Ft. of Crack Retrofitted	\$12
	Caulking, Internal Seal	Enter Lin. Ft. of Crack Retrofitted	\$6
Attic Sealing	Attic Bypass Air Sealing, Block, Seal	Each	\$386
	Attic Bypass Air Sealing, Seal	Each	\$249
	Retrofit Existing Attic Hatch	Each	\$223
Gasket	Exterior Wall Outlet Penetrations - Gasket	Enter Number of Outlets Retrofitted	\$5
Avg Caulking / Weather Stripping	Average Window/Door Caulking / Weather Stripping	Enter Lin. Ft. of Crack Retrofitted	\$10

**LOADSHAPE**

- Loadshape C01 – Commercial Electric Cooling
- Loadshape C03 – Commercial Cooling
- Loadshape C04 – Commercial Electric Heating
- Loadshape C05 – Commercial Electric Heating and Cooling
- Loadshape C23 – Commercial Ventilation

<sup>1822</sup> As recommended in Navigant ‘ComEd Effective Useful Life Research Report’, May 2018.

<sup>1823</sup> Typical project costs from quotation for large commercial air sealing project in Northeast (site: Concord, NH). All unit prices taken from BE Retrofit quote, October 2021.

**COINCIDENCE FACTOR**

The summer peak coincidence factor for cooling is provided in two different ways below. The first is used to estimate peak savings during the utility peak hour and is most indicative of actual peak benefits, and the second represents the *average* savings over the defined summer peak period, and is presented so that savings can be bid into PJM’s capacity market. Both values provided are based on analysis of Itron eShape data for Missouri, calibrated to Illinois loads, supplied by Ameren.

- CF<sub>SSP</sub> = Summer System Peak Coincidence Factor for Commercial cooling (during system peak hour)  
= 91.3% <sup>1824</sup>
- CF<sub>PJM</sub> = PJM Summer Peak Coincidence Factor for Commercial cooling (average during peak period)  
= 47.8% <sup>1825</sup>

---

**Algorithm**

---

**CALCULATION OF ENERGY SAVINGS**

**ELECTRIC ENERGY SAVINGS**

- $\Delta kWh = \Delta kWh_{cooling} + \Delta kWh_{heatingElectric} + \Delta kWh_{heatingFurnace}$
- $\Delta kWh_{cooling}$  = If building is cooled, reduction in annual cooling requirement due to air sealing  
=  $1.08 * Infiltration\_CFM\_Saved * CDD55/yr * 24 / 1000 / \eta_{Cool} * \%Cool$
- $\Delta kWh_{heatingElectric}$  = if building is electrically heated, reduction in annual heating requirement due to air sealing  
=  $1.08 * Infiltration\_CFM\_Saved * HDD55/yr * 24 / \eta_{Heat} / 3,412 * \%ElectricHeat$
- $\Delta kWh_{heatingGas}$  = If gas furnace or gas boiler heat, kWh savings for reduction in combustion fan run time  
=  $\Delta Therms * F_e * 29.3$

Where:

- 1.08 = Specific heat of air x density of inlet air @ 70F x 60 min/hr in BTU/hr-F-CFM
- Infiltration\_CFM\_Saved = Annual average CFM of outdoor air infiltration reduced due to air sealing measures implemented  
= Calculated EITHER by sum of applicable values from table below multiplied by the quantities of each item implemented <sup>1826</sup>

Technology	Application	Delta CFM50 per Unit	Unit Definition
Weather Stripping	Single Door - Weather Stripping	25.500	Enter Number of Doors Retrofitted
	Double Doors - Weather Stripping	0.730	Enter Sq. Ft. of Both Doors Retrofitted

<sup>1824</sup> Based on analysis of Itron eShape data for Missouri, calibrated to Illinois loads, supplied by Ameren. The AC load during the utility’s peak hour is divided by the maximum AC load during the year.

<sup>1825</sup> Based on analysis of Itron eShape data for Missouri, calibrated to Illinois loads, supplied by Ameren. The average AC load over the PJM peak period (1-5pm, M-F, June through August) is divided by the maximum AC load during the year.

<sup>1826</sup> ASHRAE, 2001 AHSRAE Handbook – Fundamentals, Chapter 26, Table 1. Effective Air Leakage Areas (Low-Rise Residential Applications Only).

Technology	Application	Delta CFM50 per Unit	Unit Definition
	Casement Window - Weather Stripping	0.360	Enter Lin. Ft. of Crack Retrofitted
	Double Horizontal Slider, Wood - Weather Stripping	0.473	Enter Lin. Ft. of Crack Retrofitted
	Double-Hung - Weather Stripping	1.618	Enter Lin. Ft. of Crack Retrofitted
	Double-Hung, with Storm Window - Weather Stripping	0.164	Enter Lin. Ft. of Crack Retrofitted
	Average Caulking Weatherstripping	0.639	Enter Lin. Ft. of Crack Retrofitted
	Piping/Plumbing/Wiring Penetrations - Sealing	10.900	Enter Number of Penetrations Retrofitted
Caulking	Window Framing, Masonry - Caulking	1.364	Enter Sq. Ft. of Windows Retrofitted
	Window Framing, Wood - Caulking	0.382	Enter Sq. Ft. of Windows Retrofitted
	Door Frame, Masonry - Caulking	1.018	Enter Sq. Ft. of Doors Retrofitted
	Door Frame, Wood - Caulking	0.364	Enter Sq. Ft. of Doors Retrofitted
	Average Window/Door - Caulking	0.689	Enter Lin. Ft. of Crack Retrofitted
Avg Caulking / Weather Stripping	Average Window/Door Caulking / Weather Stripping	0.664	Enter Lin. Ft. of Crack Retrofitted
Gasket	Electrical Outlets - Gasket	6.491	Enter Number of Outlets Retrofitted

OR if blower door or total building pressurization measurements have been conducted, by determining the CFM infiltration differential between the existing and efficient building air infiltration rates:

$$= \text{CFM50}_{\text{existing}} - \text{CFM50}_{\text{efficient}}$$

Where:

$\text{CFM50}_{\text{existing}}$  = CFM of Infiltration measured by blower door or by total building pressurization test before air sealing, adjusting measured CFM to equivalent CFM at 50 pascals indoor/outdoor pressure differential<sup>1827</sup>

$\text{CFM50}_{\text{efficient}}$  = Infiltration as measured by blower door or total building pressurization test after air sealing, adjusted to equivalent CFM at 50 pascals pressure differential

$\text{CDD55/yr}$  = Annual cooling degree days at 55F base for the climate zone of the location of the building as deemed in the table below<sup>1828</sup>

Climate Zone	Cooling Degree Days: CDD55/yr
1 (Rockford)	2284
2 (Chicago)	2494
3 (Springfield)	2761
4 (Belleville)	3480
5 (Marion/Murphysboro)	3186

24 = 24 hours per day

<sup>1827</sup> 50 Pascals has been established in TRM XXX as the standard building pressure differential for determining average annual infiltration rates; 50 Pascals differential is equivalent to a wind pressure from approximately 10 mph.

<sup>1828</sup> National Centers for Environmental Information (NCEI) Annual Normals, from 2006 - 2020, calculated with a base temp of 55°F

1000 = Conversion of watts to kW

$\eta_{Cool}$  = Efficiency of cooling system. Actual, if possible. Alternatively, use IECC 2012 if equipment type is known, or as deemed from table below<sup>1829</sup>

Space Cooling / Heating Source	Deemed Cooling EER	Deemed Cooling SEER
No Cooling	N/A	N/A
Unknown Cooling Source	11	13

%Cool = Percentage of the building that is cooled

HDD55/yr = Annual heating degree days at 60F base for the climate zone of the building, as deemed in the table below<sup>1830</sup>

Climate Zone	Heating Degree Days: HDD55/yr
1 (Rockford)	4171
2 (Chicago)	3760
3 (Springfield)	3296
4 (Belleville)	2351
5 (Marion/Murphysboro)	2499

$\eta_{Heat}$  = Efficiency of heating system. Actual, if possible. Alternatively, as deemed from table below:

System Type	Cooling Capacity of Equipment	Age of Equipment	HSPF Estimate	$\eta$ (Effective COP Estimate) (HSPF/3.413)
Heat Pump <sup>1831</sup>	All	Before 2009	6.8	2.0
	< 65,000 Btu/h	2009 - 2017	7.7	2.3
		2017 on	8.2	2.40
	$\geq 65,000$ Btu/h and < 135,000 Btu/h	2010 on	11.3	3.3
	$\geq 135,000$ Btu/h and < 240,000 Btu/h	2010 on	10.9	3.2
$\geq 240,000$ Btu/h and < 760,000 Btu/h	2010 on	10.9	10.9	3.2
Resistance	N/A	N/A	N/A	1
Fossil Fuel Furnace or Boiler	N/A	N/A	N/A	0.8 Thermal Efficiency

3,412 = Number of BTUs per kWh

<sup>1829</sup> Simplified version of IECC 2012 as a conservative estimate of what is existing.

<sup>1830</sup> National Centers for Environmental Information (NCEI) Annual Normals, from 2006 - 2020, calculated with a base temp of 55°F

<sup>1831</sup> Minimum heating efficiency standards for heat pumps are sourced from the Code of Federal Standards for Small and Large Commercial Package Air Conditioning and Heating Equipment (Air Cooled), 10 CFR 431.97 with compliance dates of June 16, 2008; January 1, 2010; January 1, 2017; and January 1, 2018. As the first federal appliance standards for heating efficiency for commercial heat pumps went into effect in June 2008, assuming efficiency standards equivalent to residential heat pumps prior to that date.

- %ElectricHeat = % of building heated by electricity
- Fe = Furnace Fan energy consumption as a percentage of annual fuel consumption  
= 7.7%<sup>1832</sup>
- 29.3 = kWh per therm (= 100,000 BTU/Therm / 3,412 BTU/kWh )

For example, assuming air conditioned and electric resistance heated building with 10 IEER equipment in Rockford: Infiltration\_CFM\_Saved = 272.8; CDD55/yr = 2,284; ηCool = 10.0; %Cool = 100%, HDD55/yr = 4,171; ηHeat = 1.0; %ElectricHeat = 100%, then

$$\begin{aligned} \Delta\text{kWh\_Cooling} &= 1.08 * 272.8 * 2284 * 24 / 1000 / 10 * 100\% \\ &= 1615 \text{ kWh of cooling energy saved} \end{aligned}$$

$$\begin{aligned} \Delta\text{kWh\_Heating} &= 1.08 * 272.8 * 4171 * 24 / 1.0 / 3,412 * 100\% \\ &= 8644 \text{ kWh of cooling energy saved} \end{aligned}$$

$$\begin{aligned} \Delta\text{kWh} &= \Delta\text{kWh\_cooling} + \Delta\text{kWh\_heatingElectric} + \Delta\text{kWh\_heatingFurnace} \\ &= 1615 + 8644 + 0 \\ &= 10259 \text{ kWh} \end{aligned}$$

#### SUMMER COINCIDENT PEAK DEMAND SAVINGS

$$\Delta\text{kW} = \Delta\text{kWh\_cooling} / \text{EFLH}_{\text{cooling}} * \text{CF}$$

Where:

- ΔkWh\_cooling = Sum of kWh saved from cooling from above calculations
- EFLH<sub>cooling</sub> = Equivalent Full Load Hours for cooling in Existing Buildings are provided in section 4.4 HVAC End Use
- CF<sub>SSP</sub> = Summer System Peak Coincidence Factor for Commercial cooling (during system peak hour)  
= 91.3%<sup>1833</sup>
- CF<sub>PJM</sub> = PJM Summer Peak Coincidence Factor for Commercial cooling (average during peak period)  
= 47.8%<sup>1834</sup>

<sup>1832</sup> Fe is estimated using TRM models for the three most popular building types for programmable thermostats: low-rise office (10.2%), sit-down restaurant (8.6%), and retail – strip mall (4.4%). 7.7% reflects the average Fe of the three building types. See “Fan Energy Factor Example Calculation 2021-06-23.xlsx” for reference.

<sup>1833</sup> Based on analysis of Itron eShape data for Missouri, calibrated to Illinois loads, supplied by Ameren. The AC load during the utility’s peak hour is divided by the maximum AC load during the year.

<sup>1834</sup>Based on analysis of Itron eShape data for Missouri, calibrated to Illinois loads, supplied by Ameren. The average AC load over the PJM peak period (1-5pm, M-F, June through August) is divided by the maximum AC load during the year.



For example, for an Elementary School in Rockford with air conditioning as defined earlier in this section; assuming:  $\Delta kWh_{cooling} = 1615$ ;  $EFLH = 834$ ;  $CF_{SSP} = 0.913$ , then

$$\begin{aligned} \Delta kW &= 1615 / 834 * 0.913 \\ &= 1.77 \text{ kW} \end{aligned}$$

**FOSSIL FUEL SAVINGS**

If Fossil Fuel heating:

$$\Delta \text{Therms} = 1.08 * \text{Infiltration\_CFM\_Saved} * \text{HDD55/yr} * 24 / \eta_{\text{Heat}} / 100,000 * \% \text{FossilHeat}$$

Where:

- $\eta_{\text{Heat}}$  = as defined previously
- 100,000 = BTUs per therm
- $\% \text{FossilHeat}$  = % of building heated by fossil fuel

**For Example**, assuming for Rockford with unknown natural gas heat:  $\text{Infiltration\_CFM\_Saved} = 272.8$ ;  $\text{HDD55/yr} = 2284$ ;  $\eta_{\text{Heat}} = 0.80$ ;  $\% \text{GasHeat} = 100\%$ , then

$$\begin{aligned} \Delta \text{Therms} &= 1.08 * 272.8 * 2284 * 24 / 0.80 / 100000 * 100\% \\ &= 202 \text{ Therms} \end{aligned}$$

**WATER AND OTHER NON-ENERGY IMPACT DESCRIPTIONS AND CALCULATION**

N/A

**DEEMED O&M COST ADJUSTMENT CALCULATION**

N/A

**MEASURE CODE: CI-MS-C-AIR-V03-240101**

**REVIEW DEADLINE: 1/1/2026**

## 4.8.28 High Speed Overhead Doors

### DESCRIPTION

This measure applies to buildings with exterior entryways that utilize overhead doors between heated and/or air conditioned spaces and the outdoors that see a high amount of traffic on a daily basis. High speed doors for refrigerated spaces are covered in section 4.6.10 of the TRM. All other high speed door applications, such as conventional foot-traffic entryways, require custom analysis.

The use of overhead doors within exterior entryways during the heating season leads to the exfiltration of warm air from the upper portion of the door opening and the infiltration of colder air from the lower portion of the door opening. This results in increased heating energy use to compensate for heat losses every time a door is opened. By reducing the time it takes for the door to open and close, high speed doors can also enhance the physical comfort of employees or customers near the entryway as there will be reduced temperature fluctuations when the door is opened and closed. In addition, in some cases excess heating capacity may be installed in buildings to meet this larger heating load. The addition of high speed doors to exterior entryways that currently utilize standard overhead doors will result in energy savings and enhanced personal comfort, and also possibly in reduced equipment sizing and associated costs.

The primary markets for this measure are commercial and industrial facilities with overhead doors in exterior entryways, including but not limited to the following building types: manufacturing, warehouse (non-refrigerated), vehicle maintenance facilities, and enclosed/heated commercial or multifamily parking garages.

This measure was developed to be applicable to the following program types: NC, RF. If applied to other program types, the measure savings should be verified.

### DEFINITION OF EFFICIENT EQUIPMENT

To qualify for this measure the installed equipment must be a High Speed Door installed at a loading dock or drive-in door for a heated and/or cooled warehouse, manufacturing, service garage, or similar space. Heating can be gas fired or electric heat pump. Doors which have a refrigerated space on the interior should use measure 4.6.10 for High Speed Rollup Doors. Doors separating interior spaces with different temperature setpoints on either side are not eligible.

High speed doors must have a minimum opening speed of 32 inches per second and a minimum closing speed of 24 inches per second<sup>1835</sup>.

### DEFINITION OF BASELINE EQUIPMENT

The baseline equipment is a standard overhead door, which is generally estimated to have an opening and closing speed of around 8 inches per second<sup>1836</sup>. The doorway should not have any type of existing open-doorway protection such as strip curtains or air curtains.

### DEEMED LIFETIME OF EFFICIENT EQUIPMENT

The expected measure life is assumed to be 16 years.<sup>1837</sup>

### DEEMED MEASURE COST

The incremental measure cost is \$105/sqft.<sup>1838</sup>

---

<sup>1835</sup> DASMA Standard 403-2020, "Specification for High Speed Doors and Grilles", DASMA Standard (2020): Section 2.6.

<sup>1836</sup> Wendt, Jeff, "When a High-Speed Door is More Energy Efficient", Door & Access Systems Magazine – Tech Tips. September 2014.

<sup>1837</sup> Assumed same measure life as high speed rollup doors for refrigerated spaces (4.6.10); As recommended in Navigant 'ComEd Effective Useful Life Research Report', May 2018.

<sup>1838</sup> The incremental cost is derived from analysis of a set of PG NSG custom project data, and based on equipment quotes in 2021.

**LOADSHAPE**

Heating Season: If electric heating, use Commercial Electric Heating Loadshape: C04. Otherwise, N/A

Cooling Season: Commercial Cooling Loadshape C03. Or, if applicable, use Commercial Electric Heating and Cooling Loadshape C05.

**COINCIDENCE FACTOR**

$$CF_{SSP} = \text{Summer System Peak Coincidence Factor for Commercial cooling (during system peak hour)}$$

$$= 91.3\%^{1839}$$

$$CF_{PJM} = \text{PJM Summer Peak Coincidence Factor for Commercial cooling (average during peak period)}$$

$$= 47.8\%^{1840}$$

---



---

**Algorithm**

---



---

**CALCULATION OF ENERGY SAVINGS**

The following formulas provide a methodology for estimating cooling load (kWh) and heating load (therm) savings associated with the installation of a high speed overhead door on exterior entryways such as a single door or loading bay. This algorithm is based on the assumption that savings are directly related to the difference in cooling or heating losses due to infiltration or exfiltration through an entryway before and after the installation of the high speed door. Energy savings are assumed to be the result of a reduction of natural infiltration effects due to wind and thermal forces and follow the calculation methodology outlined by the ASHRAE Handbook.<sup>1841</sup>

This algorithm allows either actual inputs or provides estimates if actual data is not available. All weather dependent values are derived from TMY3 data for the closest weather station to those locations defined elsewhere in the Illinois TRM (which are based on 30 year climate normals). If TMY3 weather station data was not available for the data used in the Illinois TRM, the next closest weather station was used. It is assumed that weather variations are negligible between the weather stations located within the same region. This approach was followed as the high speed door algorithm has a number of weather dependent variables, which are all calculated in relation to the heating season or cooling season as defined by the balance point temperature deemed appropriate for the facility. All weather dependent data is based on TMY3 data and is listed in tables by both climate zone and balance point temperature, which is then normalized to the Illinois TRM climate zoned HDD/CDD definitions unless otherwise noted.

**ELECTRIC ENERGY SAVINGS**

$$\Delta kWh_{cooling} = (Q / EER) * (t_{standard} - t_{fast}) * CD$$

$$\Delta kWh_{HPheating} = (Q / HSPF) * (t_{standard} - t_{fast}) * HD$$

Where:

Q = rate of total heat transfer through the open entryway (kBtu/hr)  
(see calculation in ‘Heat Transfer Through Open Entryway’ section below)

EER = energy efficiency ratio of the cooling equipment (kBtu/kWh)  
= Actual. If unknown, use the table C403.2.3(2) in IECC 2012 (or IECC 2018 if through new construction) to assume values based on code estimates.

---

<sup>1839</sup> Based on analysis of Itron eShape data for Missouri, calibrated to Illinois loads, supplied by Ameren. The AC load during the utility’s peak hour is divided by the maximum AC load during the year.

<sup>1840</sup> Based on analysis of Itron eShape data for Missouri, calibrated to Illinois loads, supplied by Ameren. The average AC load over the PJM peak period (1-5pm, M-F, June through August) is divided by the maximum AC load during the year.

<sup>1841</sup> ASHRAE, “Ventilation and Infiltration,” in 2013 ASHRAE Handbook – Fundamentals (2013): Ch 16.1 - 16.37.

Note IECC 2018 became effective July 1, 2019 and is the baseline for all New Construction permits from that date.

$t_{\text{standard}}$  = average hours per day the standard speed door is open (hr/day)

(see calculation in 'Time door is open' section below)

$t_{\text{fast}}$  = average hours per day the high speed door is open (hr/day)

(see calculation in 'Time door is open' section below)

CD = cooling days per year, total days in year above balance point temperature (day)

= use table below to select the best value for location:<sup>1842</sup>

Climate Zone -Weather Station/City	CD (Balance Point Temperature)				
	45 °F	50 °F	55 °F	60 °F	65 °F
1 - Rockford AP / Rockford	194	168	148	124	97
2 - Chicago O'Hare AP / Chicago	194	173	153	127	95
3 - Springfield #2 / Springfield	214	194	174	148	114
4 - Belleville SIU RSCH / Belleville	258	229	208	174	138
5 - Carbondale Southern IL AP / Marion	222	201	181	158	130

HSPF = Heating System Performance Factor of heat pump equipment

= Actual. If unknown, use the table C403.2.3(2) in IECC 2012 (or IECC 2018 if through new construction) to assume values based on code estimates.

Note IECC 2018 became effective July 1, 2019 and is the baseline for all New Construction permits from that date.

HD = heating days per year, total days in year above balance point temperature (day)

= use table below to select an appropriate value:<sup>1843</sup>

Climate Zone Weather Station/City	HD				
	45 °F	50 °F	55 °F	60 °F	65 °F
1 - Rockford AP / Rockford	142	160	183	204	228
2 - Chicago O'Hare AP / Chicago	150	166	192	219	253
3 - Springfield #2 / Springfield	125	142	167	194	230
4 - Belleville SIU RSCH / Belleville	101	115	134	156	180
5 - Carbondale Southern IL AP / Marion	103	123	148	174	205

### Time Door is Open

$t_{\text{standard}}$  = CyclesPerDay \* [ $H_d * 12 * (1 / \text{Speed}_{\text{open\_standard}} + 1 / \text{Speed}_{\text{close\_standard}})$ ] / 3600

$t_{\text{fast}}$  = CyclesPerDay \* [ $H_d * 12 * (1 / \text{Speed}_{\text{open\_fast}} + 1 / \text{Speed}_{\text{close\_fast}})$ ] / 3600

<sup>1842</sup> National Solar Radiation Data Base – 1991 – 2005 Update: Typical Meteorological Year 3, NREL. Note that cooling days (CD) are calculated by first determining its value from the TMY3 data associated with the appropriate weather station as defined by and used elsewhere in the Illinois TRM. Using the TMY3 outdoor air dry bulb hourly data, the annual hours are totaled for every hour that the outdoor air dry bulb temperature is above a designated zero heat loss balance point temperature or base temperature for cooling. For commercial and industrial (C&I) buildings, a base temperature for heating of 55 oF is designated in the Illinois TRM, but building specific base temperatures are recommended for large C&I projects. Additionally, the TRM uses a 30-year normal data for degree-days while the CD calculation was based on TMY3 data; in order to account for this, calculations of CD were also normalized by the ratio of CDD to align the calculated values more closely with the TRM.

<sup>1843</sup> Note that Heating Days (HD) are calculated following the same approach outlined in the Cooling Days section.

Where:

- CyclesPerDay = the number of door opening and closing cycles per day  
= Actual. If unknown, use 75<sup>1844</sup> or for parking garages calculate based on the number of parking spaces<sup>1845</sup>.
- H<sub>d</sub> = the height of the doorway (ft)  
= user input
- 12 = unit conversion from feet to inches
- Speed<sub>open</sub> = the speed (inches/second) at which the door opens  
= Actual. If unknown, use 32 inches/second for high speed<sup>1846</sup>, use 8 inches/second for standard speed<sup>1847</sup>
- Speed<sub>close</sub> = the speed (inches/second) at which the door closes  
= Actual. If unknown, use 24 inches/second for high speed<sup>1848</sup>, = 8 inches/second for standard speed<sup>1849</sup>
- 3600 = unit conversion from seconds to hours

**Heat Transfer Through Open Entryway (Cooling Season)**

$$Q = 4.5 * CFM_{tot} * (h_{oc} - h_{ic}) / (1,000 \text{ Btu/kBtu})$$

Where:

- 4.5 = unit conversion factor with density of air: 60 min/hr \* 0.075 lbm/ft<sup>3</sup> (lb\*min/(ft\*hr))
- CFM<sub>tot</sub> = Total air flow through entryway (cfm), see calculation below
- h<sub>oc</sub> = average enthalpy of outside air during the cooling season (Btu/lb)  
= use the below table to determine the approximate outdoor air enthalpy associated with an indoor temperature setpoint and climate zone.<sup>1850</sup>

Climate Zone -Weather Station/City	h <sub>oc</sub>		
	67 °F	72 °F	77 °F
1 - Rockford AP / Rockford	31.6	33.0	35.3
2 - Chicago O'Hare AP / Chicago	32.0	33.6	35.4
3 - Springfield #2 / Springfield	32.9	34.6	36.6
4 - Belleville SIU RSCH / Belleville	33.5	35.0	36.4
5 - Carbondale Southern IL AP / Marion	34.6	36.2	37.7

<sup>1844</sup> Wendt, Jeff, "When a High-Speed Door is More Energy Efficient", Door & Access Systems Magazine – Tech Tips. Sept. 2014.

<sup>1845</sup> ASHRAE, "Enclosed Vehicular Facilities – Parking Garages," in 2019 ASHRAE Handbook – HVAC Applications (2019): p. 16.18 to 16.20. Number of cars operating is 3-5% (use 4% as average) per hour of the total vehicle capacity, making openings per day = 4% \* number of parking spaces \* 24 hours per day \* 2 (car will enter and leave once per day).

<sup>1846</sup> DASMA Standard 403-2020, "Specification for High Speed Doors and Grilles", DASMA Standard (2020): Section 2.6.

<sup>1847</sup> Wendt, Jeff, "When a High-Speed Door is More Energy Efficient", Door & Access Systems Magazine – Tech Tips. Sept. 2014.

<sup>1848</sup> DASMA Standard 403-2020, "Specification for High Speed Doors and Grilles", DASMA Standard (2020): Section 2.6.

<sup>1849</sup> Wendt, Jeff, "When a High-Speed Door is More Energy Efficient", Door & Access Systems Magazine – Tech Tips. Sept. 2014.

<sup>1850</sup> Average enthalpies were estimated following ASHRAE guidelines for perfect gas relationships for dry air associated with hourly TMY3 data. Enthalpies were then averaged for all values associated with a dry-bulb outdoor air temperature that exceeded the indoor air temperature setpoint. Other enthalpy values may be interpolated for indoor air temperature setpoints not represented in the table. Note that while outdoor air enthalpies increase with higher temperature setpoints, the change in enthalpy from indoor to outdoor will decrease.

$h_{ic}$  = average enthalpy of indoor air, cooling season (Btu/lb)

= use the below table to determine the approximate indoor air enthalpy associated with an indoor temperature setpoint in indoor relative humidity.

Relative Humidity (%)	$h_{ic}$		
	67 °F	72 °F	77 °F
60	25.5	28.5	31.8
50	23.9	26.6	29.5
40	22.3	24.7	27.3

= an estimate 26.6 Btu/lb associated with the 72 °F and 50% indoor relative humidity case can be used as an approximation if no other data is available. For other indoor temperature setpoints and RH, enthalpies may be interpolated.

The total airflow through the entryway,  $CFM_{tot}$ , includes both infiltration due to wind as well as thermal forces, as follows:

$$CFM_{tot} = \text{sqrt} [ (CFM_w)^2 + (CFM_t)^2 ]$$

Where:

$CFM_w$  = Infiltration due to the wind (cfm)

$CFM_t$  = Infiltration due to thermal forces (cfm)

The infiltration due to the wind is calculated as follows:

$$CFM_w = (v_{wc} * C_{wc}) * C_v * A_d * (88 \text{ fpm/mph})$$

Where:

$v_{wc}$  = average wind speed during the cooling season based on entryway orientation (mph)

= use the below table to for the wind speed effects based on climate zone and entryway orientation:<sup>1851</sup>

Climate Zone -Weather Station /City	Entryway Orientation				
	N	E	S	W	Unknown (average)
1 - Rockford AP / Rockford	4.2	4.1	4.7	4.8	4.5
2 - Chicago O'Hare AP / Chicago	4.7	4.5	5.4	4.6	4.8
3 - Springfield #2 / Springfield	4.1	3.7	6.0	5.0	4.7
4 - Belleville SIU RSCH / Belleville	3.3	2.7	3.8	4.2	3.5
5 - Carbondale Southern IL AP / Marion	3.1	2.9	4.4	3.8	3.6

<sup>1851</sup> Average wind speeds are calculated based on the TMY3 wind speed data. Because this data is collected at an altitude of 33 ft, wind speed is approximated for a 5 ft level based on ASHRAE Handbook guidelines using the urban/suburban parameters for adjusting wind speed based on altitude (Layer thickness (ft)  $\delta = 1200$ , Exponent  $a = 0.22$ ). ASHRAE, "Airflow Around Buildings," in 2013 ASHRAE Handbook – Fundamentals (2013): p 24.3.

$C_{wc}$  = wind speed correction factor due to wind direction in cooling season (%)

= because wind direction is not constant, a wind speed correction factor is used to adjust for the amount of time during the cooling season prevailing winds can be expected to impact the entryway. Use the following table to determine the correct wind speed correction factor for cooling applications.

Climate Zone -Weather Station/City	Entryway Orientation				
	N	E	S	W	Unknown (Average)
1 - Rockford AP / Rockford	0.18	0.13	0.30	0.31	0.23
2 - Chicago O'Hare AP / Chicago	0.18	0.17	0.36	0.26	0.24
3 - Springfield #2 / Springfield	0.17	0.12	0.46	0.21	0.24
4 - Belleville SIU RSCH / Belleville	0.21	0.15	0.35	0.16	0.22
5 - Carbondale Southern IL AP / Marion	0.18	0.15	0.37	0.11	0.20

Note that correction factors do not add up to 1 (100%). This is attributed to periods of calm winds.

$C_v$  = effectiveness of openings,  
= 0.3, assumes diagonal wind<sup>1852</sup>

$A_d$  = area of the doorway (ft<sup>2</sup>)  
= user defined

The infiltration due to thermal forces is calculated as follows:

$$CFM_t = A_d * C_{dc} * (60 \text{ sec/min}) * \text{sqrt}[2 * g * H_d/2 * (T_{oc} - T_{ic}) / (459.7 + T_{oc})]$$

Where:

$C_{dc}$  = the discharge coefficient during the cooling season<sup>1853</sup>  
=  $0.4 + 0.0025 * |T_{ic} - T_{oc}|$

Note, values for  $C_{dc}$  show little variation due to balance point temperature, indoor air temperature, and climate zone. As such, if estimating results, the Illinois average value of 0.42 at indoor air temp of 72°F may be used as a simplification.

$g$  = acceleration due to gravity  
= 32.2 ft/sec<sup>2</sup>

$T_{ic}$  = Average indoor air temperature during cooling season  
= User input, can assume indoor cooling temperature set-point

$T_{oc}$  = Average outdoor temp during cooling season (°F)  
= the average outdoor temperature is dependent on the CD period and zone. As such, the following table may be used for average outdoor temperature during the cooling period:<sup>1854</sup>

<sup>1852</sup> ASHRAE, "Ventilation and Infiltration," in 2013 ASHRAE Handbook – Fundamentals (2013): p 16.13

<sup>1853</sup> ASHRAE, "Ventilation and Infiltration," in 2013 ASHRAE Handbook – Fundamentals (2013): p 16.13.

<sup>1854</sup> Based on binned data from TMY3 & adjusted bracketed thermostat setpoint temperatures. Interpolate other values as needed.

Climate Zone Weather Station/City	T <sub>oc</sub>				
	62 °F	67 °F	72 °F	77 °F	82 °F
1 - Rockford AP / Rockford	72.9	76.0	79.2	82.5	85.5
2 - Chicago O'Hare AP / Chicago	72.9	76.0	79.4	82.8	85.5
3 - Springfield #2 / Springfield	73.7	76.7	79.9	83.4	86.4
4 - Belleville SIU RSCH / Belleville	74.9	77.7	81.0	84.3	86.9
5 - Carbondale Southern IL AP / Marion	75.1	77.7	80.9	84.7	87.4

459.7 = conversion factor from °F to °R

= calculation requires absolute temperature for values not calculated as a difference of temperatures.

**SUMMER COINCIDENT PEAK DEMAND SAVINGS**

$$\Delta kW = (\Delta kWh_{cooling} / (CD * 24)) * CF$$

Where:

CF<sub>SSP</sub> = Summer System Peak Coincidence Factor for Commercial cooling (during system peak hour)  
 = 91.3%<sup>1855</sup>

CF<sub>PJM</sub> = PJM Summer Peak Coincidence Factor for Commercial cooling (average during peak period)  
 = 47.8%<sup>1856</sup>

**NATURAL GAS SAVINGS**

Natural gas savings, Δtherms, associated with reduced infiltration through an entryway during the heating season are calculated by determining the difference between heat loss through the entryway before and after the installation of the high speed overhead door.

$$\Delta therm = Q * (t_{standard} - t_{fast}) * HD / \eta$$

Where:

Q = rate of sensible heat transfer through the open entryway, before air curtain (therm/hr)

t<sub>standard</sub> = average hours per day the standard speed door is open (hr/day)  
 (see calculation in 'Time door is open' heading of Electric Energy Savings section)

t<sub>fast</sub> = average hours per day the high speed door is open (hr/day)  
 (see calculation in 'Time door is open' heading of Electric Energy Savings section)

HD = heating days per year, total days in year above balance point temperature (day)  
 = use table below to select an appropriate value:<sup>1857</sup>

Climate Zone - Weather Station/City	HD				
	45 °F	50 °F	55 °F	60 °F	65 °F
1 - Rockford AP / Rockford	142	160	183	204	228

<sup>1855</sup> Based on analysis of Itron eShape data for Missouri, calibrated to Illinois loads, supplied by Ameren. The AC load during the utility's peak hour is divided by the maximum AC load during the year.

<sup>1856</sup> Based on analysis of Itron eShape data for Missouri, calibrated to Illinois loads, supplied by Ameren. The average AC load over the PJM peak period (1-5pm, M-F, June through August) is divided by the maximum AC load during the year

<sup>1857</sup> Note that Heating Days (HD) are calculated following the same approach outlined in the Cooling Days section.



Climate Zone - Weather Station/City	HD				
	45 °F	50 °F	55 °F	60 °F	65 °F
2 - Chicago O'Hare AP / Chicago	150	166	192	219	253
3 - Springfield #2 / Springfield	125	142	167	194	230
4 - Belleville SIU RSCH / Belleville	101	115	134	156	180
5 - Carbondale Southern IL AP / Marion	103	123	148	174	205

$\eta$  = efficiency of heating equipment  
 = Actual. If unknown, assume 0.8

**Heat Transfer Through Open Entryway (Heating Season)**

$$Q = 1.08 * CFM_{tot} * (T_{ih} - T_{oh}) / (100,000 \text{ Btu/therm})$$

Where:

- 1.08 = sensible heat transfer coefficient: specific heat of air and unit conversions, Btu/(hr\*°F\*cfm)
- CFM<sub>tot</sub> = Total air flow through entryway (cfm)
- T<sub>ih</sub> = Average indoor air temperature during heating season  
 = User input, can assume indoor heating temperature set-point
- T<sub>oh</sub> = Average outdoor temp during heating season (°F)  
 = use table below, based on binned data from TMY3 & balance point temperature:

Climate Zone -Weather Station/City	Avg Outdoor Air Temp - Heating Season				
	45 °F	50 °F	55 °F	60 °F	65 °F
1 - Rockford AP / Rockford	26.3	28.8	31.6	34.2	37.3
2 - Chicago O'Hare AP / Chicago	29.4	31.2	34.0	36.8	40.3
3 - Springfield #2 / Springfield	29.4	31.5	34.6	37.7	41.6
4 - Belleville SIU RSCH / Belleville	31.7	33.6	36.2	39.2	42.3
5 - Carbondale Southern IL AP / Marion	32.5	34.9	37.8	40.7	44.0

The total airflow through the entryway, CFM<sub>tot</sub>, includes both infiltration due to wind as well as thermal forces, as follows:

$$CFM_{tot} = \text{sqrt}[(CFM_w)^2 + (CFM_t^2)]$$

Where:

- CFM<sub>w</sub> = Infiltration due to the wind (cfm)
- CFM<sub>t</sub> = Infiltration due to thermal forces (cfm)

The infiltration due to the wind is calculated as follows:

$$CFM_w = (v_{wh} * C_{wh}) * C_v * A_d * (88 \text{ fpm/mpH})$$

Where:

- v<sub>wh</sub> = average wind speed during the heating season (mph)  
 = similar to cooling season wind speed assumptions, use the following table to determined average wind speed based on entryway orientation:

Climate Zone -Weather Station/ City	Entryway Orientation			
	N	E	S	W

	Entryway Orientation			
1 - Rockford AP / Rockford	5.0	4.6	4.9	5.6
2 - Chicago O'Hare AP / Chicago	5.5	5.2	4.9	5.1
3 - Springfield #2 / Springfield	5.0	4.9	5.3	5.1
4 - Belleville SIU RSCH / Belleville	4.3	3.4	3.5	5.3
5 - Carbondale Southern IL AP / Marion	4.6	3.2	4.2	4.4

$C_{wh}$  = wind speed correction factor due to wind direction in heating season, (%)

= because wind direction is not constant, a wind speed correction factor is used to adjust for the amount of time during the heating season prevailing winds can be expected to impact the entryway. Use the following table to determine the correct wind speed correction factor for the heating applications.

	Entryway Orientation			
Climate Zone -Weather Station/ City	N	E	S	W
1 - Rockford AP / Rockford	0.18	0.13	0.30	0.31
2 - Chicago O'Hare AP / Chicago	0.21	0.10	0.26	0.39
3 - Springfield #2 / Springfield	0.21	0.14	0.27	0.34
4 - Belleville SIU RSCH / Belleville	0.31	0.15	0.22	0.29
5 - Carbondale Southern IL AP / Marion	0.31	0.11	0.27	0.18

Note that correction factors do not add up to 1 (100%). This is attributed to periods of calm winds.

$C_v$  = effectiveness of openings,

= 0.3, assumes diagonal wind<sup>1858</sup>

$A_d$  = area of the doorway (ft<sup>2</sup>)

= user input

The infiltration due to thermal forces is calculated as follows:

$$CFM_t = A_d * C_{dh} * (60 \text{ sec/min}) * \text{sqrt}[2 * g * H/2 * (T_{ih} - T_{oh}) / (459.7 + T_{ih})]$$

Where:

$C_{dh}$  = the discharge coefficient during the heating season

$$= 0.4 + 0.0025 * |T_{ih} - T_{oh}|$$

Note, values for  $C_{dh}$  show little variation due to balance point temperature, indoor air temperature, and climate zone. As such, if estimating results, the Illinois average value of 0.49 at indoor air temp of 72°F may be used as a simplification.

$g$  = acceleration due to gravity

$$= 32.2 \text{ ft/sec}^2$$

$H$  = the height of the entryway (ft)

= user defined

## WATER AND OTHER NON-ENERGY IMPACT DESCRIPTIONS AND CALCULATION

N/A

<sup>1858</sup> ASHRAE, "Ventilation and Infiltration," in 2013 ASHRAE Handbook – Fundamentals (2013): p 16.13

**DEEMED O&M COST ADJUSTMENT CALCULATION**

Manufacturers suggest annual inspection and maintenance (such as patching tears) of high speed doors. At a minimum, greasing of fittings and oil top-off should be carried out annually. This is estimated at a cost of \$150 per year.<sup>1859</sup>

**MEASURE CODE: CI-MSC-HSOD-V01-230101**

**REVIEW DEADLINE: 1/1/2026**

---

<sup>1859</sup>Assumes approximately 1 hour of maintenance, based on manufacturer product spec sheets.

## 4.8.29 Dock Door Seals and Shelter

### DESCRIPTION

This measure applies to buildings with exterior doors that serve as loading docks.

Overhead dock doors allow for loading and unloading of trucks. When the truck backs into the dock bumpers, a gap is created between the truck and the dock door that allows the infiltration or exfiltration of air in the upper, lower, and side portions. The infiltration/exfiltration of cold and warm air during the heating and cooling seasons increases the energy load of the building. Dock door seals are foam panels that are mounted outside of the dock door. Dock shelters are structures that form an enclosure around the perimeter of the trailer and are mounted outside of the dock door. The addition of dock door seals and shelters forms a tight seal between the truck and the door that prevents air infiltration/exfiltration and results in energy savings and enhanced personal comfort. Dock door seals and shelters also prevent the passing of rain droplets, snow, dust, insects, and other airborne particles.

This measure was developed to be applicable to the following program types: RF. If applied to other program types, the measure savings should be verified.

### DEFINITION OF EFFICIENT EQUIPMENT

Dock doors with compression seals or shelters forming a tight seal around the top, bottom, and sides of the truck and installed following manufacturer guidelines to effectively reduce heat loss and air during truck loading and unloading.

### DEFINITION OF BASELINE EQUIPMENT

Dock doors with no seals or shelters installed to effectively reduce heat loss and air during truck loading and unloading.

### DEEMED LIFETIME OF EFFICIENT EQUIPMENT

The expected measure life is assumed to be 15 years<sup>1860</sup>.

### DEEMED MEASURE COST

The capital cost for dock door seals for exterior entryways is \$3,692<sup>1861</sup>.

### LOADSHAPE

Heating season: If electric heating, use Commercial Electric heating Loadshape, C04. Otherwise, N/A

Cooling seasons: Commercial Cooling Loadshape C03. Or, if applicable, use Commercial Electric Heating and Cooling Loadshape C05.

### COINCIDENCE FACTOR

CF<sub>SSP</sub> = Summer System Peak Coincidence Factor for Commercial cooling (during system peak hour)  
 = 91.3%<sup>1862</sup>

CF<sub>PJM</sub> = PJM Summer Peak Coincidence Factor for Commercial cooling (average during peak period)

---

<sup>1860</sup> California Statewide Codes and Standards Enhancement (CASE) Program. "Dock Seals – Final Report". California, November 2017.

<sup>1861</sup> Based on average project cost for dock door shelters incentivized under PG NSG Energy Efficiency programs between 2018 and 2020. Shelter average size is 85 square feet.

<sup>1862</sup> Based on analysis of Itron eShape data for Missouri, calibrated to Illinois loads, supplied by Ameren. The AC load during the utility's peak hour is divided by the maximum AC load during the year.

$$= 47.8\%^{1863}$$

---



---

**Algorithm**

---



---

**CALCULATION OF ENERGY SAVINGS**

The formulas follow the calculation methodology outlined by the ASHARE Handbook<sup>1864</sup> as stated in measure 4.4.33 Industrial Air Curtains.

**ELECTRIC ENERGY SAVINGS**

$$\Delta kWh_{cooling} = Q_{tbs} * t_{open} * CD / EER$$

$$\Delta kWh_{heating} = Q_{bs} * t_{open} * HD * (100 \text{ kBtu/therm}) / (HSPF * (3.412 \text{ kBtu/kWh}))$$

Where:

- $Q_{tbs}$  = rate of total heat transfer through the gap before dock door seal or shelter [kBtu/hr]
- $t_{open}$  = average hours per day that a truck is in the loading position and the truck dock door is open [hr/day]
  - = 8.39 hours<sup>1865</sup> or actual.
- CD = cooling days per year, total days in year above balance point temperature (day)
  - = use table below to select the best value for location, or 55°F if unknown:<sup>1866</sup>

Climate Zone - Weather Station/City	CD (Balance Point Temperature)				
	45°F	50°F	55°F	60°F	65°F
1 - Rockford AP / Rockford	194	168	148	124	97
2 - Chicago O'Hare AP / Chicago	194	173	153	127	95
3 - Springfield #2 / Springfield	214	194	174	148	114
4 - Belleville SIU RSCH / Belleville	258	229	208	174	138
5 - Carbondale Southern IL AP / Marion	222	201	181	158	130

- EER = energy efficiency ratio of the cooling equipment (kBtu/kWh)
  - = Actual. If unknown, use the table C403.2.3(2) in IECC 2012 (or IECC 2018 if through new construction) to assume values based on code estimates.
- HSPF = Heating System Performance Factor of heat pump equipment

<sup>1863</sup> Based on analysis of Itron eShape data for Missouri, calibrated to Illinois loads, supplied by Ameren. The average AC load over the PJM peak period (1-5pm, M-F, June through August) is divided by the maximum AC load during the year.

<sup>1864</sup> ASHRAE, "Ventilation and Infiltration," in 2013 ASHRAE Handbook – Fundamentals (2013): Ch 16.1 - 16.37.

<sup>1865</sup> Assumes 23-hour per day operation 5 days per week, with an average loading time of 45 minutes (including truck arrival and departure time) taken from: <https://www.novalocks.com/wp-content/uploads/Dock-Planning-Standards-Guide.pdf>. Average time between trucks estimated at 90 minutes taken from customer interviews. 5 day/7 days \* 23 hr/day / 90 minutes per truck event x 45 minutes door open time per truck event = 8.39 average hr/day, 7 days/week.

<sup>1866</sup> National Solar Radiation Data Base – 1991 – 2005 Update: Typical Meteorological Year 3, NREL.

Note that cooling days (CD) are calculated by first determining its value from the TMY3 data associated with the appropriate weather station as defined by and used elsewhere in the Illinois TRM. Using the TMY3 outdoor air-dry bulb hourly data, the annual hours are totaled for every hour that the outdoor air-dry bulb temperature is above a designated zero heat loss balance point temperature or base temperature for cooling. For commercial and industrial (C&I) buildings, a base temperature for heating of 55°F is designated in the Illinois TRM, but building specific base temperatures are recommended for large C&I projects. Additionally, the TRM uses a 30-year normal data for degree-days while the CD calculation was based on TMY3 data; in order to account for this, calculations of CD were also normalized by the ratio of CDD to align the calculated values more closely with the TRM.

= Actual. If unknown, use the table C403.2.3(2) in IECC 2012 (or IECC 2018 if through new construction) to assume values based on code estimates.

HD = heating days per year, total days in year above balance point temperature [day]

= use table below to select an appropriate value, or 55°F if unknown:<sup>1867</sup>

Climate Zone Weather Station/City	HD				
	45°F	50°F	55°F	60°F	65°F
1 - Rockford AP / Rockford	142	160	183	204	228
2 - Chicago O'Hare AP / Chicago	150	166	192	219	253
3 - Springfield #2 / Springfield	125	142	167	194	230
4 - Belleville SIU RSCH / Belleville	101	115	134	156	180
5 - Carbondale Southern IL AP / Marion	103	123	148	174	205

**Heat Transfer Through Open Dock Door Without Dock Door Seal or Shelter (during Cooling Season)**

$Q_{tbs} = 4.5 * CFM_{tot} * (h_{oc} - h_{ic}) / (1,000 \text{ Btu/kBtu})$

4.5 = unit conversion factor with density of air: 60min/hr \* 0.075 lbm/ft<sup>3</sup> (lbm \* min / (ft<sup>3</sup> \* hr))

CFM<sub>tot</sub> = total air flow through dock door (CFM)

h<sub>oc</sub> = average enthalpy of outside air during the cooling season (Btu/lb)

= use the below table to determine the approximate outdoor air enthalpy associated with an indoor temperature setpoint and climate zone, use 72°F if unknown.<sup>1868</sup>

Climate Zone -Weather Station/City	h <sub>oc</sub>		
	67°F	72°F	77°F
1 - Rockford AP / Rockford	31.6	33.0	35.3
2 - Chicago O'Hare AP / Chicago	32.0	33.6	35.4
3 - Springfield #2 / Springfield	32.9	34.6	36.6
4 - Belleville SIU RSCH / Belleville	33.5	35.0	36.4
5 - Carbondale Southern IL AP / Marion	34.6	36.2	37.7

h<sub>ic</sub> = average enthalpy of indoor air, cooling season (Btu/lb) point temperature

= use the below table to determine the approximate indoor air enthalpy associated with an indoor temperature setpoint in indoor relative humidity.

Relative Humidity (%)	h <sub>ic</sub>		
	67°F	72°F	77°F
60	25.5	28.5	31.8
50	23.9	26.6	29.5
40	22.3	24.7	27.3

= an estimate 26.6 Btu/lb associated with the 72°F and 50% indoor relative humidity case can be

<sup>1867</sup> Note that Heating Days (HD) are calculated following the same approach outlined in the Cooling Days section.

<sup>1868</sup> Average enthalpies were estimated following ASHRAE guidelines for perfect gas relationships for dry air associated with hourly TMY3 data. Enthalpies were then averaged for all values associated with a dry-bulb outdoor air temperature that exceeded the indoor air temperature setpoint. Other enthalpy values may be interpolated for indoor air temperature setpoints not represented in the table. Note that while outdoor air enthalpies increase with higher temperature setpoints, the change in enthalpy from indoor to outdoor will decrease.

used as an approximation if no other data is available. For other indoor temperature setpoints and RH, enthalpies may be interpolated.

The total airflow through the gaps, CFM<sub>tot</sub>, includes both infiltration due to wind as well as thermal forces, as follows:

$$CFM_{tot} = \text{sqrt}[(CFM_w)^2 + (CFM_t^2)]$$

Where:

CFM<sub>w</sub> = Infiltration due to the wind (cfm)

CFM<sub>t</sub> = Infiltration due to thermal forces (cfm)

The infiltration due to the wind is calculated as follows:

$$CFM_w = (v_{wc} * C_{wc}) * C_v * L_a * (88 \text{ fpm/mph})$$

Where:

v<sub>wc</sub> = average wind speed during the cooling season based on entryway orientation (mph)

= use the below table to for the wind speed effects based on climate zone and entryway orientation:<sup>1869</sup>

Climate Zone -Weather Station /City	Entryway Orientation				
	N	E	S	W	Unknown (average)
1 - Rockford AP / Rockford	4.2	4.1	4.7	4.8	4.5
2 - Chicago O'Hare AP / Chicago	4.7	4.5	5.4	4.6	4.8
3 - Springfield #2 / Springfield	4.1	3.7	6.0	5.0	4.7
4 - Belleville SIU RSCH / Belleville	3.3	2.7	3.8	4.2	3.5
5 - Carbondale Southern IL AP / Marion	3.1	2.9	4.4	3.8	3.6

C<sub>wc</sub> = wind speed correction factor due to wind direction in cooling season (%)

= because wind direction is not constant, a wind speed correction factor is used to adjust for the amount of time during the cooling season that prevailing winds can be expected to impact the entryway. Use the following table to determine the correct wind speed correction factor for cooling applications.

Climate Zone -Weather Station/City	Entryway Orientation				
	N	E	S	W	Unknown (Average)
1 - Rockford AP / Rockford	0.18	0.13	0.30	0.31	0.23
2 - Chicago O'Hare AP / Chicago	0.18	0.17	0.36	0.26	0.24
3 - Springfield #2 / Springfield	0.17	0.12	0.46	0.21	0.24
4 - Belleville SIU RSCH / Belleville	0.21	0.15	0.35	0.16	0.22
5 - Carbondale Southern IL AP / Marion	0.18	0.15	0.37	0.11	0.20

Note that correction factors do not add up to 1 (100%). This is attributed to periods of calm winds.

C<sub>v</sub> = effectiveness of openings,

<sup>1869</sup> Average wind speeds are calculated based on the TMY3 wind speed data. Because this data is collected at an altitude of 33 ft, wind speed is approximated for a 5 ft level based on ASHRAE Handbook guidelines using the urban/suburban parameters for adjusting wind speed based on altitude (Layer thickness (ft) δ = 1200, Exponent a = 0.22). ASHRAE, "Airflow Around Buildings," in 2013 ASHRAE Handbook – Fundamentals (2013): p 24.3.

= 0.3, assumes diagonal wind<sup>1870</sup>

$L_a$  = Leakage Area (gap) between doorway and truck (ft<sup>2</sup>)

= 16.8 feet<sup>1871</sup> or Actual.

The infiltration due to thermal forces is calculated as follows:

$$CFM_t = L_a * C_{dc} * (60 \text{ sec/min}) * \text{sqrt}[2 * g * H/2 * (T_{oc} - T_{ic}) / (459.7 + T_{oc})]$$

Where:

$C_{dc}$  = the discharge coefficient during the cooling season<sup>1872</sup>

$$= 0.4 + 0.0025 * |T_{ic} - T_{oc}|$$

= 0.42, Illinois average at indoor air temp of 72°F

Note, values for  $C_{dc}$  show little variation due to balance point temperature, indoor air temperature, and climate zone. As such, if estimating results, the Illinois average value may be used as a simplification.

$g$  = acceleration due to gravity

$$= 32.2 \text{ ft/sec}^2$$

$H$  = dock door height (ft)

= user input

$T_{ic}$  = Average indoor air temperature during cooling season

= User input, can assume indoor cooling temperature set-point

$T_{oc}$  = Average outdoor temp during cooling season (°F)

= the average outdoor temperature is dependent on the CD period and zone. As such, the following table may be used for average outdoor temperature during the cooling period.<sup>1873</sup>

Climate Zone Weather Station/City	$T_{oc}$				
	62 °F	67 °F	72 °F	77 °F	82 °F
1 - Rockford AP / Rockford	72.9	76.0	79.2	82.5	85.5
2 - Chicago O'Hare AP / Chicago	72.9	76.0	79.4	82.8	85.5
3 - Springfield #2 / Springfield	73.7	76.7	79.9	83.4	86.4
4 - Belleville SIU RSCH / Belleville	74.9	77.7	81.0	84.3	86.9
5 - Carbondale Southern IL AP / Marion	75.1	77.7	80.9	84.7	87.4

459.7 = conversion factor from °F to °R

= calculation requires absolute temperature for values not calculated as a difference of temperatures.

<sup>1870</sup> ASHRAE, "Ventilation and Infiltration," in 2013 ASHRAE Handbook – Fundamentals (2013): p 16.13

<sup>1871</sup> Estimated 16.8 square feet of gap area. The leakage area is comprised of gaps on top, bottom and on the sides of the dock door. Common dock door dimensions are 8'0" in width with 8 ft, 9 ft or 10 ft heights. The maximum trailer size limits are 8'6" wide x 13'6" high (varies by state). Most trucks require a dock height of between 46 and 52 in. For the purposes of this calculation a 48" dock height and 9'0" wide x 10'0" high door was use, to cover the full range of truck types.

<sup>1872</sup> ASHRAE, "Ventilation and Infiltration," in 2013 ASHRAE Handbook – Fundamentals (2013): p 16.13.

<sup>1873</sup> Based on binned data from TMY3 & adjusted bracketed thermostat setpoint temperatures. Interpolate other values as needed.



**SUMMER COINCIDENT PEAK DEMAND SAVINGS**

$$\Delta kW = (\Delta kWh_{cooling} / (CD * 24)) * CF$$

Where:

$$CF_{SSP} = \text{Summer System Peak Coincidence Factor for Commercial cooling (during system peak hour)}$$

$$= 91.3\%^{1874}$$

$$CF_{PJM} = \text{PJM Summer Peak Coincidence Factor for Commercial cooling (average during peak period)}$$

$$= 47.8\%^{1875}$$

**NATURAL GAS SAVINGS**

Natural Gas savings associated with reduced infiltration through the gaps between the truck and the dock door during the heating season are calculated with the following formula:

$$\Delta \text{therms} = Q_{bs} * t_{open} * HD / \eta$$

Where:

$$Q_{bs} = \text{rate of sensible heat transfer through the gaps before dock door seal or shelter (therm/hr)}$$

$$t_{open} = \text{average hours per day the door is open (hr/day)}$$

$$= 8.25^{1876} \text{ hours or actual.}$$

$$HD = \text{heating days per year, as defined above}$$

$$\eta = \text{efficiency of heating equipment}$$

$$= \text{Actual. If unknown, assume 0.8}$$

**Heat Transfer Through Dock Door without Dock Door Seals or Shelters (Heating Season)**

$$Q_{bs} = (1.08 \text{ Btu}/(\text{hr} * ^\circ\text{F} * \text{cfm})) * CFM_{tot} * (T_{ih} - T_{oh}) / (100,000 \text{ Btu/therm})$$

Where:

$$1.08 = \text{sensible heat transfer coefficient (specific heat of air and unit conversions)}$$

$$CFM_{tot} = \text{Total air flow through gaps (cfm)}$$

$$T_{ih} = \text{Average indoor air temperature during heating season}$$

$$= \text{User input, can assume indoor heating temperature set-point}$$

$$T_{oh} = \text{Average outdoor temp during heating season (}^\circ\text{F)}$$

$$= \text{use table below, based on binned data from TMY3 \& balance point temperature:}$$

Climate Zone -Weather Station/City	Avg Outdoor Air Temp - Heating Season				
	45°F	50°F	55°F	60°F	65°F
1 - Rockford AP / Rockford	26.3	28.8	31.6	34.2	37.3
2 - Chicago O'Hare AP / Chicago	29.4	31.2	34.0	36.8	40.3

<sup>1874</sup> Based on analysis of Itron eShape data for Missouri, calibrated to Illinois loads, supplied by Ameren. The AC load during the utility's peak hour is divided by the maximum AC load during the year.

<sup>1875</sup> Based on analysis of Itron eShape data for Missouri, calibrated to Illinois loads, supplied by Ameren. The average AC load over the PJM peak period (1-5pm, M-F, June through August) is divided by the maximum AC load during the year

<sup>1876</sup> Average loading time estimated at 45 minutes including truck arrival and departure time from: <https://www.novalocks.com/wp-content/uploads/Dock-Planning-Standards-Guide.pdf>. Average time between truck departure and arrival estimated at 90 minutes taken from customer interviews.

Climate Zone -Weather Station/City	Avg Outdoor Air Temp - Heating Season				
	45°F	50°F	55°F	60°F	65°F
3 - Springfield #2 / Springfield	29.4	31.5	34.6	37.7	41.6
4 - Belleville SIU RSCH / Belleville	31.7	33.6	36.2	39.2	42.3
5 - Carbondale Southern IL AP / Marion	32.5	34.9	37.8	40.7	44.0

The total airflow through the gaps, CFM<sub>tot</sub>, includes both infiltration due to wind as well as thermal forces, as follows:

$$CFM_{tot} = \text{sqrt}[(CFM_w)^2 + (CFM_t)^2]$$

Where:

CFM<sub>w</sub> = Infiltration due to the wind (cfm)

CFM<sub>t</sub> = Infiltration due to thermal forces (cfm)

The infiltration due to the wind is calculated as follows:

$$CFM_w = (v_{wh} * C_{wh}) * C_v * L_a * (88 \text{ fpm/mph})$$

Where:

v<sub>wh</sub> = average wind speed during the heating season (mph)

= similar to cooling season wind speed assumptions, use the following table to determine average wind speed based on entryway orientation:

Climate Zone -Weather Station/ City	Entryway Orientation				
	N	E	S	W	Average (unknown)
1 - Rockford AP / Rockford	5.0	4.6	4.9	5.6	5.0
2 - Chicago O'Hare AP / Chicago	5.5	5.2	4.9	5.1	5.2
3 - Springfield #2 / Springfield	5.0	4.9	5.3	5.1	5.1
4 - Belleville SIU RSCH / Belleville	4.3	3.4	3.5	5.3	4.1
5 - Carbondale Southern IL AP / Marion	4.6	3.2	4.2	4.4	4.1

C<sub>wh</sub> = wind speed correction factor due to wind direction in heating season, (%)

= because wind direction is not constant, a wind speed correction factor is used to adjust for the amount of time during the heating season prevailing winds can be expected to impact the entryway. Use the following table to determine the correct wind speed correction factor for the heating applications.

Climate Zone -Weather Station/ City	Entryway Orientation				
	N	E	S	W	Average (unknown)
1 - Rockford AP / Rockford	0.18	0.13	0.30	0.31	0.23
2 - Chicago O'Hare AP / Chicago	0.21	0.10	0.26	0.39	0.24
3 - Springfield #2 / Springfield	0.21	0.14	0.27	0.34	0.24
4 - Belleville SIU RSCH / Belleville	0.31	0.15	0.22	0.29	0.24
5 - Carbondale Southern IL AP / Marion	0.31	0.11	0.27	0.18	0.22

Note that correction factors do not add up to 1 (100%). This is attributed to periods of calm winds.

C<sub>v</sub> = effectiveness of openings,

= 0.3, assumes diagonal wind<sup>1877</sup>

$L_a$  = Leakage Area (gap) between doorway and truck (ft<sup>2</sup>)  
 = 16.8 feet<sup>1878</sup> or Actual.

The infiltration due to thermal forces is calculated as follows:

$$CFM_t = L_a * C_{dh} * (60 \text{ sec/min}) * \text{sqrt}[2 * g * H/2 * (T_{ih} - T_{oh}) / (459.7 + T_{ih})]$$

Where:

$C_{dh}$  = the discharge coefficient during the heating season  
 =  $0.4 + 0.0025 * |T_{ih} - T_{oh}|$   
 = 0.49, Illinois average at indoor air temp of 72°F

Note, values for  $C_{dh}$  show little variation due to balance point temperature, indoor air temperature, and climate zone. As such, if estimating results, the Illinois average value may be used as a simplification.

$g$  = acceleration due to gravity  
 = 32.2 ft/sec<sup>2</sup>

$H$  = dock door height (ft)  
 = user defined

#### **WATER AND OTHER NON-ENERGY IMPACT DESCRIPTIONS AND CALCULATION**

N/A

#### **DEEMED O&M COST ADJUSTMENT CALCULATION**

N/A

**MEASURE CODE: CI-MSC-DDSS-V01-230101**

**REVIEW DEADLINE: 1/1/2026**

---

<sup>1877</sup> ASHRAE, "Ventilation and Infiltration," in 2013 ASHRAE Handbook – Fundamentals (2013): p 16.13

<sup>1878</sup> Estimated 16.8 square feet of gap area. The leakage area is comprised of gaps on top, bottom and on the sides of the dock door. Common dock door dimensions are 8'0" in width with 8 ft, 9 ft or 10 ft heights. The maximum trailer size limits are 8'6" wide x 13'6" high (varies by state). Most trucks require a dock height of between 46 and 52 in. For the purposes of this calculation a 48" dock height and 9'0" wide x 10'0" high door was use, to cover the full range of truck types.

## 4.8.30 Commercial Wall Insulation

### DESCRIPTION

Wall insulation is added to building wall cavities or to building internal/external wall surfaces; foundation insulation is added to building internal/external foundation surfaces, both above grade and below grade. This measure requires pre- and post-implementation R-values and measurements surface areas.

This measure was developed to be applicable to the following program types: RF.

If applied to other program types, the measure savings should be verified.

### DEFINITION OF EFFICIENT EQUIPMENT

The efficient scenario is the installation of added insulation. This measure requires a member of the implementation staff or a participating contractor to evaluate the pre- and post-implementation R-values and to measure surface areas. The requirements for participation in the program will be defined by the utilities.

### DEFINITION OF BASELINE EQUIPMENT

The existing condition will be evaluated by implementation staff or a participating contractor and is likely to be empty or minimally insulated wall cavities, and uninsulated above and below grade foundation walls.

### DEEMED LIFETIME OF EFFICIENT EQUIPMENT

The expected measure life is assumed to be 25 years.<sup>1879</sup>

### DEEMED MEASURE COST

The actual installed cost for this measure should be used in screening.

### LOADSHAPE

Loadshape C01 – Commercial Electric Cooling

Loadshape C03 – Commercial Cooling

Loadshape C04 – Commercial Electric Heating

Loadshape C05 – Commercial Electric Heating and Cooling

### COINCIDENCE FACTOR

The summer peak coincidence factor for cooling is provided in two different ways below. The first is used to estimate peak savings during the utility peak hour and is most indicative of actual peak benefits, and the second represents the *average* savings over the defined summer peak period, and is presented so that savings can be bid into PJM's capacity market. Both values provided are based on analysis of Itron eShape data for Missouri, calibrated to Illinois loads, supplied by Ameren.

$CF_{SSP}$  = Summer System Peak Coincidence Factor for Commercial cooling (during system peak hour)  
 = 91.3%<sup>1880</sup>

$CF_{PJM}$  = PJM Summer Peak Coincidence Factor for Commercial cooling (average during peak period)

---

<sup>1879</sup> Navigant 'ComEd Effective Useful Life Research Report', May 2018.

<sup>1880</sup> Based on analysis of Itron eShape data for Missouri, calibrated to Illinois loads, supplied by Ameren. The AC load during the utility's peak hour is divided by the maximum AC load during the year.

$$= 47.8\%^{1881}$$

---



---

**Algorithm**

---



---

**CALCULATION OF SAVINGS**

**ELECTRIC ENERGY SAVINGS**

Where available, savings from wall and foundation insulation measures should be determined through a custom analysis. When that is not feasible for the program the following engineering algorithms can be used.

$$\Delta kWh = \Delta kWh_{cooling} + \Delta kWh_{heatingElectric} + \Delta kWh_{heatingGas}$$

Where:

$$\begin{aligned} \Delta kWh_{cooling} &= \text{If building is cooled, reduction in annual cooling requirement due to wall insulation} \\ &= [ (1 / R_{ExistWall} - 1 / R_{NewWall}) * A_{wall} + (1 / R_{ExistAG} - 1 / R_{NewAG}) * A_{AG} + (1 / R_{ExistBG} - 1 / R_{NewBG}) * A_{BG} ] * CDD55 * 24 / 1000 / \eta_{Cool} * \%Cool \end{aligned}$$

Where:

**R<sub>NewWall</sub>** = R-value of proposed new wall assembly (including all layers between inside air and outside air).

= Actual

**R<sub>ExistWall</sub>** = R-value value of existing assembly and any existing insulation.

= Minimum of R-5 for uninsulated assemblies<sup>1882</sup>

**A<sub>wall</sub>** = Net area of insulated wall (ft<sup>2</sup>)

= Actual

**R<sub>NewAG</sub>** = Effective R-value of proposed new Above-Ground Foundation assembly (including all layers between inside air and outside air).

= Actual

**R<sub>ExistAG</sub>** = Effective R-value value of existing Above-Ground Foundation assembly and any existing insulation.

= Minimum of R-5 for uninsulated assemblies<sup>1883</sup>

**A<sub>AG</sub>** = Net area of Above-Ground Foundation being insulated (ft<sup>2</sup>)

= Actual

**R<sub>NewBG</sub>** = Effective R-value of proposed new Foundation Below Grade assembly (including all layers between inside air and outside ground).

= Actual

**R<sub>ExistBG</sub>** = Effective R-value value of existing Foundation Below Grade assembly and any existing insulation.

---

<sup>1881</sup> Based on analysis of Itron eShape data for Missouri, calibrated to Illinois loads, supplied by Ameren. The average AC load over the PJM peak period (1-5pm, M-F, June through August) is divided by the maximum AC load during the year.

<sup>1882</sup> An estimate based on review of Madison Gas and Electric, Exterior Wall Insulation, R-value for no insulation in walls, and NREL's Building Energy Simulation Test for Existing Homes (BESTEST-EX).

<sup>1883</sup> An estimate based on review of Madison Gas and Electric, Exterior Wall Insulation, R-value for no insulation in walls, and NREL's Building Energy Simulation Test for Existing Homes (BESTEST-EX).

NOTE: Added to the above R-values of Below Grade assemblies shall be the following deemed Average Earth R-values, which account for transmission of heat through direct contact with the earth outside the foundation. The Effective Ground Contact R-value varies as a function of the average depth below grade of the bottom of the foundation:<sup>1884</sup>

Depth Below Grade of Bottom of Foundation	Earth R-value	Average Earth R-value
0 feet	2.44 F-Ft <sup>2</sup> -Hr/Btu	2.44 F-Ft <sup>2</sup> -Hr/Btu
1 feet	4.50 F-Ft <sup>2</sup> -Hr/Btu	3.47 F-Ft <sup>2</sup> -Hr/Btu
2 feet	6.30 F-Ft <sup>2</sup> -Hr/Btu	4.41 F-Ft <sup>2</sup> -Hr/Btu
3 feet	8.40 F-Ft <sup>2</sup> -Hr/Btu	5.41 F-Ft <sup>2</sup> -Hr/Btu
4 feet	10.44 F-Ft <sup>2</sup> -Hr/Btu	6.42 F-Ft <sup>2</sup> -Hr/Btu
5 feet	12.66 F-Ft <sup>2</sup> -Hr/Btu	7.46 F-Ft <sup>2</sup> -Hr/Btu
6 feet	14.49 F-Ft <sup>2</sup> -Hr/Btu	8.46 F-Ft <sup>2</sup> -Hr/Btu
7 feet	17.00 F-Ft <sup>2</sup> -Hr/Btu	9.53 F-Ft <sup>2</sup> -Hr/Btu
8 feet	20.00 F-Ft <sup>2</sup> -Hr/Btu	10.69 F-Ft <sup>2</sup> -Hr/Btu

A\_BG = Net area of Foundation Below Grade being insulated (ft<sup>2</sup>)  
 = Actual

CDD55/yr = Annual cooling degree days at 55 °F base for the climate zone of the location of the building as deemed in the table below<sup>1885</sup>

Climate Zone	Cooling Degree Days: CDD55/yr
1 (Rockford)	2284
2 (Chicago)	2494
3 (Springfield)	2761
4 (Belleville)	3480
5 (Marion/Murphysboro)	3186

24 = Converts days to hours

1000 = Converts Btu to kBtu

ηCool = Efficiency of cooling system. Actual, if known. Alternatively, use IECC 2012 as a default source if equipment type is known, or as deemed from table below<sup>1886</sup>

Space Cooling / Heating Source	Deemed Cooling EER	Deemed Cooling SEER
No Cooling	N/A	N/A
Unknown Cooling Source	11	13

<sup>1884</sup> Source: Illinois Statewide Technical Reference Manual V10.0, Volume 3 - Section 5.6.2 Basement Sidewall Insulation, Table on page 338 of 401.

<sup>1885</sup> National Centers for Environmental Information (NCEI) Annual Normals, from 2006 - 2020, calculated with a base temp of 55°F.

<sup>1886</sup> Simplified version of IECC 2012 as a conservative estimate of what is existing

%Cool = Percent of building ***where wall or foundation insulation is to be installed*** that is cooled  
 = Actual %, if known, or, If actual % unknown, use following deemed values:

Is Space Being Insulated Cooled?	Deemed %Cool, if actual % is unknown
Yes	100%
No	0%

**For example**, for a commercial building with unknown cooling equipment in Rockford with increase in wall insulation: R\_ExistWall = 5.0; R\_NewWall = 16.0; A\_wall = 1500; CDD55 = 2284; ηCool = 13.0; %Cool = 100%  

$$\Delta kWh_{cooling} = (1 / 5.0 - 1 / 16.0) * 1500 * 2284 * 24 / 1000 / 11.0 * 100\%$$

$$= 1028 \text{ kWh}$$

ΔkWh\_heatingElectric = If electric heat (resistance or heat pump), reduction in annual electric heating due to wall and/or foundation insulation

$$= [ (1 / R_{ExistWall} - 1 / R_{NewWall}) * A_{wall} + (1 / R_{ExistAG} - 1 / R_{NewAG}) * A_{AG} + (1 / R_{ExistBG} - 1 / R_{NewBG}) * A_{BG} ] * HDD55 * 24 / \eta_{Heat} / 3412 * \%ElectricHeat$$

Where:

HDD55 = Annual heating degree days at 55 °F base for the climate zone of the building, as deemed in the table below <sup>1887</sup>

Climate Zone	Heating Degree Days: HDD55/yr
1 (Rockford)	4171
2 (Chicago)	3760
3 (Springfield)	3296
4 (Belleville)	2351
5 (Marion/Murphysboro)	2499

ηHeat = Efficiency of heating system. Actual, or as deemed from table below

System Type	Cooling Capacity of Equipment	Age of Equipment	HSPF Estimate	η (Effective COP Estimate) (HSPF/3.413)
<b>Heat Pump</b> <sup>1888</sup>	All	Before 2009	6.8	2.0
	< 65,000 Btu/h	2009 - 2017	7.7	2.3
		2017 on	8.2	2.40

<sup>1887</sup> National Centers for Environmental Information (NCEI) Annual Normals, from 2006 - 2020, calculated with a base temp of 55°F

<sup>1888</sup> Minimum heating efficiency standards for heat pumps are sourced from the Code of Federal Standards for Small and Large Commercial Package Air Conditioning and Heating Equipment (Air Cooled), 10 CFR 431.97 with compliance dates of June 16, 2008; January 1, 2010; January 1, 2017; and January 1, 2018. As the first federal appliance standards for heating efficiency for commercial heat pumps went into effect in June 2008, assuming efficiency standards equivalent to residential heat pumps prior to that date.

System Type	Cooling Capacity of Equipment	Age of Equipment	HSPF Estimate	$\eta$ (Effective COP Estimate) (HSPF/3.413)
	$\geq 65,000$ Btu/h and $< 135,000$ Btu/h	2010 on	11.3	3.3
	$\geq 135,000$ Btu/h and $< 240,000$ Btu/h	2010 on	10.9	3.2
	$\geq 240,000$ Btu/h and $< 760,000$ Btu/h	2010 on	10.9	3.2
<b>Resistance</b>	N/A	N/A	N/A	1
<b>Natural Gas Furnace or Boiler</b>	N/A	N/A	N/A	$0.8 E_T$

3412 = Converts Btu to kWh

%ElectricHeat = Percent of building ***where wall or foundation insulation is to be installed*** that is electrically heated

= Actual %, if known, or, If actual % unknown, use following deemed values:

Is Space Being Insulated Electrically Heated?	Deemed %ElectricHeat, if actual % is unknown
Yes	100%
No	0%

**For example**, for a commercial building with resistance heating in Rockford:  $R_{ExistWall} = 5.0$ ;  $R_{NewWall} = 16.0$ ;  $A_{wall} = 1500$ ;  $HDD55 = 4171$ ;  $\eta_{Heat} = 1.0$ ; %ElectricHeat = 100%

$$\Delta kWh_{heatingElec} = (1 / 5.0 - 1 / 16.0) * 1500 * 4171 * 24 / 3412 / 1.0 * 100\% = 6051 \text{ kWh}$$

$\Delta kWh_{heatingGas}$  = If gas *furnace* heat, kWh savings for reduction in combustion fan run time  
 =  $\Delta Therms * F_e * 29.3$

Where:

$\Delta Therms$  = Annual therms of gas space heating saved, as determined below

$F_e$  = Furnace or boiler combustion fan energy consumption as a percentage of annual fuel consumption  
 = 7.7%<sup>1889</sup>

29.3 = conversion of therms to kWh (= 100000 / 3412 )

<sup>1889</sup>  $F_e$  is not one of the AHRI certified ratings provided for residential furnaces, but can be reasonably estimated from a calculation based on the certified values for fuel energy ( $E_f$  in MMBtu/yr) and  $E_{ae}$  (kWh/yr). An average of a 300 record sample (non-random) out of 1495 was 3.14%. This is, appropriately, ~50% greater than the ENERGY STAR version 3 criteria for 2%  $F_e$ . See "Programmable Thermostats Furnace Fan Analysis.xlsx" for reference.



**For example**, if:  $\Delta\text{Therms} = 258$ ;  $F_e = 7.7\%$ , then:

$$\begin{aligned} \Delta\text{kWh}_{\text{heatingGas}} &= 258 * 7.7\% * 29.3 \\ &= 582 \text{ kWh} \end{aligned}$$

**For example**, based on the above calculations for electric resistance, total annual kWh savings =

$$\begin{aligned} \text{Total Annual kWh Savings} &= 1028 + 6051 + 0 \\ &= 7079 \text{ kWh} \end{aligned}$$

**SUMMER COINCIDENT PEAK DEMAND SAVINGS**

$$\Delta\text{kW} = \Delta\text{kWh}_{\text{cooling}} / \text{EFLH}_{\text{Cooling}} * \text{CF}$$

Where:

$\Delta\text{kWh}_{\text{cooling}}$  = Annual kWh saving in cooling energy use, as determined above

$\text{EFLH}_{\text{cooling}}$  = Equivalent Full Load Hours for cooling in Existing Buildings are provided in section 4.4 HVAC End Use

$\text{CF}_{\text{SSP}}$  = Summer System Peak Coincidence Factor for Commercial cooling (during system peak hour)  
= 91.3%<sup>1890</sup>

$\text{CF}_{\text{PJM}}$  = PJM Summer Peak Coincidence Factor for Commercial cooling (average during peak period)  
= 47.8%<sup>1891</sup>

**For example**, for a Grocery store in Rockford with unknown cooling per above example:  $\Delta\text{kWh}_{\text{cooling}} = 827$ ;  $\text{EFLH}_{\text{Cooling}} = 826$ ;  $\text{CF} = 0.478$ ; then:

$$\begin{aligned} \text{Summer Coincident Peak savings} &= 827 / 826 * 0.478 \\ &= 0.48 \text{ kW} \end{aligned}$$

**NATURAL GAS SAVINGS**

If Natural Gas heating:

$$\Delta\text{Therms} = [ (1 / R_{\text{ExistWall}} - 1 / R_{\text{NewWall}}) * A_{\text{wall}} + (1 / R_{\text{ExistAG}} - 1 / R_{\text{NewAG}}) * A_{\text{AG}} + (1 / R_{\text{ExistBG}} - 1 / R_{\text{NewBG}}) * A_{\text{BG}} ] * \text{HDD55} * 24 / \eta_{\text{Heat}} / 100,000 * \% \text{GasHeat}$$

Where:

$\% \text{GasHeat}$  = Percent of space being retrofitted with insulation that is heated using gas  
= Actual %, if known, or, If actual % unknown, use following deemed values:

Is Space Being Insulated Heated with Gas?	Deemed %GasHeat, if actual % is unknown
Yes	100%

<sup>1890</sup> Based on analysis of Itron eShape data for Missouri, calibrated to Illinois loads, supplied by Ameren. The AC load during the utility’s peak hour is divided by the maximum AC load during the year.

<sup>1891</sup> Based on analysis of Itron eShape data for Missouri, calibrated to Illinois loads, supplied by Ameren. The average AC load over the PJM peak period (1-5pm, M-F, June through August) is divided by the maximum AC load during the year.

Is Space Being Insulated Heated with Gas?	Deemed %GasHeat, if actual % is unknown
No	0%

Other variables as defined above.

**For example**, for a commercial building in Rockford with unknown gas heat:  $R_{ExistWall} = 5.0$ ;  $R_{NewWall} = 16.0$ ;  $A_{wall} = 1500$ ;  $HDD55 = 4272$ ;  $\eta_{Heat} = 0.8$ ;  $\%GasHeat = 100\%$ ; then

$$\begin{aligned} \text{Annual Therm Savings} &= (1 / 5.0 - 1 / 16.0) * 1500 * 4272 * 24 / 0.8 / 100000 * 100\% \\ &= 264 \text{ therms} \end{aligned}$$

**WATER IMPACT DESCRIPTIONS AND CALCULATION**

N/A

**DEEMED O&M COST ADJUSTMENT CALCULATION**

N/A

**MEASURE CODE: CI-HVC-WINS-V03-240101**

**REVIEW DEADLINE: 1/1/2026**